

## Advance Information

MPC8240EC  
Rev. 4, 11/2003

MPC8240  
Integrated Processor  
Hardware Specifications



The MPC8240 combines a MPC603e core microprocessor with a PCI bridge. The MPC8240 PCI support allows system designers to rapidly create systems using peripherals already designed for PCI and the other standard interfaces. The MPC8240 also integrates a high-performance memory controller that supports various types of DRAM and ROM. The MPC8240 is the first of a family of products that provide system-level support for industry standard interfaces with PowerPC™ microprocessor cores.

This hardware specification describes pertinent electrical and physical characteristics of the MPC8240. For functional characteristics of the processor, refer to the *MPC8240 Integrated Processor User's Manual* (MPC8240UM).

This hardware specification contains the following topics:

Topic	Page
Section 1.1, "Overview"	1
Section 1.2, "Features"	3
Section 1.3, "General Parameters"	5
Section 1.4, "Electrical and Thermal Characteristics"	5
Section 1.5, "Package Description"	27
Section 1.6, "PLL Configurations"	34
Section 1.7, "System Design Information"	35
Section 1.8, "Document Revision History"	45
Section 1.9, "Ordering Information"	49

To locate any published errata or updates for this document, refer to the website at <http://www.motorola.com/semiconductors>.

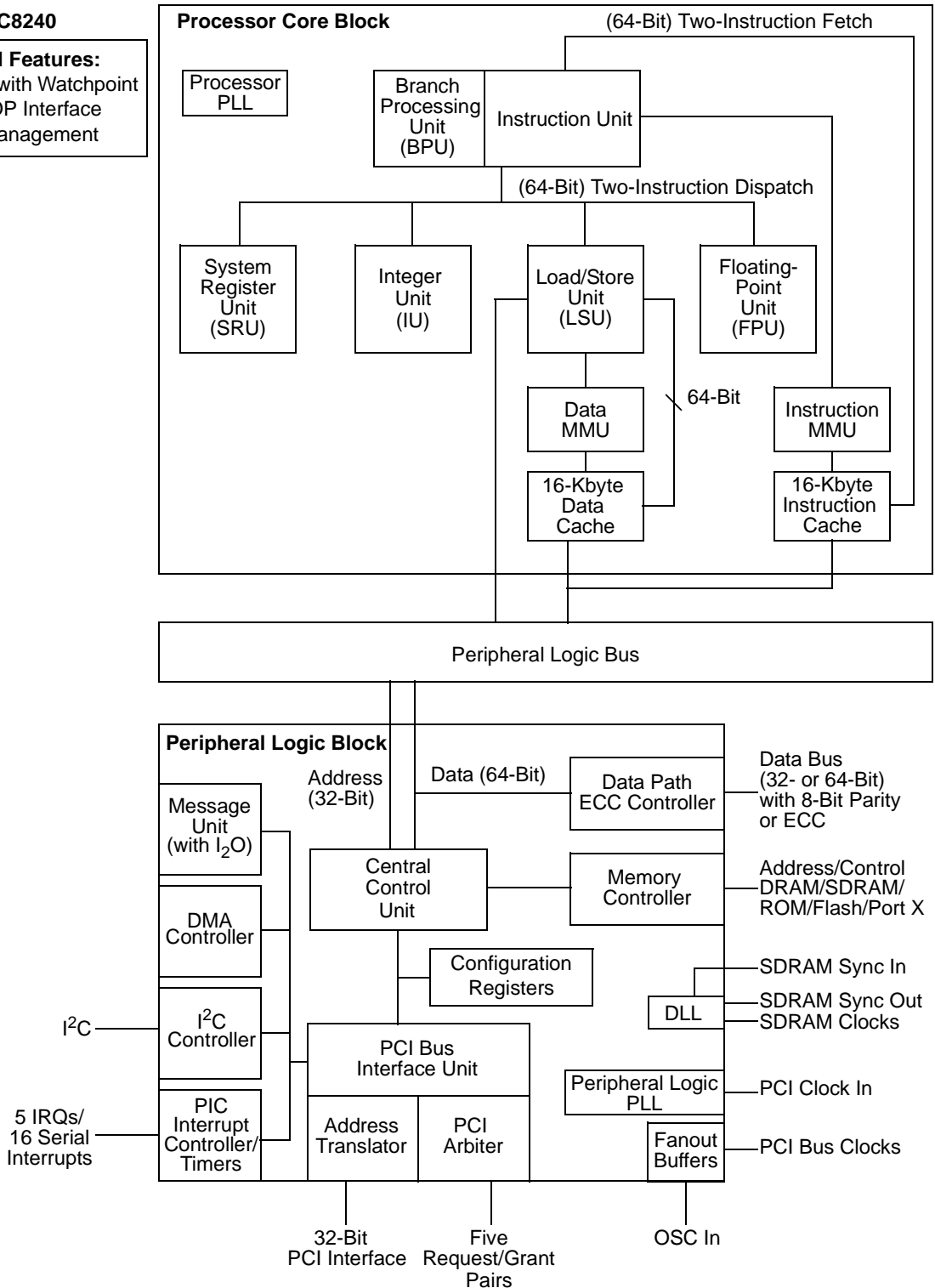
## 1.1 Overview

The MPC8240 integrated processor is comprised of a peripheral logic block and a 32-bit superscalar MPC603e core, as shown in Figure 1.

### MPC8240

#### Additional Features:

- Prog I/O with Watchpoint
- JTAG/COP Interface
- Power Management



**Figure 1. MPC8240 Block Diagram**

The peripheral logic integrates a PCI bridge, memory controller, DMA controller, PIC interrupt controller, I<sub>2</sub>O controller, and an I<sup>2</sup>C controller. The MPC603e core is a full-featured, high-performance processor with floating-point support, memory management, a 16-Kbyte instruction cache, a 16-Kbyte data cache, and

power management features. The integration reduces the overall packaging requirements and the number of discrete devices required for an embedded system.

The MPC8240 contains an internal peripheral logic bus that interfaces the MPC603e core to the peripheral logic. The core can operate at a variety of frequencies, allowing the designer to trade off performance for power consumption. The MPC603e core is clocked from a separate PLL, which is referenced to the peripheral logic PLL. This allows the microprocessor and the peripheral logic block to operate at different frequencies while maintaining a synchronous bus interface. The interface uses a 64- or 32-bit data bus (depending on memory data bus width) and a 32-bit address bus along with control signals that enable the interface between the processor and peripheral logic to be optimized for performance. PCI accesses to the MPC8240 memory space are passed to the processor bus for snooping purposes when snoop mode is enabled.

The MPC8240 features serve a variety of embedded applications. In this way, the MPC603e core and peripheral logic remain general-purpose. The MPC8240 can be used as either a PCI host or an agent controller.

## 1.2 Features

This section summarizes features of the MPC8240. Major features of the MPC8240 are as follows:

- Peripheral logic
  - Memory interface
    - Programmable timing supporting either FPM DRAM, EDO DRAM, or SDRAM
    - High-bandwidth bus (32- or 64-bit data bus) to DRAM
    - Supports one to eight banks of 4-, 16-, 64-, or 128-Mbit memory devices
    - Supports 1-Mbyte to 1-Gbyte DRAM memory
    - 16 Mbytes of ROM space
    - 8-, 32-, or 64-bit ROM
    - Write buffering for PCI and processor accesses
    - Supports normal parity, read-modify-write (RMW), or ECC
    - Data-path buffering between memory interface and processor
    - Low-voltage TTL logic (LVTTL) interfaces
    - Port X: 8-, 32-, or 64-bit general-purpose I/O port using ROM controller interface with programmable address strobe timing
  - 32-bit PCI interface operating up to 66 MHz
    - PCI 2.1-compliant
    - PCI 5.0-V tolerance
    - Support for PCI locked accesses to memory
    - Support for accesses to PCI memory, I/O, and configuration spaces
    - Selectable big- or little-endian operation
    - Store gathering of processor-to-PCI write and PCI-to-memory write accesses
    - Memory prefetching of PCI read accesses
    - Selectable hardware-enforced coherency
    - PCI bus arbitration unit (five request/grant pairs)
    - PCI agent mode capability

## Features

- Address translation unit
- Some internal configuration registers accessible from PCI
- Two-channel integrated DMA controller (writes to ROM/Port X not supported)
  - Supports direct mode or chaining mode (automatic linking of DMA transfers)
  - Supports scatter gathering—Read or write discontinuous memory
  - Interrupt on completed segment, chain, and error
  - Local-to-local memory
  - PCI-to-PCI memory
  - PCI-to-local memory
  - PCI memory-to-local memory
- Message unit
  - Two doorbell registers
  - Two inbound and two outbound messaging registers
  - I<sup>2</sup>O message controller
- I<sup>2</sup>C controller with full master/slave support (except broadcast all)
- Programmable interrupt controller (PIC)
  - Five hardware interrupts (IRQs) or 16 serial interrupts
  - Four programmable timers
- Integrated PCI bus, CPU, and SDRAM clock generation
- Programmable PCI bus, 60x, and memory interface output drivers
- Dynamic power management—Supports 60x nap, doze, and sleep modes
- Programmable input and output signals with watchpoint capability
- Built-in PCI bus performance monitor facility
  - Debug features
    - Memory attribute and PCI attribute signals
    - Debug address signals
    - $\overline{\text{MIV}}$  signal—Marks valid address and data bus cycles on the memory bus
    - Error injection/capture on data path
    - IEEE 1149.1 (JTAG)/test interface
- Processor core interface
  - High-performance, superscalar processor core
  - Integer unit (IU), floating-point unit (FPU) (software enabled or disabled), load/store unit (LSU), system register unit (SRU), and a branch processing unit (BPU)
  - 16-Kbyte instruction cache
  - 16-Kbyte data cache
  - Lockable L1 cache, entire cache or on a per-way basis

## 1.3 General Parameters

The following list provides a summary of the general parameters of the MPC8240:

Technology	0.29- $\mu$ m CMOS, five-layer metal
Die size	73 mm <sup>2</sup>
Transistor count	3.1 million
Logic design	Fully-static
Packages	Surface mount 352 tape ball grid array (TBGA)
Core power supply	2.5 V $\pm$ 5% V DC (nominal; see Table 2 for recommended operating conditions)
I/O power supply	3.0- to 3.6-V DC

## 1.4 Electrical and Thermal Characteristics

This section provides the AC and DC electrical specifications and thermal characteristics for the MPC8240.

### 1.4.1 DC Electrical Characteristics

The following sections describe the MPC8240 absolute maximum ratings, recommended operating conditions, DC electrical specifications, output driver characteristics, and power data characteristics.

#### 1.4.1.1 Absolute Maximum Ratings

The tables in this section describe the MPC8240 DC electrical characteristics. Table 1 provides the absolute maximum ratings.

**Table 1. Absolute Maximum Ratings**

Characteristic <sup>1</sup>	Symbol	Range	Unit
Supply voltage—CPU core and peripheral logic	V <sub>DD</sub>	-0.3 to 2.75	V
Supply voltage—memory bus drivers	GV <sub>DD</sub>	-0.3 to 3.6	V
Supply voltage—PCI and standard I/O buffers	OV <sub>DD</sub>	-0.3 to 3.6	V
Supply voltage—PLLs and DLL	AV <sub>DD</sub> /AV <sub>DD</sub> 2/LAV <sub>DD</sub>	-0.3 to 2.75	V
Supply voltage—PCI reference	LVD <sub>DD</sub>	-0.3 to 5.4	V
Input voltage <sup>2</sup>	V <sub>in</sub>	-0.3 to 3.6	V
Operational die-junction temperature range	T <sub>j</sub>	0 to 105	°C
Storage temperature range	T <sub>stg</sub>	-55 to 150	°C

**Notes:**

1. Functional and tested operating conditions are given in Table 2. Absolute maximum ratings are stress ratings only, and functional operation at the maximums is not guaranteed. Stresses beyond those listed may affect device reliability or cause permanent damage to the device.
2. PCI inputs with LV<sub>DD</sub> = 5 V  $\pm$  5% V DC may be correspondingly stressed at voltages exceeding LV<sub>DD</sub> + 0.5 V DC.

## 1.4.1.2 Recommended Operating Conditions

Table 2 provides the recommended operating conditions for the MPC8240.

**Table 2. Recommended Operating Conditions <sup>1</sup>**

Characteristic		Symbol	Recommended Value	Unit	Notes
Supply voltage		$V_{DD}$	$2.5 \pm 5\%$	V	4, 6
Supply voltage for PCI and standard bus standards		$OV_{DD}$	$3.3 \pm 0.3$	V	6
Supply voltages for memory bus drivers		$GV_{DD}$	$3.3 \pm 5\%$	V	8
PLL supply voltage—CPU core logic		$AV_{DD}$	$2.5 \pm 5\%$	V	4, 6
PLL supply voltage—peripheral logic		$AV_{DD2}$	$2.5 \pm 5\%$	V	4, 7
DLL supply voltage		$LAV_{DD}$	$2.5 \pm 5\%$	V	4, 7
PCI reference		$LV_{DD}$	$5.0 \pm 5\%$	V	9, 10
			$3.3 \pm 0.3$	V	9, 10
Input voltage	$LV_{DD}$ input-tolerant signals	$V_{in}$	0 to 3.6 or 5.75	V	2, 3
	All other inputs		0 to 3.6	V	5
Die-junction temperature		$T_j$	0 to 105	°C	

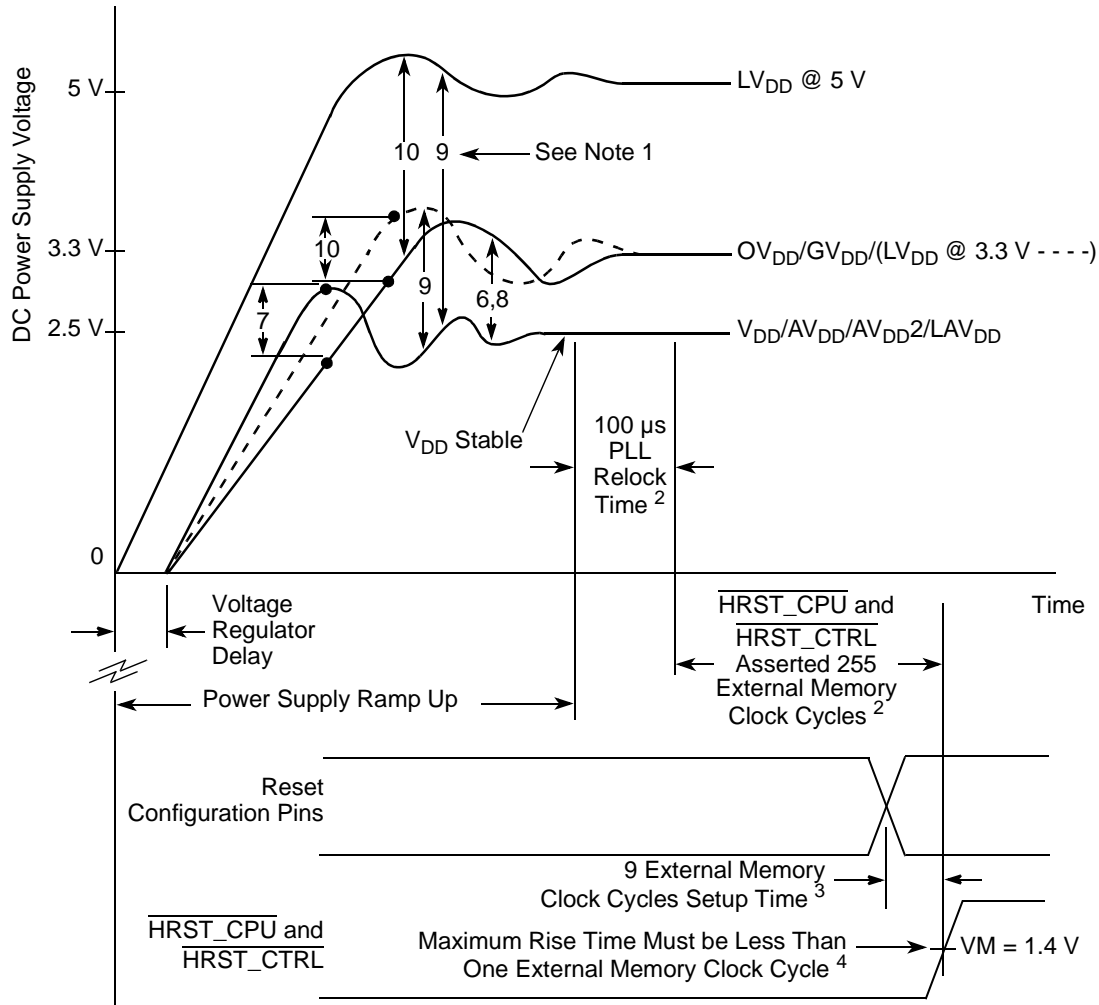
**Notes:**

- These are the recommended and tested operating conditions. Proper device operation outside of these conditions is not guaranteed.
- These signals are designed to withstand  $LV_{DD} + 0.5$  V DC when  $LV_{DD}$  is connected to a 3.3- or 5.0-V DC power supply.
- $LV_{DD}$  input tolerant signals: PCI interface, PIC control, and OSC\_IN signals.
- See Section 1.9, "Ordering Information," for details on a modified voltage ( $V_{DD}$ ) version device.

**Cautions:**

- Input voltage ( $V_{in}$ ) must not be greater than the supply voltage ( $V_{DD}/AV_{DD}/AV_{DD2}/LAV_{DD}$ ) by more than 2.5 V at all times, including during power-on reset.
- $OV_{DD}$  must not exceed  $V_{DD}/AV_{DD}/AV_{DD2}/LAV_{DD}$  by more than 1.8 V at any time, including during power-on reset. This limit may be exceeded for a maximum of 20 ms during power-on reset and power-down sequences.
- $V_{DD}/AV_{DD}/AV_{DD2}/LAV_{DD}$  must not exceed  $OV_{DD}$  by more than 0.6 V at any time, including during power-on reset. This limit may be exceeded for a maximum of 20 ms during power-on reset and power-down sequences.
- $GV_{DD}$  must not exceed  $V_{DD}/AV_{DD}/AV_{DD2}/LAV_{DD}$  by more than 1.8 V at any time, including during power-on reset. This limit may be exceeded for a maximum of 20 ms during power-on reset and power-down sequences.
- $LV_{DD}$  must not exceed  $V_{DD}/AV_{DD}/AV_{DD2}/LAV_{DD}$  by more than 5.4 V at any time, including during power-on reset. This limit may be exceeded for a maximum of 20 ms during power-on reset and power-down sequences.
- $LV_{DD}$  must not exceed  $OV_{DD}$  by more than 3.6 V at any time, including during power-on reset. This limit may be exceeded for a maximum of 20 ms during power-on reset and power-down sequences.

Figure 2 shows the supply voltage sequencing and separation cautions.

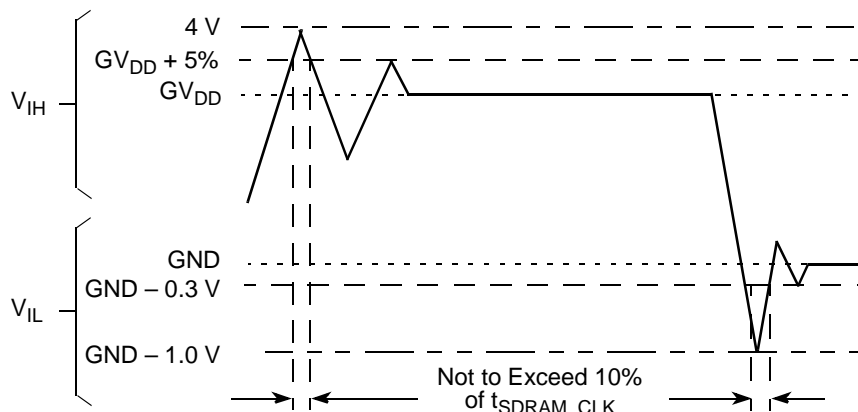


**Notes:**

1. Numbers associated with waveform separations correspond to caution numbers listed in Table 2.
2. Refer to Table 7 for additional information on PLL relock and reset signal assertion timing requirements.
3. Refer to Table 8 for additional information on reset configuration pin setup timing requirements.
4. For the device to be in the non-reset state, HRST\_CPU/HRST\_CTRL must transition from a logic 0 to a

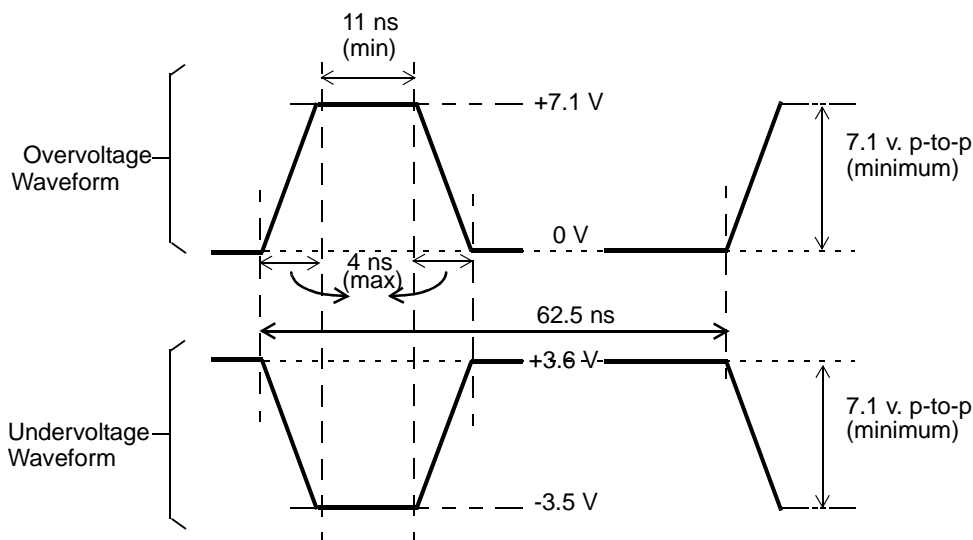
**Figure 2. Supply Voltage Sequencing and Separation Cautions**

Figure 3 shows the overshoot and undershoot voltage of the memory interface of the MPC8240.



**Figure 3. Overshoot/Undershoot Voltage**

Figure 4 and Figure 5 show the overshoot and undershoot voltage of the PCI interface of the MPC8240 for the 3.3-volt and 5-volt signals, respectively.



**Figure 4. Maximum AC Waveforms for 3.3-V Signaling**



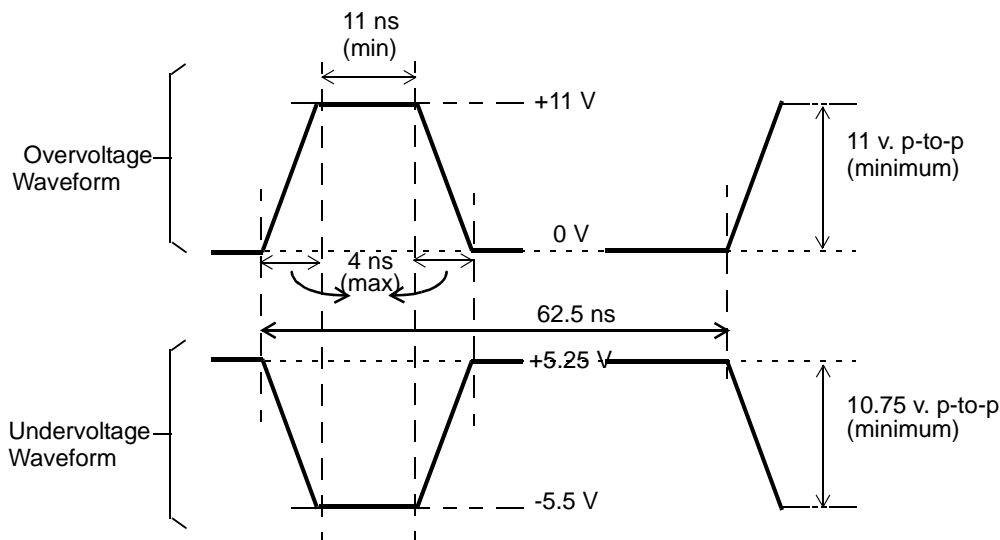


Figure 5. Maximum AC Waveforms for 5-V Signaling

### 1.4.1.3 DC Electrical Specifications

Table 3 provides the DC electrical characteristics for the MPC8240.

Table 3. DC Electrical Specifications

At recommended operating conditions (see Table 2)

Characteristic	Condition <sup>3</sup>	Symbol	Min	Max	Unit
Input high voltage <sup>5</sup>	PCI only	$V_{IH}$	$0.65 \times OV_{DD}$	$LV_{DD}$	V
Input low voltage	PCI only	$V_{IL}$	—	$0.3 \times OV_{DD}$	V
Input high voltage	All other pins ( $GV_{DD} = 3.3$ V)	$V_{IH}$	2.0	3.3	V
Input low voltage	All inputs except PCI_SYNC_IN	$V_{IL}$	GND	0.8	V
PCI_SYNC_IN input high voltage		$CV_{IH}$	2.4	—	V
PCI_SYNC_IN input low voltage		$CV_{IL}$	—	0.4	V
Input leakage current <sup>4</sup> for pins using DRV_PCI driver	$0.5 \text{ V} \leq V_{in} \leq 2.7 \text{ V}$ @ $LV_{DD} = 4.75 \text{ V}$	$I_L$	—	$\pm 70$	$\mu\text{A}$
Input leakage current <sup>4</sup> for all others	$LV_{DD} = 3.6 \text{ V}$ $GV_{DD} \leq 3.465 \text{ V}$	$I_L$	—	$\pm 10$	$\mu\text{A}$
Output high voltage	$I_{OH} = \text{driver-dependent}^2$ ( $GV_{DD} = 3.3 \text{ V}$ )	$V_{OH}$	2.4	—	V
Output low voltage	$I_{OL} = \text{driver-dependent}^2$ ( $GV_{DD} = 3.3 \text{ V}$ )	$V_{OL}$	—	0.4	V

**Table 3. DC Electrical Specifications (continued)**

At recommended operating conditions (see Table 2)

Characteristic	Condition <sup>3</sup>	Symbol	Min	Max	Unit
Capacitance	$V_{in} = 0\text{ V}, f = 1\text{ MHz}$	$C_{in}$	—	7.0	pF

**Notes:**

1. See Table 17 for pins with internal pull-up resistors.
2. See Table 4 for the typical drive capability of a specific signal pin based on the type of output driver associated with that pin as listed in Table 17.
3. These specifications are for the default driver strengths indicated in Table 4.
4. Leakage current is measured on input pins and on output pins in the high impedance state. The leakage current is measured for nominal  $OV_{DD}/LV_{DD}$ , and  $V_{DD}$  or both  $OV_{DD}/LV_{DD}$  and  $V_{DD}$  must vary in the same direction.
5. The minimum input high voltage is not compliant with the *PCI Local Bus Specification (Rev 2.1)*, which specifies  $0.5 \times OV_{DD}$  for minimum input high voltage.

### 1.4.1.4 Output Driver Characteristics

Table 4 provides information on the characteristics of the output drivers referenced in Table 17. The values are from the MPC8240 IBIS model (v1.1 IBIS, v1.2 file) and are untested. For additional detailed information, see the complete IBIS model listing at: [http://www.mot.com/SPS/PowerPC/teksupport/tools/IBIS/kahlua\\_1.ibs.txt](http://www.mot.com/SPS/PowerPC/teksupport/tools/IBIS/kahlua_1.ibs.txt)

**Table 4. Drive Capability of MPC8240 Output Pins**

Driver Type	Programmable Output Impedance ( $\Omega$ )	Supply Voltage	$I_{OH}$	$I_{OL}$	Unit	Notes
DRV_STD	20	$OV_{DD} = 3.3\text{ V}$	36.7	30.0	mA	2, 4
	40 (default)	$OV_{DD} = 3.3\text{ V}$	18.7	15.0	mA	2, 4
DRV_PCI	25	$OV_{DD} = 3.3\text{ V}$	11.0	20.6	mA	1, 3
	50 (default)	$OV_{DD} = 3.3\text{ V}$	5.6	10.3	mA	1, 3
DRV_MEM_ADDR DRV_PCI_CLK	8 (default)	$GV_{DD} = 3.3\text{ V}$	89.0	76.3	mA	2, 4
	13.3	$GV_{DD} = 3.3\text{ V}$	55.9	46.4	mA	2, 4
	20	$GV_{DD} = 3.3\text{ V}$	36.7	30.0	mA	2, 4
	40	$GV_{DD} = 3.3\text{ V}$	18.7	15.0	mA	2, 4
DRV_MEM_DATA	20 (default)	$GV_{DD} = 3.3\text{ V}$	36.7	30.0	mA	2, 4
	40	$GV_{DD} = 3.3\text{ V}$	18.7	15.0	mA	2, 4

**Notes:**

1. For DRV\_PCI,  $I_{OH}$  read from the IBIS listing in the pull-up mode, I(Min) column, at the 0.33-V label by interpolating between the 0.3- and 0.4-V table entries' current values that correspond to the PCI  $V_{OH} = 2.97 = 0.9 \times OV_{DD}$  ( $OV_{DD} = 3.3\text{ V}$ ) where table entry voltage =  $OV_{DD} - PCI\ V_{OH}$ .
2. For all others with  $GV_{DD}$  or  $OV_{DD} = 3.3\text{ V}$ ,  $I_{OH}$  read from the IBIS listing in the pull-up mode, I(Min) column, at the 0.9-V table entry that corresponds to the  $V_{OH} = 2.4\text{ V}$  where table entry voltage =  $GV_{DD}/OV_{DD} - V_{OH}$ .
3. For DRV\_PCI,  $I_{OL}$  read from the IBIS listing in the pull-down mode, I(Min) column, at  $0.33\text{ V} = PCI\ V_{OL} = 0.1 \times OV_{DD}$  ( $OV_{DD} = 3.3\text{ V}$ ) by interpolating between the 0.3- and 0.4-V table entries.

### 1.4.1.5 Power Characteristics

Table 5 provides power consumption data for the MPC8240.

**Table 5. Preliminary Power Consumption**

Mode	PCI Bus Clock/Memory Bus Clock CPU Clock Frequency (MHz)				Unit	Notes
	33/66/166	33/66/200	33/100/200	66/100/200		
Typical	2.5	2.8	3.0	3.0	W	1, 5
Maximum—FP	2.9	3.3	3.5	3.5	W	1, 2
Maximum—INT	2.6	2.9	3.2	3.3	W	1, 3
Doze	1.8	1.9	2.1	2.1	W	1, 4, 6
Nap	667	667	858	858	mW	1, 4, 6
Sleep	477	477	477	762	mW	1, 4, 6
I/O Power Supplies						
Mode	Min		Max		Unit	Notes
Typical—OV <sub>DD</sub>	200		600		mW	7, 8
Typical—GV <sub>DD</sub>	300		900		mW	7, 9

**Notes:**

1. The values include V<sub>DD</sub>, AV<sub>DD</sub>, AV<sub>DD2</sub>, and LAV<sub>DD</sub> but do not include I/O supply power; see Section 1.7.2, “Power Supply Sizing,” for information on OV<sub>DD</sub> and GV<sub>DD</sub> supply power. One DIMM is used for memory loading.
2. Maximum—FP power is measured at V<sub>DD</sub> = 2.5 V with dynamic power management enabled while running an entirely cache-resident, looping, floating-point multiplication instruction.
3. Maximum—INT power is measured at V<sub>DD</sub> = 2.5 V with dynamic power management enabled while running entirely cache-resident, looping, integer instructions.
4. Power saving mode maximums are measured at V<sub>DD</sub> = 2.5 V while the device is in doze, nap, or sleep mode.
5. Typical power is measured at V<sub>DD</sub> = AV<sub>DD</sub> = 2.5 V, OV<sub>DD</sub> = 3.3 V where a nominal FP value, a nominal INT value, and a value where there is a continuous flush of cache lines with alternating ones and zeros on 64-bit boundaries to local memory are averaged.
6. Power saving mode data measured with only two PCI\_CLKs and two SDRAM\_CLKs enabled.
7. The typical minimum I/O power values were results of the MPC8240 performing cache resident integer operations at the slowest frequency combination of 33:66:166 (PCI:Mem:CPU) MHz.
8. The typical maximum OV<sub>DD</sub> value resulted from the MPC8240 operating at the fastest frequency combination of 66:100:250 (PCI:Mem:CPU) MHz and performing continuous flushes of cache lines with alternating ones and zeros to PCI memory.
9. The typical maximum GV<sub>DD</sub> value resulted from the MPC8240 operating at the fastest frequency combination of 66:100:250 (PCI:Mem:CPU) MHz and performing continuous flushes of cache lines with alternating ones and zeros on 64-bit boundaries to local memory.
10. Power consumption on the PLL supply pins (AV<sub>DD</sub> and AV<sub>DD2</sub>) and the DLL supply pin (LAV<sub>DD</sub>) less than 15 mW. This parameter is guaranteed by design and is not tested.

### 1.4.2 AC Electrical Characteristics

This section provides the AC electrical characteristics for the MPC8240. After fabrication, functional parts are sorted by maximum processor core frequency as shown in Table 6 and tested for conformance to the AC specifications for that frequency. The processor core frequency is determined by the bus (PCI\_SYNC\_IN)

clock frequency and the settings of the PLL\_CFG[0:4] signals. Parts are sold by maximum processor core frequency; see Section 1.9, “Ordering Information,” for information on ordering parts.

### 1.4.2.1 AC Operating Frequency Data

Table 6 provides the operating frequency information for the MPC8240.

**Table 6. Operating Frequency**

At recommended operating conditions (see Table 2) with  $V_{DD} = 3.3\text{ V} \pm 5\%$  and  $V_{DD} = 3.3\text{ V} \pm 5\%$

Characteristic <sup>1</sup>	200 MHz		250 MHz <sup>2</sup>		Unit
	Min	Max	Min	Max	
Processor frequency (CPU)	100	200	100	250	MHz
Memory bus frequency	33–100				MHz
PCI input frequency	25–66				MHz

**Note:**

- 1. Caution:** The PCI\_SYNC\_IN frequency and PLL\_CFG[0:4] settings must be chosen such that the resulting peripheral logic/memory bus frequency and CPU (core) frequency do not exceed their respective maximum or minimum operating frequencies. Refer to the PLL\_CFG[0:4] signal description in Section 1.6, “PLL Configurations,” for valid PLL\_CFG[0:4] settings and PCI\_SYNC\_IN frequencies.
- 2.)** The 250-MHz processor is only available as an R spec part. See Section 1.9.2, “Part Numbers Not Fully Addressed by This Document,” for more information.

### 1.4.2.2 Clock AC Specifications

Table 7 provides the clock AC timing specifications as defined in Section 1.4.2.3, “Input AC Timing Specifications.”

**Table 7. Clock AC Timing Specifications**

At recommended operating conditions (see Table 2) with  $V_{DD} = 3.3\text{ V} \pm 0.3\text{ V}$

Num	Characteristic and Condition <sup>1</sup>	Min	Max	Unit	Notes
1a	Frequency of operation (PCI_SYNC_IN)	25	66	MHz	
1b	PCI_SYNC_IN cycle time	40	15	ns	
2, 3	PCI_SYNC_IN rise and fall times	—	2.0	ns	2
4	PCI_SYNC_IN duty cycle measured at 1.4 V	40	60	%	
5a	PCI_SYNC_IN pulse width high measured at 1.4 V	6	9	ns	3
5b	PCI_SYNC_IN pulse width low measured at 1.4 V	6	9	ns	3
7	PCI_SYNC_IN jitter	—	150	ps	
8a	PCI_CLK[0:4] skew (pin-to-pin)	—	500	ps	
8b	SDRAM_CLK[0:3] skew (pin-to-pin)	—	350	ps	8
10	Internal PLL relock time	—	100	μs	3, 4, 6
15	DLL lock range with DLL_STANDAR = 1	$0 \leq (NT_{clk} - t_{loop} - t_{fix0}) \leq 7$		ns	7

**Table 7. Clock AC Timing Specifications (continued)**

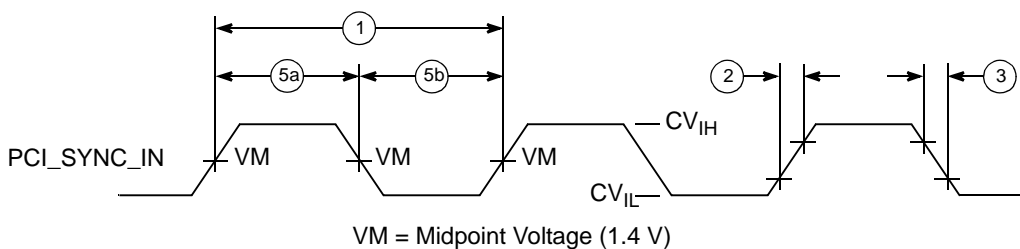
At recommended operating conditions (see Table 2) with  $V_{DD} = 3.3 \text{ V} \pm 0.3 \text{ V}$

Num	Characteristic and Condition <sup>1</sup>	Min	Max	Unit	Notes
16	DLL lock range with DLL_STANDAR = 0 (default)	$0 \leq (NT_{clk} - T_{clk}/2 - t_{loop} - t_{fix0}) \leq 7$		ns	7
17	Frequency of operation (OSC_IN)	25	66	MHz	
18	OSC_IN cycle time	40	15	ns	
19	OSC_IN rise and fall times	—	5	ns	5
20	OSC_IN duty cycle measured at 1.4 V	40	60	%	
21	OSC_IN frequency stability	—	100	ppm	
22	OSC_IN $V_{IH}$ (loaded)	2.0		V	
23	OSC_IN $V_{IL}$ (loaded)		0.8	V	

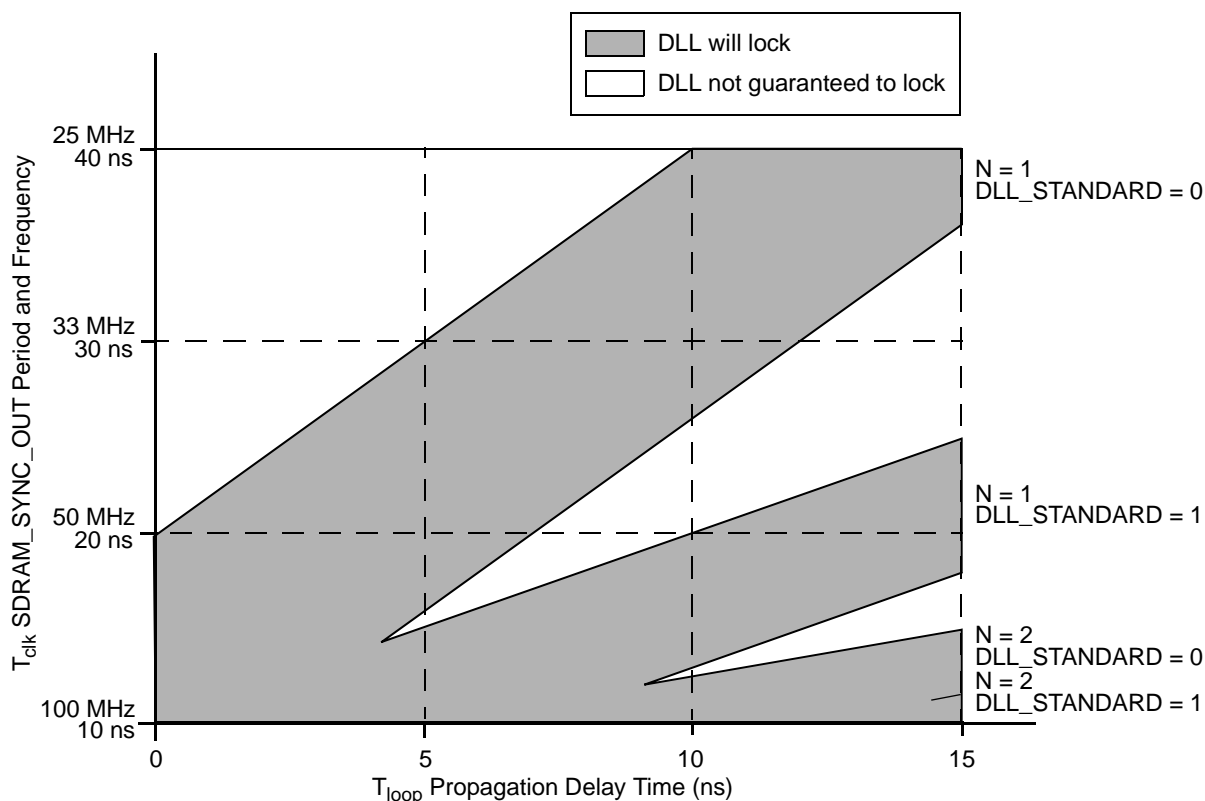
**Notes:**

1. These specifications are for the default driver strengths indicated in Table 4.
2. Rise and fall times for the PCI\_SYNC\_IN input are measured from 0.4 to 2.4 V.
3. Specification value at maximum frequency of operation.
4. Relock time is guaranteed by design and characterization. Relock time is not tested.
5. Rise and fall times for the OSC\_IN input are guaranteed by design and characterization. OSC\_IN input rise and fall times are not tested.
6. Relock timing is guaranteed by design. PLL-relock time is the maximum amount of time required for PLL lock after a stable  $V_{DD}$  and PCI\_SYNC\_IN are reached during the reset sequence. This specification also applies when the PLL has been disabled and subsequently re-enabled during sleep mode. Also note that HRST\_CPU/HRST\_CTRL must be held asserted for a minimum of 255 bus clocks after the PLL-relock time during the reset sequence.
7. DLL\_STANDAR is bit 7 of the PMC2 register <72>. N is a non-zero integer (1 or 2).  $T_{clk}$  is the period of one SDRAM\_SYNC\_OUT clock cycle in ns.  $t_{loop}$  is the propagation delay of the DLL synchronization feedback loop (PC board runner) from SDRAM\_SYNC\_OUT to SDRAM\_SYNC\_IN in ns; 6.25 inches of loop length (unloaded PC board runner) corresponds to approximately 1 ns of delay.  $t_{fix0}$  is a fixed delay inherent in the design when the DLL is at tap point 0 and the DLL is contributing no delay;  $t_{fix0}$  equals approximately 3 ns. See Figure 7 for DLL3 locking ranges.
8. Pin-to-pin skew includes quantifying the additional amount of clock skew (or jitter) from the DLL besides any intentional skew added to the clocking signals from the variable length DLL synchronization feedback loop, that is, the amount of variance between the internal sys\_logic\_clk and the SDRAM\_SYNC\_IN signal after the DLL is locked. While pin to pin skew between SDRAM\_CLKs can be measured, the relationship between the internal sys\_logic\_clk and the external SDRAM\_SYNC\_IN cannot be measured and is guaranteed by design.

Figure 6 shows the PCI\_SYNC\_IN input clock timing diagram, and Figure 7 shows the DLL locking range loop delay versus frequency of operation.



**Figure 6. PCI\_SYNC\_IN Input Clock Timing Diagram**



**Figure 7. DLL Locking Range Loop Delay vs. Frequency of Operation**

### 1.4.2.3 Input AC Timing Specifications

Table 8 provides the input AC timing specifications. See Figure 8 and Figure 9 for the input-output timing diagrams referenced to SDRAM\_SYNC\_IN and PCI\_SYNC\_IN, respectively.

**Table 8. Input AC Timing Specifications**

At recommended operating conditions (see Table 2) with  $V_{DD} = 3.3 \text{ V} \pm 0.3 \text{ V}$

Num	Characteristic	Min	Max	Unit	Notes
10a	PCI input signals valid to PCI_SYNC_IN (input setup)	2.0	—	ns	2, 3
10b1	Memory control and data input signals in flow through mode valid to SDRAM_SYNC_IN (input setup)	3.0	—	ns	1, 3
10b2	Memory control and data input signals in registered/in-line mode valid to SDRAM_SYNC_IN (input setup)	2.5	—	ns	1, 3
10b3	Memory control and data signals accessing non-DRAM valid to SDRAM_SYNC_IN (input setup)	3.0	—	ns	1, 3
10c	PIC, miscellaneous debug input signals valid to SDRAM_SYNC_IN (input setup)	3.0	—	ns	1, 3
10d	I <sup>2</sup> C input signals valid to SDRAM_SYNC_IN (input setup)	2.0	—	ns	1, 3
10e	Mode select inputs valid to $\overline{\text{HRST\_CPU/HRST\_CTRL}}$ (input setup)	$9 \times t_{\text{CLK}}$	—	ns	1, 3–5

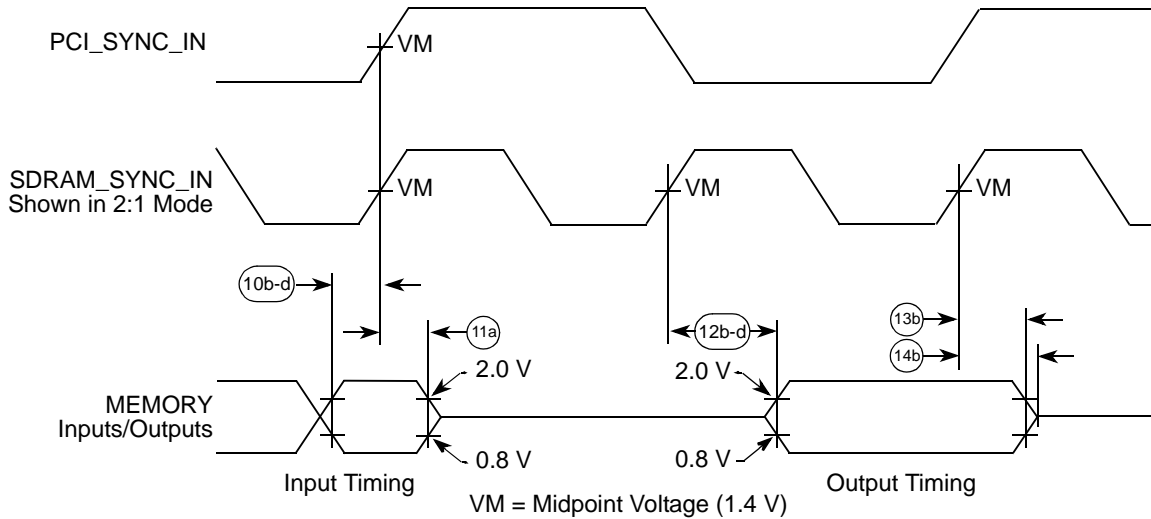
**Table 8. Input AC Timing Specifications (continued)**

At recommended operating conditions (see Table 2) with  $V_{DD} = 3.3 \text{ V} \pm 0.3 \text{ V}$

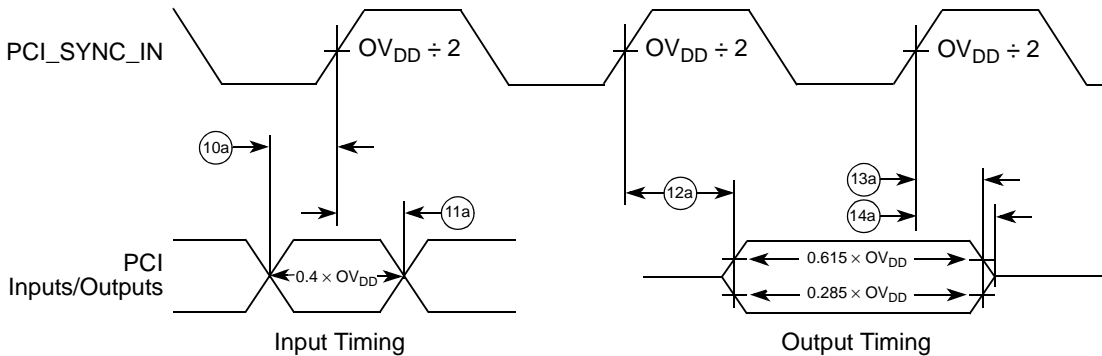
Num	Characteristic	Min	Max	Unit	Notes
11a	PCI_SYNC_IN (SDRAM_SYNC_IN) to inputs invalid (input hold)	1.0	—	ns	1, 2, 3
11b	HRST_CPU/HRST_CTRL to mode select inputs invalid (input hold)	0	—	ns	1, 3, 5

**Notes:**

- All memory and related interface input signal specifications are measured from the TTL level (0.8 or 2.0 V) of the signal in question to the  $V_M = 1.4 \text{ V}$  of the rising edge of the memory bus clock, SDRAM\_SYNC\_IN. SDRAM\_SYNC\_IN is the same as PCI\_SYNC\_IN in 1:1 mode, but is twice the frequency in 2:1 mode (processor/memory bus clock rising edges occur on every rising and falling edge of PCI\_SYNC\_IN). See Figure 8.
- All PCI signals are measured from  $OV_{DD}/2$  of the rising edge of PCI\_SYNC\_IN to  $0.4 \times OV_{DD}$  of the signal in question for 3.3-V PCI signaling levels. See Figure 9.
- Input timings are measured at the pin.
- $t_{CLK}$  is the time of one SDRAM\_SYNC\_IN clock cycle.
- All mode select input signals specifications are measured from the TTL level (0.8 or 2.0 V) of the signal in question to the  $V_M = 1.4 \text{ V}$  of the rising edge of the HRST\_CPU/HRST\_CTRL signal. See Figure 10.

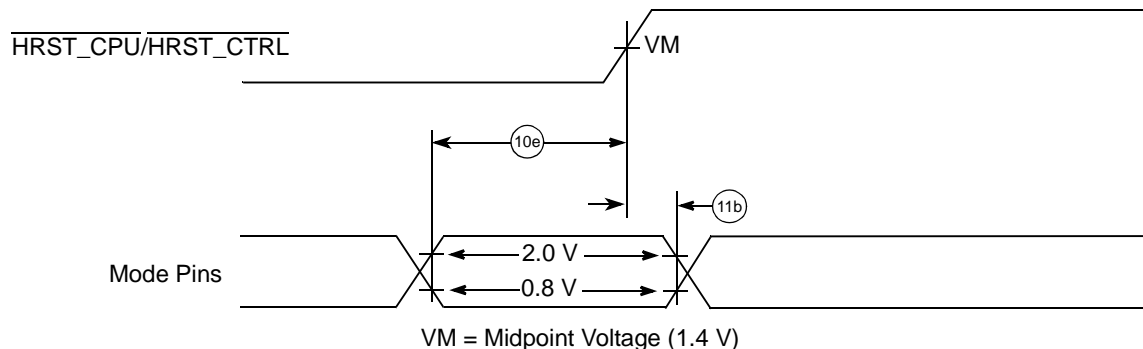


**Figure 8. Input-Output Timing Diagram Referenced to SDRAM\_SYNC\_IN**



**Figure 9. Input-Output Timing Diagram Referenced to PCI\_SYNC\_IN**

Figure 10 shows the input timing diagram for mode select signals.



**Figure 10. Input Timing Diagram for Mode Select Signals**

### 1.4.2.4 Output AC Timing Specification

Table 9 provides the processor bus AC timing specifications for the MPC8240. See Figure 8 and Figure 9 for the input-output timing diagrams referenced to SDRAM\_SYNC\_IN and PCI\_SYNC\_IN, respectively. Figure 11 shows the AC test load for the MPC8240.

**Table 9. Output AC Timing Specifications**

At recommended operating conditions (see Table 2) with  $V_{DD} = 3.3 \text{ V} \pm 0.3 \text{ V}$

Num	Characteristic <sup>3, 6</sup>	Min	Max	Unit	Notes
12a	PCI_SYNC_IN to output valid, 66 MHz PCI, with $\overline{MCP}$ in the default logic 1 state and CKE pulled down to logic 0 state (see Figure 10)	—	6.0	ns	2, 4
	PCI_SYNC_IN to output valid, 33 MHz PCI, with $\overline{MCP}$ and CKE in the default logic 1 state (see Figure 10)	—	8.0	ns	2, 4
12b1	SDRAM_SYNC_IN to output valid (for memory control address and data signals accessing DRAM in flow-through mode)	—	7.0	ns	1
12b2	SDRAM_SYNC_IN to output valid (for memory control address and data signals accessing DRAM in registered mode)	—	6.0	ns	1
12b3	SDRAM_SYNC_IN to output valid (for memory control address and data signals accessing non-DRAM)	—	7.0	ns	1
12c	SDRAM_SYNC_IN to output valid (for all others)	—	7.0	ns	1
12d	SDRAM_SYNC_IN to output valid (for I <sup>2</sup> C)	—	5.0	ns	1
13a	Output hold, 66 MHz PCI, with $\overline{MCP}$ in the default logic 1 state and CKE pulled down to logic 0 state (see Figure 10)	1.0	—	ns	2, 4, 5
	Output hold, 33 MHz PCI, with $\overline{MCP}$ and CKE in the default logic 1 state (see Figure 10)	2.0	—	ns	2, 4, 5
13b	Output hold (all others)	0	—	ns	1
14a	PCI_SYNC_IN to output high impedance (for PCI)	—	14.0	ns	2, 4



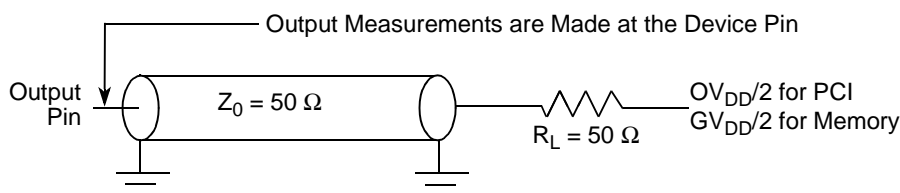
**Table 9. Output AC Timing Specifications (continued)**

At recommended operating conditions (see Table 2) with  $V_{DD} = 3.3\text{ V} \pm 0.3\text{ V}$

Num	Characteristic <sup>3, 6</sup>	Min	Max	Unit	Notes
14b	SDRAM_SYNC_IN to output high impedance (for all others)	—	4.0	ns	1

**Notes:**

- All memory and related interface output signal specifications are specified from the  $V_M = 1.4\text{ V}$  of the rising edge of the memory bus clock, SDRAM\_SYNC\_IN to the TTL level (0.8 or 2.0 V) of the signal in question. SDRAM\_SYNC\_IN is the same as PCI\_SYNC\_IN in 1:1 mode, but is twice the frequency in 2:1 mode (processor/memory bus clock rising edges occur on every rising and falling edge of PCI\_SYNC\_IN). See Figure 8.
- All PCI signals are measured from  $OV_{DD}/2$  of the rising edge of PCI\_SYNC\_IN to  $0.285 \times OV_{DD}$  or  $0.615 \times OV_{DD}$  of the signal in question for 3.3-V PCI signaling levels. See Figure 9.
- All output timings assume a purely resistive 50- $\Omega$  load (see Figure 11). Output timings are measured at the pin; time-of-flight delays must be added for trace lengths, vias, and connectors in the system.
- PCI based signals are composed of the following signals:  $\overline{\text{LOCK}}$ ,  $\overline{\text{IRDY}}$ ,  $\overline{\text{C/BE}}[0:3]$ ,  $\overline{\text{PAR}}$ ,  $\overline{\text{TRDY}}$ ,  $\overline{\text{FRAME}}$ ,  $\overline{\text{STOP}}$ ,  $\overline{\text{DEVSEL}}$ ,  $\overline{\text{PERR}}$ ,  $\overline{\text{SERR}}$ ,  $\text{AD}[0:31]$ ,  $\text{REQ}[4:0]$ ,  $\overline{\text{GNT}}[4:0]$ ,  $\overline{\text{IDSEL}}$ , and  $\overline{\text{INTA}}$ .
- PCI hold times can be varied; see Section 1.4.2.4.1, "PCI Signal Output Hold Timing," for information on programmable PCI output hold times. The values shown for item 13a are for PCI compliance.
- These specifications are for the default driver strengths indicated in Table 4.



**Figure 11. AC Test Load for the MPC8240**

### 1.4.2.4.1 PCI Signal Output Hold Timing

In order to meet minimum output hold specifications relative to PCI\_SYNC\_IN for both 33- and 66-MHz PCI systems, the MPC8240 has a programmable output hold delay for PCI signals. The initial value of the output hold delay is determined by the values on the  $\overline{\text{MCP}}$  and  $\overline{\text{CKE}}$  reset configuration signals. Further output hold delay values are available through programming the PCI\_HOLD\_DEL value of the PMCR2 configuration register.

Table 10 describes the bit values for the PCI\_HOLD\_DEL values in PMCR2.

**Table 10. Power Management Configuration Register 2 at 0x72**

Bit	Name	Reset Value	Description
6–4	PCI_HOLD_DEL	xx0	<p>PCI output hold delay values relative to PCI_SYNC_IN. The initial values of bits 6 and 5 are determined by the reset configuration pins <math>\overline{MCP}</math> and CKE, respectively. As these two pins have internal pull-up resistors, the default value after reset is 0b110.</p> <p>Although the minimum hold times are guaranteed at shown values, changes in the actual hold time can be made by incrementing or decrementing the value in these bit fields of this register through software or hardware configuration. The increment is in approximately 400-picosecond steps. Lowering the value in the 3-bit field decreases the amount of output hold available.</p> <p>000 For Silicon Rev. 1.0/1.1: 66-MHz PCI. Pull-down CKE configuration pin with a 2-k<math>\Omega</math> or less value resistor. This setting guarantees the minimum output hold (item 13a) and the maximum output valid (item 12a) times as specified in Figure 9 are met for a 66-MHz PCI system. See Figure 12.</p> <p>001 Reserved</p> <p>010 Reserved</p> <p>011 Reserved</p> <p>100 For Silicon Rev. 1.2/1.3: 66-MHz PCI. Pull-down CKE configuration pin with a 2-k<math>\Omega</math> or less value resistor. This setting guarantees the minimum output hold (item 13a) and the maximum output valid (item 12a) times as specified in Figure 9 are met for a 66-MHz PCI system. See Figure 12.</p> <p>For Silicon Rev. 1.0/1.1: 33-MHz PCI. This setting guarantees the minimum output hold (item 13a) and the maximum output valid (item 12a) times as specified in Figure 9 are met for a 33-MHz PCI system. See Figure 12.</p> <p>101 Reserved</p> <p>110 For Silicon Rev. 1.2/1.3: 33-MHz PCI. This setting guarantees the minimum output hold (item 13a) and the maximum output valid (item 12a) times as specified in Figure 9 are met for a 33-MHz PCI system. See Figure 12. (Default if reset configuration pins left unconnected.)</p> <p>For Silicon Rev. 1.0/1.1: Default if reset configuration pins left unconnected.</p> <p>111 Reserved</p>

Figure 12 shows the PCI\_HOLD\_DEL effect on output valid and hold time.

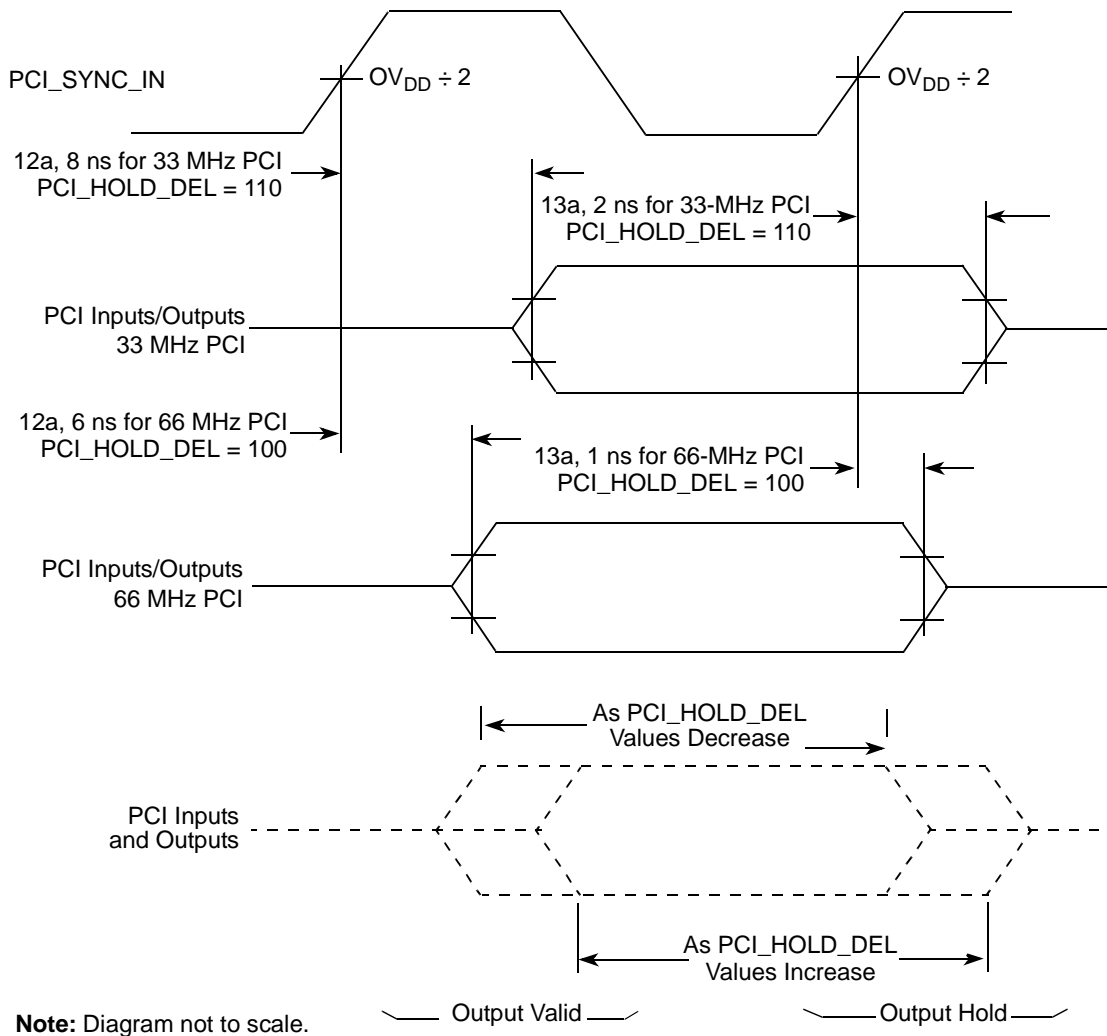


Figure 12. PCI\_HOLD\_DEL Effect on Output Valid and Hold Time

### 1.4.2.5 I<sup>2</sup>C AC Timing Specifications

Table 11 provides the I<sup>2</sup>C input AC timing specifications for the MPC8240.

Table 11. I<sup>2</sup>C Input AC Timing Specifications

At recommended operating conditions (see Table 2) with LV<sub>DD</sub> = 3.3 V ± 0.3 V

Num	Characteristic	Min	Max	Unit	Notes
1	Start condition hold time	4.0	—	CLKs	1,2
2	Clock low period (the time before the MPC8240 will drive SCL low as a transmitting slave after detecting SCL low as driven by an external master)	$8.0 + (16 \times 2^{\text{FDR}[4:2]}) \times (5 - 4(\{\text{FDR}[5], \text{FDR}[1]\} == \text{b}'10\}) - 3(\{\text{FDR}[5], \text{FDR}[1]\} == \text{b}'11\}) - 2(\{\text{FDR}[5], \text{FDR}[1]\} == \text{b}'00\}) - 1(\{\text{FDR}[5], \text{FDR}[1]\} == \text{b}'01\}))$	—	CLKs	1, 2, 4, 5
3	SCL/SDA rise time (from 0.5 to 2.4 V)	—	1	ms	

**Table 11. I<sup>2</sup>C Input AC Timing Specifications**

At recommended operating conditions (see Table 2) with LV<sub>DD</sub> = 3.3 V ± 0.3 V

Num	Characteristic	Min	Max	Unit	Notes
4	Data hold time	0	—	ns	2
5	SCL/SDA fall time (from 2.4 to 0.5 V)	—	1	ms	
6	Clock high period (time needed to either receive a data bit or generate a START or STOP)	5.0	—	CLKs	1, 2, 5
7	Data setup time	3.0	—	ns	3
8	Start condition setup time (for repeated start condition only)	4.0	—	CLKs	1, 2
9	Stop condition setup time	4.0	—	CLKs	1, 2

**Notes:**

1. Units for these specifications are in SDRAM\_CLK units.
2. The actual values depend on the setting of the digital filter frequency sampling rate (DFFSR) bits in the frequency divider register I2CFDR. Therefore, the noted timings in this table are all relative to qualified signals. The qualified SCL and SDA are delayed signals from what is seen in real time on the I<sup>2</sup>C bus. The qualified SCL and SDA signals are delayed by the SDRAM\_CLK clock times DFFSR times two plus one SDRAM\_CLK clock. The resulting delay value is added to the value in the table (where this note is referenced). See Figure 13.
3. Timing is relative to the sampling clock (not SCL).
4. FDR[x] refers to the frequency divider register I2CFDR bit *n*.
5. Input clock low and high periods in combination with the FDR value in the frequency divider register (I2CFDR) determine the maximum I<sup>2</sup>C input frequency. See Table 12.

Table 12 provides the I<sup>2</sup>C frequency divider register (I2CFDR) information for the MPC8240.

**Table 12. MPC8240 Maximum I<sup>2</sup>C Input Frequency**

FDR Hex <sup>2</sup>	Divider <sup>3</sup> (Dec)	Maximum I <sup>2</sup> C Input Frequency <sup>1</sup>		
		SDRAM_CLK @ 33 MHz	SDRAM_CLK @ 50 MHz	SDRAM_CLK @ 100 MHz
20, 21	160, 192	1.13 MHz	1.72 MHz	3.44 MHz
22, 23, 24, 25	224, 256, 320, 384	733	1.11 MHz	2.22 MHz
0, 1	288, 320	540	819	1.63 MHz
2, 3, 26, 27, 28, 29	384, 448, 480, 512, 640, 768	428	649	1.29 MHz
4, 5	576, 640	302	458	917
6, 7, 2A, 2B, 2C, 2D	768, 896, 960, 1024, 1280, 1536	234	354	709
8, 9	1152, 1280	160	243	487
A, B, 2E, 2F, 30, 31	1536, 1792, 1920, 2048, 2560, 3072	122	185	371
C, D	2304, 2560	83	125	251
E, F, 32, 33, 34, 35	3072, 3584, 3840, 4096, 5120, 6144	62	95	190
10, 11	4608, 5120	42	64	128
12, 13, 36, 37, 38, 39	6144, 7168, 7680, 8192, 10240, 12288	31	48	96

**Table 12. MPC8240 Maximum I<sup>2</sup>C Input Frequency (continued)**

FDR Hex <sup>2</sup>	Divider <sup>3</sup> (Dec)	Maximum I <sup>2</sup> C Input Frequency <sup>1</sup>		
		SDRAM_CLK @ 33 MHz	SDRAM_CLK @ 50 MHz	SDRAM_CLK @ 100 MHz
14, 15	9216, 10240	21	32	64
16, 17, 3A, 3B, 3C, 3D	12288, 14336, 15360, 16384, 20480, 24576	16	24	48
18, 19	18432, 20480	10	16	32
1A, 1B, 3E, 3F	24576, 28672, 30720, 32768	8	12	24
1C, 1D	36864, 40960	5	8	16
1E, 1F	49152, 61440	4	6	12

**Notes:**

1. Values are in KHz, unless otherwise specified.
2. FDR Hex and Divider (Dec) values are listed in corresponding order.
3. Multiple Divider (Dec) values will generate the same input frequency, but each Divider (Dec) value will generate a unique output frequency as shown in Table 13.

Table 13 provides the I<sup>2</sup>C output AC timing specifications for the MPC8240.

**Table 13. I<sup>2</sup>C Output AC Timing Specifications**

At recommended operating conditions (see Table 2) with LV<sub>DD</sub> = 3.3 V ± 0.3 V

Num	Characteristic	Min	Max	Unit	Notes
1	Start condition hold time	$(FDR[5] == 0) \times (D_{FDR}/16)/2N + (FDR[5] == 1) \times (D_{FDR}/16)/2M$	—	CLKs	1, 2, 5
2	Clock low period	$D_{FDR}/2$	—	CLKs	1, 2, 5
3	SCL/SDA rise time (from 0.5 to 2.4 V)	—	—	ms	3
4	Data hold time	$8.0 + (16 \times 2^{FDR[4:2]}) \times (5 - 4(\{FDR[5], FDR[1]\} == b'10) - 3(\{FDR[5], FDR[1]\} == b'11) - 2(\{FDR[5], FDR[1]\} == b'00) - 1(\{FDR[5], FDR[1]\} == b'01))$	—	CLKs	1, 2, 5
5	SCL/SDA fall time (from 2.4 to 0.5 V)	—	< 5	ns	4
6	Clock high time	$D_{FDR}/2$	—	CLKs	1, 2, 5
7	Data setup time (MPC8240 as a master only)	$(D_{FDR}/2) - (\text{Output data hold time})$	—	CLKs	1, 5
8	Start condition setup time (for repeated start condition only)	$D_{FDR} + (\text{Output start condition hold time})$	—	CLKs	1, 2, 5

**Table 13. I<sup>2</sup>C Output AC Timing Specifications (continued)**

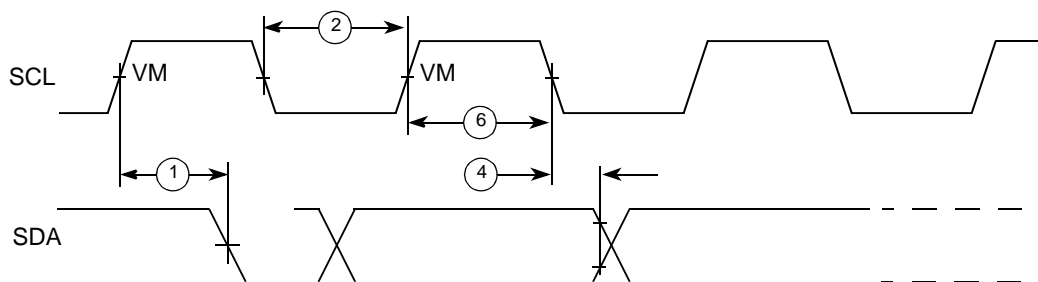
At recommended operating conditions (see Table 2) with LV<sub>DD</sub> = 3.3 V ± 0.3 V

Num	Characteristic	Min	Max	Unit	Notes
9	Stop condition setup time	4.0	—	CLKs	1, 2

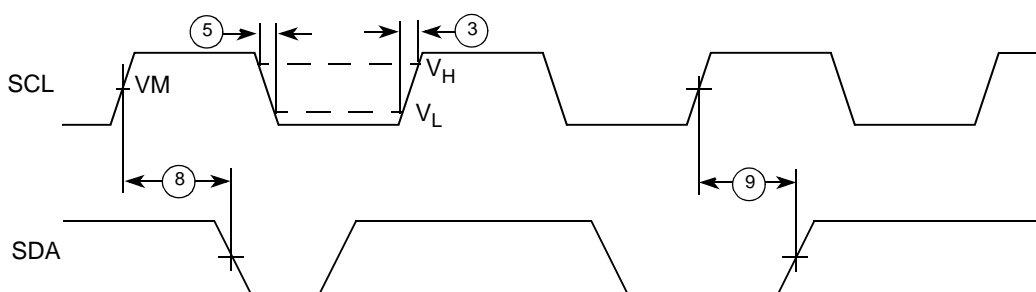
**Notes:**

- Units for these specifications are in SDRAM\_CLK units.
- The actual values depend on the setting of the digital filter frequency sampling rate (DFFSR) bits in the frequency divider register I2CFDR. Therefore, the noted timings in this table are all relative to qualified signals. The qualified SCL and SDA are delayed signals from what is seen in real time on the I<sup>2</sup>C bus. The qualified SCL and SDA signals are delayed by the SDRAM\_CLK clock times DFFSR times two plus one SDRAM\_CLK clock. The resulting delay value is added to the value in the table (where this note is referenced). See Figure 14.
- Since SCL and SDA are open-drain type outputs, which the MPC8240 can only drive low, the time required for SCL or SDA to reach a high level depends on external signal capacitance and pull-up resistor values.
- Specified at a nominal 50-pF load.
- D<sub>FDR</sub> is the decimal divider number indexed by the value of FDR[5:0]. Refer to the I<sup>2</sup>C Interface chapter's serial bit clock frequency divider selections table. FDR[n] refers to the frequency divider register I2CFDR bit n. N is equal to a variable number that would make the result of the divide (data hold time value) equal to a number less than 16. M is equal to a variable number that would make the result of the divide (data hold time value) equal to a number less than 9.

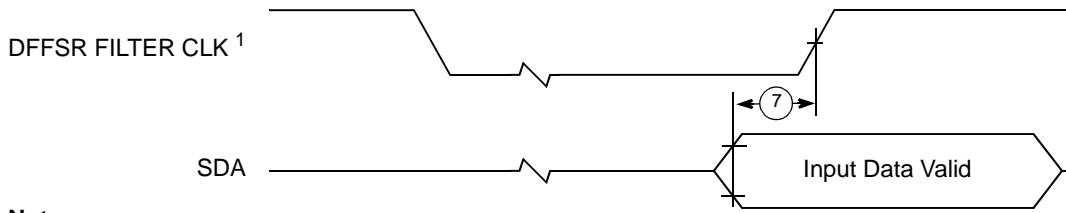
Figure 13 through Figure 16 show I<sup>2</sup>C timings.



**Figure 13. I<sup>2</sup>C Timing Diagram I**



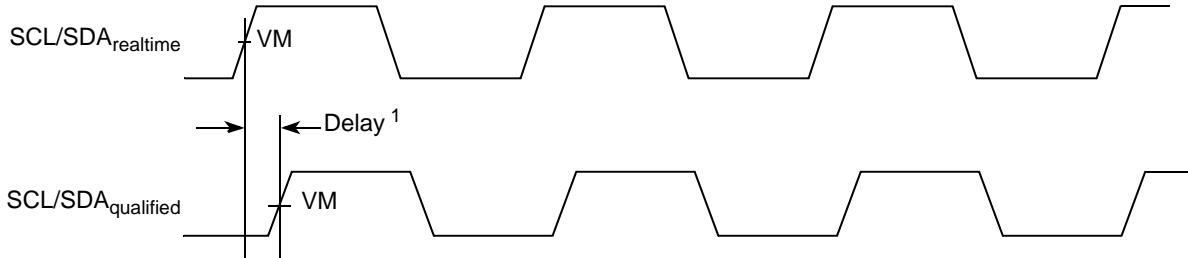
**Figure 14. I<sup>2</sup>C Timing Diagram II**



**Note:**

1. DFFSR filter clock is the SDRAM\_CLK clock times DFFSR value.

**Figure 15. I<sup>2</sup>C Timing Diagram III**



**Note:**

1. The delay is the local memory clock times DFFSR times 2 plus 1 local memory clock.

**Figure 16. I<sup>2</sup>C Timing Diagram IV (Qualified Signal)**

**1.4.2.6 PIC Serial Interrupt Mode AC Timing Specifications**

Table 14 provides the PIC serial interrupt mode AC timing specifications for the MPC8240.

**Table 14. PIC Serial Interrupt Mode AC Timing Specifications**

At recommended operating conditions (see Table 2) with LV<sub>DD</sub> = 3.3 V ± 0.3 V

Num	Characteristic	Min	Max	Unit	Notes
1	S_CLK frequency	1/14 SDRAM_SYNC_IN	1/2 SDRAM_SYNC_IN	MHz	1
2	S_CLK duty cycle	40	60	%	
3	S_CLK output valid time	—	6	ns	
4	Output hold time	0	—	ns	
5	S_FRAME, S_RST output valid time	—	1 sys_logic_clk period + 6	ns	2
6	S_INT input setup time to S_CLK	1 sys_logic_clk period + 2	—	ns	2

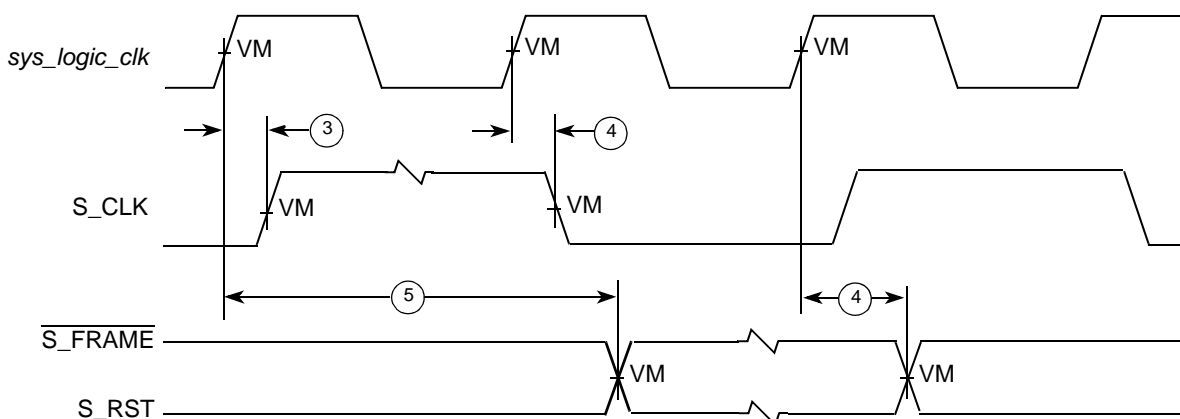
**Table 14. PIC Serial Interrupt Mode AC Timing Specifications (continued)**

At recommended operating conditions (see Table 2) with  $V_{DD} = 3.3\text{ V} \pm 0.3\text{ V}$

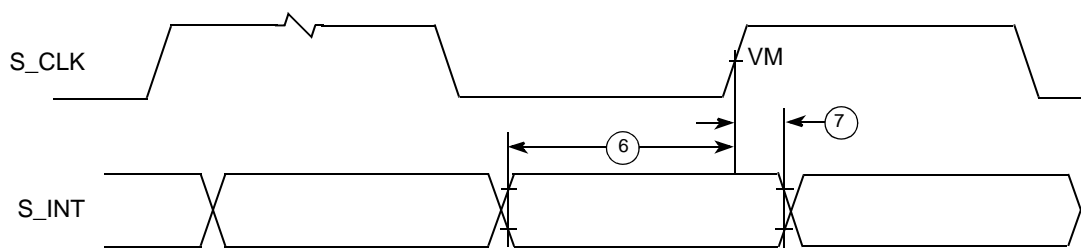
Num	Characteristic	Min	Max	Unit	Notes
7	S_INT inputs invalid (hold time) to S_CLK	—	0	ns	2

**Notes:**

1. See the *MPC8240 Integrated Processor User's Manual* for a description of the PIC interrupt control register (ICR) describing S\_CLK frequency programming.
2. S\_RST, S\_FRAME, and S\_INT are shown in Figure 17. Figure 18 depicts timing relationships to sys\_logic\_clk and S\_CLK and does not describe functional relationships between S\_RST, S\_FRAME, and S\_INT. See the *MPC8240 Integrated Processor User's Manual* for a complete description of the functional relationships between these signals.
3. The sys\_logic\_clk waveform is the clocking signal of the internal peripheral logic from the output of the peripheral logic PLL; sys\_logic\_clk is the same as SDRAM\_SYNC\_IN when the SDRAM\_SYNC\_OUT to SDRAM\_SYNC\_IN feedback loop is implemented and the DLL is locked. See the *MPC8240 Integrated Processor User's Manual* for a complete clocking description.



**Figure 17. PIC Serial Interrupt Mode Output Timing Diagram**



**Figure 18. PIC Serial Interrupt Mode Input Timing Diagram**



### 1.4.2.7 IEEE 1149.1 (JTAG) AC Timing Specifications

Table 15 provides the JTAG AC timing specifications for the MPC8240 while in the JTAG operating mode.

**Table 15. JTAG AC Timing Specification (Independent of PCI\_SYNC\_IN)**

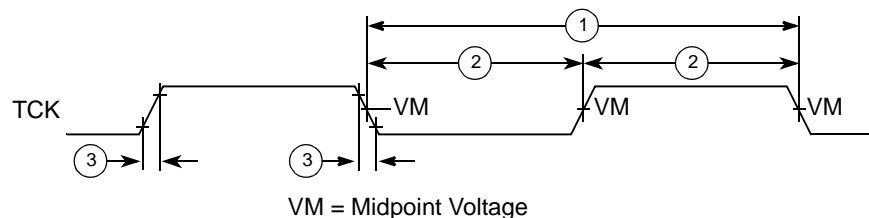
At recommended operating conditions (see Table 2) with  $V_{DD} = 3.3\text{ V} \pm 0.3\text{ V}$

Num	Characteristic <sup>4</sup>	Min	Max	Unit	Notes
	TCK frequency of operation	0	25	MHz	
1	TCK cycle time	40	—	ns	
2	TCK clock pulse width measured at 1.5 V	20	—	ns	
3	TCK rise and fall times	0	3	ns	
4	$\overline{\text{TRST}}$ setup time to TCK falling edge	10	—	ns	1
5	$\overline{\text{TRST}}$ assert time	10	—	ns	
6	Input data setup time	5	—	ns	2
7	Input data hold time	15	—	ns	2
8	TCK to output data valid	0	30	ns	3
9	TCK to output high impedance	0	30	ns	3
10	TMS, TDI data setup time	5	—	ns	
11	TMS, TDI data hold time	15	—	ns	
12	TCK to TDO data valid	0	15	ns	
13	TCK to TDO high impedance	0	15	ns	

**Notes:**

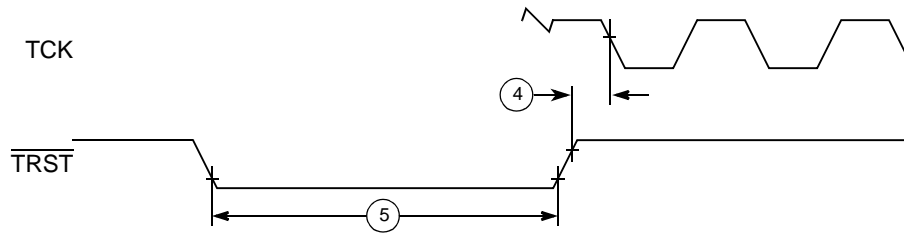
1.  $\overline{\text{TRST}}$  is an asynchronous signal. The setup time is for test purposes only.
2. Non-test (other than TDI and TMS) signal input timing with respect to TCK.
3. Non-test (other than TDO) signal output timing with respect to TCK.
4. Timings are independent of the system clock (PCI\_SYNC\_IN).

Figure 19 shows the JTAG clock input timing diagram.



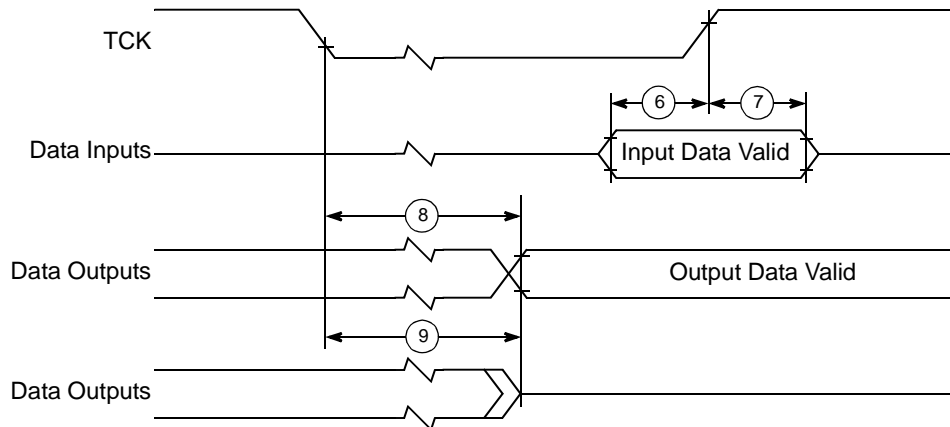
**Figure 19. JTAG Clock Input Timing Diagram**

Figure 20 shows the JTAG  $\overline{\text{TRST}}$  timing diagram.



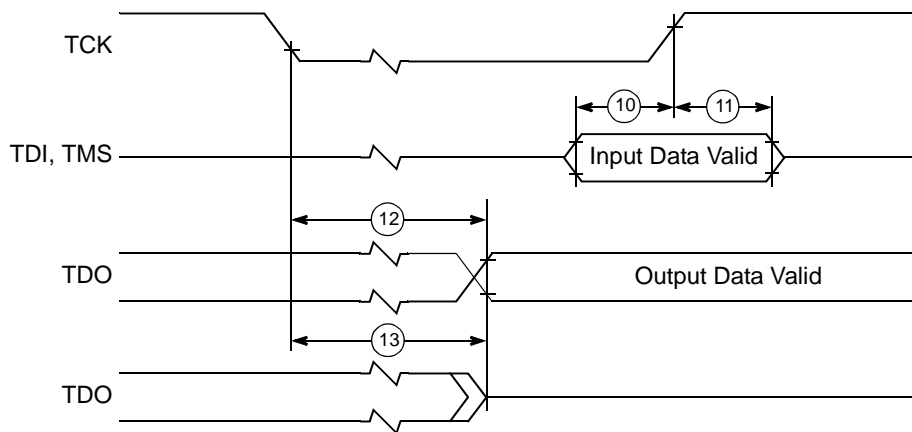
**Figure 20. JTAG  $\overline{\text{TRST}}$  Timing Diagram**

Figure 21 shows the JTAG boundary scan timing diagram.



**Figure 21. JTAG Boundary Scan Timing Diagram**

Figure 22 shows the test access port timing diagram.



**Figure 22. Test Access Port Timing Diagram**

### 1.4.3 Thermal Characteristics

Table 16 provides the package thermal characteristics for the MPC8240.

**Table 16. Package Thermal Characteristics**

Characteristic <sup>1</sup>	Symbol	Value	Unit
Die junction-to-case thermal resistance	$R_{\theta JC}$	1.8	°C/W
Die junction-to-board thermal resistance	$R_{\theta JB}$	4.8	°C/W

**Note:**

1. Refer to Section 1.7, "System Design Information," for details about thermal management.

## 1.5 Package Description

The following sections provide the package parameters and mechanical dimensions for the MPC8240, 352 TBGA package.

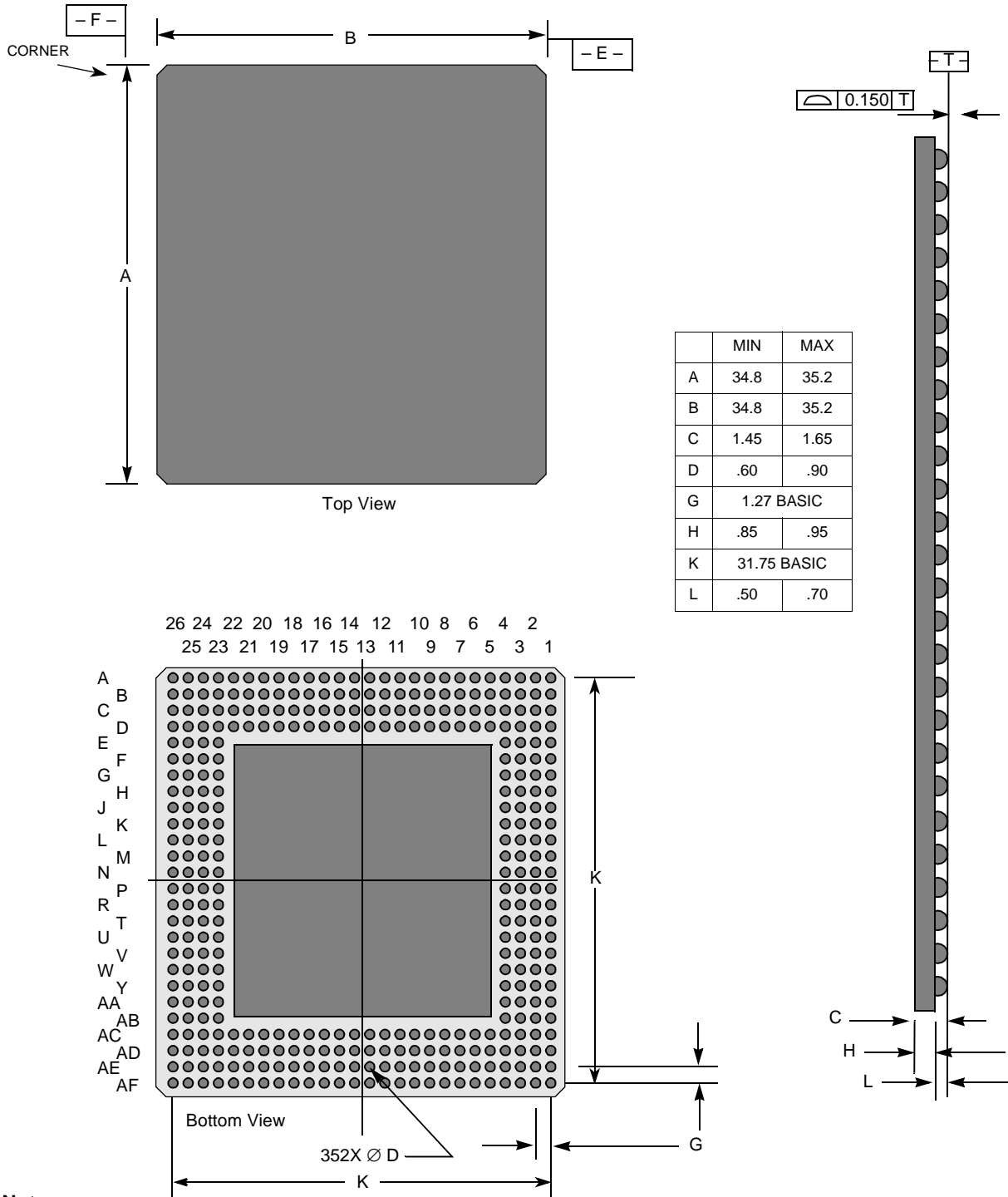
### 1.5.1 Package Parameters

The MPC8240 uses a 35 mm × 35 mm, cavity-down, 352 pin tape ball grid array (TBGA) package. The package parameters are as provided in the following list.

Package outline	35 mm × 35 mm
Interconnects	352
Pitch	1.27 mm
Solder balls	ZU (TBGA)—62 Sn/36 Pb/2 Ag VV (Lead free version of TBGA package)—95.5 Sn/4.0 Ag/0.5 Cu
Solder ball diameter	0.75 mm
Maximum module height	1.65 mm
Co-planarity specification	0.15 mm
Maximum force	6.0 lbs. total, uniformly distributed over package (8 grams/ball)

### 1.5.2 Mechanical Dimensions

Figure 23 provides the mechanical dimensions, top surface, side profile, and pinout for the MPC8240, 352 TBGA package.



- Notes:**
1. Drawing not to scale.
  2. All measurements are in millimeters (mm).

**Figure 23. Mechanical Dimensions and Pinout Assignments for the MPC8240, 352 TBGA**

### 1.5.3 Pinout Listings

Table 17 provides the pinout listing for the MPC8240, 352 TBGA package.

**Table 17. MPC8240 Pinout Listing**

Name	Pin Number	Pin Type	Power Supply	Output Driver Type	Notes
<b>PCI Interface Signals</b>					
$\overline{C}/\overline{BE}[3:0]$	P25 K23 F23 A25	I/O	$OV_{DD}$	DRV_PCI	6, 15
$\overline{DEVSEL}$	H26	I/O	$OV_{DD}$	DRV_PCI	8, 15
$\overline{FRAME}$	J24	I/O	$OV_{DD}$	DRV_PCI	8, 15
$\overline{IRDY}$	K25	I/O	$OV_{DD}$	DRV_PCI	8, 15
$\overline{LOCK}$	J26	Input	$OV_{DD}$	—	8
AD[31:0]	V25 U25 U26 U24 U23 T25 T26 R25 R26 N26 N25 N23 M26 M25 L25 L26 F24 E26 E25 E23 D26 D25 C26 A26 B26 A24 B24 D19 B23 B22 D22 C22	I/O	$OV_{DD}$	DRV_PCI	6, 15
PAR	G25	I/O	$OV_{DD}$	DRV_PCI	15
$\overline{GNT}[3:0]$	W25 W24 W23 V26	Output	$OV_{DD}$	DRV_PCI	6, 15
$\overline{GNT4}/DA5$	W26	Output	$OV_{DD}$	DRV_PCI	7, 15
$\overline{REQ}[3:0]$	Y25 AA26 AA25 AB26	Input	$OV_{DD}$	—	6, 12
$\overline{REQ4}/DA4$	Y26	I/O	$OV_{DD}$	—	12
$\overline{PERR}$	G26	I/O	$OV_{DD}$	DRV_PCI	8, 15, 18
$\overline{SERR}$	F26	I/O	$OV_{DD}$	DRV_PCI	8, 15, 16
$\overline{STOP}$	H25	I/O	$OV_{DD}$	DRV_PCI	8, 15
$\overline{TRDY}$	K26	I/O	$OV_{DD}$	DRV_PCI	8, 15
$\overline{INTA}$	AC26	Output	$OV_{DD}$	DRV_PCI	8, 15, 16
IDSEL	P26	Input	$OV_{DD}$	—	
<b>Memory Interface Signals</b>					
MDL[0:31]	AD17 AE17 AE15 AF15 AC14 AE13 AF13 AF12 AF11 AF10 AF9 AD8 AF8 AF7 AF6 AE5 B1 A1 A3 A4 A5 A6 A7 D7 A8 B8 A10 D10 A12 B11 B12 A14	I/O	$GV_{DD}$	DRV_MEM_DATA	5, 6, 13
MDH[0:31]	AC17 AF16 AE16 AE14 AF14 AC13 AE12 AE11 AE10 AE9 AE8 AC7 AE7 AE6 AF5 AC5 E4 A2 B3 D4 B4 B5 D6 C6 B7 C9 A9 B10 A11 A13 B13 A15	I/O	$GV_{DD}$	DRV_MEM_DATA	6, 13

**Table 17. MPC8240 Pinout Listing (continued)**

Name	Pin Number	Pin Type	Power Supply	Output Driver Type	Notes
$\overline{\text{CAS}}/\text{DQM}[0:7]$	AB1 AB2 K3 K2 AC1 AC2 K1 J1	Output	$\text{GV}_{\text{DD}}$	DRV_MEM_ADDR	6
$\overline{\text{RAS}}/\overline{\text{CS}}[0:7]$	Y4 AA3 AA4 AC4 M2 L2 M1 L1	Output	$\text{GV}_{\text{DD}}$	DRV_MEM_ADDR	6
$\overline{\text{FOE}}$	H1	I/O	$\text{GV}_{\text{DD}}$	DRV_MEM_ADDR	3, 4
$\overline{\text{RCS0}}$	N4	I/O	$\text{GV}_{\text{DD}}$	DRV_MEM_ADDR	3, 4
$\overline{\text{RCS1}}$	N2	Output	$\text{GV}_{\text{DD}}$	DRV_MEM_ADDR	
SDMA[11:0]	N1 R1 R2 T1 T2 U4 U2 U1 V1 V3 W1 W2	Output	$\text{GV}_{\text{DD}}$	DRV_MEM_ADDR	6, 14
SDMA12/SDBA1	P1	Output	$\text{GV}_{\text{DD}}$	DRV_MEM_ADDR	14
SDBA0	P2	Output	$\text{GV}_{\text{DD}}$	DRV_MEM_ADDR	
PAR[0:7]	AF3 AE3 G4 E2 AE4 AF4 D2 C2	I/O	$\text{GV}_{\text{DD}}$	DRV_MEM_DATA	6, 13, 14
$\overline{\text{SDRAS}}$	AD1	Output	$\text{GV}_{\text{DD}}$	DRV_MEM_ADDR	3
$\overline{\text{SDCAS}}$	AD2	Output	$\text{GV}_{\text{DD}}$	DRV_MEM_ADDR	3
CKE	H2	Output	$\text{GV}_{\text{DD}}$	DRV_MEM_ADDR	3, 4
$\overline{\text{WE}}$	AA1	Output	$\text{GV}_{\text{DD}}$	DRV_MEM_ADDR	
$\overline{\text{AS}}$	Y1	Output	$\text{GV}_{\text{DD}}$	DRV_MEM_ADDR	3, 4
<b>PIC Control Signals</b>					
IRQ_0/S_INT	C19	Input	$\text{OV}_{\text{DD}}$	—	19
IRQ_1/S_CLK	B21	I/O	$\text{OV}_{\text{DD}}$	DRV_PCI	19
IRQ_2/S_RST	AC22	I/O	$\text{OV}_{\text{DD}}$	DRV_PCI	19
IRQ_3/ $\overline{\text{S\_FRAME}}$	AE24	I/O	$\text{OV}_{\text{DD}}$	DRV_PCI	19
IRQ_4/ $\overline{\text{L\_INT}}$	A23	I/O	$\text{OV}_{\text{DD}}$	DRV_PCI	19
<b>I<sup>2</sup>C Control Signals</b>					
SDA	AE20	I/O	$\text{OV}_{\text{DD}}$	DRV_STD	10, 16

Table 17. MPC8240 Pinout Listing (continued)

Name	Pin Number	Pin Type	Power Supply	Output Driver Type	Notes
SCL	AF21	I/O	OV <sub>DD</sub>	DRV_STD	10, 16
<b>Clock Out Signals</b>					
PCI_CLK [0:3]	AC25 AB25 AE26 AF25	Output	GV <sub>DD</sub>	DRV_PCI_C LK	6
PCI_CLK4/DA3	AF26	Output	GV <sub>DD</sub>	DRV_PCI_C LK	
PCI_SYNC_OUT	AD25	Output	GV <sub>DD</sub>	DRV_PCI_C LK	
PCI_SYNC_IN	AB23	Input	GV <sub>DD</sub>	—	
SDRAM_CLK [0:3]	D1 G1 G2 E1	Output	GV <sub>DD</sub>	DRV_MEM_ ADDR	6
SDRAM_SYNC_OUT	C1	Output	GV <sub>DD</sub>	DRV_MEM_ ADDR	
SDRAM_SYNC_IN	H3	Input	GV <sub>DD</sub>	—	
CKO/DA1	B15	Output	OV <sub>DD</sub>	DRV_STD	
OSC_IN	AD21	Input	OV <sub>DD</sub>	—	19
<b>Miscellaneous Signals</b>					
$\overline{\text{HRST\_CTRL}}$	A20	Input	OV <sub>DD</sub>	—	
$\overline{\text{HRST\_CPU}}$	A19	Input	OV <sub>DD</sub>	—	
$\overline{\text{MCP}}$	A17	Output	OV <sub>DD</sub>	DRV_STD	3, 4, 17
NMI	D16	Input	OV <sub>DD</sub>	—	
$\overline{\text{SMI}}$	A18	Input	OV <sub>DD</sub>	—	10
$\overline{\text{SRESET}}$	B16	Input	OV <sub>DD</sub>	—	10
TBEN	B14	Input	OV <sub>DD</sub>	—	10
$\overline{\text{QACK/DA0}}$	F2	Output	OV <sub>DD</sub>	DRV_STD	3, 4
$\overline{\text{CHKSTOP\_IN}}$	D14	Input	OV <sub>DD</sub>	—	10
MAA[0:2]	AF2 AF1 AE1	Output	GV <sub>DD</sub>	DRV_MEM_ DATA	3, 4, 6
$\overline{\text{MIV}}$	A16	Output	OV <sub>DD</sub>	DRV_STD	
PMAA[0:2]	AD18 AF18 AE19	Output	OV <sub>DD</sub>	DRV_STD	3, 4, 6,15
TRIG_IN	AF20	Input	OV <sub>DD</sub>	—	10
TRIG_OUT	AC18	I/O	OV <sub>DD</sub>	DRV_STD	

Table 17. MPC8240 Pinout Listing (continued)

Name	Pin Number	Pin Type	Power Supply	Output Driver Type	Notes
<b>Test/Configuration Signals</b>					
PLL_CFG[0:4]/ DA[10:6]	A22 B19 A21 B18 B17	I/O	OV <sub>DD</sub>	—	4, 6
$\overline{\text{TEST0}}$	AD22	Input	OV <sub>DD</sub>	—	1, 9
$\overline{\text{TEST1}}$	B20	Input	OV <sub>DD</sub>	—	9, 10
$\overline{\text{TEST2}}$	Y2	Input	GV <sub>DD</sub>	—	11
TCK	AF22	Input	OV <sub>DD</sub>	—	9, 12
TDI	AF23	Input	OV <sub>DD</sub>	—	9, 12
TDO	AC21	Output	OV <sub>DD</sub>	DRV_PCI	
TMS	AE22	Input	OV <sub>DD</sub>	—	9, 12
$\overline{\text{TRST}}$	AE23	Input	OV <sub>DD</sub>	—	9, 12
<b>Power and Ground Signals</b>					
GND	AA2 AA23 AC12 AC15 AC24 AC3 AC6 AC9 AD11 AD14 AD16 AD19 AD23 AD4 AE18 AE2 AE21 AE25 B2 B25 B6 B9 C11 C13 C16 C23 C4 C8 D12 D15 D18 D21 D24 D3 F25 F4 H24 J25 J4 L24 L3 M23 M4 N24 P3 R23 R4 T24 T3 V2 V23 W3	Ground	—	—	
LV <sub>DD</sub>	AC20 AC23 D20 D23 G23 P23 Y23	Reference voltage 3.3 V, 5.0 V	LV <sub>DD</sub>	—	
GV <sub>DD</sub>	AB3 AB4 AC10 AC11 AC8 AD10 AD13 AD15 AD3 AD5 AD7 C10 C12 C3 C5 C7 D13 D5 D9 E3 G3 H4 K4 L4 N3 P4 R3 U3 V4 Y3	Power for memory drivers 2.5 V, 3.3 V	GV <sub>DD</sub>	—	
OV <sub>DD</sub>	AB24 AD20 AD24 C14 C20 C24 E24 G24 J23 K24 M24 P24 T23 Y24	PCI/Std 3.3 V	OV <sub>DD</sub>	—	
V <sub>DD</sub>	AA24 AC16 AC19 AD12 AD6 AD9 C15 C18 C21 D11 D8 F3 H23 J3 L23 M3 R24 T4 V24 W4	Power for core 2.5 V	V <sub>DD</sub>	—	
LAV <sub>DD</sub>	D17	Power for DLL 2.5 V	LAV <sub>DD</sub>	—	
AV <sub>DD</sub>	C17	Power for PLL (CPU core logic) 2.5 V	AV <sub>DD</sub>	—	



Table 17. MPC8240 Pinout Listing (continued)

Name	Pin Number	Pin Type	Power Supply	Output Driver Type	Notes
AV <sub>DD2</sub>	AF24	Power for PLL (peripheral logic) 2.5 V	AV <sub>DD2</sub>	—	
<b>Manufacturing Pins</b>					
DA2	C25	Output	OV <sub>DD</sub>	DRV_PCI	2
DA[11:13]	AD26 AF17 AF19	Output	OV <sub>DD</sub>	DRV_PCI	2, 6
DA[14:15]	F1 J2	Output	GV <sub>DD</sub>	DRV_MEM_ADDR	2, 6

**Notes:**

- Place pull-up resistors of 120  $\Omega$  or less on the  $\overline{\text{TEST0}}$  pin.
- Treat these pins as no connects unless using debug address functionality.
- This pin has an internal pull-up resistor that is enabled only when the MPC8240 is in the reset state. The value of the internal pull-up resistor is not guaranteed but is sufficient to ensure that a 1 is read into configuration bits during reset.
- This pin is a reset configuration pin.
- DL[0] is a reset configuration pin and has an internal pull-up resistor that is enabled only when the MPC8240 is in the reset state. The value of the internal pull-up resistor is not guaranteed, but is sufficient to ensure that a one is read into configuration bits during reset.
- Multi-pin signals such as AD[0:31] or DL[0:31] have their physical package pin numbers listed in order corresponding to the signal names. Example: AD0 is on pin C22, AD1 is on pin D22,...AD31 is on pin V25.
- $\overline{\text{GNT4}}$  is a reset configuration pin and has an internal pull-up resistor that is enabled only when the MPC8240 is in the reset state. The value of the internal pull-up resistor is not guaranteed but is sufficient to ensure that a one is read into configuration bits during reset.
- Recommend a weak pull-up resistor (2–10 k $\Omega$ ) be placed on this PCI control pin to LV<sub>DD</sub>.
- V<sub>IH</sub> and V<sub>IL</sub> for these signals are the same as the PCI V<sub>IH</sub> and V<sub>IL</sub> entries in Table 3.
- Recommend a weak pull-up resistor (2–10 k $\Omega$ ) be placed on this pin to OV<sub>DD</sub>.
- Recommend a weak pull-up resistor (2–10 k $\Omega$ ) be placed on this pin to GV<sub>DD</sub>.
- This pin has an internal pull-up resistor; the value of the internal pull-up resistor is not guaranteed, but is sufficient to prevent unused inputs from floating.
- Output valid specifications for this pin are memory interface mode dependent (registered or flow-through), see Table 9.
- Non-DRAM access output valid specification applies to this pin during non-DRAM accesses, see specification 12b3 in Table 9.
- This pin is affected by programmable PCI\_HOLD\_DEL parameter, see Section 1.4.2.4.1, "PCI Signal Output Hold Timing."
- This pin is an open drain signal.
- This pin can be programmed to be driven (default) or can be programmed to be open drain; see the PMCR2 register description in the *MPC8240 Integrated Processor User's Manual*, for details.
- This pin is a sustained three-state pin as defined by the *PCI Local Bus Specification*.
- Maximum input voltage tolerance is LV<sub>DD</sub>-based. See Table 2 for details.

## 1.6 PLL Configurations

The MPC8240 internal PLLs are configured by the PLL\_CFG[0:4] signals. For a given PCI\_SYNC\_IN (PCI bus) frequency, the PLL configuration signals set both the peripheral logic/memory bus PLL (VCO) frequency of operation for the PCI-to-memory frequency multiplying and the MPC603e CPU PLL (VCO) frequency of operation for memory-to-CPU frequency multiplying. The PLL configurations for the MPC8240 is shown in Table 18.

Table 18. MPC8240 Microprocessor PLL Configurations

Ref. No.	PLL_CFG [0:4] <sup>2</sup>	CPU <sup>1</sup> HID1 [0:4]	200 MHz Part <sup>8,9</sup>			Ratios <sup>3,4</sup>	
			PCI Clock Input (PCI_SYNC_IN) Range (MHz)	Peripheral Logic/ Mem Bus Clock Range (MHz)	CPU Clock Range (MHz)	PCI-to-Mem (Mem VCO) Multiplier	Mem-to-CPU (CPU VCO) Multiplier
0	00000	00110	25–26	75–80	188–200	3 (6)	2.5 (5)
1	00001	11000	Not usable			3 (6)	3 (6)
2	00010	00101	50–56 <sup>5</sup>	50 – 56	100–112	1 (4)	2 (8)
3	00011	00101	Bypass			Bypass	2 (8)
4	00100	00101	25–28 <sup>5</sup>	50–56	100–113	2 (8)	2 (8)
5	00101	00110	Bypass			Bypass	2.5 (5)
7	00111	11000	Bypass			Bypass	3 (6)
8	01000	11000	33 <sup>6</sup> –56 <sup>5</sup>	33–56	100–168	1 (4)	3 (6)
A	01010	00111	Not usable			2 (4)	4.5 (9)
C	01100	00110	25–40	50–80	125–200	2 (4)	2.5 (5)
E	01110	11000	25–33	50–66	150–200	2 (4)	3 (6)
10	10000	00100	25–33	75–100	150–200	3 (6)	2 (4)
12	10010	00100	33 <sup>7</sup> –66	50–100	100–200	1.5 (3)	2 (4)
14	10100	11110	25–28	50–56	175–200	2 (4)	3.5 (7)
16	10110	11010	25	50	200	2 (4)	4 (8)
18	11000	11000	25–26	62–65	186–200	2.5 (5)	3 (6)
1A	11010	11010	50	50	200	1 (2)	4 (8)
1C	11100	11000	33 <sup>7</sup> –44	50–66	150–200	1.5 (3)	3 (6)
1D	11101	00110	33 <sup>7</sup> –53	50–80	125–200	1.5 (3)	2.5 (5)

Table 18. MPC8240 Microprocessor PLL Configurations (continued)

Ref. No.	PLL_CFG [0:4] <sup>2</sup>	CPU <sup>1</sup> HID1 [0:4]	200 MHz Part <sup>8,9</sup>			Ratios <sup>3,4</sup>	
			PCI Clock Input (PCI_SYNC_IN) Range (MHz)	Peripheral Logic/ Mem Bus Clock Range (MHz)	CPU Clock Range (MHz)	PCI-to-Mem (Mem VCO) Multiplier	Mem-to-CPU (CPU VCO) Multiplier
1E	11110	01111	Not usable			Off	Off
1F	11111	11111				Off	Off

**Notes:**

1. The processor HID1 values only represent the multiplier of the processor's PLL (memory-to-processor multiplier); thus, multiple MPC8240 PLL\_CFG[0:4] values may have the same processor HID1 value. This implies that system software cannot read the HID1 register and associate it with a unique PLL\_CFG[0:4] value.
2. PLL\_CFG[0:4] settings not listed (00110, 01001, 01011, 01101, 01111, 10001, 10011, 10101, 10111, 11001, and 11011) are reserved.
3. In PLL-bypass mode, the PCI\_SYNC\_IN input signal clocks the internal processor directly, the peripheral logic PLL is disabled, and the bus mode is set for 1:1 (PCI:Mem) mode operation. This mode is intended for hardware modeling support. The AC timing specifications given in this document do not apply in the PLL-bypass mode.
4. In clock-off mode, no clocking occurs inside the MPC8240 regardless of the PCI\_SYNC\_IN input.
5. Limited due to maximum memory VCO = 225 MHz.
6. Limited due to minimum CPU VCO = 200 MHz.
7. Limited due to minimum memory VCO = 100 MHz.
8. For clarity, range values are shown rounded down to the nearest whole number (decimal place accuracy removed).
9. Note that the 250-MHz part is available only in the XPC8240RZU $nnn$ x number series.

## 1.7 System Design Information

This section provides electrical and thermal design recommendations for successful application of the MPC8240.

### 1.7.1 PLL Power Supply Filtering

The AV<sub>DD</sub>, AV<sub>DD2</sub>, and LAV<sub>DD</sub> power signals on the MPC8240 provide power to the peripheral logic/memory bus PLL, MPC603e processor PLL, and SDRAM clock delay-locked loop (DLL), respectively. To ensure stability of the internal clocks, the power supplied to the AV<sub>DD</sub>, AV<sub>DD2</sub>, and LAV<sub>DD</sub> input signals should be filtered of any noise in the 500-KHz to 10-MHz resonant frequency range of the PLLs. Three separate circuits similar to the one shown in Figure 24 using surface mount capacitors with minimum effective series inductance (ESL) is recommended for AV<sub>DD</sub>, AV<sub>DD2</sub>, and LAV<sub>DD</sub> power signal pins. Consistent with the recommendations of Dr. Howard Johnson in *High Speed Digital Design: A Handbook of Black Magic* (Prentice Hall, 1993), using multiple small capacitors of equal value is recommended over using multiple values.

The circuits should be placed as close as possible to the respective input signal pins to minimize noise coupled from nearby circuits. Routing directly as possible from the capacitors to the input signal pins with minimal inductance of vias is important.

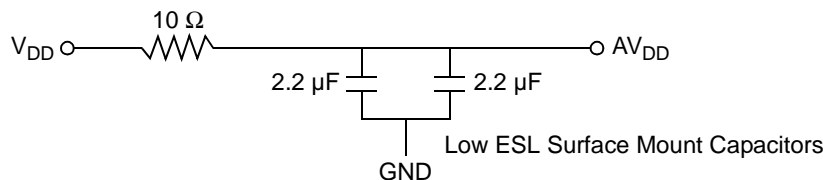


Figure 24. PLL Power Supply Filter Circuit

## 1.7.2 Power Supply Sizing

The power consumption numbers provided in Table 5 do not reflect power from the  $OV_{DD}$  and  $GV_{DD}$  power supplies that are non-negligible for the MPC8240. In typical application measurements, the  $OV_{DD}$  power ranged from 200 to 600 mW and the  $GV_{DD}$  power ranged from 300 to 900 mW. The ranges' low-end power numbers were results of the MPC8240 performing cache-resident integer operations at the slowest frequency combination of 33:66:166 (PCI:Mem:CPU) MHz. The  $OV_{DD}$  high-end range's value resulted from the MPC8240 performing continuous flushes of cache lines with alternating ones and zeros to PCI memory. The  $GV_{DD}$  high-end range's value resulted from the MPC8240 operating at the fastest frequency combination of 66:100:250 (PCI:Mem:CPU) MHz and performing continuous flushes of cache lines with alternating ones and zeros on 64-bit boundaries to local memory.

## 1.7.3 Decoupling Recommendations

Due to its dynamic power management feature, large address and data buses, and high operating frequencies, the MPC8240 can generate transient power surges and high frequency noise in its power supply, especially while driving large capacitive loads. This noise must be prevented from reaching other components in the MPC8240 system, and the MPC8240 itself requires a clean, tightly regulated source of power. Therefore, it is recommended that the system designer place at least one decoupling capacitor at each  $V_{DD}$ ,  $OV_{DD}$ ,  $GV_{DD}$ , and  $LV_{DD}$  pin of the MPC8240. It is also recommended that these decoupling capacitors receive their power from separate  $V_{DD}$ ,  $OV_{DD}$ ,  $GV_{DD}$ , and GND power planes in the PCB, utilizing short traces to minimize inductance. These capacitors should have a value of 0.1  $\mu\text{F}$ . Only ceramic SMT (surface mount technology) capacitors should be used to minimize lead inductance, preferably 0508 or 0603, oriented such that connections are made along the length of the part.

In addition, it is recommended that there be several bulk storage capacitors distributed around the PCB, feeding the  $V_{DD}$ ,  $OV_{DD}$ ,  $GV_{DD}$ , and  $LV_{DD}$  planes, to enable quick recharging of the smaller chip capacitors. These bulk capacitors should have a low ESR (equivalent series resistance) rating to ensure the quick response time necessary. They should also be connected to the power and ground planes through two vias to minimize inductance. Suggested bulk capacitors: 100–330  $\mu\text{F}$  (AVX TPS tantalum or Sanyo OSCON).

## 1.7.4 Connection Recommendations

To ensure reliable operation, it is highly recommended to connect unused inputs to an appropriate signal level. Unused active low inputs should be tied to  $OV_{DD}$ . Unused active high inputs should be connected to GND. All NC (no connect) signals must remain unconnected.

Power and ground connections must be made to all external  $V_{DD}$ ,  $OV_{DD}$ ,  $GV_{DD}$ ,  $LV_{DD}$ , and GND pins of the MPC8240.

The PCI\_SYNC\_OUT signal is intended to be routed halfway out to the PCI devices and then returned to the PCI\_SYNC\_IN input of the MPC8240.

The SDRAM\_SYNC\_OUT signal is intended to be routed halfway out to the SDRAM devices and then returned to the SDRAM\_SYNC\_IN input of the MPC8240. The trace length may be used to skew or adjust the timing window as needed. See the Motorola application note AN1794, “Backside L2 Timing Analysis for PCB Design Engineers,” for more information on this topic.

## 1.7.5 Pull-Up/Pull-Down Resistor Requirements

The data bus input receivers are normally turned off when no read operation is in progress; therefore, they do not require pull-up resistors on the bus. The data bus signals are: DH[0:31], DL[0:31], and PAR[0:7].

If the 32-bit data bus mode is selected, the input receivers of the unused data and parity bits ( $\overline{DL}$ [0:31] and  $\overline{PAR}$ [4:7]) will be disabled, and their outputs will drive logic zeros when they would otherwise normally be driven. For this mode, these pins do not require pull-up resistors and should be left unconnected by the system to minimize possible output switching.

The  $\overline{TEST0}$  pins require pull-up resistors of 120  $\Omega$  or less connected to  $OV_{DD}$ .

It is recommended that  $\overline{TEST2}$  have a weak pull-up resistor (2–10 k $\Omega$ ) connected to  $GV_{DD}$ .

It is recommended that the following signals be pulled up to  $OV_{DD}$  with weak pull-up resistors (2–10 k $\Omega$ ): SDA, SCL, SMI, SRESET, TBEN,  $\overline{CHKSTOP\_IN}$ , and  $\overline{TEST1}$ .

It is recommended that the following PCI control signals be pulled up to  $LV_{DD}$  with weak pull-up resistors (2–10 k $\Omega$ ):  $\overline{DEVSEL}$ ,  $\overline{FRAME}$ ,  $\overline{IRDY}$ ,  $\overline{LOCK}$ ,  $\overline{PERR}$ ,  $\overline{SERR}$ ,  $\overline{STOP}$ ,  $\overline{TRDY}$ , and  $\overline{INTA}$ . The resistor values may need to be adjusted stronger to reduce induced noise on specific board designs.

The following pins have internal pull-up resistors enabled at all times:  $\overline{REQ}$ [0:3],  $\overline{REQ4/DA4}$ , TCK, TDI, TMS, and  $\overline{TRST}$ . See Table 17 for more information.

The following pins have internal pull-up resistors enabled only while the MPC8240 is in the reset state:  $\overline{GNT4/DA5}$ ,  $\overline{DL0}$ ,  $\overline{FOE}$ ,  $\overline{RCS0}$ ,  $\overline{SDRAS}$ ,  $\overline{SDCAS}$ ,  $\overline{CKE}$ ,  $\overline{AS}$ ,  $\overline{MCP}$ ,  $\overline{MAA}$ [0:2],  $\overline{PMAA}$ [0:2], and  $\overline{QACK/DA0}$ . See Table 17 for more information.

The following pins are reset configuration pins:  $\overline{GNT4/DA5}$ ,  $\overline{DL0}$ ,  $\overline{FOE}$ ,  $\overline{RCS0}$ ,  $\overline{CKE}$ ,  $\overline{AS}$ ,  $\overline{MCP}$ ,  $\overline{QACK/DA0}$ ,  $\overline{MAA}$ [0:2],  $\overline{PMAA}$ [0:2], and  $\overline{PLL\_CFG}$ [0:4]/ $\overline{DA}$ [10:6]. These pins are sampled during reset to configure the device.

Reset configuration pins should be tied to GND via 1-k $\Omega$  pull-down resistors to ensure a logic 0 level is read into the configuration bits during reset if the default logic 1 level is not desired.

Any other unused active-low input pins should be tied to a logic one level through weak pull-up resistors (2–10 k $\Omega$ ) to the appropriate power supply. Unused active-high input pins should be tied to GND through weak pull-down resistors (2–10 k $\Omega$ ).

## 1.7.6 JTAG Configuration Signals

Boundary scan testing is enabled through the JTAG interface signals. The  $\overline{TRST}$  signal is optional in the IEEE 1149.1 specification but is provided on all processors that implement the PowerPC architecture. While it is possible to force the TAP controller to the reset state using only the TCK and TMS signals, more reliable power-on reset performance will be obtained if the  $\overline{TRST}$  signal is asserted during power-on reset. Because the JTAG interface is also used for accessing the common on-chip processor (COP) function, simply tying  $\overline{TRST}$  to  $\overline{HRESET}$  is not practical.

The COP function of these processors allows a remote computer system (typically, a PC with dedicated hardware and debugging software) to access and control the internal operations of the processor. The COP

interface connects primarily through the JTAG port of the processor, with some additional status monitoring signals. The COP port requires the ability to independently assert  $\overline{\text{HRESET}}$  or  $\overline{\text{TRST}}$  in order to fully control the processor. If the target system has independent reset sources, such as voltage monitors, watchdog timers, power supply failures, or push-button switches, the COP reset signals must be merged into these signals with logic.

The arrangement shown in Figure 25 allows the COP to independently assert  $\overline{\text{HRESET}}$  or  $\overline{\text{TRST}}$ , while ensuring that the target can drive  $\overline{\text{HRESET}}$  as well. If the JTAG interface and COP header will not be used,  $\overline{\text{TRST}}$  should be tied to  $\overline{\text{HRESET}}$  so that it is asserted when the system reset signal ( $\overline{\text{HRESET}}$ ) is asserted ensuring that the JTAG scan chain is initialized during power-on.

The COP header shown in Figure 25 adds many benefits—breakpoints, watchpoints, register and memory examination/modification, and other standard debugger features are possible through this interface—and can be as inexpensive as an unpopulated footprint for a header to be added when needed.

The COP interface has a standard header for connection to the target system, based on the 0.025" square-post, 0.100" centered header assembly (often called a Berg header).

There is no standardized way to number the COP header shown in Figure 25; consequently, many different pin numbers have been observed from emulator vendors. Some are numbered top-to-bottom then left-to-right, while others use left-to-right then top-to-bottom, while still others number the pins counter clockwise from pin 1 (as with an IC). Regardless of the numbering, the signal placement recommended in Figure 25 is common to all known emulators.

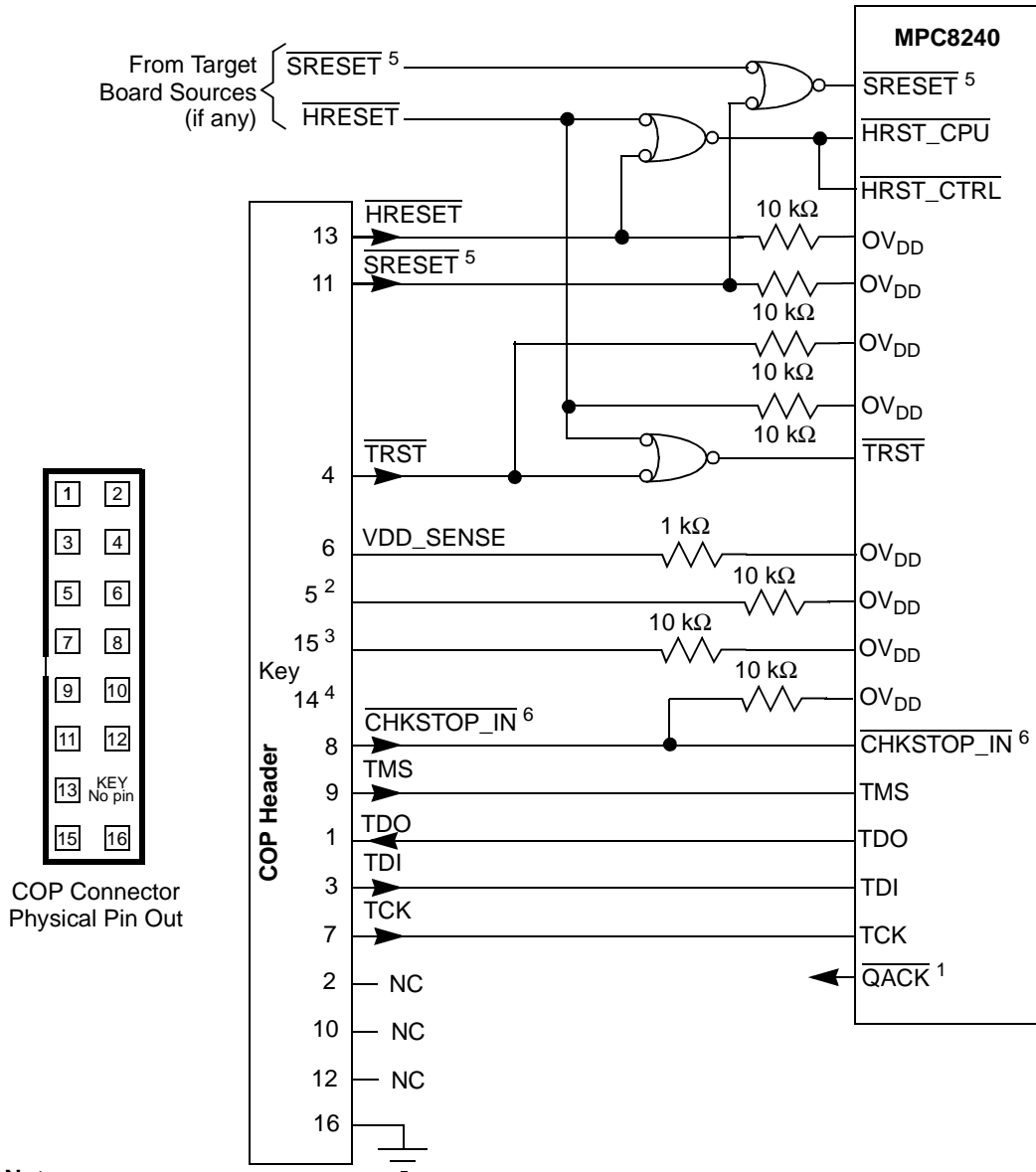


Figure 25. COP Connector Diagram

### 1.7.7 PCI Reference Voltage—LV<sub>DD</sub>

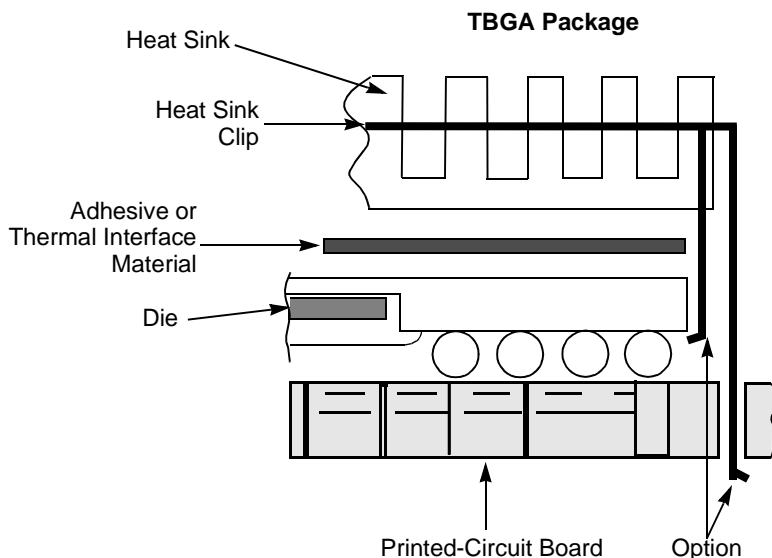
The MPC8240 PCI reference voltage (LV<sub>DD</sub>) pins should be connected to 3.3 ±0.3 V power supply if interfacing the MPC8240 into a 3.3-V PCI bus system. Similarly, the LV<sub>DD</sub> pins should be connected to 5.0 ±5% V power supply if interfacing the MPC8240 into a 5-V PCI bus system. For either reference



voltage, the MPC8240 always performs 3.3-V signaling as described in the *PCI Local Bus Specification*, (Rev 2.1). The MPC8240 only tolerates 5-V signals when interfaced into a 5-V PCI bus system.

## 1.7.8 Thermal Management Information

This section provides thermal management information for the tape ball grid array (TBGA) package for air-cooled applications. Proper thermal control design is primarily dependent on the system-level design—the heat sink, airflow, and thermal interface material. To reduce the die-junction temperature, heat sinks may be attached to the package by several methods: adhesive, spring clip to holes in the printed-circuit board, or package and mounting clip and screw assembly. See Figure 26.



**Figure 26. Package Exploded Cross-Sectional View with Several Heat Sink Options**

Figure 27 depicts the die junction-to-ambient thermal resistance for four typical cases:

- A heat sink is not attached to the TBGA package, and there exists high board-level thermal loading of adjacent components.
- A heat sink is not attached to the TBGA package, and there exists low board-level thermal loading of adjacent components.
- A heat sink (for example, ChipCoolers #HTS255-P) is attached to the TBGA package, and there exists high board-level thermal loading of adjacent components.
- A heat sink (for example, ChipCoolers #HTS255-P) is attached to the TBGA package, and there exists low board-level thermal loading of adjacent components.



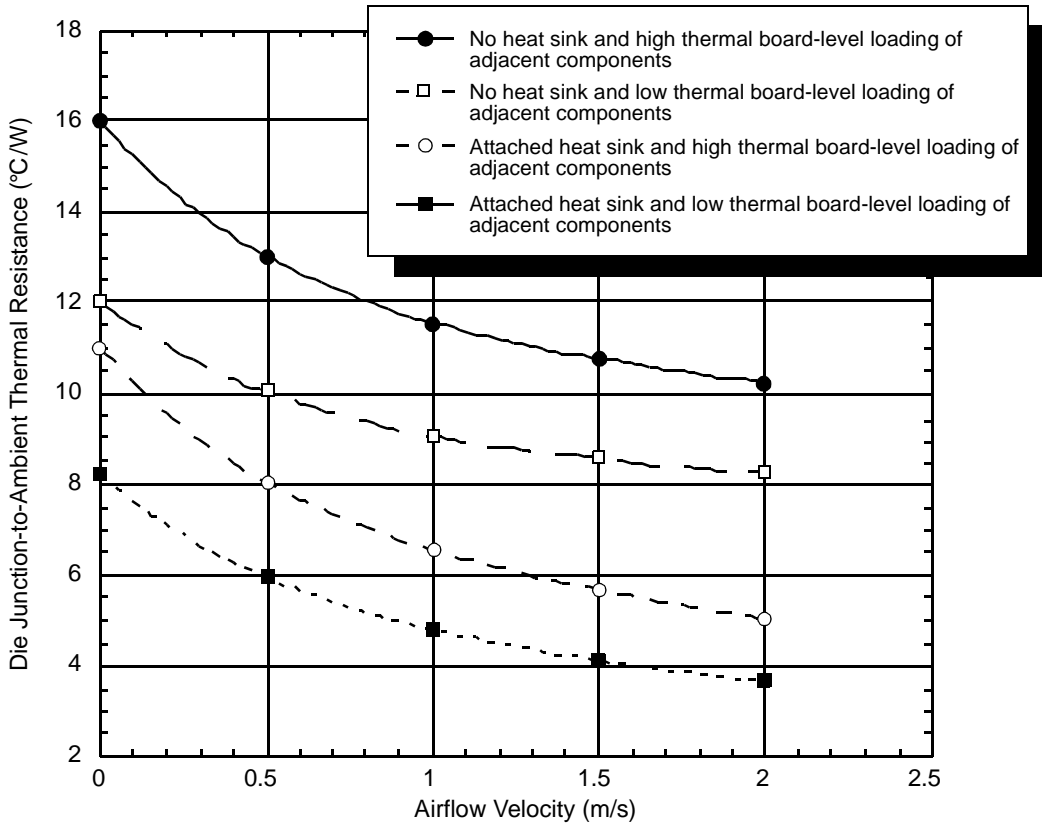


Figure 27. Die Junction-to-Ambient Resistance

The board designer can choose between several types of heat sinks to place on the MPC8240. Several commercially-available heat sinks for the MPC8240 are provided by the following vendors:

- |  |              |
|--|--------------|
| Aavid Thermalloy<br>80 Commercial St.<br>Concord, NH 03301<br>Internet: <a href="http://www.aavidthermalloy.com">www.aavidthermalloy.com</a>                         | 603-224-9988 |
| Alpha Novatech<br>473 Sapena Ct. #15<br>Santa Clara, CA 95054<br>Internet: <a href="http://www.alphanovatech.com">www.alphanovatech.com</a>                          | 408-749-7601 |
| The Bergquist Company<br>18930 West 78 <sup>th</sup> St.<br>Chanhassen, MN 55317<br>Internet: <a href="http://www.bergquistcompany.com">www.bergquistcompany.com</a> | 800-347-4572 |
| International Electronic Research Corporation (IERC)<br>413 North Moss St.<br>Burbank, CA 91502<br>Internet: <a href="http://www.ctscorp.com">www.ctscorp.com</a>    | 818-842-7277 |

Tyco Electronics  
Chip Coolers™  
P.O. Box 3668  
Harrisburg, PA 17105-3668  
Internet: [www.chipcoolers.com](http://www.chipcoolers.com)

800-522-6752

Wakefield Engineering  
33 Bridge St.  
Pelham, NH 03076  
Internet: [www.wakefield.com](http://www.wakefield.com)

603-635-5102

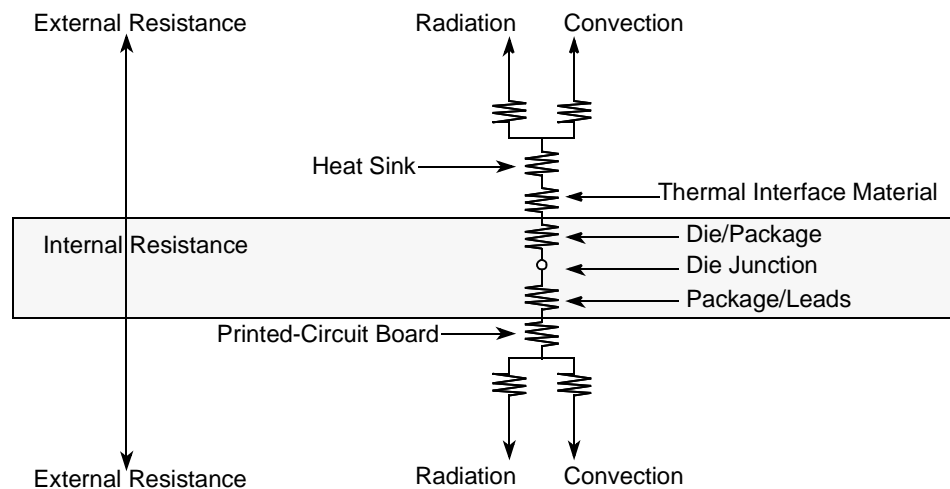
Ultimately, the final selection of an appropriate heat sink depends on many factors, such as thermal performance at a given air velocity, spatial volume, mass, attachment method, assembly, and cost.

### 1.7.8.1 Internal Package Conduction Resistance

The intrinsic conduction thermal resistance paths for the TBGA, cavity-down, packaging technology shown in Figure 26 are as follows:

- The die junction-to-case thermal resistance
- The die junction-to-ball thermal resistance

Figure 28 depicts the primary heat transfer path for a package with an attached heat sink mounted to a printed-circuit board.



(Note the internal versus external package resistance.)

**Figure 28. TBGA Package with Heat Sink Mounted to a Printed-Circuit Board**

For this cavity-down, wire-bond TBGA package, heat generated on the active side of the chip is conducted through the silicon, die attach, and package spreader, through the heat sink attach material (or thermal interface material), and finally to the heat sink, where it is removed by forced-air convection.

### 1.7.8.2 Adhesives and Thermal Interface Materials

A thermal interface material is recommended at the package lid-to-heat sink interface to minimize thermal contact resistance. For those applications where the heat sink is attached by a spring clip mechanism, Figure 29 shows the thermal performance of three thin-sheet thermal-interface materials (silicone,

graphite/oil, fluoroether oil), a bare joint, and a joint with thermal grease as a function of contact pressure. As shown, the performance of these thermal interface materials improves with increased contact pressure. The use of thermal grease significantly reduces the interface thermal resistance, that is, the bare joint results in a thermal resistance approximately seven times greater than that of the thermal grease joint.

Heat sinks are attached to the package by means of a spring clip to holes in the printed-circuit board (see Figure 26). Therefore, the synthetic grease offers the best thermal performance, considering the low interface pressure. Of course, the selection of any thermal interface material depends on many factors: thermal performance requirements, manufacturability, service temperature, dielectric properties, cost, and so on.

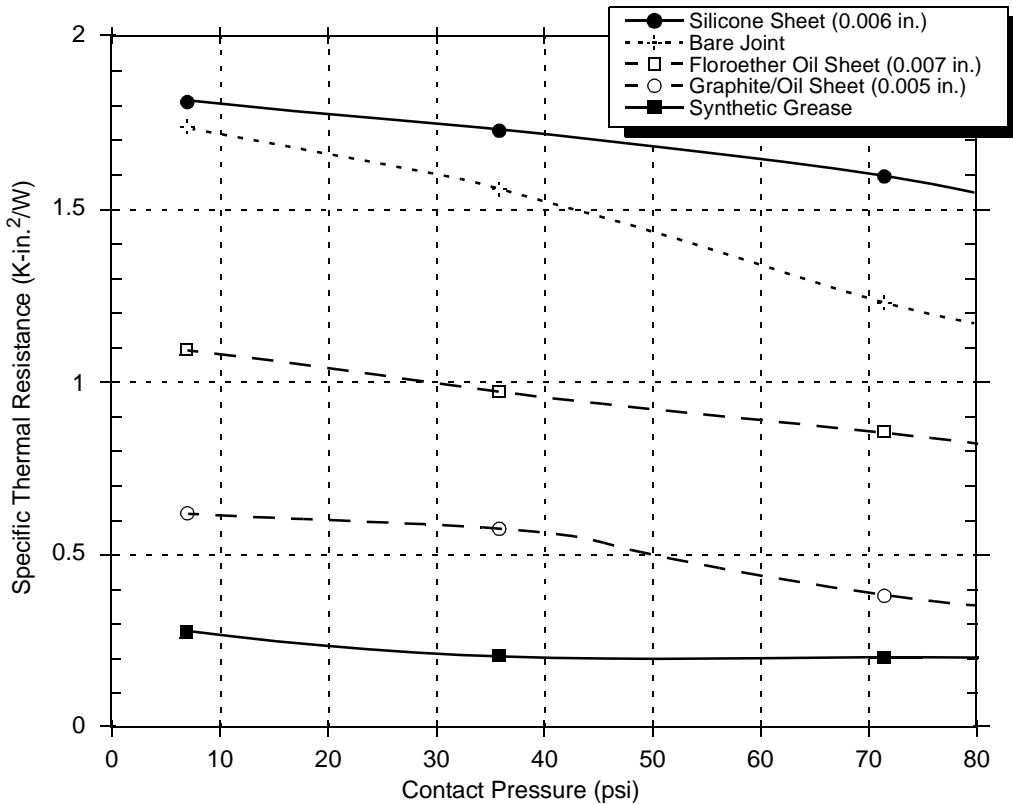


Figure 29. Thermal Performance of Select Thermal Interface Material

The board designer can choose between several types of thermal interfaces. Heat sink adhesive materials should be selected based on high conductivity and yet adequate mechanical strength to meet equipment shock/vibration requirements. The following vendors provide several commercially-available thermal interfaces and adhesive materials:

- |   |              |
|---|--------------|
| Chomerics, Inc.<br>77 Dragon Ct.<br>Woburn, MA 01888-4014<br>Internet: <a href="http://www.chomerics.com">www.chomerics.com</a>   | 781-935-4850 |
| Dow-Corning Corporation<br>Dow-Corning Electronic Materials<br>2200 W. Salzburg Rd.<br>Midland, MI 48686-0997<br>Internet: <a href="http://www.dow.com">www.dow.com</a> | 800-248-2481 |

Shin-Etsu MicroSi, Inc.  
 10028 S. 51st St.  
 Phoenix, AZ 85044  
 Internet: www.microsi.com

888-642-7674

Thermagon Inc.  
 4707 Detroit Ave.  
 Cleveland, OH 44102  
 Internet: www.thermagon.com

888-246-9050

The following section provides a heat sink selection example using one of the commercially-available heat sinks.

### 1.7.8.3 Heat Sink Selection Example

For preliminary heat sink sizing, the die-junction temperature,  $T_J$ , can be expressed as follows:

$$T_J = T_A + T_R + (R_{\theta JC} + R_{\theta INT} + R_{\theta SA}) \times P_D$$

where

$T_J$  is the die-junction temperature

$T_A$  is the inlet cabinet ambient temperature

$T_R$  is the air temperature rise within the computer cabinet

$R_{\theta JC}$  is the junction-to-case thermal resistance

$R_{\theta INT}$  is the adhesive or interface material thermal resistance

$R_{\theta SA}$  is the heat sink base-to-ambient thermal resistance

$P_D$  is the power dissipated by the device

During operation, the die-junction temperatures ( $T_J$ ) should be maintained at less than the value specified in Table 2. The temperature of the air cooling the component greatly depends on the ambient inlet air temperature and the air temperature rise within the electronic cabinet. An electronic cabinet inlet-air temperature ( $T_A$ ) may range from 30° to 40°C. The air temperature rise within a cabinet ( $T_R$ ) may be in the range of 5° to 10°C. The thermal resistance of the thermal interface material ( $R_{\theta INT}$ ) is typically about 1°C/W. Assuming a  $T_A$  of 30°C, a  $T_R$  of 5°C, a TBGA package  $R_{\theta JC} = 1.8$ , and a power consumption ( $P_D$ ) of 5.0 watts, the following expression for  $T_J$  is obtained for die-junction temperature:

$$T_J = 30^\circ\text{C} + 5^\circ\text{C} + (1.8^\circ\text{C/W} + 1.0^\circ\text{C/W} + R_{\theta SA}) \times 5.0 \text{ W}$$

For preliminary heat sink sizing, the heat sink base-to-ambient thermal resistance is needed from the heat sink manufacturer.

Though the die junction-to-ambient and the heat sink-to-ambient thermal resistances are a common figure of merit used for comparing the thermal performance of various microelectronic packaging technologies, one should exercise caution when using only this metric in determining thermal management because no single parameter can adequately describe three-dimensional heat flow. The final die-junction operating temperature is not only a function of the component-level thermal resistance, but the system-level design and its operating conditions. In addition to the component's power consumption, a number of factors affect the final operating die-junction temperature: airflow, board population (local heat flux of adjacent components), heat sink efficiency, heat sink attach, heat sink placement, next-level interconnect technology, system air temperature rise, altitude, and so on.

Due to the complexity and the many variations of system-level boundary conditions for today's microelectronic equipment, the combined effects of the heat transfer mechanisms (radiation, convection,

and conduction) may vary widely. For these reasons, it is recommended that conjugate heat-transfer models for the board, as well as system-level designs, be used.

## 1.8 Document Revision History

Table 19 provides a revision history for this hardware specification.

**Table 19. Document Revision History**

Revision Number	Substantive Change(s)
0	Preliminary release with some TBDs in the spec tables.
0.1	Updated notes for Table 2. Replaced TBDs in Table 3 with values for output high and low voltages. Deleted 25/25/75 column from Table 5; inconsistent with PLL encoding 01000. Updated minimum processor frequencies in Table 6 from 80 to 100 MHz. Updated values in Table 8. Spec 10b split for flow through and registered modes. Updated values in Table 9. Updated PCI_HOLD_DEL value guidelines in Table 10 and Figure 10. Relabeled DA[0:15] pins in opposite order and added Note 11 for TEST2 in Table 17. Changed PLL configurations 01001 and 10001 in Table 18 to reserved configurations. Updated PLL configuration 00010's operation ranges in Table 18. Revised TRST connection recommendations in Figure 22 for COP interface.
0.2	Added Note 4 to Table 2, updated Note and Caution numbers in Table 2 and Figure 2. Modified Table 6: —Added 250 MHz column. —Changed Maximum PCI Input Frequency for 200 MHz part from 33 to 66 MHz. —Made one column common entries for Memory Bus and PCI Input Frequencies. Revised Note 7 of Table 7 to indicate a feedback loop length of 6.25 inches (formerly 11.8 inches) corresponding to approximately 1 ns of delay. Added 250 MHz column to Table 18. Corrected document revision number for previous version of this document in Table 19. Document revision was indicated as 1, should have been 0.1. Removed P = Reduced Spec information from Figure 28; does not apply to MPC8240. Added R = Modified Voltage Spec information to Figure 28.

### Table 19. Document Revision History (continued)

Revision Number	Substantive Change(s)
0.3	<p>Removed "PowerPC Platform compliant" from first sentence on cover sheet.</p> <p>Changed PCI 2.1—"compatible" to "compliant" in Section 1.2.</p> <p>Updated Table 5 and its notes with preliminary power-consumption information.</p> <p>Updated Table 6, removing 266 MHz frequency information.</p> <p>Made corrections to Table 7.</p> <ul style="list-style-type: none"> <li>• Items 5a and 5b were changed to correct values for 66-MHz PCI_SYNC_IN.</li> <li>• OSC_IN Frequency Stability spec from 1000 to 100 ppm.</li> </ul> <p>Table 9:</p> <ul style="list-style-type: none"> <li>• Changed item 12b1 from 8.0 to 7.0 ns.</li> <li>• Added item 12b3, Output Valid for ROM accesses.</li> </ul> <p>Table 11, item 2, "KAHLUA" terminology replaced with MPC8240.</p> <p>Added EPIC Serial Interrupt Timing Section with two new figures, causing cross-references to subsequent figures to be updated.</p> <p>Updated formatting of pin out in Table 17.</p> <p>Modified notes section in Table 17:</p> <ul style="list-style-type: none"> <li>• Split Note 3 into new Notes 3 and 12. Notes 3, 5, and 7 cover internal pull-up resistors active only during the reset state. Note 12 covers internal pull-up resistors enabled at all times.</li> <li>• Note 11 has been revised.</li> <li>• Added Note 10 to <u>SDA</u> and <u>SCL</u> signals for consistency with the MPC8240 User's Manual.</li> <li>• Added Note 10 to <u>SMI</u> and <u>TBEN</u>; inputs that should have pull-ups and for consistency with reference designs.</li> <li>• Added Note 10 to <u>SRESET</u> and <u>CHKSTOP_IN</u> for consistency with Figure 23 (COP Connector)</li> <li>• Added Notes 13 and 14 for output valid specifications dependent upon memory mode.</li> <li>• Added Note 15 for pins affected by programmable PCI output valid and hold time.</li> <li>• Added Notes 16 –18 relating to open drain pins.</li> </ul> <p>Figure 18:</p> <ul style="list-style-type: none"> <li>• Revised 200-MHz column to reflect PCI_SYNC_IN 66-MHz upper limit.</li> <li>• Refs 1E and 1F not usable entries made to match others in the table.</li> <li>• Revised Notes 4 and 5 changing OSC_IN to PCI_SYNC_IN.</li> <li>• Removed 266-MHz column.</li> <li>• Removed Ref 0x06 for dual PLL bypass mode; added it to reserved list in Note 3.</li> <li>• Revised Note 4 describing PLL bypass mode.</li> </ul> <p>Added missing cross-reference in Section 1.7.2 and corrected Schottky reference to the 1N5820 diodes.</p> <p>Added Section 1.7.2 on power supply sizing.</p> <p>Modified internal pull-up resistor list in Section 1.7.5 to be consistent with Notes of Table 17; added reset configuration pin pull-down resistor value recommendation.</p> <p>Modified Figure 23, COP connector diagram:</p> <ul style="list-style-type: none"> <li>• Reversed direction of <u>CKSTP_IN</u> arrow to show it going in.</li> <li>• Added a pull-up resistor on <u>TRST</u>.</li> </ul> <p>Changed R-spec device's V<sub>DD</sub> range from 2.5–2.625 V to 2.5–2.75 V.</p>
0.4	<p>Modified DLL Lock Range with DLL_EXTEND = 1 equation in Table 7 from <math>0 \leq (NT_{clk}/2 - t_{loop} - t_{fix0}) \leq 7</math> to <math>0 \leq (NT_{clk} - T_{clk}/2 - t_{loop} - t_{fix0}) \leq 7</math>.</p> <p>Modified Figure 5 to only show T<sub>loop</sub> up to 15 ns, not practical to implement T<sub>loop</sub> beyond 15 ns.</p> <p>Modified DL[0:31] and DH[0:31] signal names to MDL[0:31] and MDH[0:31], respectively, in Table 17 to be consistent with the Tundra Tsi107™ PowerPC host bridge data bus naming convention.</p> <p>Several active low signal names in Table 17 inadvertently had the overline formatting removed during the final edit process of the previous revision. The signals are shown correctly with overlines in this version. Signals affected were: <u>DEVSEL</u>, <u>FRAME</u>, <u>LOCK</u>, <u>PERR</u>, <u>SERR</u>, <u>STOP</u>, <u>TRDY</u>, <u>INTA</u>, <u>FOE</u>, <u>RCS0</u>, <u>RCS1</u>, <u>SDRAS</u>, <u>SDCAS</u>, <u>WE</u>, <u>AS</u>, <u>HRST_CTRL</u>, <u>HRST_CPU</u>, <u>MCP</u>, <u>SMI</u>, <u>SRESET</u>, <u>CHKSTOP_IN</u>, and <u>MIV</u>.</p>

**Table 19. Document Revision History (continued)**

Revision Number	Substantive Change(s)
0.5	<p>Removed references to <math>GV_{DD} = 2.5\text{ V}</math> until characterization of the memory interface at this voltage has been completed.</p> <p>Corrected Figure 2 power supply ramp-up time to be before the 100 ms PLL relock time.</p> <p>Table 3:</p> <ul style="list-style-type: none"> <li>• Deleted input leakage specification @ <math>LV_{DD} = 5.5\text{ V}</math>.</li> <li>• Changed minimum 'Input High Voltage for PCI only' from <math>0.5 \cdot OV_{DodoD}</math> to <math>0.65 \cdot OV_{DD}</math> and added Note 6.</li> <li>• Changed condition on 'Input Low Voltage,' <math>V_{IL}</math>, from 'All inputs except OSC_IN' to 'All inputs except PCI_SYNC_IN.'</li> <li>• Replaced minimum <math>CV_{IH}</math> formula, <math>0.5 \cdot OV_{DD}</math>, with 2.4-V value.</li> <li>• Replaced maximum <math>CV_{IL}</math> formula, <math>0.3 \cdot OV_{DD}</math>, with 0.4-V value.</li> </ul> <p>Added Note 10 to Table 5.</p> <p>Changed minimum memory bus frequency of operation from 25 to 33 MHz in Table 6 to coincide with information shown in PLL_CFG Table 18.</p> <p>Updated clock specifications in Table 7.</p> <p>Updated input AC timing specifications in Table 8.</p> <p>Updated output AC timing specifications in Table 9.</p> <p>Replaced TBDs in Table 14 for specs 3, 5, and 6.</p> <p>Table 17 renamed TEST3 (pin AF20) to TRIG_IN and renamed TEST4 (pin AC18) to TRIG_OUT; moved both pins from Test/Configuration Signals group to Miscellaneous Signals group.</p> <p>Added external pull-up resistor to LVDD recommendation for <math>\overline{INTA}</math> signal in Table 17 and Section 1.7.5.</p> <p>Added Note 19 to Table 17 about AVDD and LAVDD being internally connected; revised Section 1.7.1, on filtering these pins.</p> <p>Replaced HID1 column TBDs in Table 18 and deleted Note 1 resulting in renumbering notes throughout Table 18.</p> <p>Added Section 1.7.7, about PCI reference voltage.</p> <p>Added note in Section 1.9, indicating 'L=Standard Spec.' part is only available in 200 MHz version of the device. Changed 'XPC' to 'MPC' for consistency with other references in the document.</p>

Freescale Semiconductor, Inc.



**Table 19. Document Revision History (continued)**

Revision Number	Substantive Change(s)
0.6	<p>Updated Technology in Section 1.3 from 0.32 to 0.29 <math>\mu\text{m}</math>.</p> <p>Updated Notes in Table 2. Changed line 2 to reflect supply voltage wording of the other lines. Changed notes 2 and 3 to include all LVDD input tolerant signals.</p> <p>Updated Table 4 eliminating LVDD = 5.0 V entries for DRV_PCI. Changed LVDD to OVDD for remaining DRV_PCI entries. Updated notes.</p> <p>Updated Table 6 to show minimum memory bus operating frequency is 33 MHz.</p> <p>Updated Table 8 with new characterization data for numbers 22 and 23.</p> <p>Updated Table 8 adding 'In-line' to 'Registered' in Spec 10b2.</p> <p>Updated Table 9 to Table 10 to how changes for <math>\overline{\text{MCP}}</math> and CKE reset configuration changes for PCI_HOLD_DEL.</p> <p>Updated Table 12 eliminating 25 MHz column since memory interface does not operate at this frequency.</p> <p>Updated Table 17:</p> <ul style="list-style-type: none"> <li>• REQ4/DA4 and PLL_CFG[0:4]/DA[10:6] changed Pin Type from Input to I/O.</li> <li>• DA2, DA[11:13], DA[14:15] changed Pin Type from I/O to Output.</li> <li>• Reversed vector ordering for the PCI Interface Signals: <math>\overline{\text{C/BE}}[0:3]</math> changed to <math>\overline{\text{C/BE}}[3:0]</math>, AD[0:31] changed to AD[31:0], <math>\overline{\text{GNT}}[0:3]</math> changed to <math>\overline{\text{GNT}}[3:0]</math>, and <math>\overline{\text{REQ}}[0:3]</math> changed to REQ[3:0]. The package pin number orderings were also reversed meaning that pin functionality did NOT change. For example, AD0 is still on signal C22, AD1 is still on signal D22, ... AD31 is still on signal V25. This change was made to make the vectored PCI signals in the MPC8240 Hardware Specification consistent with the PCI Local Bus Specification and the MPC8240 User Manual vector ordering.</li> <li>• Deleted Note 19 indicating LAVDD and AVDD are internally connected. Added a new Note 19 about OSC_IN and EPIC control signals input voltage levels.</li> </ul> <p>Updated Section 1.7.1, eliminating references to LAVDD and AVDD being internally connected.</p> <p>Updated Table 23 changing 2-k<math>\Omega</math> pull-up resistor on VDD_SENSE to 1-k<math>\Omega</math>.</p> <p>Moved Section 1.7.7 to be at end of JTAG section.</p> <p>Changed erroneous C4 reference in Figure 26 title to TBGA.</p> <p>Deleted references to FLOTHERM models in Section 1.7.8.3.</p>
1	<p>Updated notes for Table 2, to include that the values maybe exceeded for up to 20 ms.</p> <p>Updated Figure 2, removed note 2 concerning voltage sequencing.</p> <p>Updated Solder Balls in Section 1.5.1, from 63/37 Sn/Pb to 62 Sn/36 Pb/2 Ag.</p> <p>Updated Table 9, adding 'address' to 12b1-3.</p> <p>Updated Table 10 to show the settings for silicon rev. 1.0/1.1 and for silicon rev. 1.2/1.3.</p> <p>Updated Table 17:</p> <ul style="list-style-type: none"> <li>• removed Note 10 from TRIG_OUT.</li> <li>• Created separate rows for <math>\overline{\text{TEST0}}</math> and <math>\overline{\text{TEST1}}</math> to reflect the change made in Note 1</li> <li>• Changed Note 1 to refer only to <math>\overline{\text{TEST0}}</math>.</li> </ul> <p>Removed Section 1.7.2.</p> <p>Section 1.6.8—Updated list of heat sink and thermal interface vendors.</p> <p>Changed format of Section 1.8.</p>
2	<p>Section 1.3.1.5—Updated Table 5 to reflect power numbers for the L spec (2.5 V) part. The power numbers for the R spec (2.625 V) part are now in the part number specifications document MPC8240RZUPNS.</p> <p>Section 1.5—Table 18 now reflects the L spec parts (200 MHz). The R spec PLL table is now in the R spec (250 MHz) part number specifications document MPC8240RZUPNS.</p> <p>Section 1.6.6—Updated this section and Figure 26.</p> <p>Section 1.8.2—Updated reference to part number specifications document.</p>



Table 19. Document Revision History (continued)

Revision Number	Substantive Change(s)
3	Throughout this document, the acronym EPIC was changed to PIC. Throughout this document, the register name EICR was changed to ICR Figure 2—The note numbers in the figure were renumbered to reflect the notes. Table 7—Num 15 and 16 were updated, and Note 7 was corrected. Figure 5 was updated to reflect the changes made in Table 7. Section 1.7.6—Updated this section and Figure 23. Section 1.9.1—Updated Table 20. Section 1.9.2—Updated Table 21.
4	Section 1.4.1.2—Added Figure 4 and 5, Overshoot and Undershoot Voltage of PCI Interface Section 1.5.1—Added solder ball package information for Lead free TBGA offering Section 1.9—Added information regarding Lead free TBGA offering.

## 1.9 Ordering Information

Ordering information for the parts fully covered by this specification document is provided in Section 1.9.1, “Part Numbers Fully Addressed by This Document.” Section 1.9.2, “Part Numbers Not Fully Addressed by This Document,” lists the part numbers that do not fully conform to the specifications of this document. These special part numbers require an additional document called a part number specification.

### 1.9.1 Part Numbers Fully Addressed by This Document

Table 20 provides the Motorola part numbering nomenclature for the MPC8240. Note that the individual part numbers correspond to a maximum processor core frequency. For available frequencies, contact a local Motorola sales office. Each part number also contains a revision code that refers to the die mask revision number. The revision level can be determined by reading the Revision ID register at address offset 0x08.

Table 20. Part Numbering Nomenclature

<b>XPC</b>	<b>nnnn</b>	<b>x</b>	<b>xx</b>	<b>nnn</b>	<b>x</b>
Product Code	Part Identifier	Process Descriptor	Package <sup>1</sup>	Processor Frequency <sup>2</sup>	Revision Level
XPC	8240	L = 2.5 V ± 125 mV 0 to 105°C	ZU = TBGA V V = Lead free TBGA	200	E: 1.3, Revision ID 0x13

#### Notes:

- See Section 1.5, “Package Description,” for more information on available package types.
- Processor core frequencies supported by parts addressed by this specification only. Not all parts described in this specification support all core frequencies. Additionally, parts addressed by part number specifications may support other maximum core frequencies.

### 1.9.2 Part Numbers Not Fully Addressed by This Document

Parts with application modifiers or revision levels not fully addressed in this specification document are described in separate part number specifications that supplement and supersede this document. Table 21 shows the part numbers addressed by the XPC8240RXX250x part number specifications.

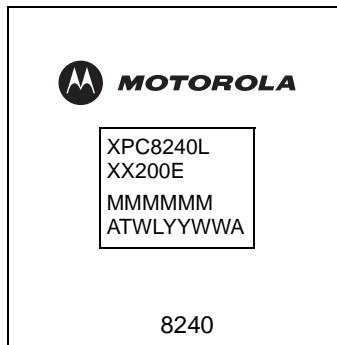
Table 21. Part Numbers Addressed by XPC8240RXX250x Part Number Specification

<b>XPC</b>	<b>nnnn</b>	<b>x</b>	<b>xx</b>	<b>nnn</b>	<b>x</b>
Product Code	Part Identifier	Process Descriptor	Package	Processor Frequency	Revision Level
XPC	8240	R = 2.625 V ± 125 mV, 0 to 105°C	ZU = TBGA V V = Lead free TBGA	250	E: 1.3; Revision ID 0x13

**Note:** For other differences, see applicable specifications.

### 1.9.3 Part Marking

Parts are marked as the example shown in Figure 30.



TBGA

**Notes:**

- MMMMMM is the 6-digit mask number.
- ATWLYYWWA is the traceability code.

**Figure 30. Motorola Part Marking for TBGA Device**

THIS PAGE INTENTIONALLY LEFT BLANK

# Freescale Semiconductor, Inc.

## HOW TO REACH US:

### USA/EUROPE/LOCATIONS NOT LISTED:

Motorola Literature Distribution  
P.O. Box 5405, Denver, Colorado 80217  
1-480-768-2130  
(800) 521-6274

### JAPAN:

Motorola Japan Ltd.  
SPS, Technical Information Center  
3-20-1, Minami-Azabu Minato-ku  
Tokyo 106-8573 Japan  
81-3-3440-3569

### ASIA/PACIFIC:

Motorola Semiconductors H.K. Ltd.  
Silicon Harbour Centre, 2 Dai King Street  
Tai Po Industrial Estate, Tai Po, N.T., Hong Kong  
852-26668334

### TECHNICAL INFORMATION CENTER:

(800) 521-6274

### HOME PAGE:

[www.motorola.com/semiconductors](http://www.motorola.com/semiconductors)

Information in this document is provided solely to enable system and software implementers to use Motorola products. There are no express or implied copyright licenses granted hereunder to design or fabricate any integrated circuits or integrated circuits based on the information in this document.

Motorola reserves the right to make changes without further notice to any products herein.

Motorola makes no warranty, representation or guarantee regarding the suitability of its products for any particular purpose, nor does Motorola assume any liability arising out of the application or use of any product or circuit, and specifically disclaims any and all liability, including without limitation consequential or incidental damages. "Typical" parameters which may be provided in Motorola data sheets and/or specifications can and do vary in different applications and actual performance may vary over time. All operating parameters, including "Typicals" must be validated for each customer application by customer's technical experts. Motorola does not convey any license under its patent rights nor the rights of others. Motorola products are not designed, intended, or authorized for use as components in systems intended for surgical implant into the body, or other applications intended to support or sustain life, or for any other application in which the failure of the Motorola product could create a situation where personal injury or death may occur. Should Buyer purchase or use Motorola products for any such unintended or unauthorized application, Buyer shall indemnify and hold Motorola and its officers, employees, subsidiaries, affiliates, and distributors harmless against all claims, costs, damages, and expenses, and reasonable attorney fees arising out of, directly or indirectly, any claim of personal injury or death associated with such unintended or unauthorized use, even if such claim alleges that Motorola was negligent regarding the design or manufacture of the part.



Motorola and the Stylized M Logo are registered in the U.S. Patent and Trademark Office. digital dna is a trademark of Motorola, Inc. The described product contains a PowerPC processor core. The PowerPC name is a trademark of IBM Corp. and used under license. All other product or service names are the property of their respective owners. Motorola, Inc. is an Equal Opportunity/Affirmative Action Employer.

© Motorola, Inc. 2003

MPC8240EC

**For More Information On This Product,  
Go to: [www.freescale.com](http://www.freescale.com)**