

HCI1

MC68HC711L6

TECHNICAL
DATA



MOTOROLA

MC68HC711L6

HCMOS MICROCONTROLLER UNIT

Motorola reserves the right to make changes without further notice to any products herein to improve reliability, function or design. Motorola does not assume any liability arising out of the application or use of any product or circuit described herein; neither does it convey any license under its patent rights nor the rights of others. Motorola products are not designed, intended, or authorized for use as components in systems intended for surgical implant into the body, or other applications intended to support or sustain life, or for any other application in which the failure of the Motorola product could create a situation where personal injury or death may occur. Should Buyer purchase or use Motorola products for any such unintended or unauthorized application, Buyer shall indemnify and hold Motorola and its officers, employees, subsidiaries, affiliates, and distributors harmless against all claims, costs, damages, and expenses, and reasonable attorney fees arising out of, directly or indirectly, any claim of personal injury or death associated with such unintended or unauthorized use, even if such claim alleges that Motorola was negligent regarding the design or manufacture of the part. Motorola and  are registered trademarks of Motorola, Inc. Motorola, Inc. is an Equal Employment Opportunity/Affirmative Action Employer.

TABLE OF CONTENTS

Paragraph	Title	Page
Section 1		
Introduction		
1.1	Features.....	1-1
1.2	Structure.....	1-2

Section 2 Pin Descriptions

2.1	V_{DD} and V_{SS}	2-2
2.2	RESET	2-3
2.3	Crystal Driver and External Clock Input	2-3
2.4	E-Clock Output	2-5
2.5	Interrupt Request.....	2-5
2.6	Nonmaskable Interrupt	2-5
2.7	MODA and MODB	2-5
2.8	V_{RL} and V_{RH}	2-6
2.9	STRA/AS	2-6
2.10	STRB/R \overline{W}	2-6
2.11	Port Signals	2-7
2.11.1	Port A.....	2-9
2.11.2	Port B.....	2-9
2.11.3	Port C.....	2-9
2.11.4	Port D	2-10
2.11.5	Port E.....	2-10
2.11.6	Port G	2-10

Section 3 Central Processing Unit

3.1	CPU Registers.....	3-1
3.1.1	Accumulators A, B, and D.....	3-2
3.1.2	Index Register X (IX).....	3-2
3.1.3	Index Register Y (IY).....	3-2
3.1.4	Stack Pointer (SP).....	3-2

TABLE OF CONTENTS

Paragraph	Title	Page
3.1.4	Stack Pointer (SP).....	3-2
3.1.5	Program Counter (PC).....	3-4
3.1.6	Condition Code Register (CCR).....	3-4
3.1.6.1	Carry/Borrow (C).....	3-5
3.1.6.2	Overflow (V).....	3-5
3.1.6.3	Zero (Z).....	3-5
3.1.6.4	Negative (N).....	3-5
3.1.6.5	Interrupt Mask (I).....	3-5
3.1.6.6	Half Carry (H).....	3-6
3.1.6.7	X Interrupt Mask (X).....	3-6
3.1.6.8	Stop Disable (S).....	3-6
3.2	Data Types.....	3-6
3.3	Opcodes and Operands.....	3-7
3.4	Addressing Modes.....	3-7
3.4.1	Immediate.....	3-7
3.4.2	Direct.....	3-7
3.4.3	Extended.....	3-8
3.4.4	Indexed.....	3-8
3.4.5	Inherent.....	3-8
3.4.6	Relative.....	3-8
3.5	Instruction Set.....	3-8

Section 4 Operating Modes and On-Chip Memory

4.1	Operating Modes.....	4-1
4.1.1	Single-Chip Mode.....	4-1
4.1.2	Expanded Multiplexed Mode.....	4-1
4.1.3	Special Test Mode.....	4-2
4.1.4	Bootstrap Mode.....	4-2
4.2	Memory Map.....	4-3
4.2.1	Priority and Mode Select Register.....	4-7
4.2.2	System Initialization.....	4-9
4.2.2.1	CONFIG Register.....	4-9
4.2.2.2	INIT Register.....	4-10
4.2.2.3	OPTION Register.....	4-11
4.2.2.4	BPROT Register.....	4-12
4.2.3	EPROM, EEPROM and CONFIG Programming.....	4-13
4.2.3.1	EPROM Programming.....	4-13
4.2.3.2	EEPROM Programming.....	4-15
4.2.3.3	EEPROM Bulk Erase.....	4-17

TABLE OF CONTENTS

Paragraph	Title	Page
4.2.3.4	EEPROM Row Erase.....	4-18
4.2.3.5	EEPROM Byte Erase.....	4-18
4.2.3.6	CONFIG Register Programming.....	4-18
4.2.3.7	EEPROM Security.....	4-18

Section 5 Resets and Interrupts

5.1	Resets.....	5-1
5.1.1	Power-On Reset.....	5-1
5.1.2	External Reset	5-1
5.1.3	COP Reset.....	5-2
5.1.4	Clock Monitor Reset	5-3
5.1.5	Option Register.....	5-4
5.1.6	CONFIG Register	5-4
5.2	Effects of Reset.....	5-5
5.2.1	Central Processing Unit.....	5-5
5.2.2	Memory Map.....	5-5
5.2.3	Parallel I/O.....	5-5
5.2.4	Timer.....	5-6
5.2.5	Real-Time Interrupt	5-6
5.2.6	Pulse Accumulator.....	5-6
5.2.7	Computer Operating Properly	5-6
5.2.8	Serial Communications Interface	5-6
5.2.9	Serial Peripheral Interface.....	5-7
5.2.10	Analog-to-Digital Converter.....	5-7
5.2.11	System.....	5-7
5.3	Reset and Interrupt Priority.....	5-7
5.3.1	Highest Priority Interrupt and Miscellaneous Register.....	5-8
5.4	Interrupts.....	5-10
5.4.1	Interrupt Recognition and Register Stacking.....	5-11
5.4.2	Nonmaskable Interrupt Request	5-11
5.4.3	Illegal Opcode Trap.....	5-12
5.4.4	Software Interrupt	5-12
5.4.5	Maskable Interrupts.....	5-12
5.4.6	Reset and Interrupt Processing.....	5-13
5.5	Low Power Operation	5-19
5.5.1	WAIT	5-19
5.5.2	STOP.....	5-19

TABLE OF CONTENTS

Paragraph	Title	Page
-----------	-------	------

Section 6 Parallel Input/Output

6.1	Port A.....	6-1
6.2	Port B.....	6-2
6.3	Port C.....	6-2
6.4	Port D.....	6-3
6.5	Port E.....	6-4
6.6	Port G.....	6-5
6.7	Handshake Protocol.....	6-5
6.8	Parallel I/O Control Register	6-6

Section 7 Serial Communications Interface

7.1	Data Format	7-1
7.2	Transmit Operation.....	7-1
7.3	Receive Operation.....	7-2
7.4	Wake-up Feature	7-4
7.4.1	Idle-Line Wakeup.....	7-4
7.4.2	Address-Mark Wakeup	7-4
7.5	SCI Error Detection	7-5
7.6	SCI Registers.....	7-5
7.6.1	Serial Communications Data Register	7-5
7.6.2	Serial Communications Control Register 1	7-6
7.6.3	Serial Communications Control Register 2	7-6
7.6.4	Serial Communication Status Register	7-7
7.6.5	Baud Rate Register	7-9
7.7	Status Flags and Interrupts.....	7-11

Section 8 Serial Peripheral Interface

8.1	Functional Description.....	8-1
8.2	SPI Transfer Formats	8-2
8.2.1	Clock Phase and Polarity Controls.....	8-3
8.3	SPI Signals.....	8-3
8.3.1	Master In Slave Out.....	8-4
8.3.2	Master Out Slave In.....	8-4
8.3.3	Serial Clock	8-4
8.3.4	Slave Select	8-4

TABLE OF CONTENTS

Paragraph	Title	Page
8.4	SPI System Errors	8-5
8.5	SPI Registers.....	8-6
8.5.1	Serial Peripheral Control.....	8-6
8.5.2	Serial Peripheral Status.....	8-7
8.5.3	Serial Peripheral Data I/O.....	8-8

Section 9 Timing System

9.1	Timer Structure.....	9-3
9.2	Input Capture.....	9-5
9.2.1	Timer Control 2 Register	9-5
9.2.2	Timer Input Capture Registers.....	9-6
9.2.3	Timer Input Capture 4/Output Compare 5 Register.....	9-7
9.3	Output Compare.....	9-7
9.3.1	Timer Output Compare Registers	9-8
9.3.2	Timer Compare Force Register.....	9-9
9.3.3	Output Compare Mask Registers.....	9-9
9.3.4	Output Compare Data Register.....	9-10
9.3.5	Timer Counter Register.....	9-10
9.3.6	Timer Control 1 Register	9-10
9.3.7	Timer Interrupt Mask 1 Register	9-11
9.3.8	Timer Interrupt Flag 1 Register	9-11
9.3.9	Timer Interrupt Mask 2 Register	9-12
9.3.10	Timer Interrupt Flag 2 Register	9-13
9.4	Real-Time Interrupt.....	9-13
9.4.1	Timer Interrupt Mask 2 Register.....	9-14
9.4.2	Timer Interrupt Flag 2 Register	9-15
9.4.3	Pulse Accumulator Control Register	9-15
9.5	Computer Operating Properly Watchdog Function	9-16
9.5.1	Option Register.....	9-16
9.5.2	CONFIG Register	9-17
9.6	Pulse Accumulator.....	9-18
9.6.1	Pulse Accumulator Control Register	9-19
9.6.2	Pulse Accumulator Count Register.....	9-20
9.6.3	Pulse Accumulator Status and Interrupt Bits	9-20

Section 10 Analog-to-Digital Converter

10.1	Overview.....	10-1
10.1.1	Multiplexer.....	10-1

TABLE OF CONTENTS

Paragraph	Title	Page
10.1.2	Analog Converter.....	10-3
10.1.3	Digital Control.....	10-3
10.1.4	Result Registers	10-4
10.1.5	A/D Converter Clocks.....	10-4
10.1.6	Conversion Sequence.....	10-4
10.2	A/D Converter Power-Up and Clock Select.....	10-5
10.3	Conversion Process.....	10-6
10.4	Channel Assignments.....	10-6
10.5	Single-Channel Operation.....	10-6
10.6	Multiple-Channel Operation	10-7
10.7	Operation in STOP and WAIT Modes	10-7
10.8	A/D Control/Status Registers.....	10-7
10.9	A/D Converter Result Registers.....	10-9

Appendix A Electrical Characteristics

Appendix B Mechanical Data and Ordering Information

B.1	Pin Assignments	B-1
B.2	Package Dimensions.....	B-3
B.3	Mechanical Data and Ordering Information.....	B-6

Appendix C Development Support

C.1	Development System Tools.....	C-1
C.2	M68HC11L6EVS — Evaluation System.....	C-1
C.2.1	EVS Features	C-1

LIST OF ILLUSTRATIONS

Figure	Title	Page
1-1	MC68HC711L6 Block Diagram	1-2
2-1	Pin Assignments for 68-Pin PLCC/Cerquad.....	2-1
2-2	Pin Assignments for 64-Pin QFP.....	2-2
2-3	External Reset Circuit.....	2-3
2-4	Common Crystal Connections	2-4
2-5	External Oscillator Connections.....	2-4
2-6	One Crystal Driving Two MCUs	2-4
3-1	Programming Model.....	3-1
3-2	Stacking Operations.....	3-3
4-1	Address/Data Demultiplexing.....	4-2
4-2	Memory Map.....	4-3
4-3	RAM Standby MODB/VSTBY Connections	4-6
4-4	MC68HC711L6 PROG Mode Connections	4-15
5-1	Processing Flow out of Reset	5-14
5-2	Interrupt Priority Resolution	5-16
5-3	Interrupt Source Resolution Within SCI.....	5-18
7-1	SCI Transmitter Block Diagram.....	7-2
7-2	SCI Receiver Block Diagram.....	7-3
7-3	SCI Baud Rate Diagram.....	7-11
7-4	Interrupt Source Resolution Within SCI.....	7-13
8-1	SPI Block Diagram	8-2
8-2	SPI Transfer Format	8-3
9-1	Timer Clock Divider Chains.....	9-2
9-2	Capture/Compare Block Diagram	9-4
9-3	Pulse Accumulator.....	9-19
10-1	A/D Converter Block Diagram	10-2
10-2	Electrical Model of an A/D Input Pin (Sample Mode).....	10-3
10-3	A/D Conversion Sequence.....	10-4
A-1	Test Methods	A-3

LIST OF ILLUSTRATIONS

Figure	Title	Page
A-2	Timer Inputs	A-4
A-3	POR and External Reset Timing.....	A-5
A-4	STOP Recovery Timing	A-6
A-5	WAIT Recovery Timing.....	A-7
A-6	Interrupt Timing	A-8
A-7	Port Write Timing Diagram.....	A-10
A-8	Port Read Timing Diagram.....	A-10
A-9	Simple Output Strobe Timing Diagram	A-10
A-10	Simple Input Strobe Timing Diagram	A-11
A-11	Port C Input Handshake Timing Diagram	A-11
A-12	Port C Output Handshake Timing Diagram	A-11
A-13	Three-State Variation of Output Handshake Timing Diagram	A-12
A-14	Multiplexed Expansion Bus Timing Diagram	A-15
A-15	SPI Timing Diagram.....	A-17
B-1	64-Pin QFP.....	B-1
B-2	68-Pin PLCC/Cerquad.....	B-2
B-3	Case Outline #840B-01	B-3
B-4	Case Outline #779A-01	B-4
B-5	Case Outline #779-02.....	B-5
B-6	Part Number Options.....	B-6

LIST OF TABLES

Table	Title	Page
2-1	Port Signal Functions.....	2-8
3-1	Reset Vector Comparison	3-4
3-2	Instruction Set Summary	3-9
4-1	Register and Control Bit Assignments	4-4
4-2	Hardware Mode Select Summary	4-7
4-3	IRVNE Status.....	4-8
4-4	RAM Mapping.....	4-11
4-5	Register Mapping.....	4-11
4-6	EEPROM Block Protect.....	4-13
4-7	EEPROM Erase	4-16
5-1	COP Timeout	5-2
5-2	Reset Cause, Reset Vector, and Operating Mode.....	5-5
5-3	Highest Priority Interrupt Selection.....	5-9
5-4	Interrupt and Reset Vector Assignments	5-10
5-5	Stacking Order on Entry to Interrupts.....	5-11
6-1	I/O Ports	6-1
6-2	Parallel I/O Control	6-8
7-1	Baud Rate Prescale Selects.....	7-9
7-2	Baud Rate Selects.....	7-10
9-1	Timer Summary.....	9-3
9-2	Timer Control Configuration	9-6
9-3	Pulse Accumulator Timing	9-19
10-1	Channel Assignments.....	10-6
10-2	A/D Converter Channel Selection.....	10-9
A-1	Maximum Ratings	A-1
A-2	Thermal Characteristics.....	A-1
A-3	DC Electrical Characteristics.....	A-2
A-4	Control Timing.....	A-4
A-5	Peripheral Port Timing.....	A-9
A-6	Analog-To-Digital Converter Characteristics.....	A-13

LIST OF TABLES

Table	Title	Page
A-6	Analog-To-Digital Converter Characteristics.....	A-13
A-7	Expansion Bus Timing.....	A-14
A-8	Serial Peripheral Interface (SPI) Timing	A-16
A-9	EEPROM Characteristics.....	A-19
B-1	Ordering Information	B-6

SECTION 1 INTRODUCTION

The MC68HC711L6 high-performance microcontroller (MCU) is an erasable programmable ROM (EPROM)-based version of the MC68HC11L6 and includes similar features — 16 Kbytes of EPROM, 512 bytes of electrically erasable programmable ROM (EEPROM), and 512 bytes of RAM. The MC68HC711L6, with integral multiplexed bus, is a high-speed, low-power chip capable of running at up to 3 MHz. Its fully static design allows it to operate at frequencies down to dc.

1.1 Features

- MC68HC11 Central Processing Unit (CPU)
- Power Saving STOP and WAIT Modes
- 16 Kbytes of On-Chip EPROM or One-Time Programmable ROM (OTPROM)
- 512 Bytes of On-Chip EEPROM with Block Protect for Extra Security
- 512 Bytes of On-Chip RAM (All Saved During Standby)
- 16-Bit Timer System
 - Four Output Compare Channels
 - Three Input Capture Channels
 - One Input Capture or Output Compare Channel (Software Selectable)
- 8-Bit Pulse Accumulator
- Real-Time Interrupt Circuit
- Computer Operating Properly (COP) Watchdog System
- Synchronous Serial Peripheral Interface (SPI)
- Asynchronous Nonreturn to Zero (NRZ) Serial Communications Interface (SCI)
- 8-Channel 8-Bit Analog-to-Digital (A/D Converter)
- 46 General-Purpose Input/Output (I/O) Pins
 - 24 Bidirectional I/O Pins
 - 11 Input Only Pins
 - 11 Output Only Pins
- Available in a 68-Pin Plastic Leaded Chip Carrier (PLCC), 68-Pin Ceramic Cerquad, or 64-pin Quad Flat Pack (QFP)

1.2 Structure

Refer to Figure 1–1, which shows the structure of the MC68HC711L6 MCU.

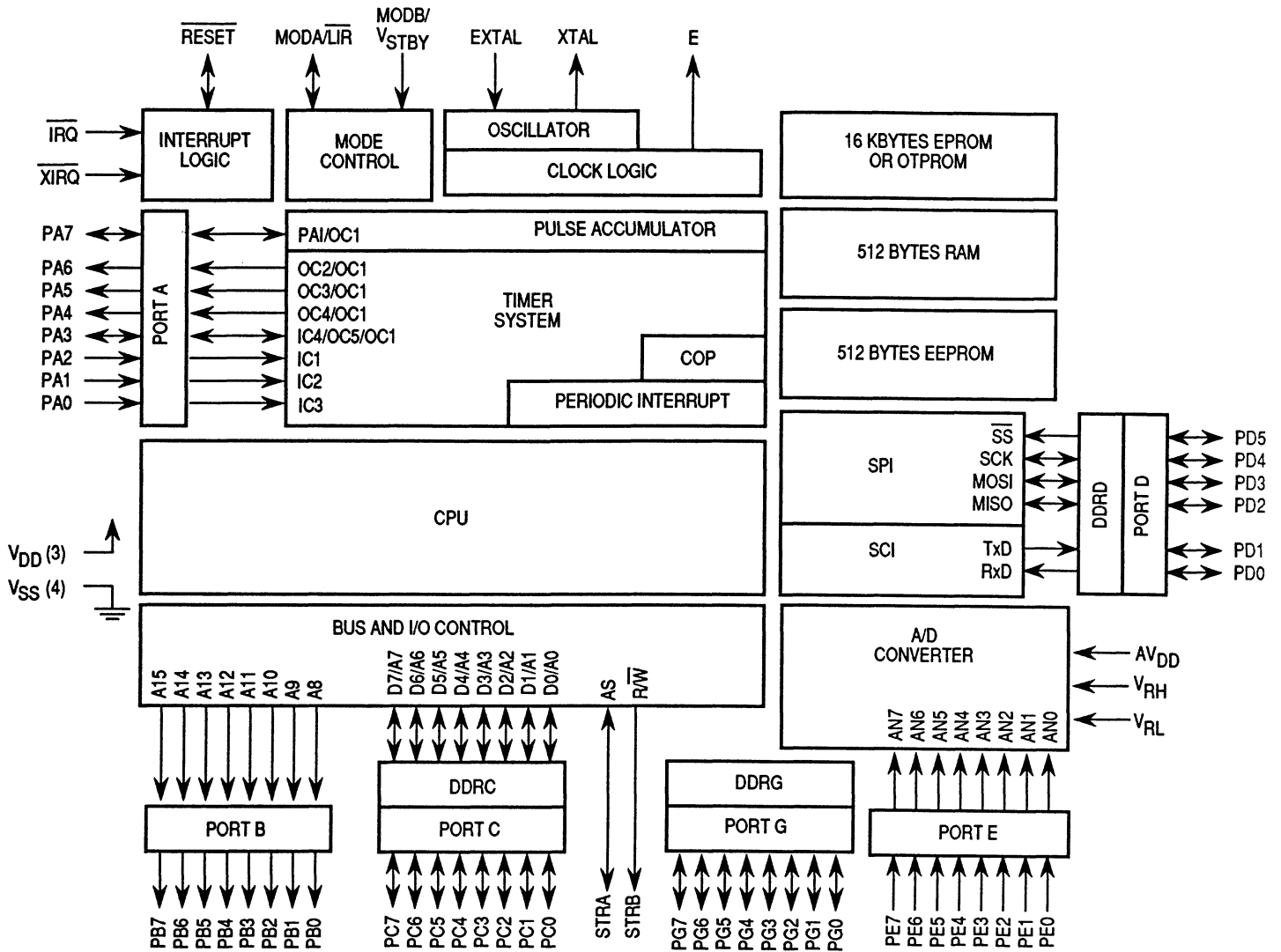

Figure 1–1. MC68HC711L6 Block Diagram

SECTION 2 PIN DESCRIPTIONS

The MC68HC711L6 is available as a one-time programmable (OTP) MCU, packaged as a 68-pin plastic leaded chip carrier (PLCC) and a 64-pin quad flat pack (QFP). Most pins on this MCU serve two or more functions, as described in the following paragraphs. Refer to Figures 2–1 and 2–2, which show the MC68HC711L6 pin assignments.

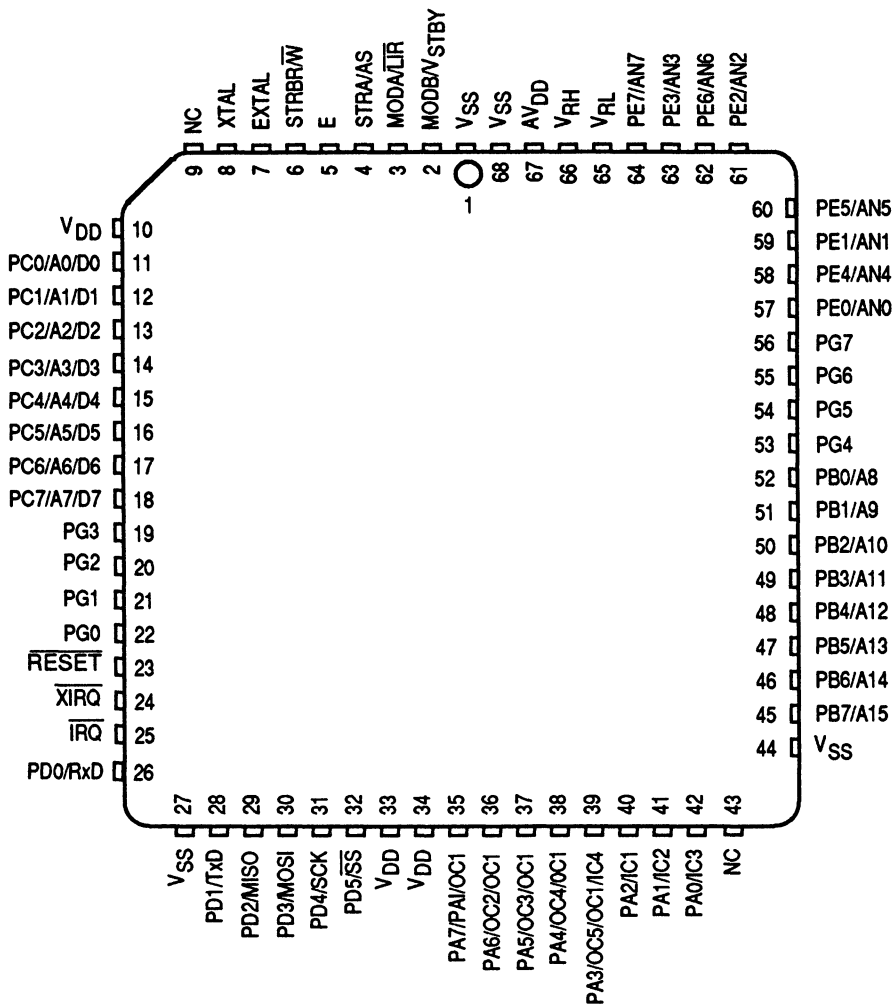

Figure 2–1. Pin Assignments for 68-Pin PLCC/Cerquad

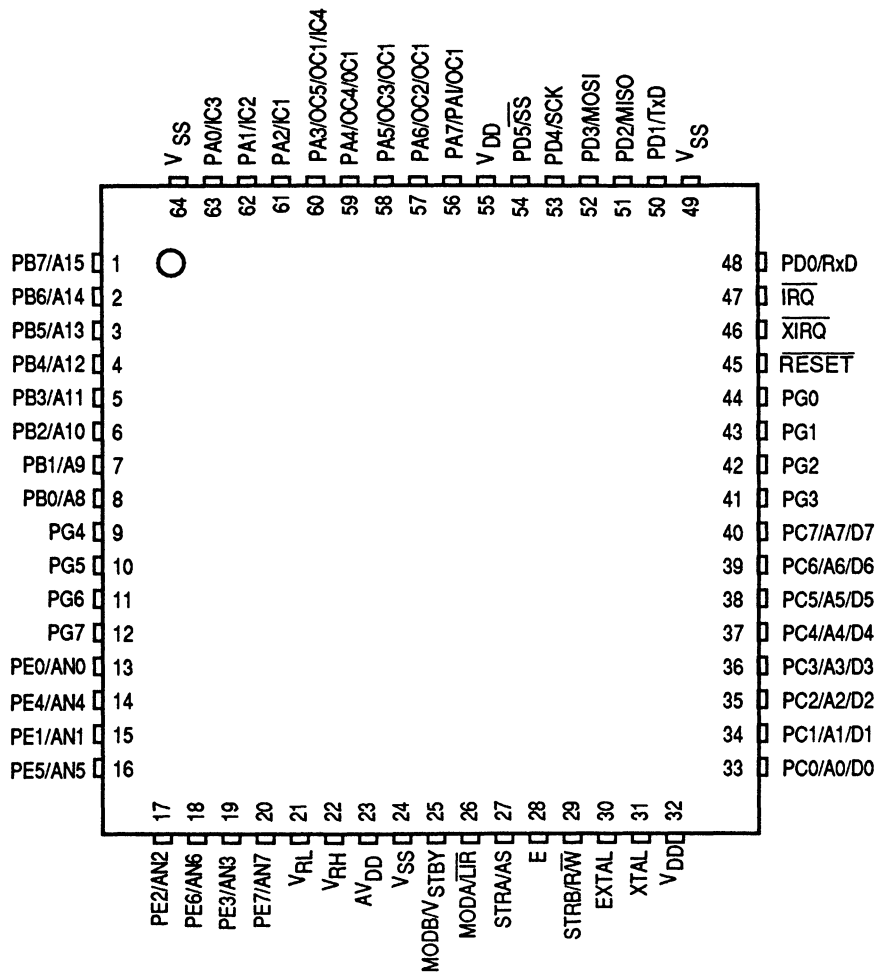

Figure 2–2. Pin Assignments for 64-Pin QFP

2.1 V_{DD} and V_{SS}

Power is supplied to the MCU through V_{DD} and V_{SS}. V_{DD} is the power supply, V_{SS} is ground. The MCU operates from a single 5-volt (nominal) power supply. Very fast signal transitions occur on the MCU pins. The short rise and fall times place high, short duration current demands on the power supply. To prevent noise problems, provide good power supply bypassing at the MCU. Also, use bypass capacitors that have good high-frequency characteristics and situate them as close to the MCU as possible. Bypass requirements vary, depending on how heavily the MCU pins are loaded. Connection of all the additional V_{SS} pins on the MC68HC711L6 reduces the impact of RFI emissions.

The AV_{DD} pin supplies the digital section of the analog circuit.

2.2 RESET

An active low bidirectional control signal, $\overline{\text{RESET}}$, acts as an input to initialize the MCU to a known startup state. It also acts as an open-drain output to indicate that an internal failure has been detected in either the clock monitor or COP watchdog circuit. The CPU distinguishes between internal and external reset conditions by sensing whether the reset pin rises to a logic one in less than two E-clock cycles after a reset has occurred. It is not advisable to connect an external resistor capacitor (RC) power-up delay circuit to the reset pin of M68HC11 devices because the circuit charge time constant can cause the device to misinterpret the type of reset that occurred. Refer to **SECTION 5 RESETS AND INTERRUPTS** for further information. Figure 2-3 illustrates a reset circuit that uses an external switch. Other circuits can be used, however, it is important to incorporate a low voltage interrupt (LVI) circuit to prevent power transitions or corruption of RAM or EEPROM.

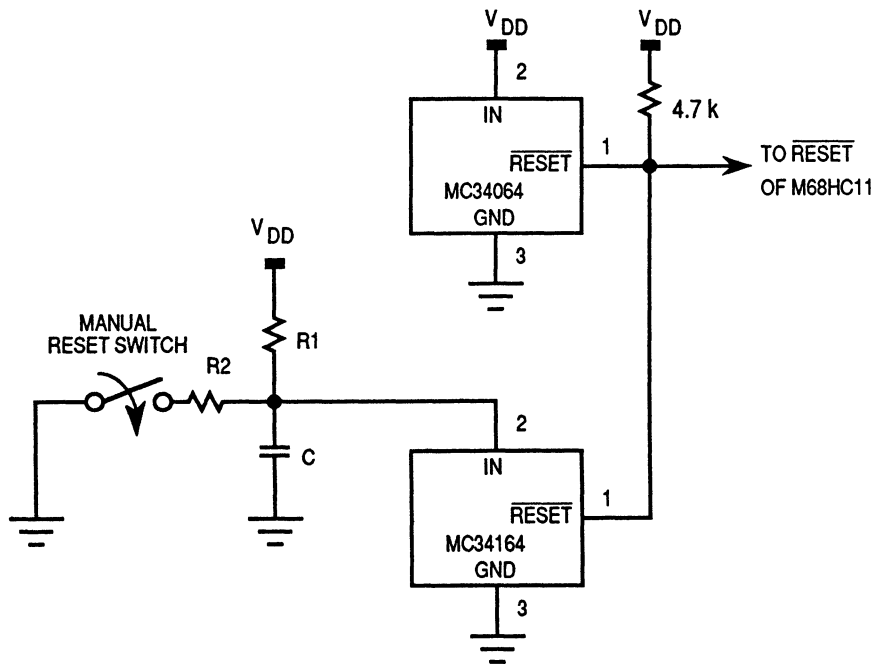

Figure 2-3. External Reset Circuit

2.3 Crystal Driver and External Clock Input

These two pins provide the interface for either a crystal or a CMOS compatible clock to control the internal clock generator circuitry. The frequency applied to these pins is four times higher than the desired E-clock rate.

The XTAL pin is normally left unterminated when an external CMOS compatible clock input is connected to the EXTAL pin. However, a 10 k Ω to 100 k Ω load

resistor connected from XTAL to ground can be used to reduce RFI noise emission. The XTAL output is normally intended to drive only a crystal. The XTAL output can be buffered with a high impedance buffer, or it can be used to drive the EXTAL input of another MC68HC11.

In all cases, use caution around the oscillator pins. Load capacitances shown in the oscillator circuits include all stray layout capacitances. Refer to Figures 2-4, 2-5, and 2-6.

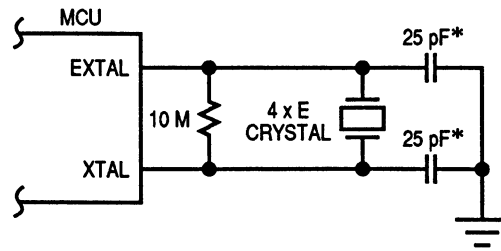

* Values include all stray capacitances.

Figure 2-4. Common Crystal Connections

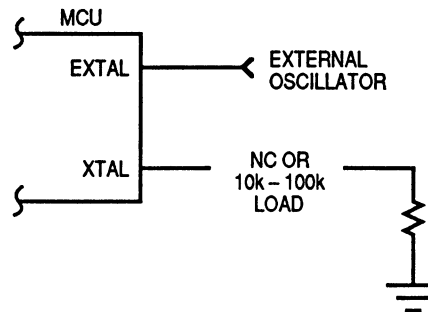

Figure 2-5. External Oscillator Connections

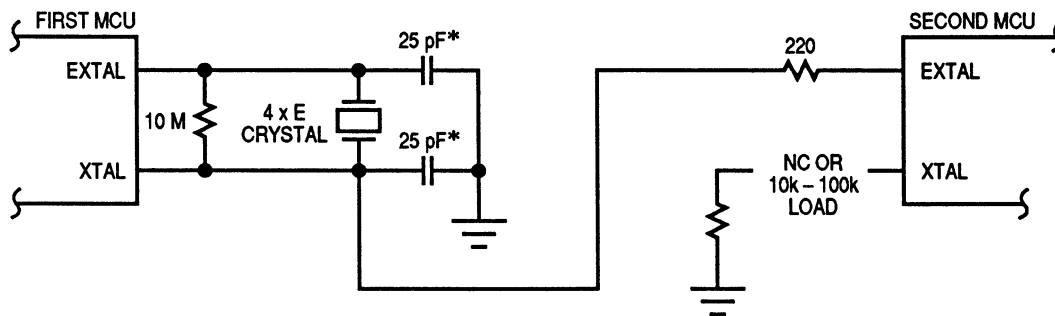

Figure 2-6. One Crystal Driving Two MCUs

2.4 E-Clock Output

E-clock output (E) is the output connection for the internally generated E clock. The signal from E is used as a timing reference. The frequency of the E-clock output is one fourth that of the input frequency at the XTAL and EXTAL pins. When E-clock output is low, an internal process is taking place. When it is high, data is being accessed. All clocks, including the E clock, are halted when the MCU is in STOP mode. To reduce RFI effects, the E clock can be turned off in single-chip modes.

2.5 Interrupt Request

The interrupt request ($\overline{\text{IRQ}}$) input provides a means of applying asynchronous interrupt requests to the MCU. Either negative edge-sensitive triggering or level-sensitive triggering is program selectable (OPTION register). $\overline{\text{IRQ}}$ is always configured to level-sensitive triggering at reset. When using $\overline{\text{IRQ}}$ in a level sensitive wired-OR configuration, connect an external pullup resistor, typically 4.7 k Ω , to V_{DD} .

2.6 Nonmaskable Interrupt

The nonmaskable interrupt ($\overline{\text{XIRQ}}$) input provides a means of requesting a nonmaskable interrupt after reset initialization. During reset, the X bit in the condition code register (CCR) is set and any interrupt is masked until MCU software enables it. Because the $\overline{\text{XIRQ}}$ input is level-sensitive, it can be connected to a multiple-source wired-OR network with an external pullup resistor to V_{DD} . $\overline{\text{XIRQ}}$ is often used as a power loss detect interrupt.

Whenever $\overline{\text{XIRQ}}$ or $\overline{\text{IRQ}}$ are used with multiple interrupt sources ($\overline{\text{IRQ}}$ must be configured for level-sensitive operation if there is more than one source of $\overline{\text{IRQ}}$ interrupt), each source must drive the interrupt input with an open-drain type of driver to avoid contention between outputs. There should be a single pullup resistor near the MCU interrupt input pin (typically 4.7 k Ω). There must also be an interlock mechanism at each interrupt source so that the source holds the interrupt line low until the MCU recognizes and acknowledges the interrupt request. If one or more interrupt sources are still pending after the MCU services a request, the interrupt line will still be held low and the MCU will be interrupted again as soon as the interrupt mask bit in the MCU is cleared (normally upon return from an interrupt). Refer to **SECTION 5 RESETS AND INTERRUPTS**.

2.7 MODA and MODB

During reset, MODA and MODB select one of the four operating modes. Refer to **SECTION 4 OPERATING MODES AND ON-CHIP MEMORY**.

After the operating mode has been selected, the $\overline{\text{LIR}}$ pin provides an open-drain output to indicate that execution of an instruction has begun. A series of E-clock cycles occurs during execution of each instruction. The $\overline{\text{LIR}}$ signal goes low during the first E-clock cycle of each instruction (opcode fetch). This output is provided for assistance in program debugging.

The V_{STBY} pin is used to input RAM standby power. When the voltage on this pin is more than one MOS threshold (about 0.7 volts) above the V_{DD} voltage, the internal 512-byte RAM and part of the reset logic are powered from this signal rather than the V_{DD} input. This allows RAM contents to be retained without V_{DD} power applied to the MCU. Reset must be driven low before V_{DD} is removed and must remain low until V_{DD} has been restored to a valid level.

2.8 V_{RL} and V_{RH}

These two inputs provide the reference voltages for the analog-to-digital converter circuitry. V_{RL} is the low reference, typically 0 Vdc. V_{RH} is the high reference. For proper A/D converter operation, V_{RH} should be at least 3 Vdc greater than V_{RL} , and both V_{RL} and V_{RH} should be between V_{SS} and V_{DD} .

2.9 STRA/AS

This pin performs either of two separate functions, depending on the operating mode. In single-chip mode, STRA performs an input handshake (strobe input) function. In the expanded multiplexed mode, AS provides an address strobe function. AS can be used to demultiplex the address and data signals at port C. Refer to **SECTION 4 OPERATING MODES AND ON-CHIP MEMORY** for further information about STRA.

2.10 STRB/R/ $\overline{\text{W}}$

The strobe B and read/write pin acts as either an output strobe, or as a data bus direction indicator, depending on the operating mode. In single-chip operating mode, STRB acts as a programmable strobe for handshake with other parallel devices. Refer to **SECTION 6 PARALLEL INPUT/OUTPUT** for further information.

In expanded multiplexed operating mode, $\overline{\text{R/W}}$ is used to indicate the direction of transfers on the external data bus. A low on the $\overline{\text{R/W}}$ pin indicates data is being written to the external data bus. A high on this pin indicates that a read cycle is in progress. $\overline{\text{R/W}}$ stays low during consecutive data bus write cycles, such as a double-byte store. It is possible for data to be driven out port C, if IRVNE is enabled and an internal address is read, even though $\overline{\text{R/W}}$ is high. This situation, however, can only occur during debug in test or bootstrap modes. Refer to **SECTION 4 OPERATING MODES AND ON-CHIP MEMORY** for more information about IRVNE.

2.11 Port Signals

Port pins have different functions in different operating modes. Pin functions for ports A, D, and E are independent of operating modes. Ports B and C, however, are affected by operating mode. Port B provides eight general-purpose output signals in single-chip operating modes. When the microcontroller is in expanded multiplexed operating mode, port B pins are the eight high-order address lines. Port C provides eight general-purpose input/output signals when the MCU is in the single-chip operating mode. When the microcontroller is in the expanded multiplexed operating mode, port C pins are a multiplexed address/data bus. Refer to Table 2–1 for details about the 40 port signals' functions within different operating modes. Terminate unused inputs and I/O pins configured as inputs high or low.

Table 2–1. Port Signal Functions

Port/Bit	Single-Chip and Bootstrap Mode	Expanded Multiplexed and Special Test Mode
PA0	PA0/IC3	
PA1	PA1/IC2	
PA2	PA2/IC1	
PA3	PA3/OC5/IC4/and-or OC1	
PA4	PA4/OC4/and-or OC1	
PA5	PA5/OC3/and-or OC1	
PA6	PA6/OC2/and-or OC1	
PA7	PA7/PAI/and-or OC1	
PB0	PB0	A8
PB1	PB1	A9
PB2	PB2	A10
PB3	PB3	A11
PB4	PB4	A12
PB5	PB5	A13
PB6	PB6	A14
PB7	PB7	A15
PC0	PC0	A0/D0
PC1	PC1	A1/D1
PC2	PC2	A2/D2
PC3	PC3	A3/D3
PC4	PC4	A4/D4
PC5	PC5	A5/D5
PC6	PC6	A6/D6
PC7	PC7	A7/D7
PD0	PD0/RxD	
PD1	PD1/TxD	
PD2	PD2/MISO	
PD3	PD3/MOSI	
PD4	PD4/SCK	
PD5	PD5/ \overline{SS}	
—	STRA	AS
—	STRB	$\overline{R/W}$
PE0	PE0/AN0	
PE1	PE1/AN1	
PE2	PE3/AN2	
PE3	PE3/AN3	
PE4	PE4/AN4	
PE5	PE5/AN5	
PE6	PE6/AN6	
PE7	PE7/AN7	

2.11.1 Port A

In all operating modes, port A can be configured for four timer input capture (IC) functions and four timer output compare (OC) functions, or for four OC and three IC functions, and either a pulse accumulator input (PAI), or a fifth OC function. Any port A pin that is not used for an alternate timer function can be used as a general-purpose input or output line.

PA7 can function as general-purpose I/O or as timer output compare for OC1. PA7 is also the input to the pulse accumulator, even while functioning as a general-purpose I/O or an OC1 output.

PA6–PA4 serve as either general-purpose outputs, timer input captures or timer output compare 2–4 respectively. In addition, PA6–PA4 can be controlled by OC1.

PA3 can be a general-purpose I/O pin or a timer IC/OC pin. Timer functions associated with this pin include OC1 and IC4/OC5. IC4/OC5 is software selectable as either a fourth input capture, or a fifth output compare. PA3 can also be configured to allow OC1 edges to trigger IC4 captures.

PA2–PA0 serve as general-purpose inputs or as IC1–IC3.

PORTA can be read at any time. Reads of pins configured as inputs return the logic level present on the pin. Pins configured as outputs return the logic level present at the pin driver input. If written, PORTA stores the data in an internal latch, bits 7 and 3. It drives the pins only if they are configured as outputs. Writes to PORTA do not change the pin state when pins are configured for timer input captures or output compares. Refer to **SECTION 6 PARALLEL INPUT/OUTPUT**.

2.11.2 Port B

During single-chip operating modes, all port B pins are general-purpose output pins. During MCU reads of this port, the level sensed at the input side of the port B output drivers is read. Port B can also be used in a simple strobed output mode where an output pulse appears at the STRB signal each time data is written to port B.

In expanded multiplexed operating modes, all of the port B pins act as high order address output signals. During each MCU cycle, bits 15 through 8 of the address bus are output on the PB[7:0] lines respectively. The PORTB register is treated as an external address in expanded modes.

2.11.3 Port C

While in single-chip operating modes, all port C pins are general-purpose input/output pins. Port C inputs can be latched into an alternate PORTCL register by providing an input transition to the STRA signal. Port C can also be used in full handshake modes of parallel I/O where the STRA input and STRB output act as handshake control lines.

When in expanded multiplexed modes, all port C pins are configured as multiplexed address/data signals. During the address portion of each MCU cycle, bits 0–7 of the address are output on the PC[7:0] lines. During the data portion of each MCU cycle (E high), pins 0–7 are bidirectional data signals, D[7:0]. The direction of data at the port C pins is indicated by the R/W signal.

The CWOM control bit in the PIOC register disables the port C P-channel output driver. CWOM simultaneously affects all eight bits of port C. Because the N-channel driver is not affected by CWOM, setting CWOM causes port C to become an open-drain-type output port suitable for wired-OR operation. In wired-OR mode, when a port C bit is at logic level zero, it is actively driven low by the N-channel driver. When a port C bit is at logic level one, the associated pin has high impedance, as neither the N- nor the P-channel devices are active. It is customary to have an external pullup resistor on lines that are driven by open-drain devices. Port C can only be configured for wired-OR operation when the MCU is in single-chip mode. Refer to **SECTION 6 PARALLEL INPUT/OUTPUT** for additional information about port C functions.

2.11.4 Port D

Pins PD5–0 can be used for general-purpose I/O signals. These pins alternately serve as the serial communication interface (SCI), and serial peripheral interface (SPI) signals when those subsystems are enabled.

Pin PD0 is the receive data input (RxD) signal for the SCI.

Pin PD1 is the transmit data output (TxD) signal for the SCI.

Pins PD5–2 are dedicated to the SPI. PD2 is the master in slave out (MISO) signal. PD3 is the master out slave in (MOSI) signal. PD4 is the serial clock (SCK) signal and PD5 is the slave select (\overline{SS}) input.

2.11.5 Port E

Use port E for general-purpose or analog-to-digital (A/D) inputs. If high accuracy is required for A/D conversions, avoid reading port E during sampling, as small disturbances can reduce the accuracy of that result.

2.11.6 Port G

Each port G bit can be selected as general-purpose output or input.

SECTION 3 CENTRAL PROCESSING UNIT

Section 3 presents information on M68HC11 central processing unit (CPU) architecture, data types, addressing modes, the instruction set, and special operations, such as subroutine calls and interrupts.

The CPU is designed to treat all peripheral, I/O, and memory locations identically as addresses in the 64 Kbyte memory map. This is referred to as memory-mapped I/O. There are no special instructions for I/O that are separate from those used for memory. This architecture also allows accessing an operand from an external memory location with no execution-time penalty.

3.1 CPU Registers

M68HC11 CPU registers are an integral part of the CPU and are not addressed as if they were memory locations. The seven registers, discussed in the following paragraphs, are shown in Figure 3-1.

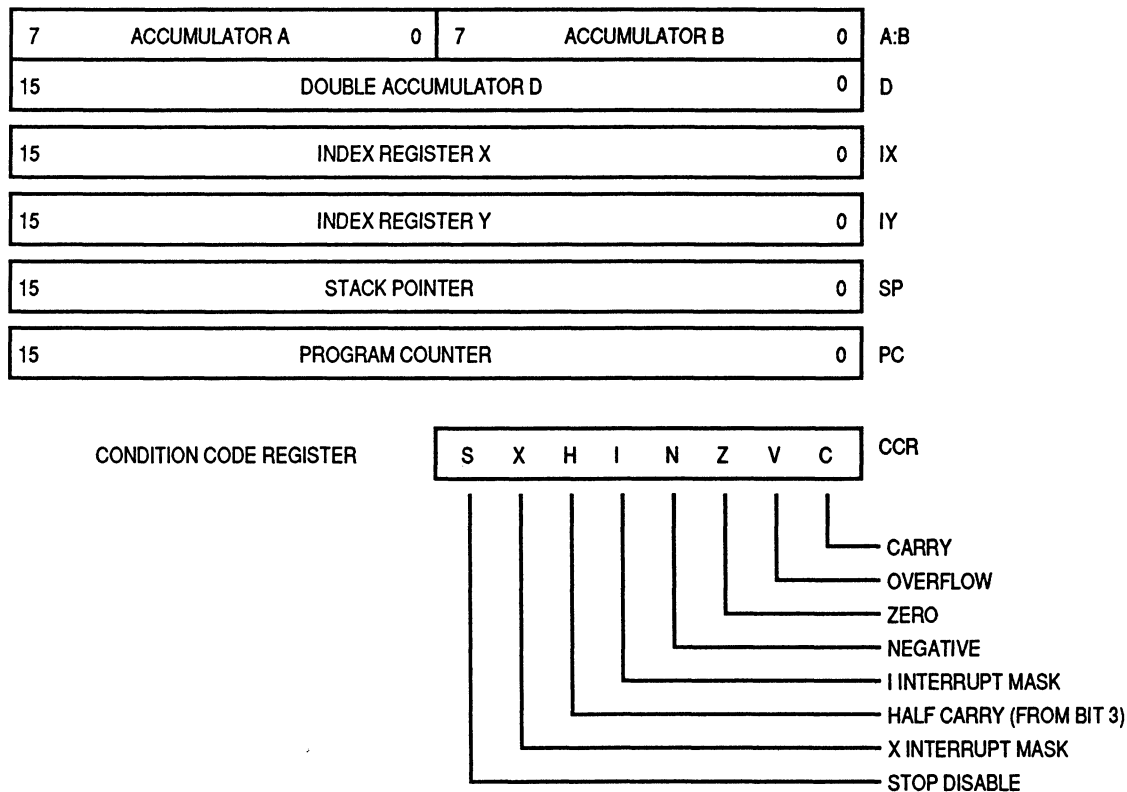

Figure 3-1. Programming Model

3.1.1 Accumulators A, B, and D

Accumulators A and B are general-purpose 8-bit registers that hold operands and results of arithmetic calculations or data manipulations. For some instructions, these two accumulators are treated as a single double-byte (16-bit) accumulator called accumulator D. Although most operations can use accumulators A or B interchangeably, the following exceptions apply:

The ABX and ABY instructions add the contents of 8-bit accumulator B to the contents of 16-bit register X or Y, but there are no equivalent instructions that use A instead of B.

The TAP and TPA instructions transfer data from accumulator A to the condition code register, or from the condition code register to accumulator A, however there are no equivalent instructions that use B rather than A.

The decimal adjust accumulator A (DAA) instruction is used after binary-coded decimal (BCD) arithmetic operations, but there is no equivalent BCD instruction to adjust accumulator B.

The add, subtract, and compare instructions associated with both A and B (ABA, SBA, and CBA) only operate in one direction, making it important to plan ahead to ensure the correct operand is in the correct accumulator.

3.1.2 Index Register X (IX)

The IX register provides a 16-bit indexing value that can be added to the 8-bit offset provided in an instruction to create an effective address. The IX register can also be used as a counter or as a temporary storage register.

3.1.3 Index Register Y (IY)

The 16-bit IY register performs an indexed mode function similar to that of the IX register. However, most instructions using the IY register require an extra byte of machine code and an extra cycle of execution time because of the way the opcode map is implemented. Refer to **3.3 Opcodes and Operands** for further information.

3.1.4 Stack Pointer (SP)

The M68HC11 CPU has an automatic program stack. This stack can be located anywhere in the address space and can be any size up to the amount of memory available in the system. Normally the SP is initialized by one of the first instructions in an application program. The stack is configured as a data structure that grows downward from high memory to low memory. Each time a new byte is pushed onto the stack, the SP is decremented. Each time a byte is pulled from the stack, the SP is incremented. At any given time, the SP holds the 16-bit address of the next free location in the stack. Figure 3-2 is a summary of SP operations.

JSR, JUMP TO SUBROUTINE

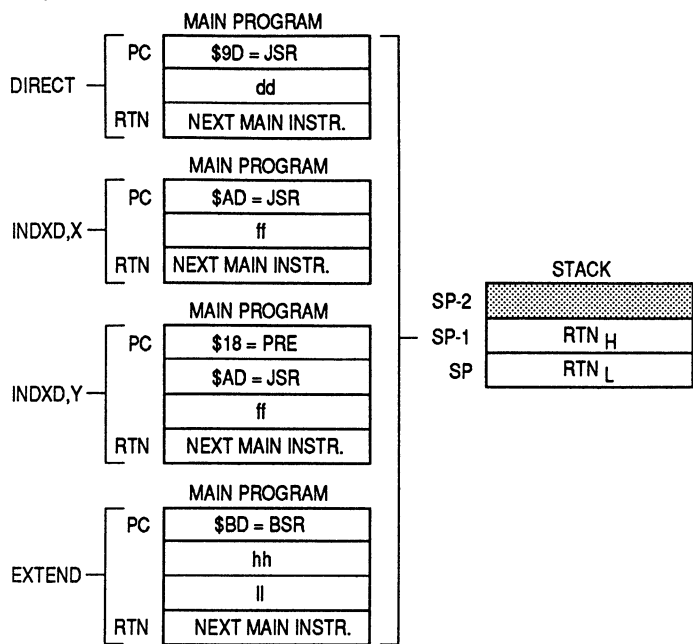

BSR, BRANCH TO SUBROUTINE

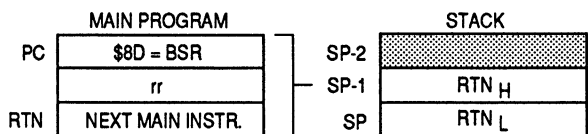

RTS, RETURN FROM SUBROUTINE

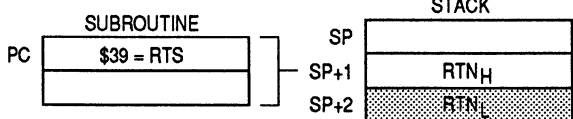

RTI, RETURN FROM INTERRUPT

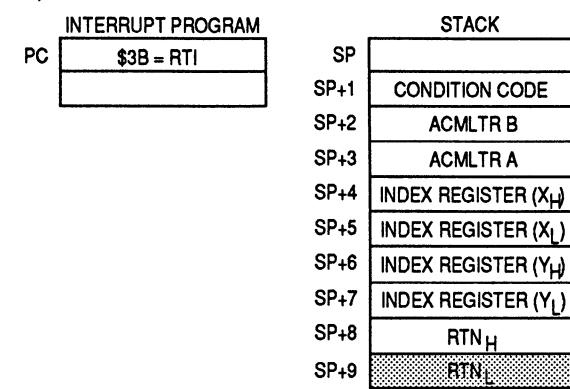

SWI, SOFTWARE INTERRUPT

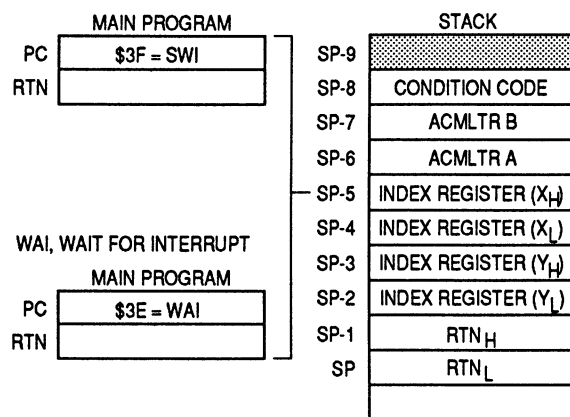

WAI, WAIT FOR INTERRUPT

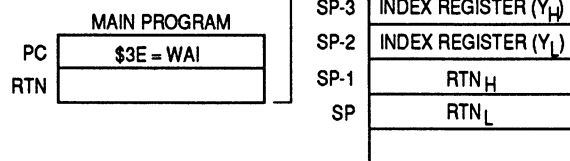

LEGEND:

- RTN Address of next instruction in main program to be executed upon return from subroutine
- RTN_H Most significant byte of return address
- RTN_L Least significant byte of return address
- Shaded cells show stack pointer position after operation is complete
- dd 8-bit direct address (\$0000-\$00FF) (high byte assumed to be \$00)
- ff 8-bit positive offset \$00 (0) to \$FF (256) is added to index
- hh High-order byte of 16-bit extended address
- ll Low-order byte of 16-bit extended address
- rr Signed-relative offset \$80 (-128) to \$7F (+127) (offset relative to the address following the machine code offset byte)

Figure 3-2. Stacking Operations

When a subroutine is called by a jump to subroutine (JSR) or branch to subroutine (BSR) instruction, the address of the instruction after the JSR or BSR is automatically pushed onto the stack, least significant byte first. When the subroutine is finished, a return from subroutine (RTS) instruction is executed. The RTS pulls the previously stacked return address from the stack, and loads it into the program counter. Execution then continues at this recovered return address.

When an interrupt is recognized, the current instruction finishes normally, the return address (the current value in the program counter) is pushed onto the stack, all of the CPU registers are pushed onto the stack, and execution continues at the address specified by the vector for the interrupt. At the end of the interrupt service routine, an RTI instruction is executed. The RTI instruction causes the saved registers to be pulled off the stack in reverse order. Program execution resumes at the return address.

There are instructions that push and pull the A and B accumulators and the X and Y index registers. These instructions are often used to preserve program context. For example, pushing accumulator A onto the stack when entering a subroutine that uses accumulator A, and then pulling accumulator A off the stack just before leaving the subroutine, ensures that the contents of a register will be the same after returning from the subroutine as it was before starting the subroutine.

3.1.5 Program Counter (PC)

The program counter, a 16-bit register, contains the address of the next instruction to be executed. After reset, the program counter is initialized from one of six possible vectors, depending on operating mode and the cause of reset.

Table 3–1. Reset Vector Comparison

	POR or $\overline{\text{RESET}}$ Pin	Clock Monitor	COP Watchdog
Normal	\$FFFE, F	\$FFFC, D	\$FFFA, B
Test or Boot	\$BFFE, F	\$BFFC, D	\$BFFA, B

3.1.6 Condition Code Register (CCR)

This 8-bit register contains five condition code indicators (C, V, Z, N, and H), two interrupt masking bits (IRQ and XIRQ), and a stop disable bit (S). In the M68HC11 CPU, condition codes are automatically updated by most instructions. For example, load accumulator A (LDAA) and store accumulator A (STAA) instructions automatically set or clear the N, Z, and V condition code

flags. Pushes, pulls, add B to X (ABX), add B to Y (ABY), and transfer/exchange instructions do not affect the condition codes. Refer to Table 3–2, which shows what condition codes are affected by a particular instruction.

3.1.6.1 Carry/Borrow (C)

The C bit is set if the arithmetic logic unit (ALU) performs a carry or borrow during an arithmetic operation. The C bit also acts as an error flag for multiply and divide operations. Shift and rotate instructions operate with and through the carry bit to facilitate multiple-word shift operations.

3.1.6.2 Overflow (V)

The overflow bit is set if an operation causes an arithmetic overflow. Otherwise, the V bit is cleared.

3.1.6.3 Zero (Z)

The Z bit is set if the result of an arithmetic, logic, or data manipulation operation is zero. Otherwise, the Z bit is cleared. Compare instructions do an internal implied subtraction and the condition codes, including Z, reflect the results of that subtraction. A few operations (INX, DEX, INY, and DEY) affect the Z bit and no other condition flags. For these operations, only = and ≠ conditions can be determined.

3.1.6.4 Negative (N)

The N bit is set if the result of an arithmetic, logic, or data manipulation operation is negative (MSB = 1). Otherwise, the N bit is cleared. A result is said to be negative if its most significant bit (MSB) is a one. A quick way to test whether the contents of a memory location has the MSB set is to load it into an accumulator and then check the status of the N bit.

3.1.6.5 Interrupt Mask (I)

The interrupt request (IRQ) mask (I bit) is a global mask that disables all maskable interrupt sources. While the I bit is set, interrupts can become pending, but the operation of the CPU continues uninterrupted until the I bit is cleared. After any reset, the I bit is set by default and can only be cleared by a software instruction. When an interrupt is recognized, the I bit is set after the registers are stacked, but before the interrupt vector is fetched. After the interrupt has been serviced, a return from interrupt instruction is normally executed, restoring the registers to the values that were present before the interrupt occurred. Normally, the I bit is zero after a return from interrupt is executed. Although the I bit can be cleared within an interrupt service routine, "nesting" interrupts in this way should only be done when there is a clear

understanding of latency and of the arbitration mechanism. Refer to **SECTION 5 RESETS AND INTERRUPTS**.

3.1.6.6 Half Carry (H)

The H bit is set when a carry occurs between bits 3 and 4 of the arithmetic logic unit during an ADD, ABA, or ADC instruction. Otherwise, the H bit is cleared. Half carry is used during BCD operations.

3.1.6.7 X Interrupt Mask (X)

The XIRQ mask (X) bit disables interrupts from the $\overline{\text{XIRQ}}$ pin. After any reset, X is set by default and must be cleared by a software instruction. When an $\overline{\text{XIRQ}}$ interrupt is recognized, the X and I bits are set after the registers are stacked, but before the interrupt vector is fetched. After the interrupt has been serviced, an RTI instruction is normally executed, causing the registers to be restored to the values that were present before the interrupt occurred. The X interrupt mask bit is set only by hardware ($\overline{\text{RESET}}$ or $\overline{\text{XIRQ}}$ acknowledge). X is cleared only by program instruction (TAP, where the associated bit of A is 0; or RTI, where bit 6 of the value loaded into the CCR from the stack has been cleared). There is no hardware action for clearing X.

3.1.6.8 Stop Disable (S)

Setting the STOP disable (S) bit prevents the STOP instruction from putting the M68HC11 into a low-power stop condition. If the STOP instruction is encountered by the CPU while the S bit is set, it is treated as a no-operation (NOP) instruction, and processing continues to the next instruction. S is set by reset — STOP disabled by default.

3.2 Data Types

The M68HC11 CPU supports the following data types:

- Bit data
- 8-bit and 16-bit signed and unsigned integers
- 16-bit unsigned fractions
- 16-bit addresses

A byte is eight bits wide and can be accessed at any byte location. A word is composed of two consecutive bytes with the most significant byte at the lower value address. Because the M68HC11 is an 8-bit CPU, there are no special requirements for alignment of instructions or operands.

3.3 Opcodes and Operands

The M68HC11 family of microcontrollers uses 8-bit opcodes. Each opcode identifies a particular instruction and associated addressing mode to the CPU. Several opcodes are required to provide each instruction with a range of addressing capabilities. Only 256 opcodes would be available if the range of values were restricted to the number able to be expressed in 8-bit binary numbers.

A four-page opcode map has been implemented to expand the number of instructions. An additional byte, called a prebyte, directs the processor from page 0 of the opcode map to one of the other three pages. As its name implies, the additional byte precedes the opcode.

A complete instruction consists of a prebyte, if any, an opcode, and zero, one, two, or three operands. The operands contain information the CPU needs for executing the instruction. Complete instructions can be from one to five bytes long.

3.4 Addressing Modes

Six addressing modes; immediate, direct, extended, indexed, inherent, and relative, detailed in the following paragraphs, can be used to access memory. All modes except inherent mode use an effective address. The effective address is the memory address from which the argument is fetched or stored, or the address from which execution is to proceed. The effective address can be specified within an instruction, or it can be calculated.

3.4.1 Immediate

In the immediate addressing mode an argument is contained in the byte(s) immediately following the opcode. The number of bytes following the opcode matches the size of the register or memory location being operated on. There are two-, three-, and four- (if prebyte is required) byte immediate instructions. The effective address is the address of the byte following the instruction.

3.4.2 Direct

In the direct addressing mode, the low-order byte of the operand address is contained in a single byte following the opcode, and the high-order byte of the address is assumed to be \$00. Addresses \$00-\$FF are thus accessed directly, using two-byte instructions. Execution time is reduced by eliminating the additional memory access required for the high-order address byte. In most applications, this 256-byte area is reserved for frequently referenced data. In M68HC11 MCUs, the memory map can be configured for combinations of internal registers, RAM or external memory to occupy these addresses.

3.4.3 Extended

In the extended addressing mode, the effective address of the argument is contained in two bytes following the opcode byte. These are three-byte instructions (or four-byte instructions if a prebyte is required). One or two bytes are needed for the opcode and two for the effective address.

3.4.4 Indexed

In the indexed addressing mode, an 8-bit unsigned offset contained in the instruction is added to the value contained in an index register (IX or IY) — the sum is the effective address. This addressing mode allows referencing any memory location in the 64 Kbyte address space. These are from two- to five-byte instructions, depending on whether or not a prebyte is required.

3.4.5 Inherent

In the inherent addressing mode, all the information necessary to execute the instruction is contained in the opcode. Operations that use only the index registers or accumulators, as well as control instructions with no arguments, are included in this addressing mode. These are one- or two-byte instructions.

3.4.6 Relative

The relative addressing mode is used only for branch instructions. If the branch condition is true, an 8-bit signed offset included in the instruction is added to the contents of the program counter to form the effective branch address. Otherwise, control proceeds to the next instruction. These are usually two-byte instructions.

3.5 Instruction Set

Refer to Table 3–2, which shows all the M68HC11 instructions in all possible addressing modes. For each instruction, the table shows the operand construction, the number of machine code bytes, and execution time in CPU E-clock cycles.

Table 3–2. Instruction Set (1 of 5)

Mnemonic	Operation	Description	Addressing Mode	Instruction			Condition Codes								
				Opcode	Operand	Cycles	S	X	H	I	N	Z	V	C	
ABA	Add Accumulators	$A + B \Rightarrow A$	INH	1B	—	2	—	—	Δ	—	Δ	Δ	Δ	Δ	
ABX	Add B to X	$IX + (00 : B) \Rightarrow IX$	INH	3A	—	3	—	—	—	—	—	—	—	—	
ABY	Add B to Y	$IY + (00 : B) \Rightarrow IY$	INH	18 3A	—	4	—	—	—	—	—	—	—	—	
ADCA (opr)	Add with Carry to A	$A + M + C \Rightarrow A$	A IMM	89	ii	2	—	—	—	Δ	—	Δ	Δ	Δ	Δ
			A DIR	99	dd	3									
			A EXT	B9	hh ll	4									
			A IND,X	A9	ff	4									
			A IND,Y	18 A9	ff	5									
ADCB (opr)	Add with Carry to B	$B + M + C \Rightarrow B$	B IMM	C9	ii	2	—	—	—	Δ	—	Δ	Δ	Δ	Δ
			B DIR	D9	dd	3									
			B EXT	F9	hh ll	4									
			B IND,X	E9	ff	4									
			B IND,Y	18 E9	ff	5									
ADDA (opr)	Add Memory to A	$A + M \Rightarrow A$	A IMM	8B	ii	2	—	—	—	Δ	—	Δ	Δ	Δ	Δ
			A DIR	9B	dd	3									
			A EXT	BB	hh ll	4									
			A IND,X	AB	ff	4									
			A IND,Y	18 AB	ff	5									
ADDB (opr)	Add Memory to B	$B + M \Rightarrow B$	B IMM	CB	ii	2	—	—	—	Δ	—	Δ	Δ	Δ	Δ
			B DIR	DB	dd	3									
			B EXT	FB	hh ll	4									
			B IND,X	EB	ff	4									
			B IND,Y	18 EB	ff	5									
ADDD (opr)	Add 16-Bit to D	$D + (M : M + 1) \Rightarrow D$	IMM	C3	jj kk	4	—	—	—	—	—	Δ	Δ	Δ	Δ
			DIR	D3	dd	5									
			EXT	F3	hh ll	6									
			IND,X	E3	ff	6									
			IND,Y	18 E3	ff	7									
ANDA (opr)	AND A with Memory	$A \cdot M \Rightarrow A$	A IMM	84	ii	2	—	—	—	—	—	Δ	Δ	0	—
			A DIR	94	dd	3									
			A EXT	B4	hh ll	4									
			A IND,X	A4	ff	4									
			A IND,Y	18 A4	ff	5									
ANDB (opr)	AND B with Memory	$B \cdot M \Rightarrow B$	B IMM	C4	ii	2	—	—	—	—	—	Δ	Δ	0	—
			B DIR	D4	dd	3									
			B EXT	F4	hh ll	4									
			B IND,X	E4	ff	4									
			B IND,Y	18 E4	ff	5									
ASL (opr)	Arithmetic Shift Left		EXT	78	hh ll	6	—	—	—	—	—	Δ	Δ	Δ	Δ
			IND,X	68	ff	6									
			IND,Y	18 68	ff	7									
ASLA	Arithmetic Shift Left A		A INH	48	—	2	—	—	—	—	—	Δ	Δ	Δ	Δ
ASLB	Arithmetic Shift Left B		B INH	58	—	2	—	—	—	—	—	Δ	Δ	Δ	Δ
ASLD	Arithmetic Shift Left D		INH	05	—	3	—	—	—	—	—	Δ	Δ	Δ	Δ
ASR	Arithmetic Shift Right		EXT	77	hh ll	6	—	—	—	—	—	Δ	Δ	Δ	Δ
			IND,X	67	ff	6									
			IND,Y	18 67	ff	7									
ASRA	Arithmetic Shift Right A		A INH	47	—	2	—	—	—	—	—	Δ	Δ	Δ	Δ
ASRB	Arithmetic Shift Right B		B INH	57	—	2	—	—	—	—	—	Δ	Δ	Δ	Δ
BCC (rel)	Branch if Carry Clear	? C = 0	REL	24	rr	3	—	—	—	—	—	—	—	—	—
BCLR (opr) (msk)	Clear Bit(s)	$M \cdot (\overline{mm}) \Rightarrow M$	DIR	15	dd mm	6	—	—	—	—	—	Δ	Δ	0	—
			IND,X	1D	ff mm	7									
			IND,Y	18 1D	ff mm	8									
BCS (rel)	Branch if Carry Set	? C = 1	REL	25	rr	3	—	—	—	—	—	—	—	—	—
BEQ (rel)	Branch if = Zero	? Z = 1	REL	27	rr	3	—	—	—	—	—	—	—	—	—
BGE (rel)	Branch if ≥ Zero	? N ⊕ V = 0	REL	2C	rr	3	—	—	—	—	—	—	—	—	—
BGT (rel)	Branch if > Zero	? Z + (N ⊕ V) = 0	REL	2E	rr	3	—	—	—	—	—	—	—	—	—
BHI (rel)	Branch if Higher	? C + Z = 0	REL	22	rr	3	—	—	—	—	—	—	—	—	—
BHS (rel)	Branch if Higher or Same	? C = 0	REL	24	rr	3	—	—	—	—	—	—	—	—	—
BITA (opr)	Bit(s) Test A with Memory	A · M	A IMM	85	ii	2	—	—	—	—	—	Δ	Δ	0	—
			A DIR	95	dd	3									
			A EXT	B5	hh ll	4									
			A IND,X	A5	ff	4									
			A IND,Y	18 A5	ff	5									
BITB (opr)	Bit(s) Test B with Memory	B · M	B IMM	C5	ii	2	—	—	—	—	—	Δ	Δ	0	—
			B DIR	D5	dd	3									
			B EXT	F5	hh ll	4									
			B IND,X	E5	ff	4									
			B IND,Y	18 E5	ff	5									

Table 3–2. Instruction Set (2 of 5)

Mnemonic	Operation	Description	Addressing Mode	Instruction			Condition Codes									
				Opcode	Operand	Cycles	S	X	H	I	N	Z	V	C		
BLE (rel)	Branch if ≤ Zero	? Z + (N ⊕ V) = 1	REL	2F	rr	3	—	—	—	—	—	—	—	—	—	—
BLO (rel)	Branch if Lower	? C = 1	REL	25	rr	3	—	—	—	—	—	—	—	—	—	—
BLS (rel)	Branch if Lower or Same	? C + Z = 1	REL	23	rr	3	—	—	—	—	—	—	—	—	—	—
BLT (rel)	Branch if < Zero	? N ⊕ V = 1	REL	2D	rr	3	—	—	—	—	—	—	—	—	—	—
BMI (rel)	Branch if Minus	? N = 1	REL	2B	rr	3	—	—	—	—	—	—	—	—	—	—
BNE (rel)	Branch if not = Zero	? Z = 0	REL	26	rr	3	—	—	—	—	—	—	—	—	—	—
BPL (rel)	Branch if Plus	? N = 0	REL	2A	rr	3	—	—	—	—	—	—	—	—	—	—
BRA (rel)	Branch Always	? 1 = 1	REL	20	rr	3	—	—	—	—	—	—	—	—	—	—
BRCLR(opr) (msk) (rel)	Branch if Bit(s) Clear	? M • mm = 0	DIR IND,X IND,Y	13 1F 18 1F	dd mm rr ff mm rr ff mm rr	6 7 8	—	—	—	—	—	—	—	—	—	—
BRN (rel)	Branch Never	? 1 = 0	REL	21	rr	3	—	—	—	—	—	—	—	—	—	—
BRSET(opr) (msk) (rel)	Branch if Bit(s) Set	? (M̄) • mm = 0	DIR IND,X IND,Y	12 1E 18 1E	dd mm rr ff mm rr ff mm rr	6 7 8	—	—	—	—	—	—	—	—	—	—
BSET (opr) (msk)	Set Bit(s)	M + mm ⇒ M	DIR IND,X IND,Y	14 1C 18 1C	dd mm ff mm ff mm	6 7 8	—	—	—	—	Δ	Δ	0	—	—	—
BSR (rel)	Branch to Subroutine	See Figure 3-2	REL	8D	rr	6	—	—	—	—	—	—	—	—	—	—
BVC (rel)	Branch if Overflow Clear	? V = 0	REL	28	rr	3	—	—	—	—	—	—	—	—	—	—
BVS (rel)	Branch if Overflow Set	? V = 1	REL	29	rr	3	—	—	—	—	—	—	—	—	—	—
CBA	Compare A to B	A – B	INH	11	—	2	—	—	—	—	Δ	Δ	Δ	Δ	—	—
CLC	Clear Carry Bit	0 ⇒ C	INH	0C	—	2	—	—	—	—	—	—	—	—	0	—
CLI	Clear Interrupt Mask	0 ⇒ 1	INH	0E	—	2	—	—	—	0	—	—	—	—	—	—
CLR (opr)	Clear Memory Byte	0 ⇒ M	EXT IND,X IND,Y	7F 6F 18 6F	hh ll ff ff	6 6 7	—	—	—	—	0	1	0	0	—	—
CLRA	Clear Accumulator A	0 ⇒ A	A INH	4F	—	2	—	—	—	—	0	1	0	0	—	—
CLRB	Clear Accumulator B	0 ⇒ B	B INH	5F	—	2	—	—	—	—	0	1	0	0	—	—
CLV	Clear Overflow Flag	0 ⇒ V	INH	0A	—	2	—	—	—	—	—	—	0	—	—	—
CMPA (opr)	Compare A to Memory	A – M	A IMM A DIR A EXT A IND,X A IND,Y	81 91 B1 A1 18 A1	ii dd hh ll ff ff	2 3 4 4 5	—	—	—	—	Δ	Δ	Δ	Δ	—	—
CMPB (opr)	Compare B to Memory	B – M	B IMM B DIR B EXT B IND,X B IND,Y	C1 D1 F1 E1 18 E1	ii dd hh ll ff ff	2 3 4 4 5	—	—	—	—	Δ	Δ	Δ	Δ	—	—
COM (opr)	Ones Complement Memory Byte	\$FF – M ⇒ M	EXT IND,X IND,Y	73 63 18 63	hh ll ff ff	6 6 7	—	—	—	—	Δ	Δ	0	1	—	—
COMA	Ones Complement A	\$FF – A ⇒ A	A INH	43	—	2	—	—	—	—	Δ	Δ	0	1	—	—
COMB	Ones Complement B	\$FF – B ⇒ B	B INH	53	—	2	—	—	—	—	Δ	Δ	0	1	—	—
CPD (opr)	Compare D to Memory 16-Bit	D – M : M + 1	IMM DIR EXT IND,X IND,Y	1A 83 1A 93 1A B3 1A A3 CD A3	jj kk dd hh ll ff ff	5 6 7 7 7	—	—	—	—	Δ	Δ	Δ	Δ	—	—
CPX (opr)	Compare X to Memory 16-Bit	IX – M : M + 1	IMM DIR EXT IND,X IND,Y	8C 9C BC AC CD AC	jj kk dd hh ll ff ff	4 5 6 6 7	—	—	—	—	Δ	Δ	Δ	Δ	—	—
CPY (opr)	Compare Y to Memory 16-Bit	IY – M : M + 1	IMM DIR EXT IND,X IND,Y	18 8C 18 9C 18 BC 1A AC 18 AC	jj kk dd hh ll ff ff	5 6 7 7 7	—	—	—	—	Δ	Δ	Δ	Δ	—	—
DAA	Decimal Adjust A	Adjust Sum to BCD	INH	19	—	2	—	—	—	—	Δ	Δ	Δ	Δ	—	—
DEC (opr)	Decrement Memory Byte	M – 1 ⇒ M	EXT IND,X IND,Y	7A 6A 18 6A	hh ll ff ff	6 6 7	—	—	—	—	Δ	Δ	Δ	—	—	—
DECA	Decrement Accumulator A	A – 1 ⇒ A	A INH	4A	—	2	—	—	—	—	Δ	Δ	Δ	—	—	—
DECB	Decrement Accumulator B	B – 1 ⇒ B	B INH	5A	—	2	—	—	—	—	Δ	Δ	Δ	—	—	—
DES	Decrement Stack Pointer	SP – 1 ⇒ SP	INH	34	—	3	—	—	—	—	—	—	—	—	—	—
DEX	Decrement Index Register X	IX – 1 ⇒ IX	INH	09	—	3	—	—	—	—	—	Δ	—	—	—	—
DEY	Decrement Index Register Y	IY – 1 ⇒ IY	INH	18 09	—	4	—	—	—	—	—	Δ	—	—	—	—

Table 3–2. Instruction Set (3 of 5)

Mnemonic	Operation	Description	Addressing Mode	Instruction			Condition Codes							
				Opcode	Operand	Cycles	S	X	H	I	N	Z	V	C
EORA (opr)	Exclusive OR A with Memory	$A \oplus M \Rightarrow A$	A IMM	88	ii	2	—	—	—	—	—	—	—	—
			A DIR	98	dd	3								
			A EXT	B8	hh ll	4								
			A IND,X	A8	ff	4								
			A IND,Y	18 A8	ff	5								
EORB (opr)	Exclusive OR B with Memory	$B \oplus M \Rightarrow B$	B IMM	C8	ii	2	—	—	—	—	—	—	—	—
			B DIR	D8	dd	3								
			B EXT	F8	hh ll	4								
			B IND,X	E8	ff	4								
			B IND,Y	18 E8	ff	5								
FDIV	Fractional Divide 16 by 16	$D / IX \Rightarrow IX; r \Rightarrow D$	INH	03	—	41	—	—	—	—	—	—	—	—
IDIV	Integer Divide 16 by 16	$D / IX \Rightarrow IX; r \Rightarrow D$	INH	02	—	41	—	—	—	—	—	—	—	—
INC (opr)	Increment Memory Byte	$M + 1 \Rightarrow M$	EXT	7C	hh ll	6	—	—	—	—	—	—	—	—
			IND,X	6C	ff	6								
			IND,Y	18 6C	ff	7								
INCA	Increment Accumulator A	$A + 1 \Rightarrow A$	A INH	4C	—	2	—	—	—	—	—	—	—	—
INCB	Increment Accumulator B	$B + 1 \Rightarrow B$	B INH	5C	—	2	—	—	—	—	—	—	—	—
INS	Increment Stack Pointer	$SP + 1 \Rightarrow SP$	INH	31	—	3	—	—	—	—	—	—	—	—
INX	Increment Index Register X	$IX + 1 \Rightarrow IX$	INH	08	—	3	—	—	—	—	—	—	—	—
INY	Increment Index Register Y	$IY + 1 \Rightarrow IY$	INH	18 08	—	4	—	—	—	—	—	—	—	—
JMP (opr)	Jump	See Figure 3-2	EXT	7E	hh ll	3	—	—	—	—	—	—	—	—
			IND,X	6E	ff	3								
			IND,Y	18 6E	ff	4								
JSR (opr)	Jump to Subroutine	See Figure 3-2	DIR	9D	dd	5	—	—	—	—	—	—	—	—
			EXT	BD	hh ll	6								
			IND,X	AD	ff	6								
			IND,Y	18 AD	ff	7								
LDAA (opr)	Load Accumulator A	$M \Rightarrow A$	A IMM	86	ii	2	—	—	—	—	—	—	—	—
			A DIR	96	dd	3								
			A EXT	B6	hh ll	4								
			A IND,X	A6	ff	4								
			A IND,Y	18 A6	ff	5								
LDAB (opr)	Load Accumulator B	$M \Rightarrow B$	B IMM	C6	ii	2	—	—	—	—	—	—	—	—
			B DIR	D6	dd	3								
			B EXT	F6	hh ll	4								
			B IND,X	E6	ff	4								
			B IND,Y	18 E6	ff	5								
LDD (opr)	Load Double Accumulator D	$M \Rightarrow A, M + 1 \Rightarrow B$	IMM	CC	jj kk	3	—	—	—	—	—	—	—	—
			DIR	DC	dd	4								
			EXT	FC	hh ll	5								
			IND,X	EC	ff	5								
			IND,Y	18 EC	ff	6								
LDS (opr)	Load Stack Pointer	$M : M + 1 \Rightarrow SP$	IMM	8E	jj kk	3	—	—	—	—	—	—	—	—
			DIR	9E	dd	4								
			EXT	BE	hh ll	5								
			IND,X	AE	ff	5								
			IND,Y	18 AE	ff	6								
LDX (opr)	Load Index Register X	$M : M + 1 \Rightarrow IX$	IMM	CE	jj kk	3	—	—	—	—	—	—	—	—
			DIR	DE	dd	4								
			EXT	FE	hh ll	5								
			IND,X	EE	ff	5								
			IND,Y	CD EE	ff	6								
LDY (opr)	Load Index Register Y	$M : M + 1 \Rightarrow IY$	IMM	18 CE	jj kk	4	—	—	—	—	—	—	—	—
			DIR	18 DE	dd	5								
			EXT	18 FE	hh ll	6								
			IND,X	1A EE	ff	6								
			IND,Y	18 EE	ff	6								
LSL (opr)	Logical Shift Left		EXT	78	hh ll	6	—	—	—	—	—	—	—	—
			IND,X	68	ff	6								
			IND,Y	18 68	ff	7								
LSLA	Logical Shift Left A		A INH	48	—	2	—	—	—	—	—	—	—	—
LSLB	Logical Shift Left B		B INH	58	—	2	—	—	—	—	—	—	—	—
LSLD	Logical Shift Left Double		INH	05	—	3	—	—	—	—	—	—	—	—
LSR (opr)	Logical Shift Right		EXT	74	hh ll	6	—	—	—	—	0	—	—	—
			IND,X	64	ff	6								
			IND,Y	18 64	ff	7								
LSRA	Logical Shift Right A		A INH	44	—	2	—	—	—	—	0	—	—	—

Table 3–2. Instruction Set (4 of 5)

Mnemonic	Operation	Description	Addressing Mode	Instruction			Condition Codes								
				Opcode	Operand	Cycles	S	X	H	I	N	Z	V	C	
LSRB	Logical Shift Right B		B INH	54	—	2	—	—	—	—	—	0	Δ	Δ	Δ
LSRD	Logical Shift Right Double		INH	04	—	3	—	—	—	—	—	0	Δ	Δ	Δ
MUL	Multiply 8 by 8	$A * B \Rightarrow D$	INH	3D	—	10	—	—	—	—	—	—	—	—	Δ
NEG (opr)	Twos Complement Memory Byte	$0 - M \Rightarrow M$	EXT IND,X IND,Y	70 60 18 60	hh ll ff ff	6 6 7	—	—	—	—	—	Δ	Δ	Δ	Δ
NEGA	Twos Complement A	$0 - A \Rightarrow A$	A INH	40	—	2	—	—	—	—	—	Δ	Δ	Δ	Δ
NEGB	Twos Complement B	$0 - B \Rightarrow B$	B INH	50	—	2	—	—	—	—	—	Δ	Δ	Δ	Δ
NOP	No operation	No Operation	INH	01	—	2	—	—	—	—	—	—	—	—	—
ORAA (opr)	OR Accumulator A (Inclusive)	$A + M \Rightarrow A$	A IMM A DIR A EXT A IND,X A IND,Y	8A 9A BA AA 18 AA	ii dd hh ll ff ff	2 3 4 4 5	—	—	—	—	—	Δ	Δ	0	—
ORAB (opr)	OR Accumulator B (Inclusive)	$B + M \Rightarrow B$	B IMM B DIR B EXT B IND,X B IND,Y	CA DA FA EA 18 EA	ii dd hh ll ff ff	2 3 4 4 5	—	—	—	—	—	Δ	Δ	0	—
PSHA	Push A onto Stack	$A \Rightarrow \text{Stk}, SP = SP - 1$	A INH	36	—	3	—	—	—	—	—	—	—	—	—
PSHB	Push B onto Stack	$B \Rightarrow \text{Stk}, SP = SP - 1$	B INH	37	—	3	—	—	—	—	—	—	—	—	—
PSHX	Push X onto Stack (Lo First)	$IX \Rightarrow \text{Stk}, SP = SP - 2$	INH	3C	—	4	—	—	—	—	—	—	—	—	—
PSHY	Push Y onto Stack (Lo First)	$IY \Rightarrow \text{Stk}, SP = SP - 2$	INH	18 3C	—	5	—	—	—	—	—	—	—	—	—
PULA	Pull A from Stack	$SP = SP + 1, A \Leftarrow \text{Stk}$	A INH	32	—	4	—	—	—	—	—	—	—	—	—
PULB	Pull B from Stack	$SP = SP + 1, B \Leftarrow \text{Stk}$	B INH	33	—	4	—	—	—	—	—	—	—	—	—
PULX	Pull X From Stack (Hi First)	$SP = SP + 2, IX \Leftarrow \text{Stk}$	INH	38	—	5	—	—	—	—	—	—	—	—	—
PULY	Pull Y from Stack (Hi First)	$SP = SP + 2, IY \Leftarrow \text{Stk}$	INH	18 38	—	6	—	—	—	—	—	—	—	—	—
ROL (opr)	Rotate Left		EXT IND,X IND,Y	79 69 18 69	hh ll ff ff	6 6 7	—	—	—	—	—	Δ	Δ	Δ	Δ
ROLA	Rotate Left A		A INH	49	—	2	—	—	—	—	—	Δ	Δ	Δ	Δ
ROLB	Rotate Left B		B INH	59	—	2	—	—	—	—	—	Δ	Δ	Δ	Δ
ROR (opr)	Rotate Right		EXT IND,X IND,Y	76 66 18 66	hh ll ff ff	6 6 7	—	—	—	—	—	Δ	Δ	Δ	Δ
RORA	Rotate Right A		A INH	46	—	2	—	—	—	—	—	Δ	Δ	Δ	Δ
RORB	Rotate Right B		B INH	56	—	2	—	—	—	—	—	Δ	Δ	Δ	Δ
RTI	Return from Interrupt	See Figure 3-2	INH	3B	—	12	Δ	↓	Δ	Δ	—	Δ	Δ	Δ	Δ
RTS	Return from Subroutine	See Figure 3-2	INH	39	—	5	—	—	—	—	—	—	—	—	—
SBA	Subtract B from A	$A - B \Rightarrow A$	INH	10	—	2	—	—	—	—	—	Δ	Δ	Δ	Δ
SBCA (opr)	Subtract with Carry from A	$A - M - C \Rightarrow A$	A IMM A DIR A EXT A IND,X A IND,Y	82 92 B2 A2 18 A2	ii dd hh ll ff ff	2 3 4 4 5	—	—	—	—	—	Δ	Δ	Δ	Δ
SBCB (opr)	Subtract with Carry from B	$B - M - C \Rightarrow B$	B IMM B DIR B EXT B IND,X B IND,Y	C2 D2 F2 E2 18 E2	ii dd hh ll ff ff	2 3 4 4 5	—	—	—	—	—	Δ	Δ	Δ	Δ
SEC	Set Carry	$1 \Rightarrow C$	INH	0D	—	2	—	—	—	—	—	—	—	—	1
SEI	Set Interrupt Mask	$1 \Rightarrow I$	INH	0F	—	2	—	—	—	1	—	—	—	—	—
SEV	Set Overflow Flag	$1 \Rightarrow V$	INH	0B	—	2	—	—	—	—	—	—	—	1	—
STAA (opr)	Store Accumulator A	$A \Rightarrow M$	A DIR A EXT A IND,X A IND,Y	97 B7 A7 18 A7	dd hh ll ff ff	3 4 4 5	—	—	—	—	—	Δ	Δ	0	—
STAB (opr)	Store Accumulator B	$B \Rightarrow M$	B DIR B EXT B IND,X B IND,Y	D7 F7 E7 18 E7	dd hh ll ff ff	3 4 4 5	—	—	—	—	—	Δ	Δ	0	—

Table 3–2. Instruction Set (5 of 5)

Mnemonic	Operation	Description	Addressing Mode	Instruction			Condition Codes								
				Opcode	Operand	Cycles	S	X	H	I	N	Z	V	C	
STD (opr)	Store Accumulator D	A ⇒ M, B ⇒ M + 1	DIR	DD	dd	4	—	—	—	—	—	—	—	—	—
			EXT	FD	hh ll	5	—	—	—	—	—	—	—	—	
			IND,X	ED	ff	5	—	—	—	—	—	—	—	—	
			IND,Y	18 ED	ff	6	—	—	—	—	—	—	—	—	
STOP	Stop Internal Clocks	—	INH	CF	—	2	—	—	—	—	—	—	—	—	
STS (opr)	Store Stack Pointer	SP ⇒ M : M + 1	DIR	9F	dd	4	—	—	—	—	—	—	—	—	
			EXT	BF	hh ll	5	—	—	—	—	—	—	—		
			IND,X	AF	ff	5	—	—	—	—	—	—	—		
			IND,Y	18 AF	ff	6	—	—	—	—	—	—	—		
STX (opr)	Store Index Register X	IX ⇒ M : M + 1	DIR	DF	dd	4	—	—	—	—	—	—	—	—	
			EXT	FF	hh ll	5	—	—	—	—	—	—	—		
			IND,X	EF	ff	5	—	—	—	—	—	—	—		
			IND,Y	CD EF	ff	6	—	—	—	—	—	—	—		
STY (opr)	Store Index Register Y	IY ⇒ M : M + 1	DIR	18 DF	dd	5	—	—	—	—	—	—	—	—	
			EXT	18 FF	hh ll	6	—	—	—	—	—	—	—		
			IND,X	1A EF	ff	6	—	—	—	—	—	—	—		
			IND,Y	18 EF	ff	6	—	—	—	—	—	—	—		
SUBA (opr)	Subtract Memory from A	A – M ⇒ A	A IMM	80	ii	2	—	—	—	—	—	—	—	—	
			A DIR	90	dd	3	—	—	—	—	—	—	—		
			A EXT	B0	hh ll	4	—	—	—	—	—	—	—		
			A IND,X	A0	ff	4	—	—	—	—	—	—	—		
			A IND,Y	18 A0	ff	5	—	—	—	—	—	—	—		
SUBB (opr)	Subtract Memory from B	B – M ⇒ B	A IMM	C0	ii	2	—	—	—	—	—	—	—	—	
			A DIR	D0	dd	3	—	—	—	—	—	—	—		
			A EXT	F0	hh ll	4	—	—	—	—	—	—	—		
			A IND,X	E0	ff	4	—	—	—	—	—	—	—		
			A IND,Y	18 E0	ff	5	—	—	—	—	—	—	—		
SUBD (opr)	Subtract Memory from D	D – M : M + 1 ⇒ D	IMM	83	jj kk	4	—	—	—	—	—	—	—	—	
			DIR	93	dd	5	—	—	—	—	—	—	—		
			EXT	B3	hh ll	6	—	—	—	—	—	—	—		
			IND,X	A3	ff	6	—	—	—	—	—	—	—		
			IND,Y	18 A3	ff	7	—	—	—	—	—	—	—		
SWI	Software Interrupt	See Figure 3-2	INH	3F	—	14	—	—	—	—	—	—	—		
TAB	Transfer A to B	A ⇒ B	INH	16	—	2	—	—	—	—	—	—	—		
TAP	Transfer A to CC Register	A ⇒ CCR	INH	06	—	2	Δ	↓	Δ	Δ	Δ	Δ	Δ		
TBA	Transfer B to A	B ⇒ A	INH	17	—	2	—	—	—	—	—	—	—		
TEST	TEST (Only in Test Modes)	Address Bus Counts	INH	00	—	*	—	—	—	—	—	—	—		
TPA	Transfer CC Register to A	CCR ⇒ A	INH	07	—	2	—	—	—	—	—	—	—		
TST (opr)	Test for Zero or Minus	M – 0	EXT	7D	hh ll	6	—	—	—	—	—	—	—		
			IND,X	6D	ff	6	—	—	—	—	—	—			
			IND,Y	18 6D	ff	7	—	—	—	—	—	—			
TSTA	Test A for Zero or Minus	A – 0	A INH	4D	—	2	—	—	—	—	—	—			
TSTB	Test B for Zero or Minus	B – 0	B INH	5D	—	2	—	—	—	—	—	—			
TSX	Transfer Stack Pointer to X	SP + 1 ⇒ IX	INH	30	—	3	—	—	—	—	—	—			
TSY	Transfer Stack Pointer to Y	SP + 1 ⇒ IY	INH	18 30	—	4	—	—	—	—	—	—			
TXS	Transfer X to Stack Pointer	IX – 1 ⇒ SP	INH	35	—	3	—	—	—	—	—	—			
TYS	Transfer Y to Stack Pointer	IY – 1 ⇒ SP	INH	18 35	—	4	—	—	—	—	—	—			
WAI	Wait for Interrupt	Stack Regs & WAIT	INH	3E	—	**	—	—	—	—	—	—			
XGDY	Exchange D with X	IX ⇒ D, D ⇒ IX	INH	8F	—	3	—	—	—	—	—	—			
XGDX	Exchange D with Y	IY ⇒ D, D ⇒ IY	INH	18 8F	—	4	—	—	—	—	—	—			

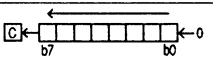
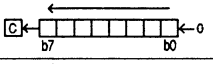
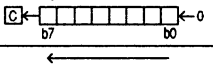
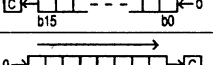
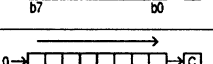
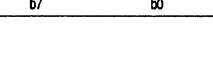
Cycle

- * Infinity or until reset occurs
- ** 12 Cycles are used beginning with the opcode fetch. A wait state is entered which remains in effect for an integer number of MPU E-Clock cycles (n) until an interrupt is recognized. Finally, two additional cycles are used to fetch the appropriate interrupt vector (14 + n total).

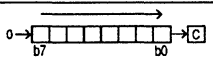
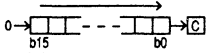
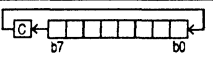
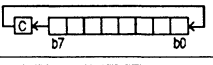
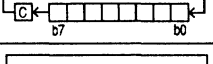
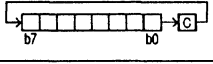
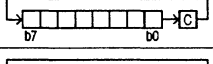
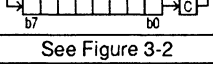
Operands

- dd = 8-Bit Direct Address (\$0000 - \$00FF) (High Byte Assumed to be \$00)
- ff = 8-Bit Positive Offset \$00 (0) to \$FF (255) (Is Added to Index)
- hh = High-Order Byte of 16-Bit Extended Address
- ii = One Byte of Immediate Data
- jj = High-Order Byte of 16-Bit Immediate Data
- kk = Low-Order Byte of 16-Bit Immediate Data
- ll = Low-Order Byte of 16-Bit Extended Address
- mm = 8-Bit Mask (Set Bits to be Affected)
- rr = Signed Relative Offset \$80 (– 128) to \$7F (+ 127)
(Offset Relative to Address Following Machine Code Offset Byte)

Operators

- () Contents of register shown inside parentheses
- ⇐ Is transferred to
- ↑ Is pulled from stack
- ↓ Is pushed onto stack
- Boolean AND
- + Arithmetic Addition Symbol except where used as Inclusive-OR symbol in Boolean Formula
- ⊕ Exclusive-OR
- * Multiply
- : Concatenation
- Arithmetic subtraction symbol or Negation symbol (Twos Complement)

Condition Codes

- Bit not changed
- 0 Bit always cleared
- 1 Bit always set
- Δ Bit cleared or set, depending on operation
- ↓ Bit can be cleared, cannot become set

SECTION 4 OPERATING MODES AND ON-CHIP MEMORY

Section 4 contains information about the modes that define MC68HC711L6 operating conditions, and about the on-chip memory that allows the MCU to be configured for various applications.

4.1 Operating Modes

The values of the mode select inputs MODB and MODA during reset determine the operating mode. Single-chip and expanded multiplexed are the normal modes. With single-chip mode only on-board memory is available. Expanded multiplexed mode, however, allows access to external memory. Each of these two normal modes is paired with a special mode. Bootstrap, a variation of the single-chip mode, is a special mode that executes a bootloader program in an internal bootstrap ROM. Test is a special mode that allows privileged access to internal resources.

4.1.1 Single-Chip Mode

In single-chip mode ports B and C and strobe pins A (STRA) and B (STRB) are available for general-purpose parallel I/O. In expanded multiplexed mode the MCU can access a 64 Kbyte address space. The total address space includes the same on-chip memory addresses used for single-chip mode plus external memory and peripheral devices.

4.1.2 Expanded Multiplexed Mode

Expanded memory access is achieved by providing multiplexed external data and address buses on two of the M68HC11 ports; therefore only 18 pins are needed for an 8-bit data bus, a 16-bit address bus and two bus control lines. Port B is designated for A[15:8], while port C is multiplexed A[7:0]/D[7:0]. The address, $\overline{R/W}$, and AS signals are active and valid for all bus cycles including accesses to internal memory locations. Refer to Figure 4–1, which illustrates a recommended method of demultiplexing low order addresses from data at port C.

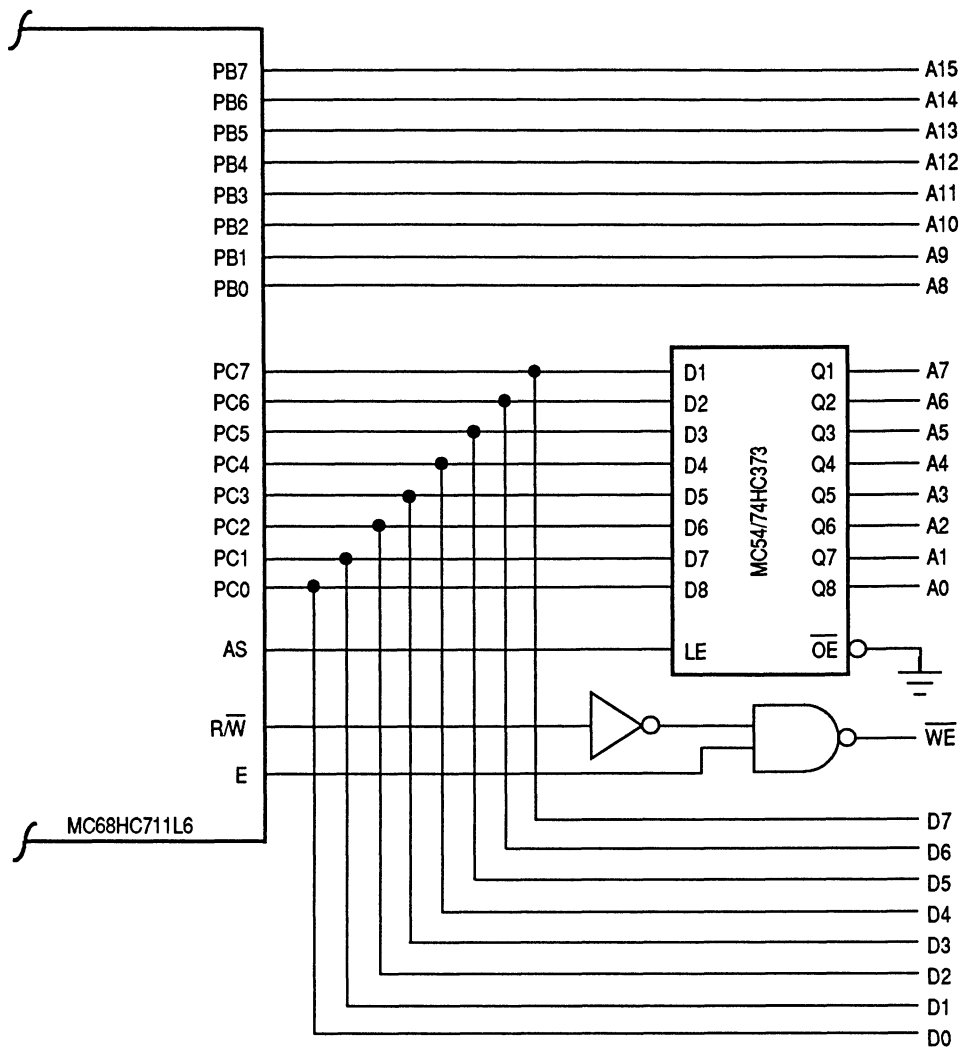

Figure 4–1. Address/Data Demultiplexing

4.1.3 Special Test Mode

Special test, a variation of the expanded multiplexed mode, is primarily used during Motorola's internal production testing; however, it is accessible for programming the CONFIG register, programming calibration data into EEPROM, and supporting emulation and debugging during development.

4.1.4 Bootstrap Mode

When the MCU is reset in special bootstrap mode, a small amount of on-chip ROM is enabled at address \$BF00–\$BFFF. The ROM contains a bootloader program and a special set of interrupt and reset vectors. The MCU fetches the reset vector, then executes the bootloader.

For normal use of the bootloader program, send \$FF to the SCI receiver at either E clock ÷16, or E clock ÷104 (1200 baud for E clock equals 2 MHz). Then

download up to 512 bytes of program data, which is put into RAM starting at \$0000 and continuing through \$01FF. These characters are echoed through the transmitter. When loading is complete, the program jumps to location \$0000 and begins executing the code. The bootloader program ends the download after 512 bytes, or when the received data line is idle for at least four character times. Use of an external pullup resistor is required when using the SCI transmitter pin because port D pins are configured for wire-OR operation by the bootloader. In bootstrap mode, the interrupt vectors are directed to RAM. This allows the use of interrupts through a jump table. Refer to Motorola application note AN1060, *MC68HC11 Bootstrap Mode*.

4.2 Memory Map

The operating mode determines memory mapping and whether memory is addressed on- or off-chip. Refer to Figure 4–2, which illustrates the memory maps for each of the four modes of operation. Memory locations for on-chip resources are the same for both expanded multiplexed and single-chip modes. Control bits in the CONFIG register allow EPROM and EEPROM to be disabled from the memory map. The 512-byte RAM is mapped to \$0000 after reset. It can be placed at any other 4K boundary (\$x000) by writing an appropriate value to the INIT register. The 64-byte register block is mapped to \$1000 after reset and can also be placed at any 4K boundary (\$x000) by writing an appropriate value to the INIT register. Refer to Table 4–1, which details the MCU register and control bit assignments.

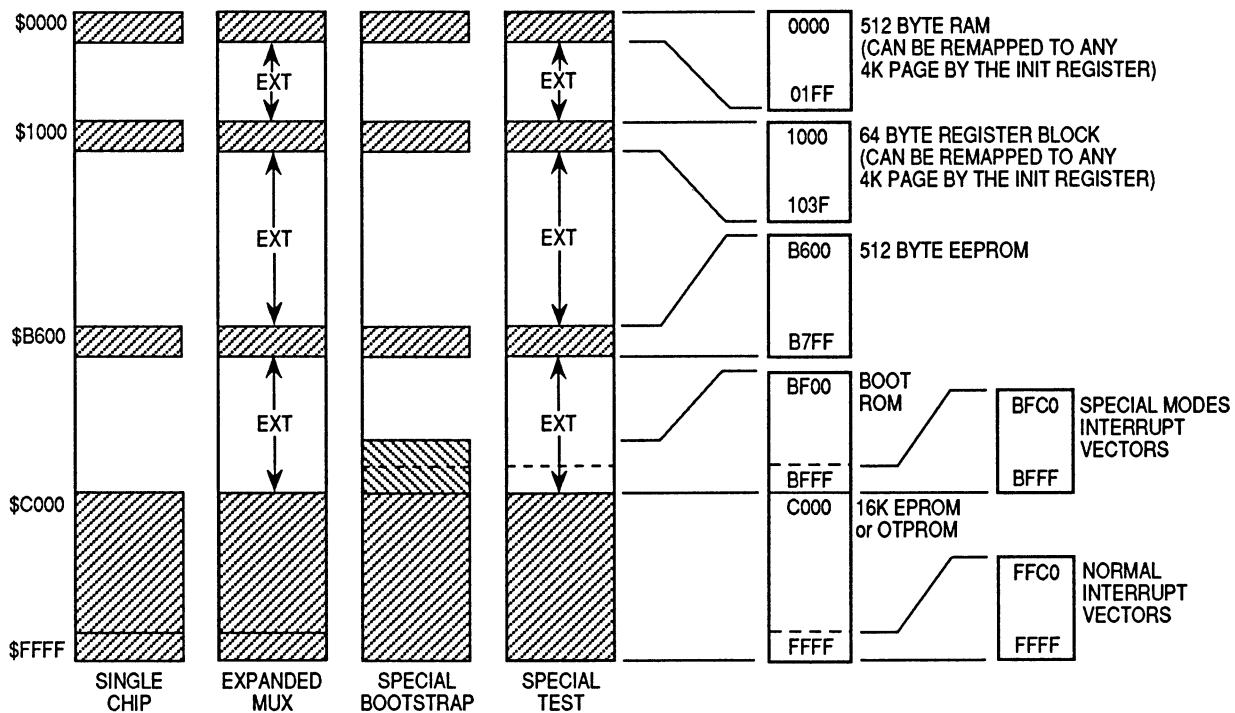

Figure 4–2. Memory Map

Table 4–1. Register and Control Bit Assignments (1 of 2)

The register block can be remapped to any 4K boundary

	Bit 7	6	5	4	3	2	1	Bit 0	
\$1000	PA7	PA6	PA5	PA4	PA3	PA2	PA1	PA0	PORTA
\$1001									Reserved
\$1002	STAF	STAI	CWOM	HNDS	OIN	PLS	EGA	INVB	PIOC
\$1003	PC7	PC6	PC5	PC4	PC3	PC2	PC1	PC0	PORTC
\$1004	PB7	PB6	PB5	PB4	PB3	PB2	PB1	PB0	PORTB
\$1005	PCL7	PCL6	PCL5	PCL4	PCL3	PCL2	PCL1	PCL0	PORTCL
\$1006									Reserved
\$1007	DDC7	DDC6	DDC5	DDC4	DDC3	DDC2	DDC1	DDC0	DDRC
\$1008	0	0	PD5	PD4	PD3	PD2	PD1	PD0	PORTD
\$1009	0	0	DDD5	DDD4	DDD3	DDD2	DDD1	DDD0	DDRD
\$100A	PE7	PE6	PE5	PE4	PE3	PE2	PE1	PE0	PORTE
\$100B	FOC1	FOC2	FOC3	FOC4	FOC5	0	0	0	CFORC
\$100C	OC1M7	OC1M6	OC1M5	OC1M4	OC1M3	0	0	0	OC1M
\$100D	OC1D7	OC1D6	OC1D5	OC1D4	OC1D3	0	0	0	OC1D
\$100E	Bit 15	14	13	12	11	10	9	Bit 8	TCNT (High)
\$100F	Bit 7	6	5	4	3	2	1	Bit 0	TCNT (Low)
\$1010	Bit 15	14	13	12	11	10	9	Bit 8	TIC1 (High)
\$1011	Bit 7	6	5	4	3	2	1	Bit 0	TIC1 (Low)
\$1012	Bit 15	14	13	12	11	10	9	Bit 8	TIC2 (High)
\$1013	Bit 7	6	5	4	3	2	1	Bit 0	TIC2 (Low)
\$1014	Bit 15	14	13	12	11	10	9	Bit 8	TIC3 (High)
\$1015	Bit 7	6	5	4	3	2	1	Bit 0	TIC3 (Low)
\$1016	Bit 15	14	13	12	11	10	9	Bit 8	TOC1(High)
\$1017	Bit 7	6	5	4	3	2	1	Bit 0	TOC1 (Low)
\$1018	Bit 15	14	13	12	11	10	9	Bit 8	TOC2 (High)
\$1019	Bit 7	6	5	4	3	2	1	Bit 0	TOC2 (Low)
\$101A	Bit 15	14	13	12	11	10	9	Bit 8	TOC3 (High)
\$101B	Bit 7	6	5	4	3	2	1	Bit 0	TOC3 (Low)
\$101C	Bit 15	14	13	12	11	10	9	Bit 8	TOC4 (High)
\$101D	Bit 7	6	5	4	3	2	1	Bit 0	TOC4 (Low)
\$101E	Bit 15	14	13	12	11	10	9	Bit 8	TI4/O5 (High)
\$101F	Bit 7	6	5	4	3	2	1	Bit 0	TI4/O5 (Low)
\$1020	OM2	OL2	OM3	OL3	OM4	OL4	OM5	OL5	TCTL1
\$1021	EDG4B	EDG4A	EDG1B	EDG1A	EDG2B	EDG2A	EDG3B	EDG3A	TCTL2

Table 4–1. Register and Control Bit Assignments (2 of 2)

\$1022	OC1I	OC2I	OC3I	OC4I	I4O5I	IC1I	IC2I	IC3I	TMSK1
\$1023	OC1F	OC2F	OC3F	OC4F	I4O5F	IC1F	IC2F	IC3F	TFLG1
\$1024	TOI	RTII	PAOVI	PAII	0	0	PR1	PR0	TMSK2
\$1025	TOF	RTIF	PAOVF	PAIF	0	0	0	0	TFLG2
\$1026	DDRA7	PAEN	PAMOD	PEDGE	DDRA3	I4/O5	RTR1	RTR0	PACTL
\$1027	Bit 7	6	5	4	3	2	1	Bit 0	PACNT
\$1028	SPIE	SPE	DWOM	MSTR	CPOL	CPHA	SPR1	SPR0	SPCR
\$1029	SPIF	WCOL	0	MODF	0	0	0	0	SPSR
\$102A	Bit 7	6	5	4	3	2	1	Bit 0	SPDR
\$102B	TCLR	0	SCP1	SCP0	RCKB	SCR2	SCR1	SCR0	BAUD
\$102C	R8	T8	0	M	WAKE	0	0	0	SCCR1
\$102D	TIE	TCIE	RIE	ILIE	TE	RE	RWU	SBK	SCCR2
\$102E	TDRE	TC	RDRF	IDLE	OR	NF	FE	0	SCSR
\$102F	R7/T7	R6/T6	R5/T5	R4/T4	R3/T3	R2/T2	R1/T1	R0/T0	SCDR
\$1030	CCF	0	SCAN	MULT	CD	CC	CB	CA	ADCTL
\$1031	Bit 7	6	5	4	3	2	1	Bit 0	ADR1
\$1032	Bit 7	6	5	4	3	2	1	Bit 0	ADR2
\$1033	Bit 7	6	5	4	3	2	1	Bit 0	ADR3
\$1034	Bit 7	6	5	4	3	2	1	Bit 0	ADR4
\$1035	0	0	0	PTCON	BPRT3	BPRT2	BPRT1	BPRT0	BPROT
\$1036	PG7	PG6	PG5	PG4	PG3	PG2	PG1	PG0	PORTG
\$1037	DDG7	DDG6	DDG5	DDG4	DDG3	DDG2	DDG1	DDG0	DDRG
\$1038									Reserved
\$1039	ADPU	CSEL	IRQE	DLY	CME	0	CR1	CR0	OPTION
\$103A	Bit 7	6	5	4	3	2	1	Bit 0	COPRST
\$103B	ODD	EVEN	ELAT	BYTE	ROW	ERASE	EELAT	PGM	PPROG
\$103C	RBOOT	SMOD	MDA	IRVNE	PSEL3	PSEL2	PSEL1	PSEL0	HPRIO
\$103D	RAM3	RAM2	RAM1	RAM0	REG3	REG2	REG1	REG0	INIT
\$103E	TILOP	0	OCCR	CBYP	DISR	FCM	FCOP	TCON	TEST1
\$103F	0	0	0	0	NOSEC	NOCOP	EPON	EEON	CONFIG

Hardware priority is built into RAM and I/O remapping. Registers have priority over both RAM and EPROM, and RAM has priority over EPROM. When the 64-byte register block is mapped at the same location as the RAM and EPROM, a read of the dual-mapped location results in a read of the register. If RAM is relocated on EPROM, RAM has priority.

The 512 bytes of fully static RAM store instructions, variables, and temporary data. The direct addressing mode can access RAM locations using a one-byte address operand, saving program memory space and execution time, depending on the application. RAM contents are preserved during periods of processor inactivity by two methods, both of which reduce power consumption.

In the software-based STOP mode, the clocks are stopped while V_{DD} powers the MCU. Because power supply current is directly related to operating frequency in CMOS integrated circuits, only a very small amount of leakage exists when the clocks are stopped. Refer to **SECTION 5 RESETS AND INTERRUPTS** for more information about STOP and WAIT.

In the second method, the MODB/ V_{STBY} pin can supply RAM power from a battery backup or from a second power supply, as shown in Figure 4–3. Using the MODB/ V_{STBY} pin may require external hardware, but can be justified when a significant amount of external circuitry is operating from V_{DD} . If V_{STBY} is used to maintain RAM contents, reset must be held low whenever V_{DD} is below normal operating level. Refer to **SECTION 5 RESETS AND INTERRUPTS**.

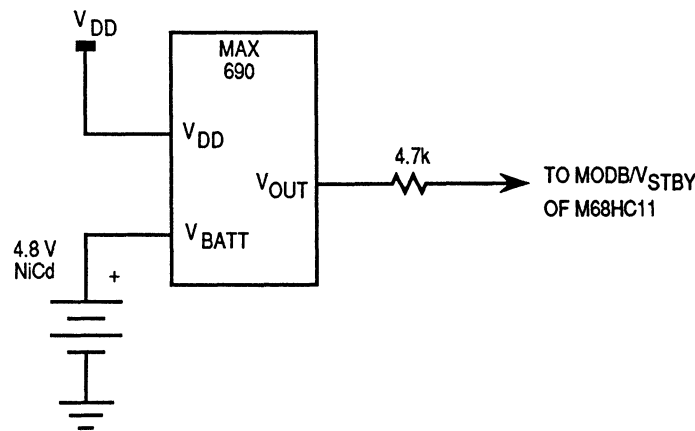

Figure 4–3. RAM Standby MODB/ V_{STBY} Connections

The bootloader program is contained in the 256-byte bootstrap ROM. This ROM, which appears as internal memory space at locations \$BF00–\$BFFF, is enabled only if the MCU is reset in special bootstrap mode.

The 16 Kbytes of EPROM is enabled out of reset and located at \$C000–\$FFFF in all modes if the EPON bit in the CONFIG register is one. EPROM is enabled out of reset in single-chip and bootstrap modes, regardless of the state of EPON.

The 512 bytes of EEPROM are located at \$B600–\$B7FF and have the same read cycle time as the internal ROM. EEPROM can be programmed or erased by software and an on-chip charge pump allows EEPROM changes using the single 5 Vdc supply.

4.2.1 Priority and Mode Select Register

The four operating modes are selected with the logic states of the mode A (MODA) and mode B (MODB) pins during reset. The MODA and MODB logic levels determine the logic state of the special mode (SMOD) and mode A (MDA) control bits in the HPRI0 register.

After reset is released, the mode select pins no longer influence the MCU operating mode. For single-chip mode, the MODA pin is connected to a logic zero. For expanded mode, MODA is normally connected to V_{DD} through a pull-up resistor of 4.7 k Ω . The MODA pin also functions as the load instruction register (\overline{LIR}) pin when the MCU is not in reset. The open drain active low \overline{LIR} output pin drives low during the first E cycle of each instruction. The MODB pin also functions as standby power input, V_{STBY} , which maintains RAM contents in the absence of V_{DD} . Refer to Table 4–2 for information about hardware mode selection.

HPRI0 — Highest Priority I-Bit Interrupt and Miscellaneous **\$103C**

Bit 7	6	5	4	3	2	1	Bit 0
RBOOT	SMOD	MDA	IRVNE	PSEL3	PSEL2	PSEL1	PSEL0
RESET: —	—	—	—	0	1	0	1

The values of the RBOOT, SMOD, IRVNE, and MDA at reset depend on the mode during initialization. Refer to Tables 4–2 and 4–3.

Table 4–2. Hardware Mode Select Summary

Inputs		Mode	Control Bits in HPRI0 (Latched at Reset)		
MODB	MODA		RBOOT	SMOD	MDA
1	0	Single-Chip	0	0	0
1	1	Expanded Multiplexed	0	0	1
0	0	Special Bootstrap	1	1	0
0	1	Special Test	0	1	1

Table 4–3. IRVNE Status

Mode	IRVNE Out of Reset	E Clock Out of Reset	IRV Out of Reset	IRVNE Affects Only
Single-Chip	0	On	Off	E
Expanded	0	On	Off	IRV
Boot	0	On	Off	E
Special Test	1	On	On	IRV

RBOOT — Read Bootstrap ROM

Has meaning only when the SMOD bit is a one (special bootstrap mode or special test mode). At all other times this bit is clear and cannot be written.

0 = Bootloader ROM disabled and not in map

1 = Bootloader ROM enabled and located in map at \$BF00–\$BFFF

SMOD — Special Mode Select

This bit reflects the inverse of the MODB input pin at the rising edge of reset. It is set if the MODB input pin is low during reset. If MODB is high during reset, it is cleared. SMOD can be cleared under software control from the special modes, thus changing the operating mode of the MCU. SMOD can never be set by software.

0 = Normal mode variation in effect

1 = Special mode variation in effect

MDA — Mode Select A

The mode select A bit reflects the status of the MODA input pin at the rising edge of reset. While the SMOD bit is set (special bootstrap or special test mode in effect), the MDA bit can be written, thus changing the operating mode of the MCU. When the SMOD bit is clear, the MODA bit is read-only and the operating mode cannot be changed without going through a reset sequence.

0 = Normal single-chip or special bootstrap mode in effect

1 = Normal expanded or special test mode in effect

IRVNE — Internal Read Visibility/Not E

The IRVNE control bit allows internal read accesses to be available on the external data bus during factory testing or emulation. If this capability is used for other purposes, bus conflicts can occur because the bidirectional data bus is driven out during a read of internal addresses, even though the R/W line suggests a high impedance read mode.

0 = No internal read visibility on external bus

1 = Internal read data driven out data bus

IRVNE also determines whether the E clock is driven out or forced low.

0 = E functions as clock output

1 = E pin driven low

PSEL[3:0] — Priority Select Bits

Refer to **SECTION 5 RESETS AND INTERRUPTS**.

4.2.2 System Initialization

Registers and bits that control initialization and the basic configuration of the MCU are protected against writes except under special circumstances. The protection mechanism, overridden in special operating modes, permits writing these bits only within the first 64 bus cycles after any reset, and then only once after each reset. If the MCU is going to be changed to a normal mode after being reset in a special mode, write to the protected registers before writing the SMOD control bit to zero.

4.2.2.1 CONFIG Register

The CONFIG register consists of an EEPROM byte and static latches that control the startup configuration of the MCU. The contents of the EEPROM byte are transferred into static working latches during reset sequences. The operation of the MCU is controlled directly by these latches and not by CONFIG itself. In normal modes, changes to CONFIG do not affect operation of the MCU until after the next reset sequence. When programming, the CONFIG register itself is accessed. When the CONFIG register is read, the static latches are accessed.

CONFIG — System Configuration

\$103F

Bit 7	6	5	4	3	2	1	Bit 0
0	0	0	0	NOSEC	NOCOP	EPON	EEON

RESET: 0 0 0 0 1 — — —

Bits [7:4] — Not implemented
Always read zero

NOSEC — EPROM Security Disable

NOSEC is invalid unless the security mask option is specified before the MCU is manufactured.

- 0 = Security enabled
- 1 = Security disabled

NOCOP — COP System Disable

Refer to **SECTION 5 RESETS AND INTERRUPTS**.

EPON — PROM Enable

When this bit is clear, the 16 Kbyte EPROM is disabled and that memory space becomes externally addressed. In single-chip and bootstrap modes, EPON is forced to one to enable EPROM regardless of how the EEPROM-based CONFIG register is programmed.

- 0 = EPROM removed from the memory map
- 1 = EPROM present in the memory map

EEON — EEPROM Enable

When this bit is clear, the EEPROM is disabled and that memory space becomes externally addressed.

0 = EEPROM removed from the memory map

1 = EEPROM present in the memory map

4.2.2.2 INIT Register

The internal registers used to control the operation of the MCU can be relocated on 4K boundaries within the memory space with the use of INIT. This 8-bit special-purpose register can change the default locations of the RAM and control registers within the MCU memory map. It can be written to only once within the first 64 E-clock cycles after a reset, and then it becomes a read-only register.

INIT — RAM and I/O Mapping Register

\$103D

	Bit 7	6	5	4	3	2	1	Bit 0
	RAM3	RAM2	RAM1	RAM0	REG3	REG2	REG1	REG0
RESET:	0	0	0	0	0	0	0	1

RAM[3:0] — RAM Map Position

These four bits, which specify the upper hexadecimal digit of the RAM address, control position of RAM in the memory map. RAM can be positioned at the beginning of any 4K page in the memory map. It is initialized to address \$0000 out of reset. Refer to Table 4-4.

REG[3:0] — 64-Byte Register Block Position

These four bits specify the upper hexadecimal digit of the address for the 64-byte block of internal registers. The register block, positioned at the beginning of any 4K page (\$x000) in the memory map, is initialized to address \$1000 out of reset. Refer to Table 4-5.

Table 4-4. RAM Mapping

RAM[3:0]	Address
0000	\$0000-\$01FF
0001	\$1000-\$11FF
0010	\$2000-\$21FF
0011	\$3000-\$31FF
0100	\$4000-\$41FF
0101	\$5000-\$51FF
0110	\$6000-\$61FF
0111	\$7000-\$71FF
1000	\$8000-\$81FF
1001	\$9000-\$91FF
1010	\$A000-\$A1FF
1011	\$B000-\$B1FF
1100	\$C000-\$C1FF
1101	\$D000-\$D1FF
1110	\$E000-\$E1FF
1111	\$F000-\$F1FF

Table 4-5. Register Mapping

REG[3:0]	Address
0000	\$0000-\$003F
0001	\$1000-\$103F
0010	\$2000-\$203F
0011	\$3000-\$303F
0100	\$4000-\$403F
0101	\$5000-\$503F
0110	\$6000-\$603F
0111	\$7000-\$703F
1000	\$8000-\$803F
1001	\$9000-\$903F
1010	\$A000-\$A03F
1011	\$B000-\$B03F
1100	\$C000-\$C03F
1101	\$D000-\$D03F
1110	\$E000-\$E03F
1111	\$F000-\$F03F

4.2.2.3 OPTION Register

The 8-bit special-purpose OPTION register sets internal system configuration options during initialization. The time protected control bits, IRQE, DLY, and CR[1:0] can be written to only once after a reset and then they become read-only. This minimizes the possibility of any accidental changes to the system configuration.

OPTION — System Configuration Options

\$1039

Bit 7	6	5	4	3	2	1	Bit 0
ADPU	CSEL	IRQE*	DLY*	CME	0	CR1*	CR0*

RESET: 0 0 0 1 0 0 0 0

*Can be written only once in first 64 cycles out of reset in normal modes, or at any time in special modes.

ADPU — Analog-to-Digital Converter Power-Up

Refer to **SECTION 10 ANALOG-TO-DIGITAL CONVERTER**.

CSEL — Clock Select

Selects alternate clock source for on-chip EEPROM charge pump. CSEL also selects the clock source for the A/D converter, a function discussed in **SECTION 10 ANALOG-TO-DIGITAL CONVERTER**.

IRQE — Configure $\overline{\text{IRQ}}$ for Edge-Sensitive Only Operation

0 = $\overline{\text{IRQ}}$ is configured for level-sensitive operation

1 = $\overline{\text{IRQ}}$ is configured for edge-sensitive only operation

DLY — Enable Oscillator Startup Delay

0 = The oscillator startup delay coming out of STOP is bypassed and the MCU resumes processing within about four bus cycles.

1 = A delay of approximately 4000 E-clock cycles is imposed as the MCU is started up from the STOP power-saving mode. This delay allows the crystal oscillator to stabilize.

CME — Clock Monitor Enable

Refer to **SECTION 5 RESETS AND INTERRUPTS**.

Bit 2 — Not implemented

Always reads zero

CR[1:0] — COP Timer Rate Select Bits

The internal E clock is first divided by 2^{15} before it enters the COP watchdog system. These control bits determine a scaling factor for the watchdog timer. Refer to **SECTION 5 RESETS AND INTERRUPTS**.

4.2.2.4 BPROT Register

This register prevents inadvertent writes to both the CONFIG register and EEPROM. The active bits in this register are initialized to one out of reset and can only be cleared during the first 64 E-clock cycles after reset in the normal modes. When these bits are cleared, the associated EEPROM section and the CONFIG register can be programmed or erased. EEPROM is only visible if the EEON bit in the CONFIG register is one. The bits in the BPROT register can be written back to one at any time to protect EEPROM and the CONFIG register. In test or bootstrap modes, write protection is inhibited and BPROT can be written repeatedly.

BPROT — Block Protect

\$1035

	Bit 7	6	5	4	3	2	1	Bit 0
	0	0	0	PTCON	BPRT3	BPRT2	BPRT1	BPRT0
RESET:	0	0	0	1	1	1	1	1

Bits [7:5] — Not implemented

Always read zero

PTCON — Protect CONFIG Register

0 = CONFIG register can be programmed or erased normally

1 = CONFIG register cannot be programmed or erased

BPRT[3:0] — Block Protect Bits for EEPROM

When set, these bits protect a block of EEPROM from being programmed or erased. Refer to Table 4–6. When cleared, they allow programming and erasing of the associated block.

Table 4–6. EEPROM Block Protect

Bit Name	Block Protected	Block Size
BPRT0	\$B600–\$B61F	32 Bytes
BPRT1	\$B620–\$B65F	64 Bytes
BPRT2	\$B660–\$B6DF	128 Bytes
BPRT3	\$B6E0–\$B7FF	288 Bytes

4.2.3 EPROM, EEPROM and CONFIG Programming

Refer to the following guidelines when erasing or programming EPROM, EEPROM, and the CONFIG register.

4.2.3.1 EPROM Programming

Using the on-chip EPROM programming feature requires an external 12.25-volt power supply (V_{PP}). Normal programming is accomplished using the PPROG register. Program EPROM at room temperature only and place an opaque label over the quartz window after programming.

There are three methods of programming and verifying EPROM. In the first method, the PROM emulation (PROG) mode, program the EPROM as an industry standard EPROM by adapting the MCU footprint to that of the 27256-type EPROM, as shown in Figure 4–4, and use an appropriate EPROM programmer.

If the MCU is operating with V_{PP} voltage on the $\overline{XIRQ/V_{PP}}$ pin, the $\overline{IRQ/CE}$ pin must be pulled to a high level before the address and data are changed to program the next location.

In the third method, use the following procedure to program the EPROM through the MCU with the EPON bit set in the CONFIG register. On entry, A = data to be programmed and X = EPROM address

EPROG	LDAB	#\$20	
	STAB	\$103B	Set ELAT bit (PGM=0) to enable EPROM latches.
	STAA	\$0, X	Store data to EPROM address
	LDAB	#\$21	
	STAB	\$103B	Set PGM bit (ELAT=1) to enable EPROM programming voltage
	JSR	DLYEP	Delay 2–4 ms
	CLR	\$103B	Turn off programming voltage and set to READ mode

In the second method, the EPROM is programmed by software while in the special test or bootstrap modes. User-developed software can be uploaded through the SCI, or a ROM resident EPROM programming utility can be used. To use the resident utility, bootload a three-byte program consisting of a single jump instruction to \$BF00. \$BF00 is the starting address of a resident EPROM programming utility. The utility program sets the X and Y index registers to default values, then receives programming data from an external host and puts it in EPROM. The value in IX determines programming delay time. The value in IY is a pointer to the first address in EPROM to be programmed (default = \$D000). When the utility program is ready to receive programming data, it sends the host the \$FF character. Then it waits. When the host sees the \$FF character, the EPROM programming data is sent, starting with location \$D000. After the last byte to be programmed is sent and the corresponding verification data is returned, the programming operation is terminated by resetting the MCU.

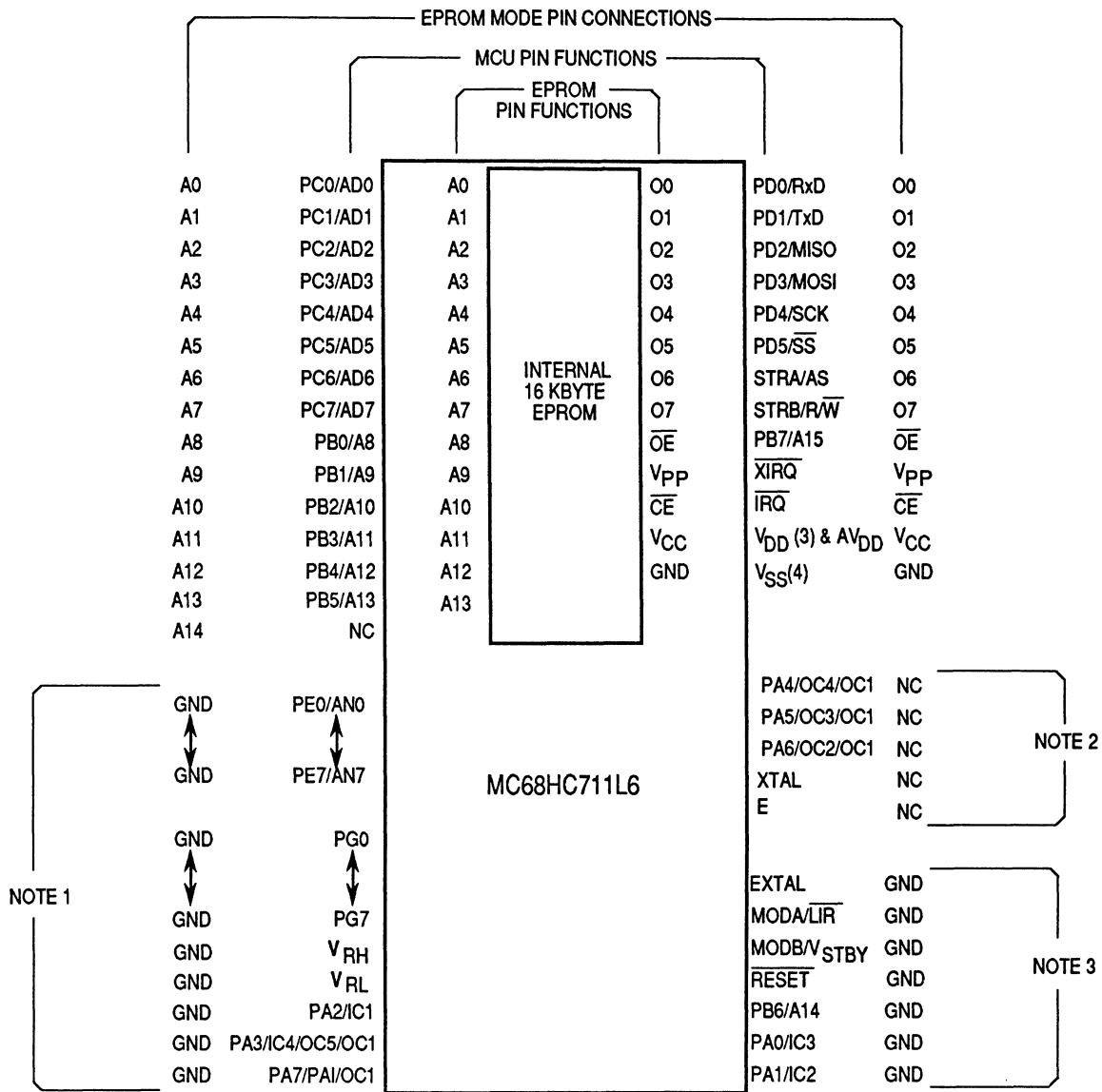

- NOTES: 1. Unused inputs — grounding is recommended.
 2. Unused outputs — these pins should be left unterminated.
 3. These pins must be grounded for PROG mode.

Figure 4–4. MC68HC711L6 PROG Mode Connections

4.2.3.2 EEPROM Programming

The erased state of an EEPROM bit is one. During a read operation, bit lines are precharged to one. The floating gate devices of programmed bits conduct and pull the bit lines to zero. Unprogrammed bits remain at the precharged level and are read as ones. Programming a bit to one causes no change. Programming a bit to zero changes the bit so that subsequent reads return zero.

When appropriate bits in the BPROT register are cleared, the 8-bit PPROG register controls programming and erasing the EEPROM. The PPROG register can be read or written at any time, but logic enforces defined programming and erasing sequences to prevent unintentional changes to EEPROM data. When the EELAT bit in the PPROG register is cleared, the EEPROM can be read as if it were a ROM.

The V_{PP} power supply voltage to the EEPROM array is not enabled until there has been a write to PPROG with ELAT set and PGM cleared. This must be followed by a write to a valid EEPROM location or to the CONFIG address, and then a write to PPROG with both the EELAT and PGM bits set. Any attempt to set both EELAT and PGM during the same write operation results in neither bit being set.

PPROG — EEPROM Programming Control

\$103B

	Bit 7	6	5	4	3	2	1	Bit 0
	ODD	EVEN	ELAT	BYTE	ROW	ERASE	EELAT	PGM
RESET:	0	0	0	0	0	0	0	0

ODD — Program Odd Rows in Half of EEPROM (Test)

EVEN — Program Even Rows in Half of EEPROM (Test)

ELAT — EPROM (OTEPROM) Latch Control

0 = EPROM address and data bus configured for normal reads and cannot be programmed

1 = EPROM address and data bus configured for programming and cannot be read

BYTE — Byte/Erase Select

This bit overrides the ROW bit. Refer to Table 4–7.

0 = Row or bulk erase

1 = Erase only one byte

ROW — Row/All Erase Select

If BYTE is 1, ROW has no meaning. Refer to Table 4–7.

0 = Bulk erase

1 = Row erase

Table 4–7. EEPROM Erase

BYTE	ROW	Action
0	0	Bulk Erase (All 512 Bytes)
0	1	Row Erase (16 Bytes)
1	0	Byte Erase
1	1	Byte Erase

ERASE — Erase Mode Select

- 0 = Normal read or program mode
- 1 = Erase mode

EELAT — EEPROM Latch Control

- 0 = EEPROM address and data bus configured for normal reads and cannot be programmed
- 1 = EEPROM address and data bus configured for programming or erasing and cannot be read

PGM — EEPROM and EPROM (OTPROM) Program Command

- 0 = Programming voltage to EEPROM and EPROM array switched off
- 1 = Programming voltage to EEPROM or EPROM array switched on

During EEPROM programming, the ROW and BYTE bits of PPROG are not used. If the frequency of the E clock is 1 MHz or less, set the CSEL bit in the OPTION register. Recall that zeros must be erased by a separate erase operation before programming. The following examples of how to program an EEPROM byte assume that the appropriate bits in BPROT are cleared.

PROG	LDAB	#\$02	EELAT=1
	STAB	\$103B	Set EELAT bit
	STAA	\$B600	Store data to EEPROM address
	LDAB	#\$03	EELAT=EEPGM=1
	STAB	\$103B	Turn on programming voltage
	JSR	DLY10	Delay 10 ms
	CLR	\$103B	Turn off high voltage and set to READ mode

4.2.3.3 EEPROM Bulk Erase

The following is an example of how to bulk erase the 512-byte EEPROM. The CONFIG register is not affected in this example.

BULKE	LDAB	#\$02	EELAT=1
	STAB	\$103B	Set EELAT bit
	STAA	\$B600	Store data to any EEPROM address
	LDAB	#\$03	EELAT=EEPGM=1
	STAB	\$103B	Turn on programming voltage
	JSR	DLY10	Delay 10 ms
	CLR	\$103B	Turn off high voltage and set to READ mode

4.2.3.4 EEPROM Row Erase

The following example shows how to perform a fast erase of large sections of EEPROM.

ROWE	LDAB	#\$0E	ROW=ERASE=EELAT=1
	STAB	\$103B	Set to ROW erase mode
	STAB	0,X	Write any data to any address in ROW
	LDAB	#\$0F	ROW=ERASE=EELAT=EEPGM=1
	STAB	\$103B	Turn on high voltage
	JSR	DLY10	Delay 10 ms
	CLR	\$103B	Turn off high voltage and set to READ mode

4.2.3.5 EEPROM Byte Erase

The following is an example of how to erase a single byte of EEPROM.

BYTEE	LDAB	#\$16	BYTE=ERASE=EELAT=1
	STAB	\$103B	Set to BYTE erase mode
	STAB	0,X	Write any data to address to be erased
	LDAB	#\$17	BYTE=ERASE=EELAT=EEPGM=1
	STAB	\$103B	Turn on high voltage
	JSR	DLY10	Delay 10 ms
	CLR	\$103B	Turn off high voltage and set to READ mode

4.2.3.6 CONFIG Register Programming

Because the CONFIG register is implemented with EEPROM cells, use EEPROM procedures to erase and program this register. The procedure for programming is the same as for programming a byte in the EEPROM array, except that the CONFIG register address is used. CONFIG can be programmed or erased (including byte erase) while the MCU is operating in any mode, provided that PTCON in BPROT is clear. To change the value in the CONFIG register, complete the following procedure. Do not initiate a reset until the procedure is complete.

1. Erase the CONFIG register.
2. Program the new value to the CONFIG address.
3. Initiate reset.

4.2.3.7 EEPROM Security

The optional security feature, NOSEC, protects the EEPROM and RAM contents from unauthorized access. A program, or a key portion of a program, can be protected against unauthorized duplication. To accomplish this, the protection mechanism restricts operation of protected devices to the single-chip modes, and thus prevents the memory locations from being monitored externally because single-chip modes do not allow visibility of the internal address and data buses. Resident programs, however, have unlimited access to the internal EEPROM and RAM and can read, write, or transfer the contents of these memories. Contact a Motorola representative for the availability of this function.

SECTION 5 RESETS AND INTERRUPTS

Resets and interrupt operations load the program counter with a vector that points to a new location from which instructions are to be fetched. A reset immediately stops execution of the current instruction and forces the program counter to a known starting address. Internal registers and control bits are initialized so the MCU can resume executing instructions. An interrupt temporarily suspends normal program execution while an interrupt service routine is being executed. After an interrupt has been serviced, the main program resumes as if there had been no interruption.

5.1 Resets

There are four possible sources of reset. Power-on reset (POR) and external reset share the normal reset vector. The computer operating properly (COP) system and the clock monitor each has its own vector.

5.1.1 Power-On Reset

A positive transition on V_{DD} generates a power-on reset (POR), which is used only for power-up conditions. POR cannot be used to detect drops in power supply voltages. A 4064 t_{CYC} (internal clock cycle) delay after the oscillator becomes active allows the clock generator to stabilize. If \overline{RESET} is at logical zero at the end of 4064 t_{CYC} , the CPU remains in the reset condition until \overline{RESET} goes to logical one.

It is important to protect the MCU during power transitions. Most M68HC11 systems need an external circuit that holds the \overline{RESET} pin low whenever V_{DD} is below the minimum operating level. This external voltage level detector, or other external reset circuits, are the usual source of reset in a system. The POR circuit only initializes internal circuitry during cold starts. Refer to Figure 2-2.

5.1.2 External Reset

The CPU distinguishes between internal and external reset conditions by sensing whether the reset pin rises to a logic one in less than two E-clock cycles after an internal device releases reset. When a reset condition is sensed, the \overline{RESET} pin is driven low by an internal device for four E-clock cycles, then released. Two E-clock cycles later it is sampled. If the pin is still held low, the

CPU assumes that an external reset has occurred. If the pin is high, it indicates that the reset was initiated internally by either the COP system or the clock monitor. It is not advisable to connect an external resistor capacitor (RC) power-up delay circuit to the reset pin of M68HC11 devices because the circuit charge time constant can cause the device to misinterpret the type of reset that occurred.

5.1.3 COP Reset

The MCU includes a COP system to help protect against software failures. When the COP is enabled, the software is responsible for keeping a free-running watchdog timer from timing out. When the software is no longer being executed in the intended sequence, a system reset is initiated.

The state of the NOCOP bit in the CONFIG register determines whether the COP system is enabled or disabled. To change the enable status of the COP system, change the contents of the CONFIG register and then perform a system reset. In the special test and bootstrap operating modes, the COP system is initially inhibited by the disable resets (DISR) control bit in the TEST1 register. The DISR bit can subsequently be written to zero to enable COP resets.

The COP timer rate control bits CR[1:0] in the OPTION register determine the COP timeout period. The system E clock is divided by 2^{15} and then further scaled by a factor shown in Table 5–1. After reset, these bits are zero, which selects the fastest timeout period. In normal operating modes, these bits can only be written once within 64 bus cycles after reset.

Table 5–1. COP Timeout

CR[1:0]	Divide E/ 2^{15} By	XTAL = 4.0 MHz Timeout –0/+32.8 ms	XTAL = 8.0 MHz Timeout –0/+16.4 ms	XTAL = 12.0 MHz Timeout –0/+10.9 ms
00	1	32.768 ms	16.384 ms	10.923 ms
01	4	131.072 ms	65.536 ms	43.691 ms
10	16	524.288 ms	262.140 ms	174.76 ms
11	64	2.097 sec	1.049 sec	699.05 ms
	E =	1.0 MHz	2.0 MHz	3.0 MHz

	Bit 7	6	5	4	3	2	1	Bit 0
	7	6	5	4	3	2	1	0
RESET:	0	0	0	0	0	0	0	0

Complete the following reset sequence to service the COP timer. Write \$55 to COPRST to arm the COP timer clearing mechanism. Then write \$AA to COPRST to clear the COP timer. Performing instructions between these two steps is possible as long as both steps are completed in the correct sequence before the timer times out.

5.1.4 Clock Monitor Reset

The clock monitor circuit is based on an internal RC time delay. If no MCU clock edges are detected within this RC time delay, the clock monitor can optionally generate a system reset. The clock monitor function is enabled or disabled by the CME control bit in the OPTION register. The presence of a timeout is determined by the RC delay, which allows the clock monitor to operate without any MCU clocks.

Clock monitor is used as a backup for the COP system. Because the COP needs a clock to function, it is disabled when the clocks stop. Therefore, the clock monitor system can detect clock failures not detected by the COP system.

Semiconductor wafer processing causes variations of the RC timeout values between individual devices. An E-clock frequency below 10 kHz is detected as a clock monitor error. An E-clock frequency of 200 kHz or more prevents clock monitor errors. Using the clock monitor function when the E-clock is below 200 kHz is not recommended.

Special considerations are needed when a STOP instruction is executed and the clock monitor is enabled. Because the STOP function causes the clocks to be halted, the clock monitor function generates a reset sequence if it is enabled at the time the STOP mode was initiated. Before executing a STOP instruction, clear the CME bit in the OPTION register to zero to disable the clock monitor. After recovery from STOP, set the CME bit to logic one to enable the clock monitor.

5.1.5 OPTION Register

OPTION — System Configuration Options

\$1039

	Bit 7	6	5	4	3	2	1	Bit 0
	ADPU	CSEL	IRQE	DLY	CME	0	CR1	CR0
RESET:	0	0	0	1	0	0	0	0

ADPU — Analog-to-Digital Converter Power-Up

Refer to **SECTION 10 ANALOG-TO-DIGITAL CONVERTER**.

CSEL — Clock Select

Refer to **SECTION 10 ANALOG-TO-DIGITAL CONVERTER**.

IRQE — Configure $\overline{\text{IRQ}}$ for Edge-Sensitive Only Operation

DLY — Enable Oscillator Startup Delay

CME — Clock Monitor Enable

This control bit can be read or written at any time and controls whether or not the internal clock monitor circuit triggers a reset sequence when the system clock is slow or absent. When it is clear, the clock monitor circuit is disabled. When it is set, the clock monitor circuit is enabled. Reset clears the CME bit.

CR[1:0] — COP Timer Rate Select Bits

These control bits determine a scaling factor for the watchdog timer.

5.1.6 CONFIG Register

CONFIG — Configuration Control Register

\$103F

	Bit 7	6	5	4	3	2	1	Bit 0
	0	0	0	0	NOSEC	NOCOP	EPON	EEON
RESET:	0	0	0	0	1	—	—	—

Bits [7:4] — Not implemented

Always read zero

NOSEC — EEPROM Security Disable

Refer to **SECTION 4 OPERATING MODES AND ON-CHIP MEMORY**.

NOCOP — COP System Disable

0 = COP enabled (forces reset on timeout)

1 = COP disabled (does not force reset on timeout)

EPON — Enable On-Chip PROM

Refer to **SECTION 4 OPERATING MODES AND ON-CHIP MEMORY**.

EEON — Enable On-Chip EEPROM

Refer to **SECTION 4 OPERATING MODES AND ON-CHIP MEMORY**.

5.2 Effects of Reset

When a reset condition is recognized, the internal registers and control bits are forced to an initial state. Depending on the cause of the reset and the operating mode, the reset vector can be fetched from any of six possible locations. Refer to Table 5–2.

Table 5–2. Reset Cause, Reset Vector, and Operating Mode

Cause of Reset	Normal Mode Vector	Special Test or Bootstrap
POR or RESET Pin	\$FFFE, FFFF	\$BFFE, BFFF
Clock Monitor Failure	\$FFFC, FFFD	\$BFFC, \$BFFD
COP Watchdog Timeout	\$FFFA, FFFB	\$BFFA, BFFB

These initial states then control on-chip peripheral systems to force them to known startup states, as follows:

5.2.1 Central Processing Unit

After reset, the central processing unit (CPU) fetches the restart vector from the appropriate address during the first three cycles, and begins executing instructions. The stack pointer and other CPU registers are indeterminate immediately after reset; however, the X and I interrupt mask bits in the condition code register (CCR) are set to mask any interrupt requests. Also, the S bit in the CCR is set to inhibit the STOP mode.

5.2.2 Memory Map

After reset, the INIT register is initialized to \$01, putting the 512 bytes of RAM at locations \$0000 through \$01FF, and the control registers at locations \$1000 through \$103F.

5.2.3 Parallel I/O

When a reset occurs in expanded multiplexed operating modes, the pins used for parallel I/O are dedicated to the expansion bus. If a reset occurs during a single-chip operating mode, the STAF, STAI, and HNDS bits in the parallel input/output control register (PIOC) are cleared so that no interrupt is pending or enabled, and the simple strobed mode (rather than the full handshake mode) of parallel I/O is selected. The CWOM bit in PIOC is cleared so that port C is not in wired-OR mode. Port C is initialized as an input port (DDRC = \$00), port B is a general-purpose output port with all bits cleared. STRA is the edge-sensitive strobe A input and the active edge is initially configured to detect rising edges (EGA bit in the PIOC set), and STRB is the strobe B output and is initially a logic zero (the INVB bit in the PIOC is set). Port C, port D bits [0:5], port A bits [0:3]

and 7, and port E are configured as general-purpose high-impedance inputs. Port B and bits [4:6] of port A have their directions fixed as outputs and their reset state is a logic zero. Upon reset, port G becomes input only.

5.2.4 Timer

During reset, the timer system is initialized to a count of \$0000. The prescaler bits are cleared, and all output compare registers are initialized to \$FFFF. All input capture registers are indeterminate after reset. The output compare 1 mask (OC1M) register is cleared so that successful OC1 compares do not affect any I/O pins. The other four output compares are configured so that they do not affect any I/O pins on successful compares. All input capture edge-detector circuits are configured for capture disabled operation. The timer overflow interrupt flag and all eight timer function interrupt flags are cleared. All nine timer interrupts are disabled because their mask bits have been cleared.

The I4/O5 bit in the PACTL register is cleared to configure the I4/O5 function as OC5; however, the OM5:OL5 control bits in the TCTL1 register are clear so OC5 does not control the PA3 pin.

5.2.5 Real-Time Interrupt

The real-time interrupt flag (RTIF) is cleared and automatic hardware interrupts are masked. The rate control bits are cleared after reset and can be initialized by software before the real-time interrupt (RTI) system is used.

5.2.6 Pulse Accumulator

The pulse accumulator system is disabled at reset so that the PAI input pin defaults to being a general-purpose input pin.

5.2.7 Computer Operating Properly

The computer operating properly (COP) watchdog system is enabled if the NOCOP control bit in the CONFIG register is clear, and disabled if NOCOP is set. The COP rate is set for the shortest duration timeout.

5.2.8 Serial Communications Interface

The reset condition of the serial communications interface (SCI) system is independent of the operating mode. At reset, the SCI baud rate is indeterminate and must be established by a software write to the BAUD register. All transmit and receive interrupts are masked and both the transmitter and receiver are disabled so the port pins default to being general-purpose I/O lines. The SCI frame format is initialized to an 8-bit character size. The send break and receiver wake-up functions are disabled. The TDRE and TC status bits in

the SCI status register are both set, indicating that there is no transmit data in either the transmit data register or the transmit serial shift register. The RDRF, IDLE, OR, NF, and FE receive-related status bits are cleared.

5.2.9 Serial Peripheral Interface

The serial peripheral interface (SPI) system is disabled by reset. The port pins associated with this function default to being general-purpose I/O lines.

5.2.10 Analog-to-Digital Converter

The A/D converter configuration is indeterminate after reset. The ADPU bit is cleared by reset, which disables the A/D converter system. The conversion complete flag is cleared by reset.

5.2.11 System

The EEPROM programming controls are disabled, so the memory system is configured for normal read operation. PSEL[3:0] are initialized with the value \$0101, causing the external $\overline{\text{IRQ}}$ pin to have the highest I-bit interrupt priority. The $\overline{\text{IRQ}}$ pin is configured for level sensitive operation (for wired-OR systems). The RBOOT, SMOD, and MDA bits in the HPRIO register reflect the status of the MODB and MODA inputs at the rising edge of reset. The DLY control bit is set to specify that an oscillator start-up delay is imposed upon recovery from STOP mode. The clock monitor system is disabled by CME equals zero.

5.3 Reset and Interrupt Priority

Resets and interrupts have a hardware priority that determines which reset or interrupt is serviced first when simultaneous requests occur. Any maskable interrupt can be given priority over other maskable interrupts.

The first six interrupt sources are not maskable. The priority arrangement for these sources is as follows:

1. POR or $\overline{\text{RESET}}$ pin
2. Clock monitor reset
3. COP watchdog reset
4. $\overline{\text{XIRQ}}$ interrupt
5. Illegal opcode interrupt
6. Software interrupt (SWI)

The maskable interrupt sources have the following priority arrangement:

1. $\overline{\text{IRQ}}$
2. Real-time interrupt
3. Timer input capture 1
4. Timer input capture 2
5. Timer input capture 3
6. Timer output compare 1
7. Timer output compare 2
8. Timer output compare 3
9. Timer output compare 4
10. Timer input capture 4/output compare 5
11. Timer overflow
12. Pulse accumulator overflow
13. Pulse accumulator input edge
14. SPI transfer complete
15. SCI system

Any one of these interrupts can be assigned the highest maskable interrupt priority by writing the appropriate value to the PSEL bits in the HPRIO register. Otherwise, the priority arrangement remains the same. An interrupt that is assigned highest priority is still subject to global masking by the I bit in the CCR, or by any associated local bits. Interrupt vectors are not affected by priority assignment. To avoid race conditions, HPRIO can only be written while I-bit interrupts are inhibited.

5.3.1 Highest Priority Interrupt and Miscellaneous Register

HPRIO — Highest Priority I-Bit Interrupt and Miscellaneous

\$103C

	Bit 7	6	5	4	3	2	1	Bit 0
	RBOOT	SMOD	MDA	IRVNE	PSEL3	PSEL2	PSEL1	PSEL0
RESET:	—	—	—	—	0	1	0	1

The values of the RBOOT, SMOD, IRVNE, and MDA reset bits depend on the mode during initialization. Refer to Table 4–2.

RBOOT — Read Bootstrap ROM

Has meaning only when the SMOD bit is a one (special bootstrap mode or special test mode). At all other times this bit is clear and cannot be written. Refer to **SECTION 4 OPERATING MODES AND ON-CHIP MEMORY** for more information.

SMOD — Special Mode Select

This bit reflects the inverse of the MODB input pin at the rising edge of reset. Refer to **SECTION 4 OPERATING MODES AND ON-CHIP MEMORY** for more information.

MDA — Mode Select A

The mode select A bit reflects the status of the MODA input pin at the rising edge of reset. Refer to **SECTION 4 OPERATING MODES AND ON-CHIP MEMORY** for more information.

IRVNE — Internal Read Visibility, Not E

The IRVNE control bit allows internal read accesses to be available on the external data bus during factory testing or emulation. Refer to **SECTION 4 OPERATING MODES AND ON-CHIP MEMORY** for more information.

PSEL[3:0] — Priority Select Bits

These bits select one interrupt source to be elevated above all other I-bit-related sources and can be written to only while the I bit in the CCR is set (interrupts disabled).

Table 5–3. Highest Priority Interrupt Selection

PSEL[3:0]	Interrupt Source Promoted
0 0 0 0	Timer Overflow
0 0 0 1	Pulse Accumulator Overflow
0 0 1 0	Pulse Accumulator Input Edge
0 0 1 1	SPI Serial Transfer Complete
0 1 0 0	SCI Serial System
0 1 0 1	Reserved (Default to $\overline{\text{IRQ}}$)
0 1 1 0	$\overline{\text{IRQ}}$ (External Pin or Parallel I/O)
0 1 1 1	Real-Time Interrupt
1 0 0 0	Timer Input Capture 1
1 0 0 1	Timer Input Capture 2
1 0 1 0	Timer Input Capture 3
1 0 1 1	Timer Output Compare 1
1 1 0 0	Timer Output Compare 2
1 1 0 1	Timer Output Compare 3
1 1 1 0	Timer Output Compare 4
1 1 1 1	Timer Input Capture 4/Output Compare 5

5.4 Interrupts

The MCU has 18 interrupt vectors that support 23 interrupt sources. The 15 maskable interrupts are generated by on-chip peripheral systems. These interrupts are recognized when the global interrupt mask bit (I) in the condition code register (CCR) is clear. The three nonmaskable interrupt sources are illegal opcode trap, software interrupt, and $\overline{\text{XIRQ}}$ pin. Refer to Table 5–4, which shows the interrupt sources and vector assignments for each source.

Table 5–4. Interrupt and Reset Vector Assignments

Vector Address	Interrupt Source	CC Register Mask	Local Mask
FFC0, C1 — FFD4, D5	Reserved	—	—
FFD6, D7	SCI Serial System	I Bit	
	• SCI Transmit Complete		TCIE
	• SCI Transmit Data Register Empty		TIE
	• SCI Idle Line Detect		ILIE
	• SCI Receiver Overrun		RIE
	• SCI Receive Data Register Full		RIE
FFD8, D9	SPI Serial Transfer Complete	I Bit	SPIE
FFDA, DB	Pulse Accumulator Input Edge	I Bit	PAII
FFDC, DD	Pulse Accumulator Overflow	I Bit	PAOVI
FFDE, DF	Timer Overflow	I Bit	TOI
FFE0, E1	Timer Input Capture 4/Output Compare 5	I Bit	I4/O5I
FFE3, E2	Timer Output Compare 4	I Bit	OC4I
FFE4, E5	Timer Output Compare 3	I Bit	OC3I
FFE6, E7	Timer Output Compare 2	I Bit	OC2I
FFE8, E9	Timer Output Compare 1	I Bit	OC1I
FFEA, EB	Timer Input Capture 3	I Bit	IC3
FFEC, ED	Timer Input Capture 2	I Bit	IC2I
FFEE, EF	Timer Input Capture 1	I Bit	IC1I
FFF0, F1	Real-Time Interrupt	I Bit	RTII
FFF2, F3	Parallel I/O Handshake	I Bit	STAI
	$\overline{\text{IRQ}}$ (External Pin)		None
FFF4, F5	$\overline{\text{XIRQ}}$ Pin	X Bit	None
FFF6, F7	Software Interrupt	None	None
FFF8, F9	Illegal Opcode Trap	None	None
FFFA, FB	COP Failure	None	NOCOP
FFFC, FD	COP Clock Monitor Fail	None	CME
FFFE, FF	$\overline{\text{RESET}}$	None	None

SMOD — Special Mode Select

This bit reflects the inverse of the MODB input pin at the rising edge of reset. Refer to **SECTION 4 OPERATING MODES AND ON-CHIP MEMORY** for more information.

MDA — Mode Select A

The mode select A bit reflects the status of the MODA input pin at the rising edge of reset. Refer to **SECTION 4 OPERATING MODES AND ON-CHIP MEMORY** for more information.

IRVNE — Internal Read Visibility, Not E

The IRVNE control bit allows internal read accesses to be available on the external data bus during factory testing or emulation. Refer to **SECTION 4 OPERATING MODES AND ON-CHIP MEMORY** for more information.

PSEL[3:0] — Priority Select Bits

These bits select one interrupt source to be elevated above all other I-bit-related sources and can be written to only while the I bit in the CCR is set (interrupts disabled).

Table 5–3. Highest Priority Interrupt Selection

PSEL[3:0]	Interrupt Source Promoted
0 0 0 0	Timer Overflow
0 0 0 1	Pulse Accumulator Overflow
0 0 1 0	Pulse Accumulator Input Edge
0 0 1 1	SPI Serial Transfer Complete
0 1 0 0	SCI Serial System
0 1 0 1	Reserved (Default to $\overline{\text{IRQ}}$)
0 1 1 0	$\overline{\text{IRQ}}$ (External Pin or Parallel I/O)
0 1 1 1	Real-Time Interrupt
1 0 0 0	Timer Input Capture 1
1 0 0 1	Timer Input Capture 2
1 0 1 0	Timer Input Capture 3
1 0 1 1	Timer Output Compare 1
1 1 0 0	Timer Output Compare 2
1 1 0 1	Timer Output Compare 3
1 1 1 0	Timer Output Compare 4
1 1 1 1	Timer Input Capture 4/Output Compare 5

5.4.1 Interrupt Recognition and Register Stacking

An interrupt can be recognized at any time after it is enabled by its local mask, if any, and by the global mask bit in the CCR. Once an interrupt source is recognized, the CPU responds at the completion of the instruction being executed. Interrupt latency varies according to the number of cycles required to complete the current instruction. When the CPU begins to service an interrupt, the contents of the CPU registers are pushed onto the stack in the order shown in Table 5–5. After the CCR value is stacked, the I bit and the X bit, if \overline{XIRQ} is pending, are set to inhibit further interrupts. The interrupt vector for the highest priority pending source is fetched, and execution continues at the address specified by the vector. At the end of the interrupt service routine, the return from interrupt instruction is executed and the saved registers are pulled from the stack in reverse order so that normal program execution can resume. Refer to **SECTION 3 CENTRAL PROCESSING UNIT** for further information.

Table 5–5. Stacking Order on Entry to Interrupts

Memory Location	CPU Registers
SP	PCL
SP – 1	PCH
SP – 2	IYL
SP – 3	IYH
SP – 4	IXL
SP – 5	IXH
SP – 6	ACCA
SP – 7	ACCB
SP – 8	CCR

5.4.2 Nonmaskable Interrupt Request

Nonmaskable interrupts are useful because they can always interrupt CPU operations. The most common use for such an interrupt is for serious system problems, such as program runaway or power failure. The \overline{XIRQ} input is an updated version of the nonmaskable NMI input of earlier MCUs.

Upon reset, both the X bit and I bits of the CCR are set to inhibit all maskable interrupts and \overline{XIRQ} . After minimum system initialization, software can clear the X bit by a TAP instruction, enabling \overline{XIRQ} interrupts. Thereafter, software cannot set the X bit. Thus, an \overline{XIRQ} interrupt is a nonmaskable interrupt. Because the operation of the I-bit-related interrupt structure has no effect on the X bit, the internal \overline{XIRQ} pin remains nonmasked. In the interrupt priority logic, the \overline{XIRQ} interrupt has a higher priority than any source that is maskable by the I bit. All I-bit-related interrupts operate normally with their own priority relationship.

When an I-bit-related interrupt occurs, the I bit is automatically set by hardware after stacking the CCR byte. The X bit is not affected. When an X-bit-related interrupt occurs, both the X and I bits are automatically set by hardware after stacking the CCR. A return from interrupt instruction restores the X and I bits to their pre-interrupt request state.

5.4.3 Illegal Opcode Trap

Because not all possible opcodes or opcode sequences are defined, the MCU includes an illegal opcode detection circuit, which generates an interrupt request. When an illegal opcode is detected and the interrupt is recognized, the current value of the program counter is stacked. After interrupt service is complete, reinitialize the stack pointer so repeated execution of illegal opcodes does not cause stack underflow. Left uninitialized, the illegal opcode vector can point to a memory location that contains an illegal opcode. This condition causes an infinite loop that causes stack underflow. The stack grows until the system crashes.

The illegal opcode trap mechanism works for all unimplemented opcodes on all four opcode map pages. The address stacked as the return address for the illegal opcode interrupt is the address of the first byte of the illegal opcode. Otherwise, it would be almost impossible to determine whether the illegal opcode had been one or two bytes. The stacked return address can be used as a pointer to the illegal opcode so the illegal opcode service routine can evaluate the offending opcode.

5.4.4 Software Interrupt

SWI is an instruction, and thus cannot be interrupted until complete. SWI is not inhibited by the global mask bits in the CCR. Because execution of SWI sets the I mask bit, once an SWI interrupt begins, other interrupts are inhibited until SWI is complete, or until user software clears the I bit in the CCR.

5.4.5 Maskable Interrupts

The maskable interrupt structure of the MCU can be extended to include additional external interrupt sources through the $\overline{\text{IRQ}}$ pin. The default configuration of this pin is a low-level sensitive wired-OR network. When an event triggers an interrupt, a software accessible interrupt flag is set. When enabled, this flag causes a constant request for interrupt service. After the flag is cleared, the service request is released.

5.4.6 Reset and Interrupt Processing

Figures 5–1 and 5–2 illustrate the reset and interrupt process. Figure 5–1 illustrates how the CPU begins from a reset and how interrupt detection relates to normal opcode fetches. Figure 5–2 is an expansion of a block in Figure 5–1 and illustrates interrupt priorities. Figure 5–3 shows the resolution of interrupt sources within the SCI subsystem.

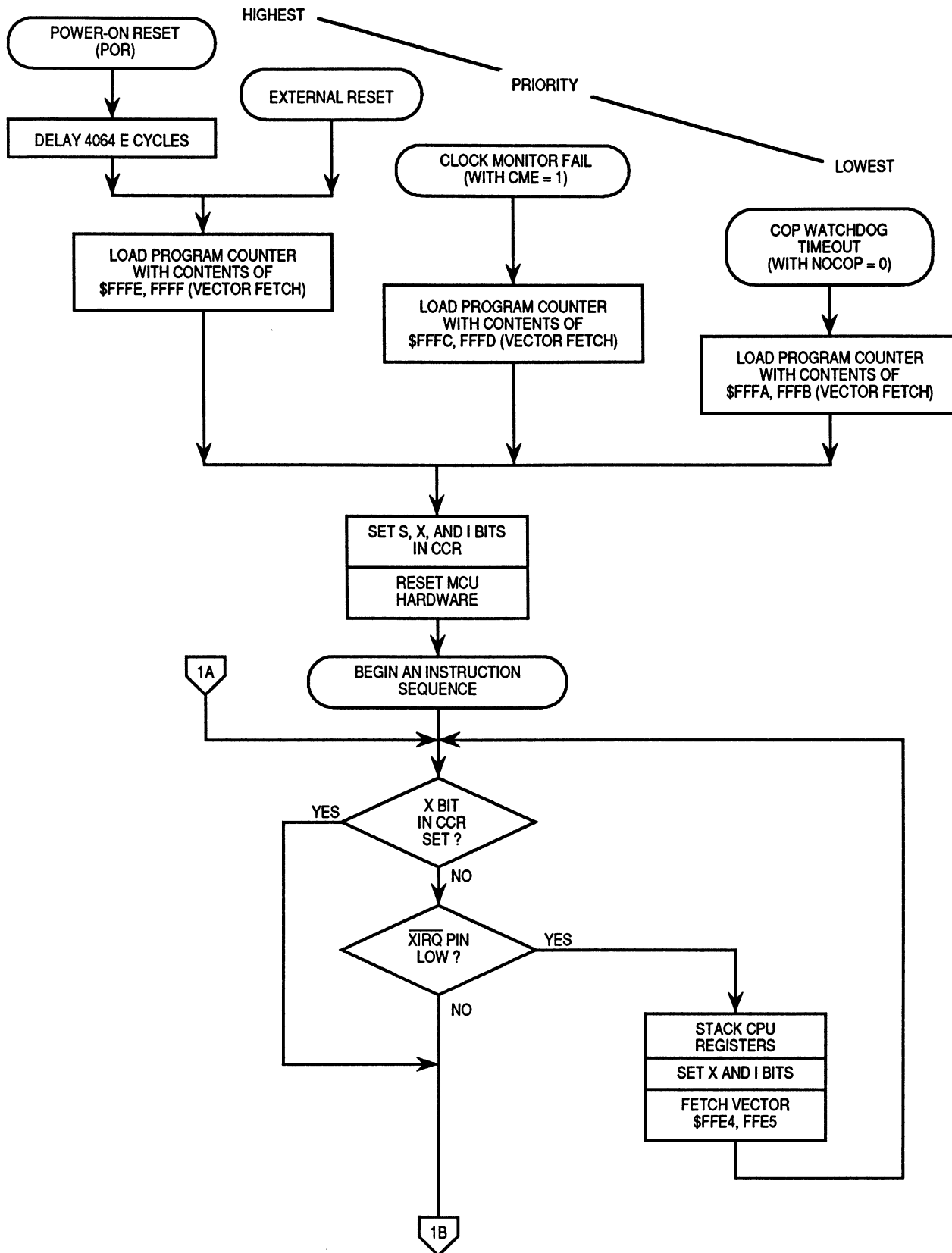

Figure 5-1. Processing Flow out of Reset (1 of 2)

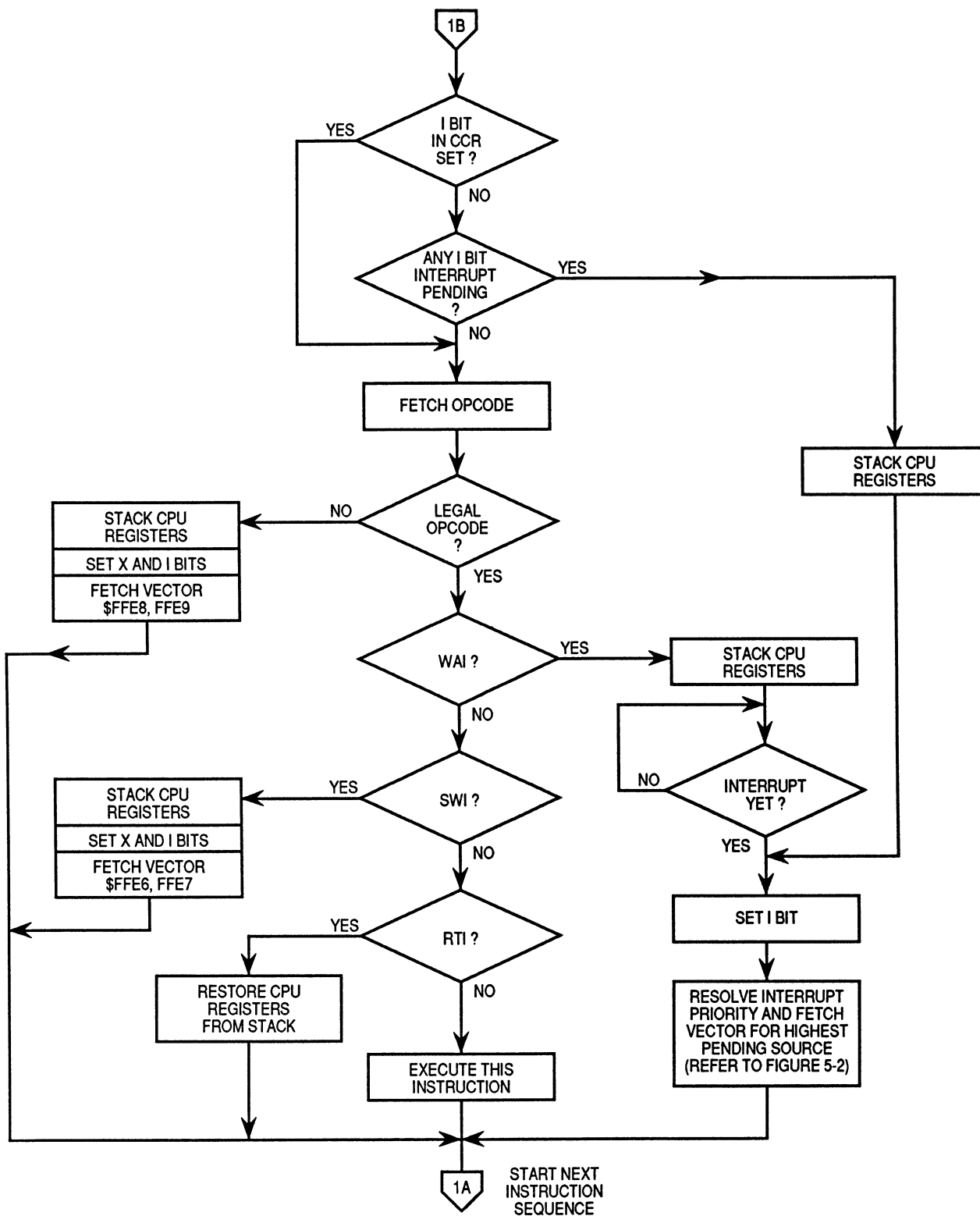

Figure 5-1. Processing Flow out of Reset (2 of 2)

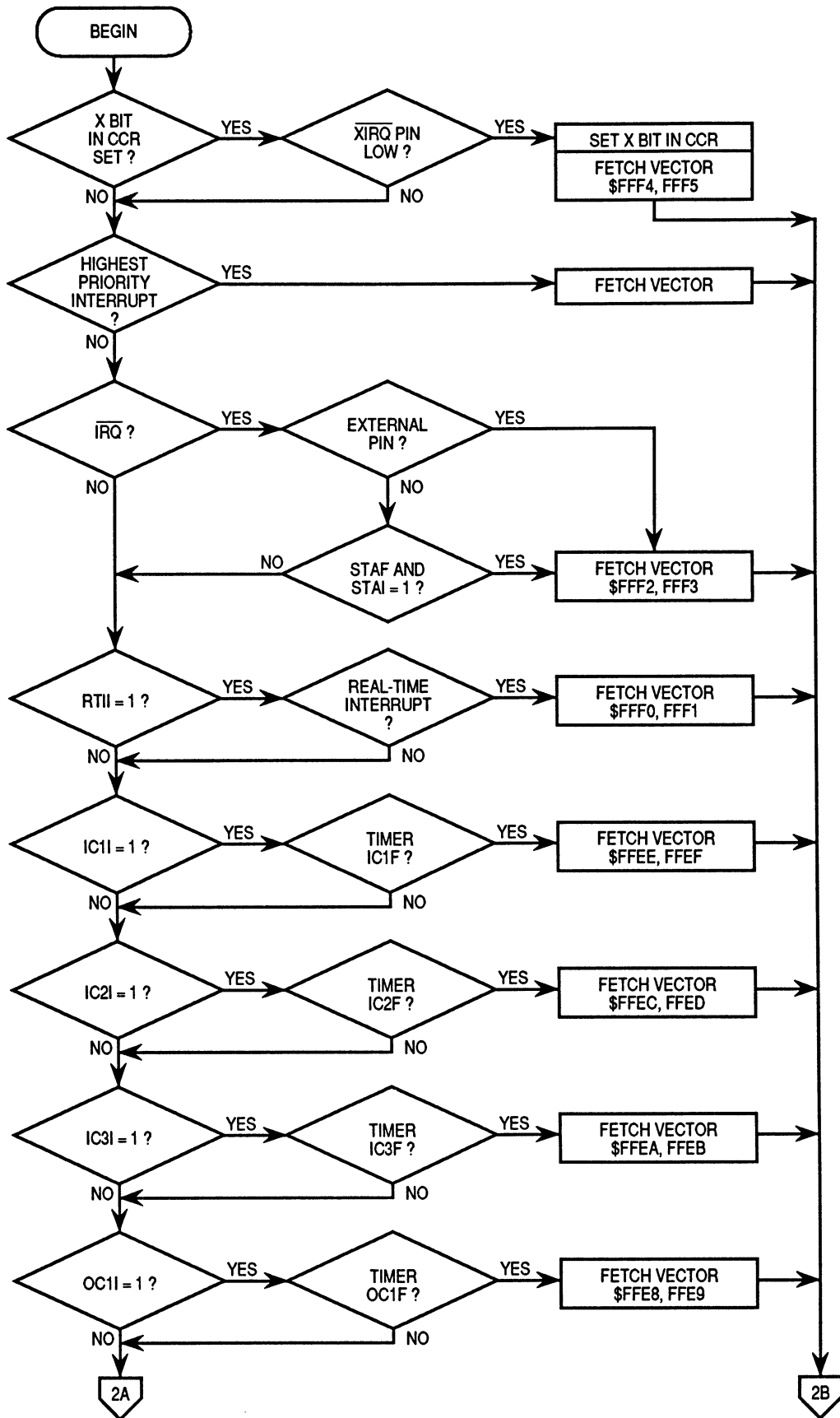

Figure 5-2. Interrupt Priority Resolution (1 of 2)

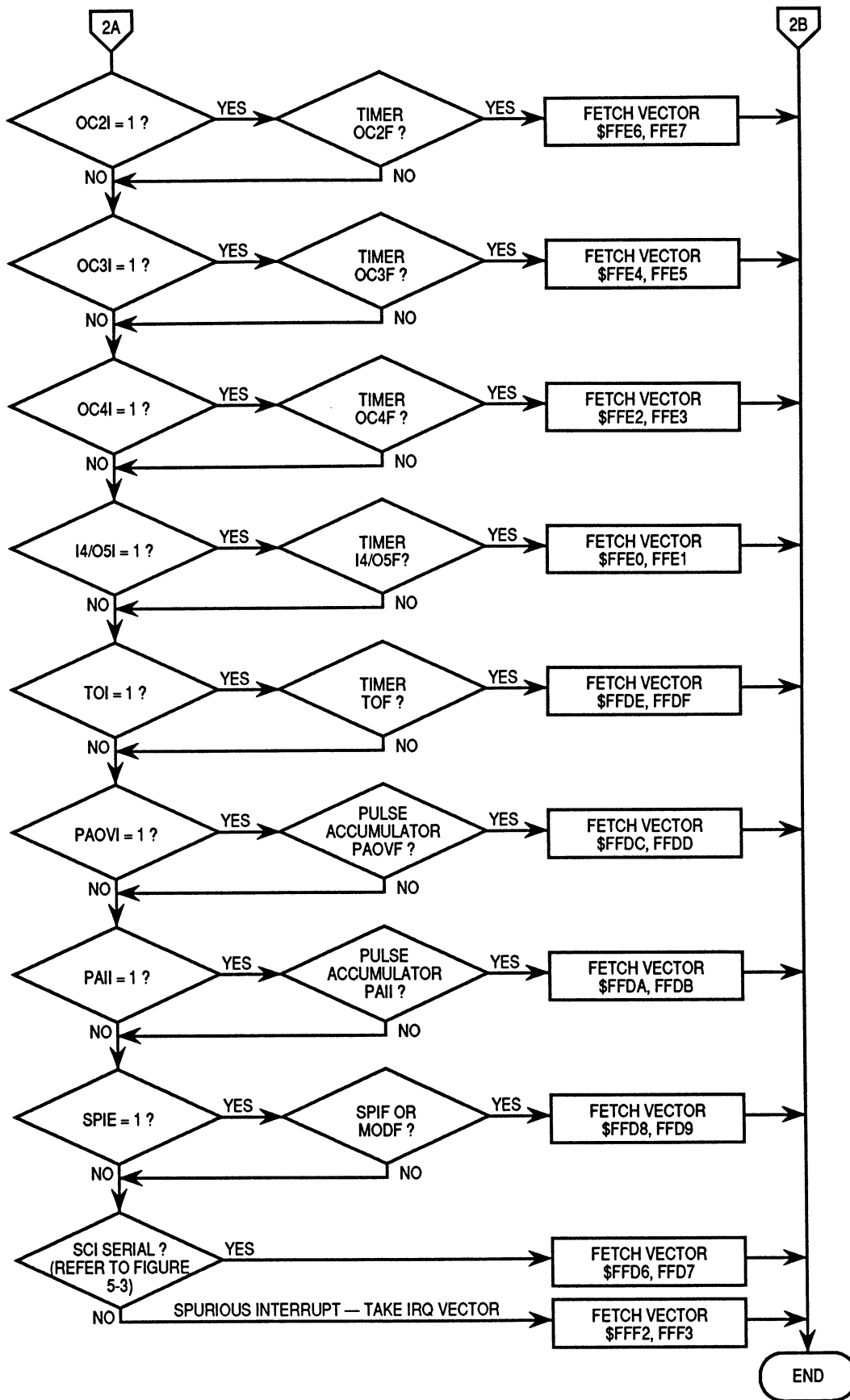

Figure 5-2. Interrupt Priority Resolution (2 of 2)

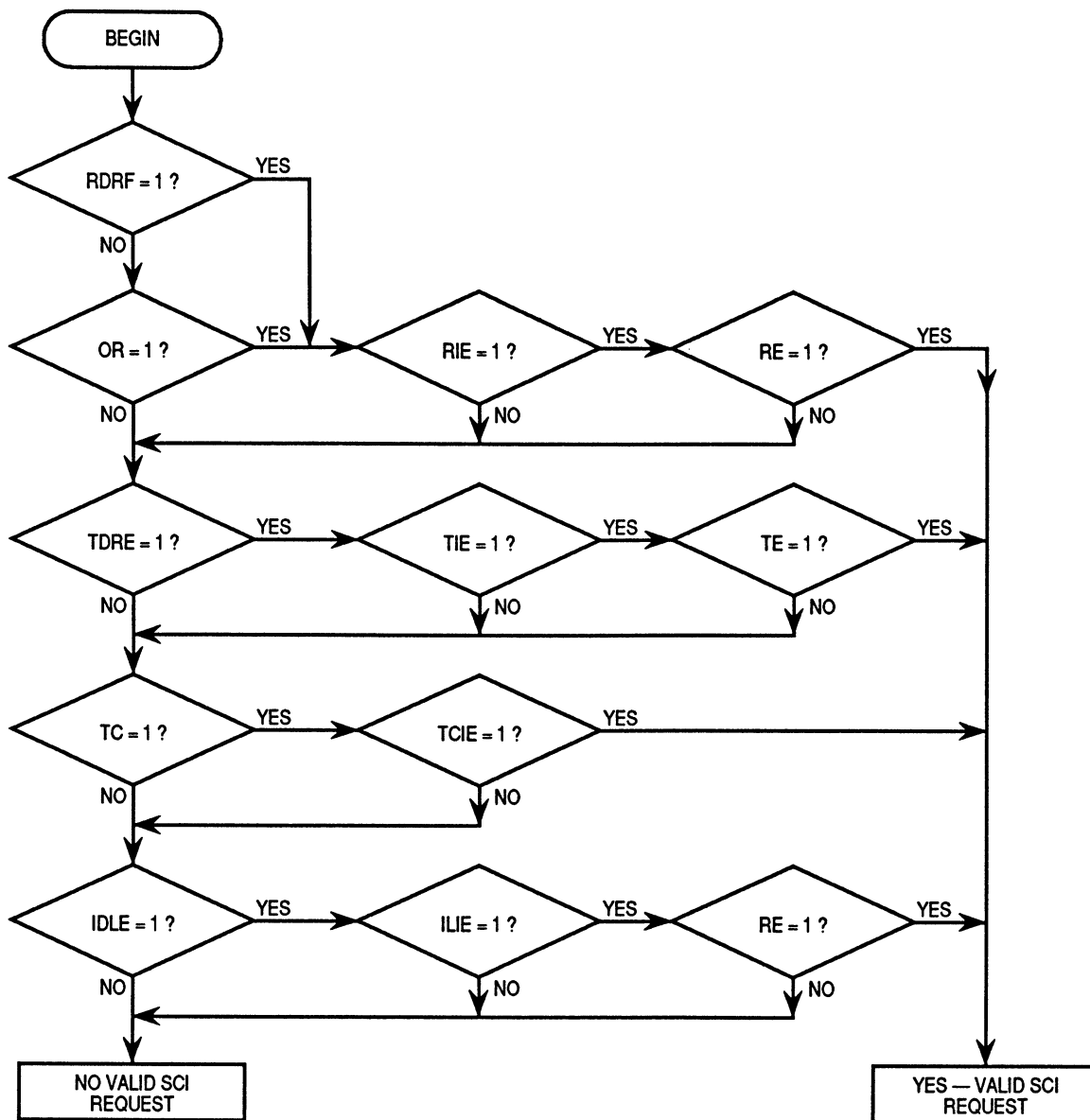

Figure 5-3. Interrupt Source Resolution Within SCI

5.5 Low Power Operation

Both STOP and WAIT suspend CPU operation until a reset or interrupt occurs. The WAIT condition suspends processing and reduces power consumption to an intermediate level. The STOP condition turns off all on-chip clocks and reduces power consumption to an absolute minimum while retaining the contents of all 512 bytes of RAM.

5.5.1 WAIT

The WAI opcode places the MCU in the WAIT condition, during which the CPU registers are stacked and CPU processing is suspended until a qualified interrupt is detected. The interrupt can be an external $\overline{\text{IRQ}}$, an $\overline{\text{XIRQ}}$, or any of the internally generated interrupts, such as the timer or serial interrupts. The on-chip crystal oscillator remains active throughout the WAIT standby period.

The reduction of power in the WAIT condition depends on how many internal clock signals driving on-chip peripheral functions can be shut down. The CPU is always shut down during WAIT. While in the wait state, the address/data bus repeatedly runs read cycles to the address where the CCR contents were stacked. The MPU leaves the wait state when it senses any interrupt that has not been masked.

The free-running timer system is shut down only if the I bit is set to one and the COP system is disabled by NOCOP being set to one. Several other systems can also be in a reduced power consumption state depending on the state of software-controlled configuration control bits. Power consumption by the analog-to-digital (A/D) converter is not affected significantly by the WAIT condition. However, the A/D converter current can be eliminated by writing the ADPU bit to zero. The SPI system is enabled or disabled by the SPE control bit. The SCI transmitter is enabled or disabled by the TE bit, and the SCI receiver is enabled or disabled by the RE bit. Therefore the power consumption in WAIT is dependent on the particular application.

5.5.2 STOP

Executing the STOP instruction while the S bit in the CCR is equal to zero places the MCU in the STOP condition. If the S bit is not zero, the STOP opcode is treated as a no-op (NOP). The STOP condition offers minimum power consumption because all clocks, including the crystal oscillator, are stopped while in this mode. To exit STOP and resume normal processing, a logic low level must be applied to one of the external interrupts ($\overline{\text{IRQ}}$ or $\overline{\text{XIRQ}}$) or to the $\overline{\text{RESET}}$ pin. A pending edge-triggered $\overline{\text{IRQ}}$ can also bring the CPU out of STOP.

Because all clocks are stopped in this mode, all internal peripheral functions also stop. The data in the internal RAM is retained as long as V_{DD} power is maintained. The CPU state and I/O pin levels are static and are unchanged by STOP. Therefore, when an interrupt comes to restart the system, the MCU resumes processing as if there were no interruption. If reset is used to restart the system a normal reset sequence results where all I/O pins and functions are also restored to their initial states.

To use the \overline{IRQ} pin as a means of recovering from STOP, the I bit in the CCR must be clear (\overline{IRQ} not masked). The \overline{XIRQ} pin can be used to wake up the MCU from STOP regardless of the state of the X bit in the CCR, although the recovery sequence depends on the state of the X bit. If X is set to zero (\overline{XIRQ} not masked), the MCU starts up, beginning with the stacking sequence leading to normal service of the \overline{XIRQ} request. If X is set to one (\overline{XIRQ} masked or inhibited), then processing continues with the instruction that immediately follows the STOP instruction, and no \overline{XIRQ} interrupt service is requested or pending.

Because the oscillator is stopped in STOP mode, a restart delay may be imposed to allow oscillator stabilization upon leaving STOP. If the internal oscillator is being used, this delay is required; however, if a stable external oscillator is being used, the DLY control bit can be used to bypass this startup delay. The DLY control bit is set by reset and can be optionally cleared during initialization. If the DLY equal to zero option is used to avoid startup delay on recovery from STOP, then reset should not be used as the means of recovering from STOP, as this causes DLY to be set again by reset, imposing the restart delay. This same delay also applies to power-on-reset, regardless of the state of the DLY control bit, but does not apply to a reset while the clocks are running.

SECTION 6 PARALLEL INPUT/OUTPUT

The MC68HC711L6 has six input/output (I/O) ports and up to 46 I/O lines, depending on the operating mode. Refer to Table 6–1, which is a summary of the ports and their shared functions.

Table 6–1. I/O Ports

Port	Input Pins	Output Pins	Bidirectional Pins	Shared Functions
Port A	3	3	2	Timer
Port B	—	8	—	High Order Address
Port C	—	—	8	Low Order Address and Data Bus
Port D	—	—	6	SCI and SPI
Port E	8	—	—	A/D Converter
Port G	—	—	8	None

6.1 Port A

Port A, which has three input only pins, three output only pins, and two bidirectional I/O pins, shares functions with the timer system.

PORTA — Port A Data

\$1000

	Bit 7	6	5	4	3	2	1	Bit 0
	PA7	PA6	PA5	PA4	PA3	PA2	PA1	PA0
RESET:	HIZ	0	0	0	HIZ	HIZ	HIZ	HIZ
Alt. Func:	PAI	OC2	OC3	OC4	IC4/OC5	IC1	IC2	IC3
And/or:	OC1	OC1	OC1	OC1	OC1	—	—	—

6.2 Port B

In the single-chip mode, all port B pins are general-purpose output pins. In the expanded multiplexed operating mode, all of the port B pins act as high-order [8:15] address output pins.

PORTB — Port B Data

\$1004

	Bit 7	6	5	4	3	2	1	Bit 0
	PB7	PB6	PB5	PB4	PB3	PB2	PB1	PB0
S. Chip or Boot:	PB7	PB6	PB5	PB4	PB3	PB2	PB1	PB0
RESET:	Reset forces port B pins low							
Expan. or Test:	A15	A14	A13	A12	A11	A10	A9	A8
RESET:	Reset configures pins as high order address outputs							

6.3 Port C

Port C pins are general-purpose bidirectional pins in single-chip mode, and multiplexed address and data pins in expanded mode. During reset, the port C output register is cleared in single-chip modes.

PORTC — Port C Data

\$1003

	Bit 7	6	5	4	3	2	1	Bit 0
	PC7	PC6	PC5	PC4	PC3	PC2	PC1	PC0
S. Chip or Boot:	PC7	PC6	PC5	PC4	PC3	PC2	PC1	PC0
RESET:	0	0	0	0	0	0	0	0
Expan. or Test:	A7/D7	A6/D6	A5/D5	A4/D4	A3/D3	A2/D2	A1/D1	A0/D0

NOTE

In single-chip and bootstrap modes, port C pins reset to high impedance inputs (DDRC bits are cleared to zero). In expanded and special test modes, port C pins are a multiplexed address/data bus and the port C register address is treated as an external memory location.

PORTCL — Port C Latched**\$1005**

	Bit 7	6	5	4	3	2	1	Bit 0
	PCL7	PCL6	PCL5	PCL4	PCL3	PCL2	PCL1	PCL0
RESET:	U	U	U	U	U	U	U	U

Writes affect port C pins. PORTCL is used in the handshake clearing mechanism. When an active edge occurs on the STRA pin, port C data is latched into the PORTCL register.

DDRC — Data Direction Register for Port C**\$1007**

	Bit 7	6	5	4	3	2	1	Bit 0
	DDC7	DDC6	DDC5	DDC4	DDC3	DDC2	DDC1	DDC0
RESET:	0	0	0	0	0	0	0	0

DDC7–DDC0 — Data Direction for Port C

0 = Input

1 = Output

6.4 Port D

In all modes, port D bits [0:5] can be used either for general-purpose I/O, or with the SCI and SPI subsystems. During reset, port D pins are configured as high impedance inputs (DDRD bits cleared to zero).

PORTD — Port D Data**\$1008**

	Bit 7	6	5	4	3	2	1	Bit 0
	0	0	PD5	PD4	PD3	PD2	PD1	PD0
RESET:	0	0	0	0	0	0	0	0
Alt. Func.:	—	—	\overline{SS}	SCK	MOSI	MISO	TxD	RxD

DDRD — Data Direction Register for Port D**\$1009**

	Bit 7	6	5	4	3	2	1	Bit 0
	0	0	DDD5	DDD4	DDD3	DDD2	DDD1	DDD0
RESET:	0	0	0	0	0	0	0	0
Alt. Func.:	—	—	PD5/ \overline{SS}	PD4/ SCK	PD3/ MOSI	PD2/ MISO	PD1/ TxD	PD0/ RxD

DDD5–DDD0 — Data Direction for Port D

When DDRD bit 5 is one and MSTR = 1 in SPCR, PD5/ \overline{SS} is a general-purpose output and mode fault logic is disabled.

- 0 = Input
- 1 = Output

PACTL — Pulse Accumulator Control

\$1026

	Bit 7	6	5	4	3	2	1	Bit 0
	DDRA7	PAEN	PAMOD	PEDGE	DDRA3	I4/O5	RTR1	RTR0
RESET:	0	0	0	0	0	0	0	0

DDRA7 — Data Direction for Port A Bit 7

Refer to **SECTION 9 TIMING SYSTEM**.

PAEN — Pulse Accumulator System Enable

Refer to **SECTION 9 TIMING SYSTEM**.

PAMOD — Pulse Accumulator Mode

Refer to **SECTION 9 TIMING SYSTEM**.

PEDGE — Pulse Accumulator Edge Control

Refer to **SECTION 9 TIMING SYSTEM**.

DDRA3 — Data Direction for Port A Bit 3

Overridden if an output compare function is configured to control the PA3 pin

- 0 = Input
- 1 = Output

I4/O5 — Input Capture 4/Output Compare 5

Refer to **SECTION 9 TIMING SYSTEM**.

RTR[1:0] — RTI Interrupt Rate Select

Refer to **SECTION 9 TIMING SYSTEM**.

6.5 Port E

Port E is used for general-purpose static inputs or pins that share functions with the A/D converter system. When some port E pins are being used for general-purpose input and others are being used as A/D inputs, PORTE should not be read during the sample portion of an A/D conversion.

PORTE — Port E Data

\$100A

	Bit 7	6	5	4	3	2	1	Bit 0
	PE7	PE6	PE5	PE4	PE3	PE2	PE1	PE0
RESET:	U	U	U	U	U	U	U	U
Alt. Func.:	AN7	AN6	AN5	AN4	AN3	AN2	AN1	AN0

6.6 Port G

Port G is used for general-purpose I/O. Each port bit can be selected as output or input by writing the corresponding bit in the data direction register to a logic one for output and logic zero for input.

PORTG — Port G Data

\$1036

	Bit 7	6	5	4	3	2	1	Bit 0
	PG7	PG6	PG5	PG4	PG3	PG2	PG1	PG0
RESET:	0	0	0	0	0	0	0	0

DDRG — Data Direction Register for Port C

\$1037

	Bit 7	6	5	4	3	2	1	Bit 0
	DDC7	DDC6	DDC5	DDC4	DDC3	DDC2	DDC1	DDC0
RESET:	0	0	0	0	0	0	0	0

DDC7–DDC0 — Data Direction for Port C

0 = Input

1 = Output

6.7 Handshake Protocol

Simple and full handshake input and output functions are available on ports B and C pins in single-chip mode. In simple strobed mode, port B is a strobed output port and port C is a latching input port. The two activities are available simultaneously.

The STRB output is pulsed for two E-clock periods each time there is a write to the PORTB register. The INVB bit in the PIOC register controls the polarity of STRB pulses. Port C levels are latched into the alternate port C latch (PORTCL) register on each assertion of the STRA input. STRA edge select, flag, and interrupt enable bits are located in the PIOC register. Any or all of the port C lines can still be used as general-purpose I/O while in strobed input mode.

Full handshake modes use port C pins and the STRA and STRB lines. Input and output handshake modes are supported, and output handshake mode has a three-stated variation. STRA is an edge detecting input and STRB is a handshake output. Control and enable bits are located in the PIOC register.

In full input handshake mode, the MCU asserts STRB to signal an external system that it is ready to latch data. Port C logic levels are latched into PORTCL when the STRA line is asserted by the external system. The MCU then deasserts STRB. The MCU reasserts STRB after the PORTCL register is read. In this mode, a mix of latched inputs, static inputs, and static outputs is allowed on port C, differentiated by the data direction bits and use of the PORTC and PORTCL registers.

In full output handshake mode, the MCU writes data to PORTCL which, in turn, asserts the STRB output to indicate that data is ready. The external system reads port C data and asserts the STRA input to acknowledge that data has been received.

In the three-state variation of output handshake mode, lines intended as three-state handshake outputs are configured as inputs by clearing the corresponding DDRC bits. The MCU writes data to PORTCL and asserts STRB. The external system responds by activating the STRA input, which forces the MCU to drive the data in PORTC out on all of the port C lines. After the trailing edge of the active signal on STRA, the MCU deasserts the STRB signal. The three-state mode variation does not allow part of port C to be used for static inputs while other port C pins are being used for handshake outputs. Refer to the PIOC register description for further information.

6.8 Parallel I/O Control Register

The parallel handshake functions are available only in the single-chip operating mode. The parallel I/O control register (PIOC) is a read/write register except for bit 7, which is read only. Table 6–2 shows a summary of handshake operations.

PIOC — Parallel I/O Control

\$1002

	Bit 7	6	5	4	3	2	1	Bit 0
	STAF	STAI	CWOM	HNDS	OIN	PLS	EGA	INVB
RESET:	0	0	0	0	0	U	1	1

STAF — Strobe A Interrupt Status Flag

0 = No edge on strobe A

1 = Selected edge on strobe A

STAF is set when the selected edge occurs on Strobe A. This bit can be cleared by a read of PIOC with STAF set followed by a read of PORTCL (simple strobed or full input handshake mode) or a write to PORTCL (output handshake mode).

STAI — Strobe A Interrupt Enable Mask

0 = STAF does not request interrupt

1 = STAF requests interrupt

CWOM — Port C Wired-OR Mode (affects all eight port C pins)

0 = Port C outputs are normal CMOS outputs

1 = Port C outputs are open-drain outputs

HNDS — Handshake Mode

0 = Simple strobe mode

1 = Full input or output handshake mode

OIN — Output or Input Handshake Select

HNDS must be set to one for this bit to have meaning.

0 = Input handshake

1 = Output handshake

PLS — Pulse/Interlocked Handshake Operation

HNDS must be set to one for this bit to have meaning. When interlocked handshake is selected, strobe B is active until the selected edge of strobe A is detected.

0 = Interlocked handshake

1 = Pulsed handshake (Strobe B pulses high for two E-clock cycles.)

EGA — Active Edge for Strobe A

0 = STRA falling edge selected, high level activates port C outputs (output handshake)

1 = STRA rising edge selected, low level activates port C outputs (output handshake)

INVB — Invert Strobe B

0 = Active level is logic zero

1 = Active level is logic one

Table 6–2. Parallel I/O Control

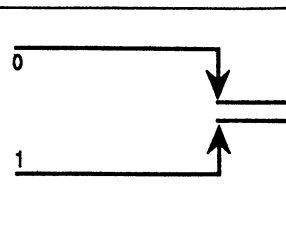
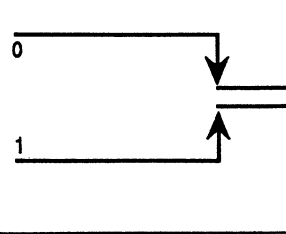
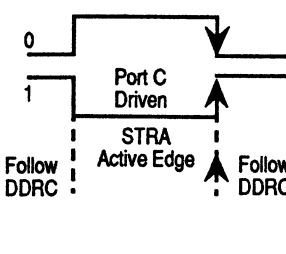
	STAF Clearing Sequence	HNDS	OIN	PLS	EGA	Port C	Port B
Simple strobed mode	Read PIOC with STAF = 1 then read PORTCL	0	X	X		Inputs latched into PORTCL on any active edge on STRA	STRB pulses on writes to port B
Full input handshake	Read PIOC with STAF = 1 then read PORTCL	1	0	0 = STRB active level 1 = STRB active pulse		Inputs latched into PORTCL on any active edge on STRA	Normal output port, unaffected in handshake modes
Full output handshake	Read PIOC with STAF = 1 then write to PORTCL	1	1	0 = STRB active level 1 = STRB active pulse		Driven as outputs if STRA at active level, follows DDRC if STRA not at active level	Normal output port, unaffected in handshake modes

SECTION 7 SERIAL COMMUNICATIONS INTERFACE

The serial communications interface (SCI) is a universal asynchronous receiver transmitter (UART), one of two independent serial I/O subsystems in the MC68HC711L6. It has a standard nonreturn to zero (NRZ) format (one start, eight or nine data, and one stop bit). Several baud rates are available. The SCI transmitter and receiver are independent, but use the same data format and bit rate.

7.1 Data Format

The serial data format requires the following conditions:

1. An idle line in the high state before transmission or reception of a message
2. A start bit, logic zero, transmitted or received, that indicates the start of each character
3. Data that is transmitted and received least significant bit (LSB) first
4. A stop bit, logic one, used to indicate the end of a frame (A frame consists of a start bit, a character of eight or nine data bits, and a stop bit.)
5. A break (defined as the transmission or reception of a logic zero for some multiple number of frames)

Selection of the word length is controlled by the M bit of SCI control register SCCR1.

7.2 Transmit Operation

The SCI transmitter includes a parallel transmit data register (SCDR) and a serial shift register. The contents of the serial shift register can only be written through the SCDR. This double buffered operation allows a character to be shifted out serially while another character is waiting in the SCDR to be transferred into the serial shift register. The output of the serial shift register is applied to TxD as long as transmission is in progress or the transmit enable (TE) bit of serial communication control register 2 (SCCR2) is set. The block diagram, Figure 7-1, shows the transmit serial shift register, and the buffer logic at the top of the figure.

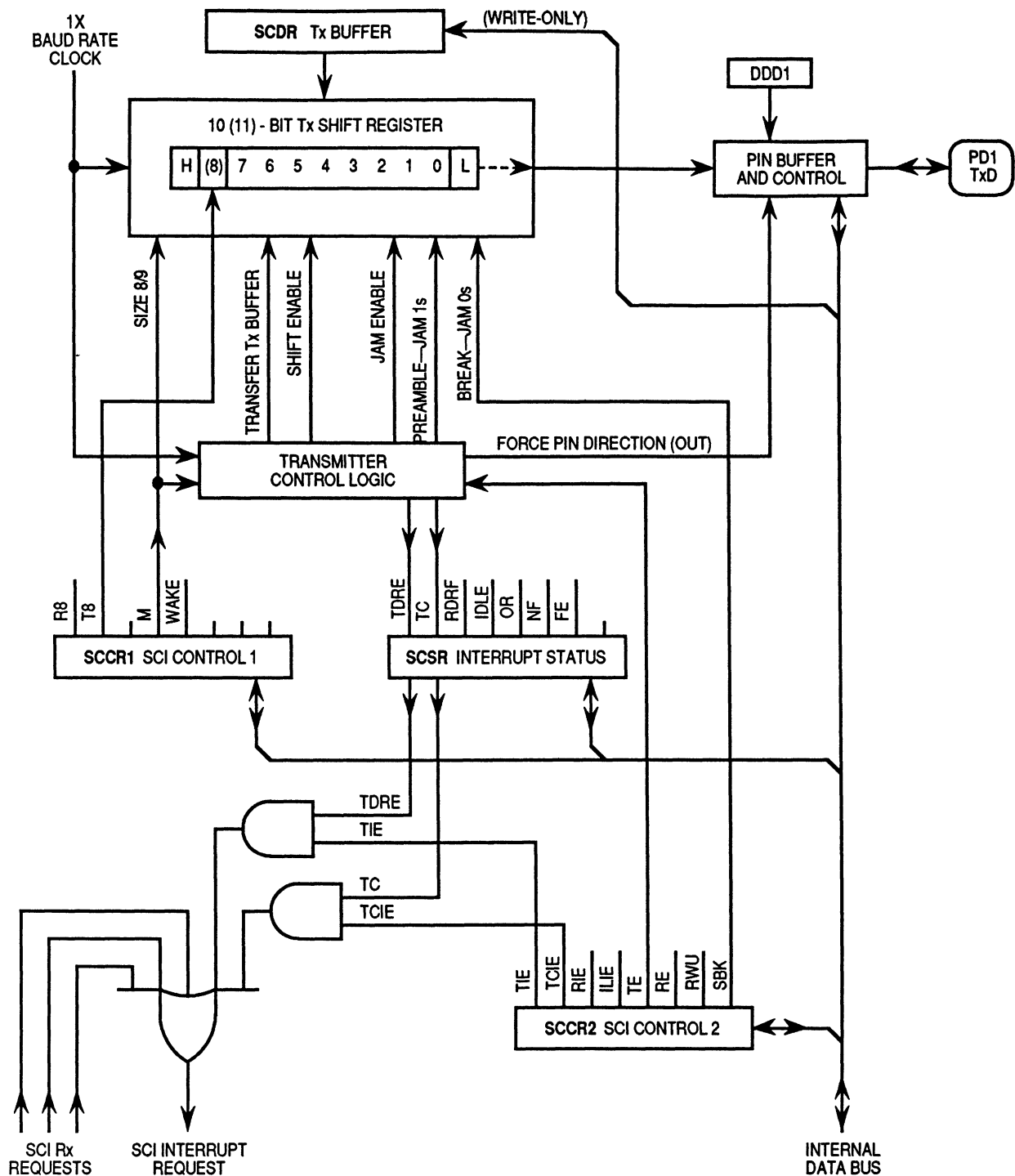

Figure 7-1. SCI Transmitter Block Diagram

7.3 Receive Operation

During receive operations, the transmit sequence is reversed. The serial shift register receives data and transfers it to a parallel receive data register (SCDR) as a complete word. This double-buffered operation allows a character to be

shifted in serially while another character is already in the SCDR. An advanced data recovery scheme distinguishes valid data from noise in the serial data stream. The data input is selectively sampled to detect receive data, and a majority voting circuit determines the value and integrity of each bit. Refer to Figure 7-2.

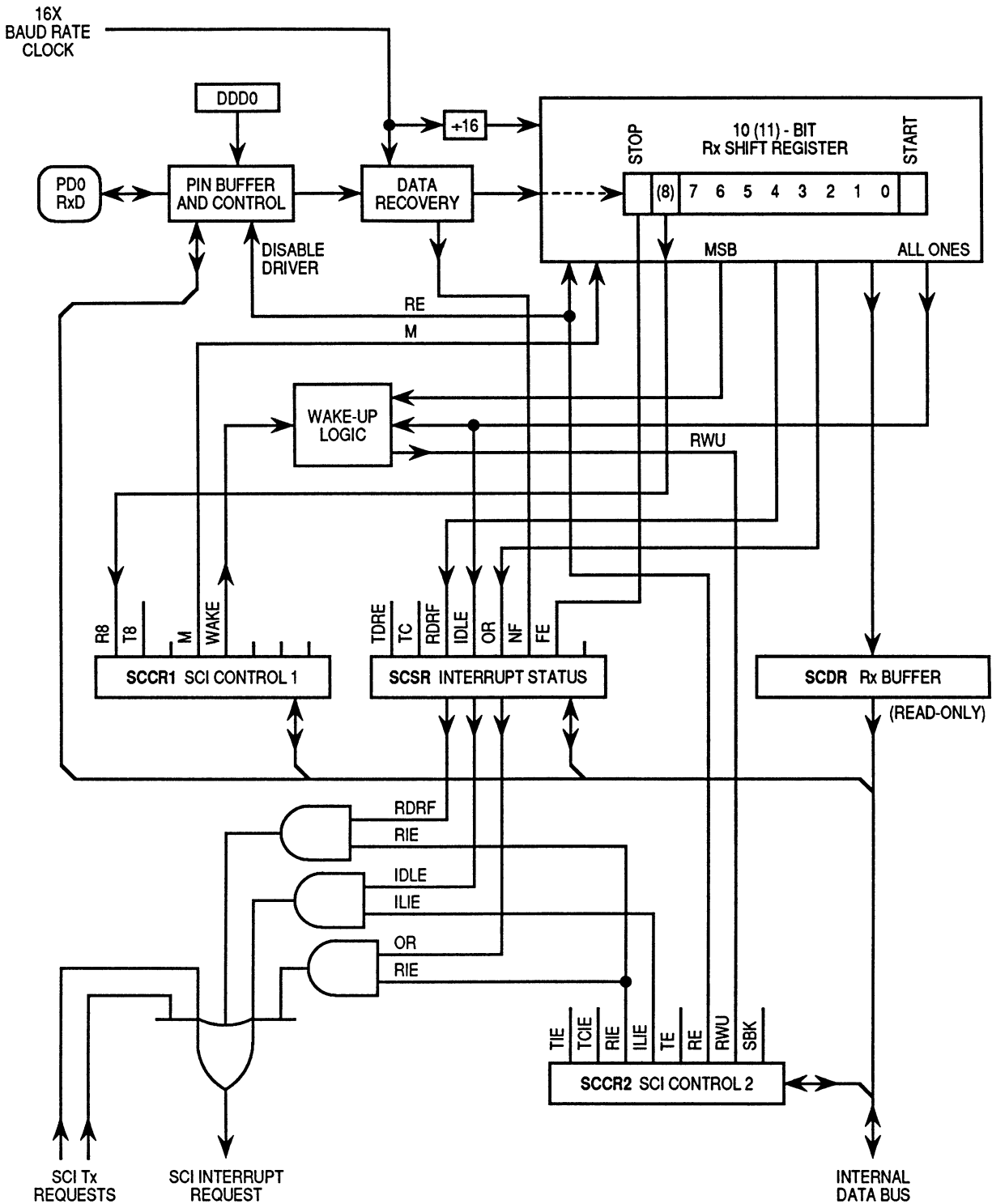

Figure 7-2. SCI Receiver Block Diagram

7.4 Wake-up Feature

The wake-up feature reduces SCI service overhead in multiple receiver systems. Software for each receiver evaluates the first character of each message. The receiver is placed in wakeup mode by writing a one to the RWU bit in the SCCR2 register. While RWU is one, all of the receiver-related status flags (RDRF, IDLE, OR, NF, and FE) are inhibited (cannot become set). Although RWU can be cleared by a software write to SCCR2, to do so would be unusual. Normally RWU is set by software and is cleared automatically with hardware. Whenever a new message begins, logic alerts the sleeping receivers to wake up and evaluate the initial character of the new message.

Two methods of wake-up are available: idle line wake-up and address mark wake-up. During idle line wake-up, a sleeping receiver awakens as soon as the RxD line becomes idle. In address mark wake-up, logic one in the most significant bit (MSB) of a character wakes up all sleeping receivers.

7.4.1 Idle-Line Wakeup

To use the receiver wake-up method, establish a software addressing scheme to allow the transmitting devices to direct a message to individual receivers or to groups of receivers. This addressing scheme can take any form as long as all transmitting and receiving devices are programmed to understand the same scheme. Because the addressing information is usually the first frame(s) in a message, receivers that are not part of the current task do not become burdened with the entire set of addressing frames. All receivers are awake (RWU = 0) when each message begins. As soon as a receiver determines that the message is not intended for it, software sets the RWU bit (RWU = 1), which inhibits further flag setting until the RxD line goes idle at the end of the message. As soon as an idle line is detected by receiver logic, hardware automatically clears the RWU bit so that the first frame of the next message can be received. This type of receiver wakeup requires a minimum of one idle-line frame time between messages, and no idle time between frames in a message.

7.4.2 Address-Mark Wakeup

The serial characters in this type of wakeup consist of seven (eight if $M = 1$) information bits and an MSB, which indicates an address character (when set to one — mark). The first character of each message is an addressing character (MSB = 1). All receivers in the system evaluate this character to determine if the remainder of the message is directed toward this particular receiver. As soon as a receiver determines that a message is not intended for it, the receiver activates the RWU function by using a software write to set the RWU bit. Because setting RWU inhibits receiver-related flags, there is no further software overhead for the rest of this message. When the next message begins, its first character has its MSB set, which automatically clears the RWU bit and enables

normal character reception. The first character whose MSB is set is also the first character to be received after wakeup because RWU gets cleared before the stop bit for that frame is serially received. This type of wakeup allows messages to include gaps of idle time, unlike the idle-line method, but there is a loss of efficiency because of the extra bit time for each character (address bit) required for all characters.

7.5 SCI Error Detection

Three error conditions, SCDR overrun, received bit noise, and framing can occur during generation of SCI system interrupts. Three bits (OR, NF, and FE) in the serial communications status register (SCSR) indicate if one of these error conditions exists. The overrun error (OR) bit is set when the next byte is ready to be transferred from the receive shift register to the SCDR and the SCDR is already full (RDRF bit is set). When an overrun error occurs, the data that caused the overrun is lost and the data that was already in SCDR is not disturbed. The OR is cleared when the SCSR is read (with OR set), followed by a read of the SCDR.

The noise flag (NF) bit is set if there is noise on any of the received bits, including the start and stop bits. The NF bit is not set until the RDRF flag is set. The NF bit is cleared when the SCSR is read (with FE equal to one) followed by a read of the SCDR.

When no stop bit was detected in the received data character, the framing error (FE) bit is set. FE is set at the same time as the RDRF. If the byte received causes both framing and overrun errors, the processor only recognizes the overrun error. The framing error flag inhibits further transfer of data into the SCDR until it is cleared. The FE bit is cleared when the SCSR is read (with FE equal to one) followed by a read of the SCDR.

7.6 SCI Registers

There are five addressable registers in the SCI.

7.6.1 Serial Communications Data Register

The serial communications data register (SCDR) is a parallel register that performs two functions. It is the receive data register when it is read, and the transmit data register when it is written. Reads access the receive data buffer and writes access the transmit data buffer. Receive and transmit are double buffered.

SCDR — SCI Data Register

\$102F

	Bit 7	6	5	4	3	2	1	Bit 0
	R7/T7	R6/T6	R5/T5	R4/T4	R3/T3	R2/T2	R1/T1	R0/T0
RESET:	U	U	U	U	U	U	U	U

7.6.2 Serial Communications Control Register 1

The serial communications control register 1 (SCCR1) provides the control bits that determine word length and select the method used for the wake-up feature.

SCCR1 — SCI Control Register 1

\$102C

	Bit 7	6	5	4	3	2	1	Bit 0
	R8	T8	0	M	WAKE	0	0	0
RESET:	U	U	0	0	0	0	0	0

R8 — Receive Data Bit 8

If the M bit is set, R8 stores the ninth bit in the receive data character.

T8 — Transmit Data bit 8

If the M bit is set, T8 stores the ninth bit in the transmit data character.

M — Mode (Select Character Format)

0 = Start bit, 8 data bits, 1 stop bit

1 = Start bit, 9 data bits, 1 stop bit

WAKE — Wake-up by Address Mark/Idle

0 = Wake-up by IDLE line recognition

1 = Wake-up by address mark (most significant data bit set)

7.6.3 Serial Communications Control Register 2

The serial communications control register 2 (SCCR2) provides the control bits that enable or disable individual SCI functions.

SCCR2 — SCI Control Register 2

\$102D

	Bit 7	6	5	4	3	2	1	Bit 0
	TIE	TCIE	RIE	ILIE	TE	RE	RWU	SBK
RESET:	0	0	0	0	0	0	0	0

TIE — Transmit Interrupt Enable

0 = TDRE interrupts disabled

1 = SCI interrupt requested when TDRE status flag is set

TCIE — Transmit Complete Interrupt Enable

0 = TC interrupts disabled

1 = SCI interrupt requested when TC status flag is set

RIE — Receiver Interrupt Enable

0 = RDRF and OR interrupts disabled

1 = SCI interrupt requested when RDRF flag or the OR status flag is set

ILIE — Idle Line Interrupt Enable

0 = IDLE interrupts disabled

1 = SCI interrupt requested when IDLE status flag is set

TE — Transmitter Enable

When TE goes from zero to one, one unit of idle character time (logic one) is queued as a preamble.

0 = Transmitter disabled

1 = Transmitter enabled

RE — Receiver Enable

0 = Receiver disabled

1 = Receiver enabled

RWU — Receiver Wake-Up Control

0 = Normal SCI receiver

1 = Wake-up enabled and receiver interrupts inhibited

SBK — Send Break

At least one character time of break is queued and sent each time SBK is written to one. More than one break may be sent if the transmitter is idle at the time the SBK bit is toggled on and off, as the baud rate clock edge could occur between writing the one and writing the zero to SBK.

0 = Break generator off

1 = Break codes generated as long as SBK = 1

7.6.4 Serial Communication Status Register

The serial communication status register (SCSR) provides inputs to the interrupt logic circuits for generation of the SCI system interrupt.

SCSR — SCI Status Register

\$102E

Bit 7	6	5	4	3	2	1	Bit 0
TDRE	TC	RDRF	IDLE	OR	NF	FE	0

RESET: 1 1 0 0 0 0 0 0

TDRE — Transmit Data Register Empty Flag

This flag is set when SCDR is empty. Clear the TDRE flag by reading SCSR with TDRE set and then writing to SCDR.

- 0 = SCDR busy
- 1 = SCDR empty

TC — Transmit Complete Flag

This flag is set when the transmitter is idle (no data, preamble, or break transmission in progress). Clear the TC flag by reading SCSR with TC set and then writing to SCDR.

- 0 = Transmitter busy
- 1 = Transmitter idle

RDRF — Receive Data Register Full Flag

This flag is set if a received character is ready to be read from SCDR. Clear the RDRF flag by reading SCSR with RDRF set and then reading SCDR.

- 0 = SCDR empty
- 1 = SCDR full

IDLE — Idle Line Detected Flag

This flag is set if the RxD line is idle. Once cleared, IDLE is not set again until the RxD line has been active and becomes idle again. The IDLE flag is inhibited when RWU = 1. Clear IDLE by reading SCSR with IDLE set and then reading SCDR.

- 0 = RxD line is active
- 1 = RxD line is idle

OR — Overrun Error Flag

OR is set if a new character is received before a previously received character is read from SCDR. Clear the OR flag by reading SCSR with OR set and then reading SCDR.

- 0 = No overrun
- 1 = Overrun detected

NF — Noise Error Flag

NF is set if majority sample logic detects anything other than a unanimous decision. Clear NF by reading SCSR with NF set and then reading SCDR.

- 0 = Unanimous decision
- 1 = Noise detected

FE — Framing Error

FE is set when a 0 is detected where a stop bit was expected. Clear the FE flag by reading SCSR with FE set and then reading SCDR.

- 0 = Stop bit detected
- 1 = 0 detected

7.6.5 Baud Rate Register

Use the baud rate register (BAUD) to select different baud rates for the SCI system. The SCP[1:0] bits function as a prescaler for the SCR[2:0] bits. Together, these five bits provide multiple baud rate combinations for a given crystal frequency. Normally, this register is written once during initialization. The prescaler is set to its fastest rate by default out of reset, and can be changed at any time. Refer to Tables 7–1 and 7–2 for normal baud rate selections.

BAUD — Baud Rate

\$102B

	Bit 7	6	5	4	3	2	1	Bit 0
	TCLR	0	SCP1	SCP0	RCKB	SCR2	SCR1	SCR0
RESET:	0	0	0	0	0	U	U	U

TCLR — Clear Baud Rate Counters (Test)

RCKB — SCI Baud Rate Clock Check (Test)

SCP1, SCP0 — SCI Baud Rate Prescaler Selects

These two bits select a prescale factor for the SCI baud rate generator that determines the highest possible baud rate.

Table 7–1. Baud Rate Prescale Selects

SCP[1:0]	Divide Internal Clock By	Crystal Frequency in MHz			
		4.0 MHz (Baud)	8.0 MHz (Baud)	10.0 MHz (Baud)	12.0 MHz (Baud)
00	1	62.50 K	125.0 K	156.25 K	187.5 K
01	3	20.83 K	41.67 K	52.08 K	62.5 K
10	4	15.625 K	31.25 K	38.4 K	46.88 K
11	13	4800	9600	12.02 K	14.42 K

SCR[2:0] — SCI Baud Rate Selects

These three bits select receiver and transmitter bit rate based on output from baud rate prescaler stage.

Table 7–2. Baud Rate Selects

SCR[2:0]	Divide Prescaler By	Highest Baud Rate (Prescaler Output from Previous Table)		
		4800	9600	38.4 K
000	1	4800	9600	38.4 K
001	2	2400	4800	19.2 K
010	4	1200	2400	9600
011	8	600	1200	4800
100	16	300	600	2400
101	32	150	300	1200
110	64	—	150	600
111	128	—	—	300

The prescale bits, SCP[1:0], determine the highest baud rate, and the SCR[2:0] bits select an additional binary submultiple ($\div 1$, $\div 2$, $\div 4$, through $\div 128$) of this highest baud rate. The result of these two dividers in series is the 16 X receiver baud rate clock. The SCR[2:0] bits are not affected by reset and can be changed at any time, although they should not be changed when any SCI transfer is in progress.

Figure 7–3 illustrates the SCI baud rate timing chain. The prescale select bits determine the highest baud rate. The rate select bits determine additional divide by two stages to arrive at the receiver timing (RT) clock rate. The baud rate clock is the result of dividing the RT clock by 16.

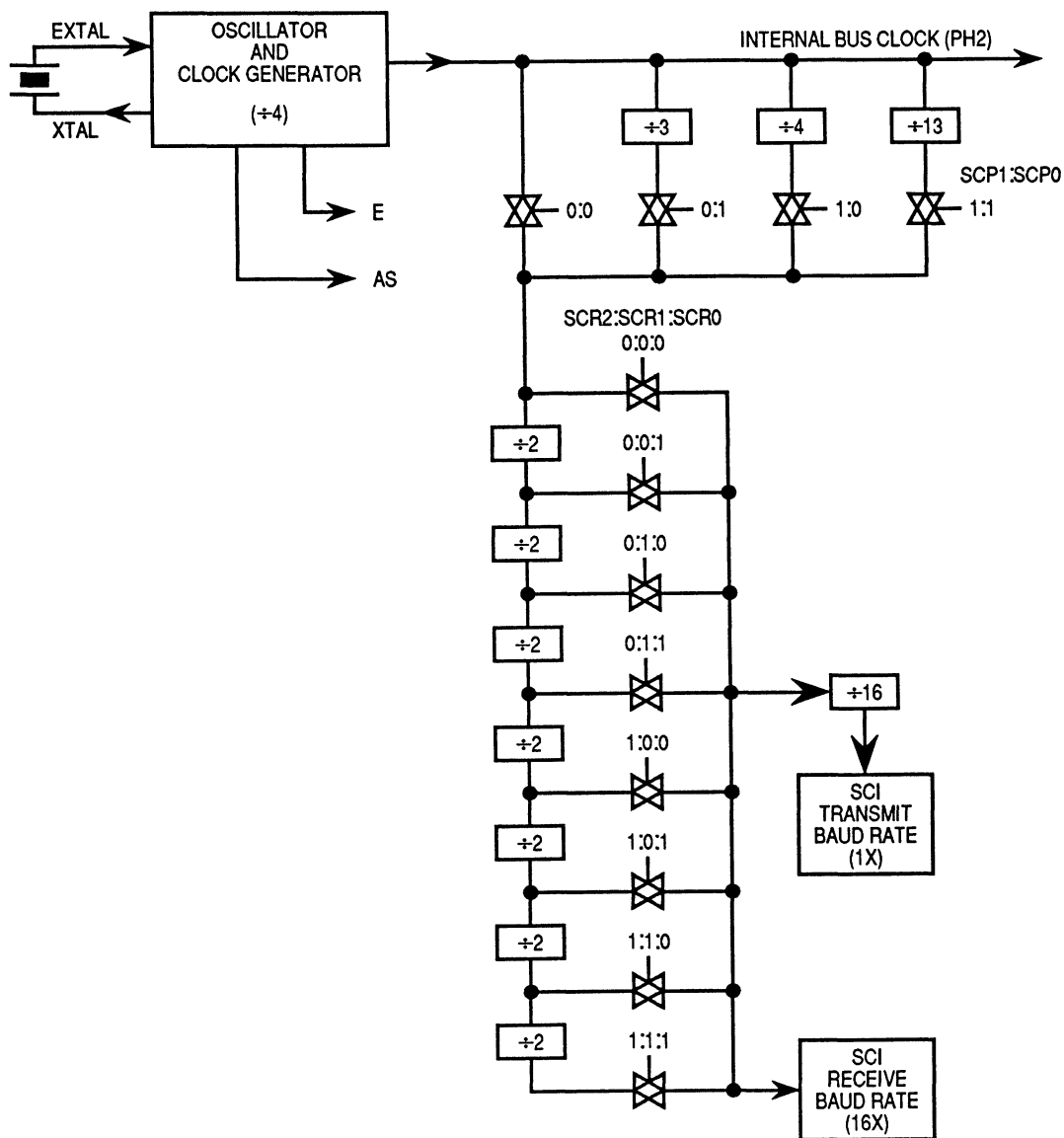

Figure 7–3. SCI Baud Rate Diagram

7.7 Status Flags and Interrupts

The SCI transmitter has two status flags. These status flags can be read by software (polled) to tell when the corresponding condition exists. Alternatively, a local interrupt enable bit can be set to enable each of these status conditions to generate interrupt requests when the corresponding condition is present. Status flags are automatically set by hardware logic conditions, but must be cleared by software, which provides an interlock mechanism that enables logic to know when software has noticed the status indication. The software clearing sequence for these flags is automatic — functions that are normally performed in response to the status flags also satisfy the conditions of the clearing sequence.

TDRE and TC flags are normally set when the transmitter is first enabled (TE set to one). The TDRE flag indicates there is room in the transmit queue to store another data character in the TDR. The TIE bit is the local interrupt mask for TDRE. When TIE is zero, TDRE must be polled. When TIE and TDRE are one, an interrupt is requested.

The TC flag indicates the transmitter has completed the queue. The TCIE bit is the local interrupt mask for TC. When TCIE is zero, TC must be polled; when TCIE is one and TC is one, an interrupt is requested.

Writing a zero to TE requests that the transmitter stop when it can. The transmitter completes any transmission in progress before actually shutting down. Only an MCU reset can cause the transmitter to stop and shut down immediately. If TE is written to zero when the transmitter is already idle, the pin reverts to its general-purpose I/O function (synchronized to the bit-rate clock). If anything is being transmitted when TE is written to zero, that character is completed before the pin reverts to general-purpose I/O, but any other characters waiting in the transmit queue are lost. The TC and TDRE flags are set at the completion of this last character, even though TE has been disabled.

The SCI receiver has five status flags, three of which can generate interrupt requests. The status flags are set by the SCI logic in response to specific conditions in the receiver. These flags can be read (polled) at any time by software. Refer to Figure 7–4, which shows SCI interrupt arbitration.

When an overrun takes place, the new character is lost, and the character that was in its way in the parallel RDR is undisturbed. RDRF is set when a character has been received and transferred into the parallel RDR. The OR flag is set instead of RDRF if overrun occurs. A new character is ready to be transferred into RDR before a previous character is read from RDR.

The NF and FE flags provide additional information about the character in the RDR, but do not generate interrupt requests.

The last receiver status flag and interrupt source come from the IDLE flag. The RxD line is idle if it has constantly been at logic one for a full character time. The IDLE flag is set only after the RxD line has been busy and becomes idle, which prevents repeated interrupts for the whole time RxD remains idle.

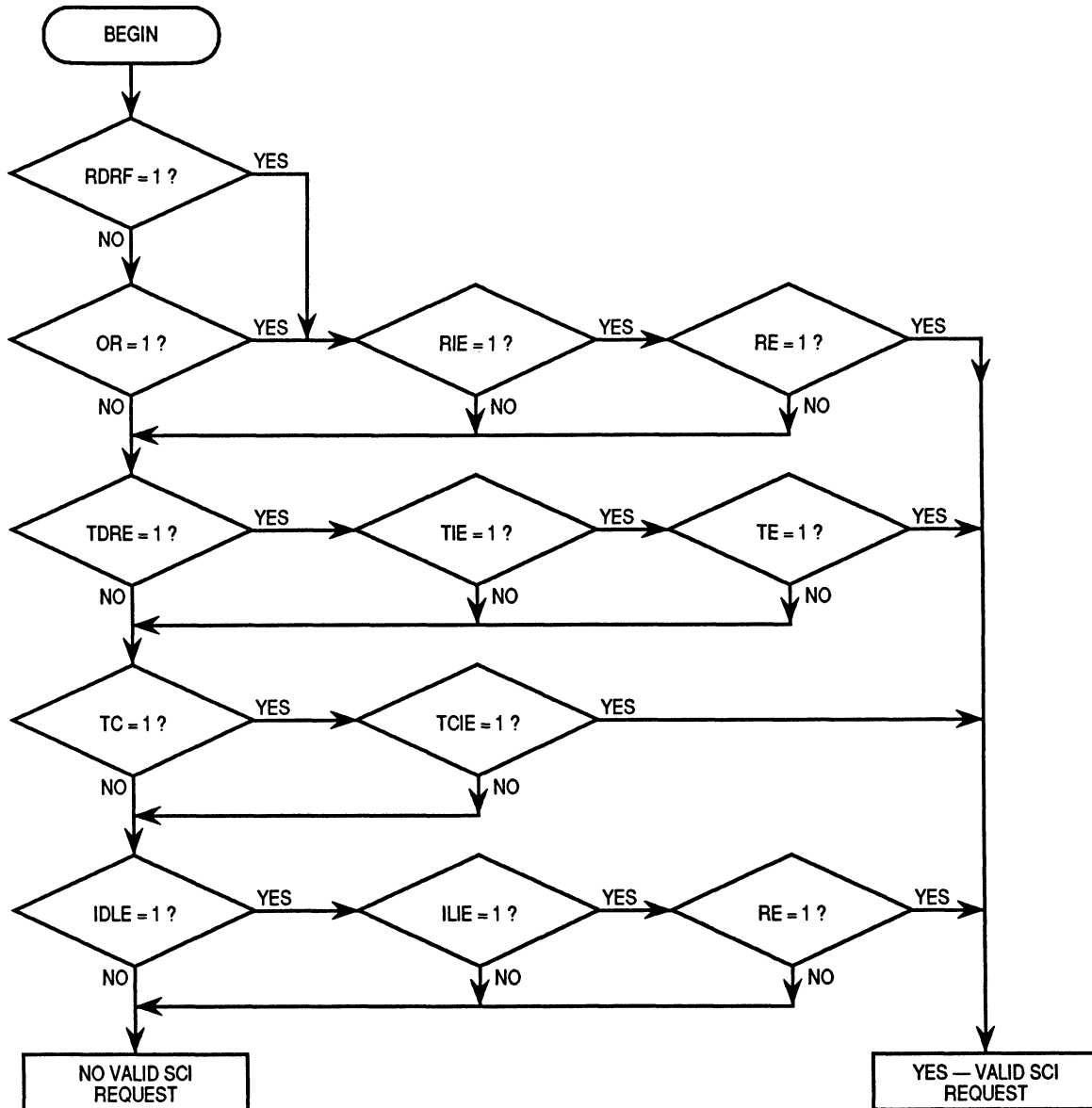

Figure 7-4. Interrupt Source Resolution Within SCI

SECTION 8

SERIAL PERIPHERAL INTERFACE

The serial peripheral interface (SPI), an independent serial communications subsystem, allows the MCU to communicate synchronously with peripheral devices, such as transistor-transistor logic (TTL) shift registers, liquid crystal diode (LCD) display drivers, analog-to-digital converter subsystems, and other microprocessors. The SPI is also capable of interprocessor communication in a multiple master system. The SPI system can be configured as either a master or a slave device with data rates as high as one half of the E-clock rate when configured as master, and as fast as the E-clock rate when configured as slave.

8.1 Functional Description

The central element in the SPI system is the block containing the shift register and the read data buffer. The system is single buffered in the transmit direction and double buffered in the receive direction. This means that new data for transmission cannot be written to the shifter until the previous transfer is complete; however, received data is transferred into a parallel read data buffer so the shifter is free to accept a second serial character. As long as the first character is read out of the read data buffer before the next serial character is ready to be transferred, no overrun condition occurs. A single MCU register address is used for reading data from the read data buffer, and for writing data to the shifter.

The SPI status block represents the SPI status functions (transfer complete, write collision, and mode fault) performed by the serial peripheral status register (SPSR). The SPI control block represents those functions that control the SPI system through the serial peripheral control register (SPCR).

Refer to Figure 8–1, which shows the SPI block diagram.

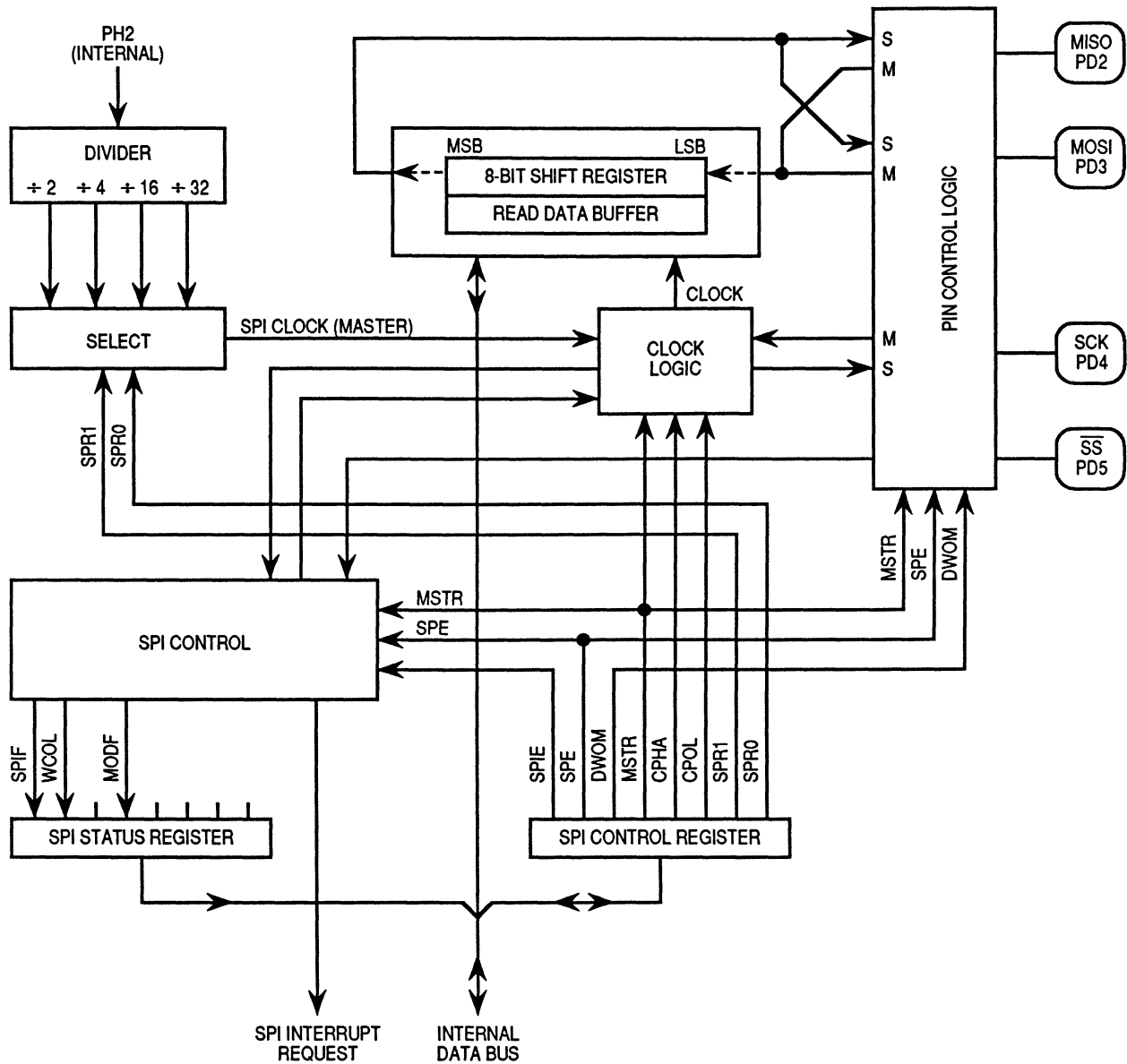

Figure 8-1. SPI Block Diagram

8.2 SPI Transfer Formats

During an SPI transfer, data is simultaneously transmitted and received. A serial clock line synchronizes shifting and sampling of the information on the two serial data lines. A slave select line allows individual selection of a slave SPI device; slave devices that are not selected do not interfere with SPI bus activities. On a master SPI device, the select line can optionally be used to indicate a multiple master bus contention. Refer to Figure 8-2.

SECTION 8

SERIAL PERIPHERAL INTERFACE

The serial peripheral interface (SPI), an independent serial communications subsystem, allows the MCU to communicate synchronously with peripheral devices, such as transistor-transistor logic (TTL) shift registers, liquid crystal diode (LCD) display drivers, analog-to-digital converter subsystems, and other microprocessors. The SPI is also capable of interprocessor communication in a multiple master system. The SPI system can be configured as either a master or a slave device with data rates as high as one half of the E-clock rate when configured as master, and as fast as the E-clock rate when configured as slave.

8.1 Functional Description

The central element in the SPI system is the block containing the shift register and the read data buffer. The system is single buffered in the transmit direction and double buffered in the receive direction. This means that new data for transmission cannot be written to the shifter until the previous transfer is complete; however, received data is transferred into a parallel read data buffer so the shifter is free to accept a second serial character. As long as the first character is read out of the read data buffer before the next serial character is ready to be transferred, no overrun condition occurs. A single MCU register address is used for reading data from the read data buffer, and for writing data to the shifter.

The SPI status block represents the SPI status functions (transfer complete, write collision, and mode fault) performed by the serial peripheral status register (SPSR). The SPI control block represents those functions that control the SPI system through the serial peripheral control register (SPCR).

Refer to Figure 8–1, which shows the SPI block diagram.

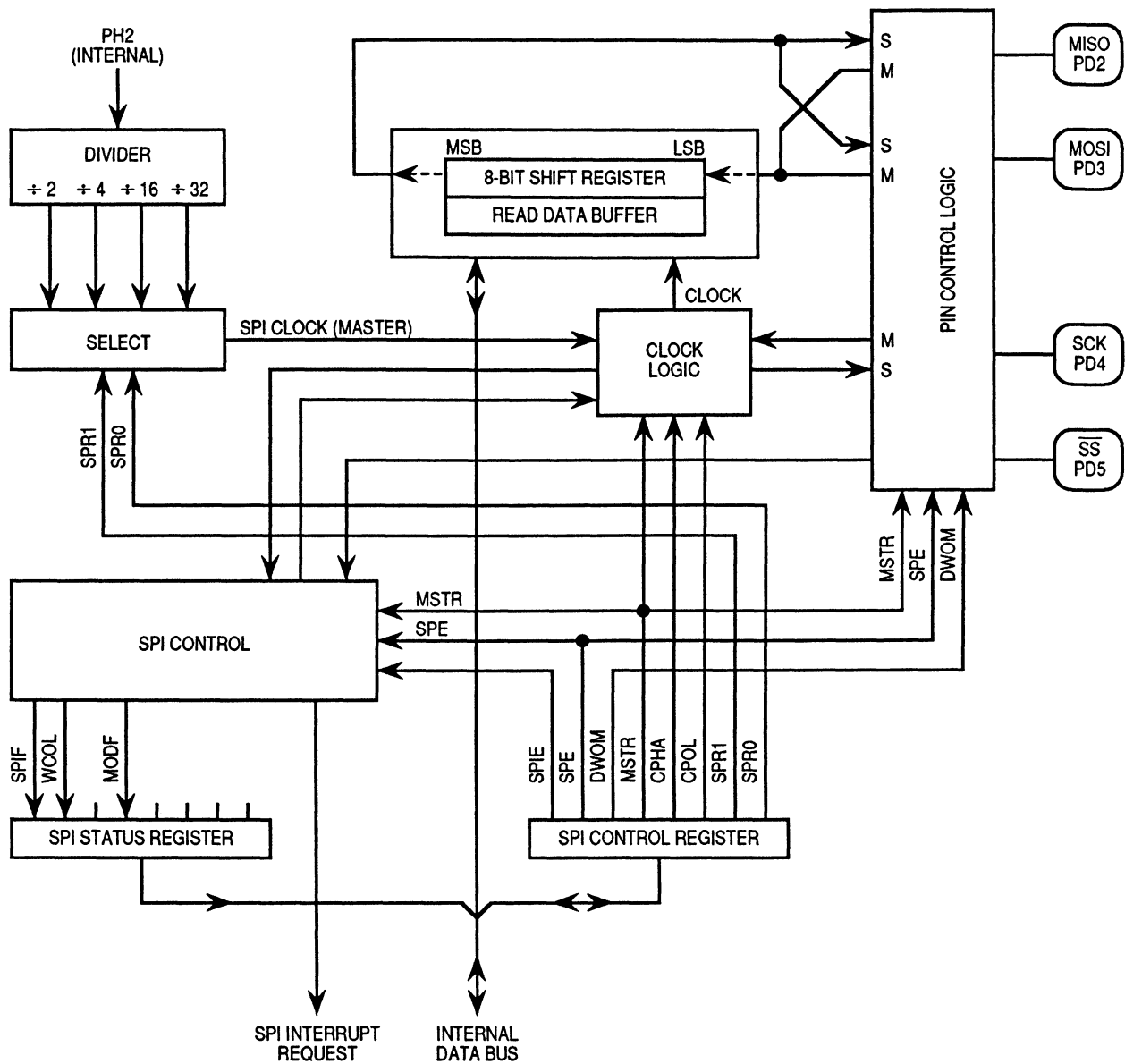

Figure 8-1. SPI Block Diagram

8.2 SPI Transfer Formats

During an SPI transfer, data is simultaneously transmitted and received. A serial clock line synchronizes shifting and sampling of the information on the two serial data lines. A slave select line allows individual selection of a slave SPI device; slave devices that are not selected do not interfere with SPI bus activities. On a master SPI device, the select line can optionally be used to indicate a multiple master bus contention. Refer to Figure 8-2.

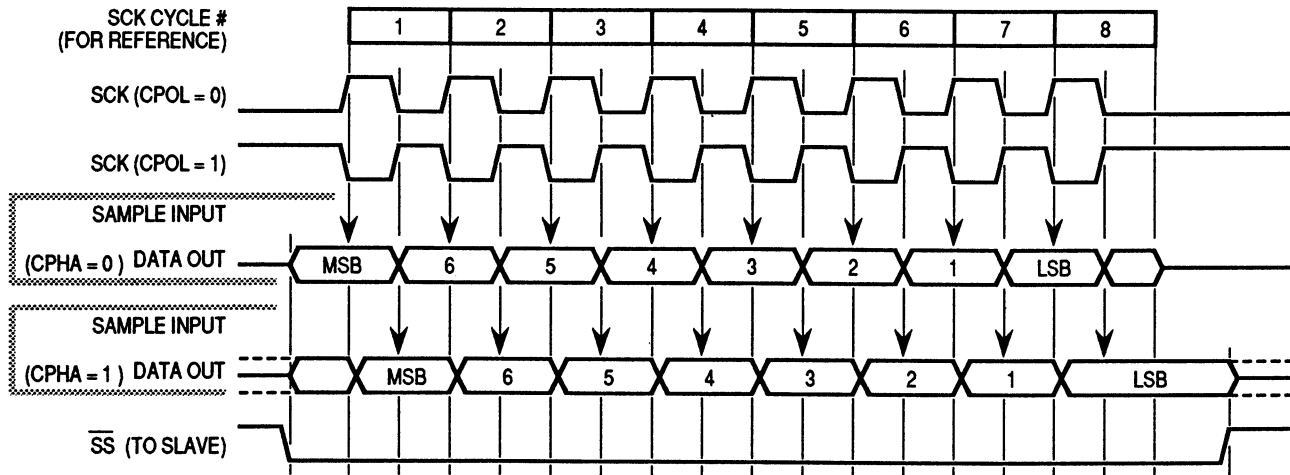

Figure 8–2. SPI Transfer Format

8.2.1 Clock Phase and Polarity Controls

Software can select one of four combinations of serial clock phase and polarity using two bits in the SPI control register (SPCR). The clock polarity is specified by the CPOL control bit, which selects an active high or active low clock, and has no significant effect on the transfer format. The clock phase (CPHA) control bit selects one of two different transfer formats. The clock phase and polarity should be identical for the master SPI device and the communicating slave device. In some cases, the phase and polarity are changed between transfers to allow a master device to communicate with peripheral slaves having different requirements.

When CPHA equals zero, the slave select (\overline{SS}) line must be deasserted and reasserted between each successive serial byte. Also, if the slave writes data to the SPI data register (SPDR) while \overline{SS} is active low, a write collision error results.

When CPHA equals one, the \overline{SS} line can remain low between successive transfers.

8.3 SPI Signals

The following paragraphs contain descriptions of the four SPI signals: master in slave out (MISO), master out slave in (MOSI), serial clock (SCK), and \overline{SS} .

8.3.1 Master In Slave Out

MISO is one of two unidirectional serial data signals. It is an input to a master device and an output from a slave device. The MISO line of a slave device is placed in the high impedance state if the slave device is not selected.

8.3.2 Master Out Slave In

The MOSI line is the second of the two unidirectional serial data signals. It is an output from a master device and an input to a slave device. The master device places data on the MOSI line a half-cycle before the clock edge that the slave device uses to latch the data.

8.3.3 Serial Clock

SCK, an input to a slave device, is generated by the master device and synchronizes data movement in and out of the device through the MOSI and MISO lines. Master and slave devices are capable of exchanging a byte of information during a sequence of eight clock cycles.

There are four possible timing relationships that can be chosen by using control bits CPOL and CPHA in the serial peripheral control register (SPCR). Both master and slave devices must operate with the same timing. The SPI clock rate select bits, SPR[1:0], in the SPCR of the master device, select the clock rate. In a slave device, SPR[1:0] have no effect on the operation of the SPI.

8.3.4 Slave Select

The \overline{SS} input of a slave device must be externally asserted before a master device can exchange data with the slave device. \overline{SS} must be low before data transactions and must stay low for the duration of the transaction.

The \overline{SS} line of the master must be held high. If it goes low, a mode fault error flag (MODF) is set in the serial peripheral status register (SPSR). To disable the mode fault circuit, write a one in bit 5 of the port D data direction register. This sets the \overline{SS} pin to act as a general-purpose output. The other three lines are dedicated to the SPI whenever the serial peripheral interface is on.

The state of the master and slave CPHA bits affects the operation of \overline{SS} . CPHA settings should be identical for master and slave. When CPHA = 0, the shift clock is the OR of \overline{SS} with SCK. In this clock phase mode, \overline{SS} must go high between successive characters in an SPI message. When CPHA = 1, \overline{SS} can be left low between successive SPI characters. In cases where there is only one SPI slave MCU, its \overline{SS} line can be tied to V_{SS} as long as only CPHA = 1 clock mode is used.

8.4 SPI System Errors

Two system errors can be detected by the SPI system. The first type of error arises in a multiple-master system when more than one SPI device simultaneously tries to be a master. This error is called a mode fault. The second type of error, write collision, indicates that an attempt was made to write data to the SPDR while a transfer was in progress.

When the SPI system is configured as a master and the \overline{SS} input line goes to active low, a mode fault error has occurred — usually because two devices have attempted to act as master at the same time. In cases where more than one device is concurrently configured as a master, there is a chance of contention between two pin drivers. For push-pull CMOS drivers, this contention can cause permanent damage. The mode fault attempts to protect the device by disabling the drivers. The MSTR control bit in the SPCR and all four DDRD control bits associated with the SPI are cleared and an interrupt is generated subject to masking by the SPIE control bit and the I bit in the CCR.

Other precautions may need to be taken to prevent driver damage. If two devices are made masters at the same time, mode fault does not help protect either one unless one of them selects the other as slave. The amount of damage possible depends on the length of time both devices attempt to act as master.

A write collision error occurs if the SPDR is written while a transfer is in progress. Because the SPDR is not double buffered in the transmit direction, writes to SPDR cause data to be written directly into the SPI shift register. Because this write corrupts any transfer in progress, a write collision error is generated. The transfer continues undisturbed, and the write data that caused the error is not written to the shifter.

A write collision is normally a slave error because a slave has no control over when a master initiates a transfer. A master knows when a transfer is in progress, so there is no reason for a master to generate a write-collision error, although the SPI logic can detect write collisions in both master and slave devices.

The SPI configuration determines the characteristics of a transfer in progress. For a master, a transfer begins when data is written to SPDR and ends when SPIF is set. For a slave with CPHA equal to zero, a transfer starts when \overline{SS} goes low and ends when \overline{SS} returns high. In this case, SPIF is set at the middle of the eighth SCK cycle when data is transferred from the shifter to the parallel data register, but the transfer is still in progress until \overline{SS} goes high. For a slave with CPHA equal to one, transfer begins when the SCK line goes to its active level, which is the edge at the beginning of the first SCK cycle. The transfer ends in a slave in which CPHA equals one when SPIF is set. For a slave, after

a byte transfer, SCK must be in an inactive state for at least 2 E-clock cycles before the next byte transfer begins.

8.5 SPI Registers

The three SPI registers, SPCR, SPSR, and SPDR, provide control, status, and data storage functions. Refer to the following information for a description of how these registers are organized.

8.5.1 Serial Peripheral Control

SPCR — Serial Peripheral Control Register

\$1028

	Bit 7	6	5	4	3	2	1	Bit 0
	SPIE	SPE	DWOM	MSTR	CPOL	CPHA	SPR1	SPR0
RESET:	0	0	0	0	0	1	U	U

SPIE — Serial Peripheral Interrupt Enable

0 = SPI interrupt disabled

1 = SPI interrupt enabled

SPE — Serial Peripheral System Enable

0 = SPI off

1 = SPI on

DWOM — Port D Wired-OR Mode

DWOM affects all six port D pins.

0 = Normal CMOS outputs

1 = Open-drain outputs

MSTR — Master Mode Select

0 = Slave mode

1 = Master mode

CPOL — Clock Polarity

When the clock polarity bit is cleared and data is not being transferred, the SCK pin of the master device has a steady state low value. When CPOL is set, SCK idles high. Refer to Figure 8–2 and **8.2.1 Clock Phase and Polarity Controls**.

CPHA — Clock Phase

The clock phase bit, in conjunction with the CPOL bit, controls the clock-data relationship between master and slave. The CPHA bit selects one of two different clocking protocols. Refer to Figure 8–2 and **8.2.1 Clock Phase and Polarity Controls**.

SPR1 and SPR0 — SPI Clock Rate Selects

These two serial peripheral rate bits select one of four baud rates to be used as SCK if the device is a master; however, they have no effect in the slave mode.

SPR[1:0]	E Clock Divide By	Frequency at E = 2 MHz (Baud)
00	2	1.0 MHz
01	4	500 kHz
10	16	125 kHz
11	32	62.5 kHz

8.5.2 Serial Peripheral Status

SPSR — Serial Peripheral Status Register

\$1029

	Bit 7	6	5	4	3	2	1	Bit 0
	SPIF	WCOL	0	MODF	0	0	0	0
RESET:	0	0	0	0	0	0	0	0

SPIF — SPI Transfer Complete Flag

SPIF is set upon completion of data transfer between the processor and the external device. If SPIF goes high, and if SPIE is set, a serial peripheral interrupt is generated. To clear the SPIF bit, read the SPSR with SPIF set, then access the SPDR. Unless SPSR is read (with SPIF set) first, attempts to write SPDR are inhibited.

WCOL — Write Collision

Clearing the WCOL bit is accomplished by reading the SPSR (with WCOL set) followed by an access of SPDR. Refer to **8.3.4 Slave Select** and **8.4 System Errors**.

0 = No write collision

1 = Write collision

Bit 5 — Not implemented

Always reads zero

MODF — Mode Fault

To clear the MODF bit, read the SPSR (with MODF set), then write to the SPCR. Refer to **8.3.4 Slave Select** and **8.4 System Errors**.

0 = No mode fault

1 = Mode fault

Bits [3:0] — Not implemented

Always read zero

8.5.3 Serial Peripheral Data I/O

The SPDR is used when transmitting or receiving data on the serial bus. Only a write to this register initiates transmission or reception of a byte, and this only occurs in the master device. At the completion of transferring a byte of data, the SPIF status bit is set in both the master and slave devices.

A read of the SPDR is actually a read of a buffer. To prevent an overrun and the loss of the byte that caused the overrun, the first SPIF must be cleared by the time a second transfer of data from the shift register to the read buffer is initiated.

SPI is double buffered in and single buffered out.

SPDR — SPI Data Register

\$102A

Bit 7	6	5	4	3	2	1	Bit 0
Bit 7	6	5	4	3	2	1	Bit 0

SECTION 9 TIMING SYSTEM

The M68HC11 timing system is composed of five clock divider chains. The main clock divider chain includes a 16-bit free-running counter, which is driven by a programmable prescaler. The main timer's programmable prescaler provides one of the four clocking rates to drive the 16-bit counter. Two prescaler control bits select the prescale rate.

The prescaler output divides the system clock by 1, 4, 8, or 16. Taps off of this main clocking chain drive circuitry that generates the slower clocks used by the pulse accumulator, the real-time interrupt (RTI), and the computer operating properly (COP) watchdog subsystems, also described in this section. Refer to Figure 9-1.

All main timer system activities are referenced to this free-running counter. The counter begins incrementing from \$0000 as the MCU comes out of reset, and continues to the maximum count, \$FFFF. At the maximum count, the counter rolls over to \$0000, sets an overflow flag, and continues to increment. As long as the MCU is running in a normal operating mode, there is no way to reset, change, or interrupt the counting. The capture/compare subsystem features three input capture channels, four output compare channels, and one channel that can be selected to perform either input capture or output compare. Each of the three input capture functions has its own 16-bit input capture register (time capture latch) and each of the output compare functions has its own 16-bit compare register. All timer functions, including the timer overflow and RTI, have their own interrupt controls and separate interrupt vectors.

The pulse accumulator contains an 8-bit counter and edge select logic. The pulse accumulator can operate in either event counting mode or gated time accumulation mode. During event counting mode, the pulse accumulator's 8-bit counter increments when a specified edge is detected on an input signal. During gated time accumulation mode, an internal clock source increments the 8-bit counter while an input signal has a predetermined logic level.

The real-time interrupt (RTI) is a programmable periodic interrupt circuit that permits pacing the execution of software routines by selecting one of four interrupt rates.

The COP watchdog clock input ($E+2^{15}$) is tapped off of the free-running counter chain. The COP automatically times out unless it is serviced within a specific time by a program reset sequence. If the COP is allowed to time out, a reset is generated, which drives the $\overline{\text{RESET}}$ pin low to reset the MCU and the external system. Refer to Table 9–1 for crystal-related frequencies and periods.

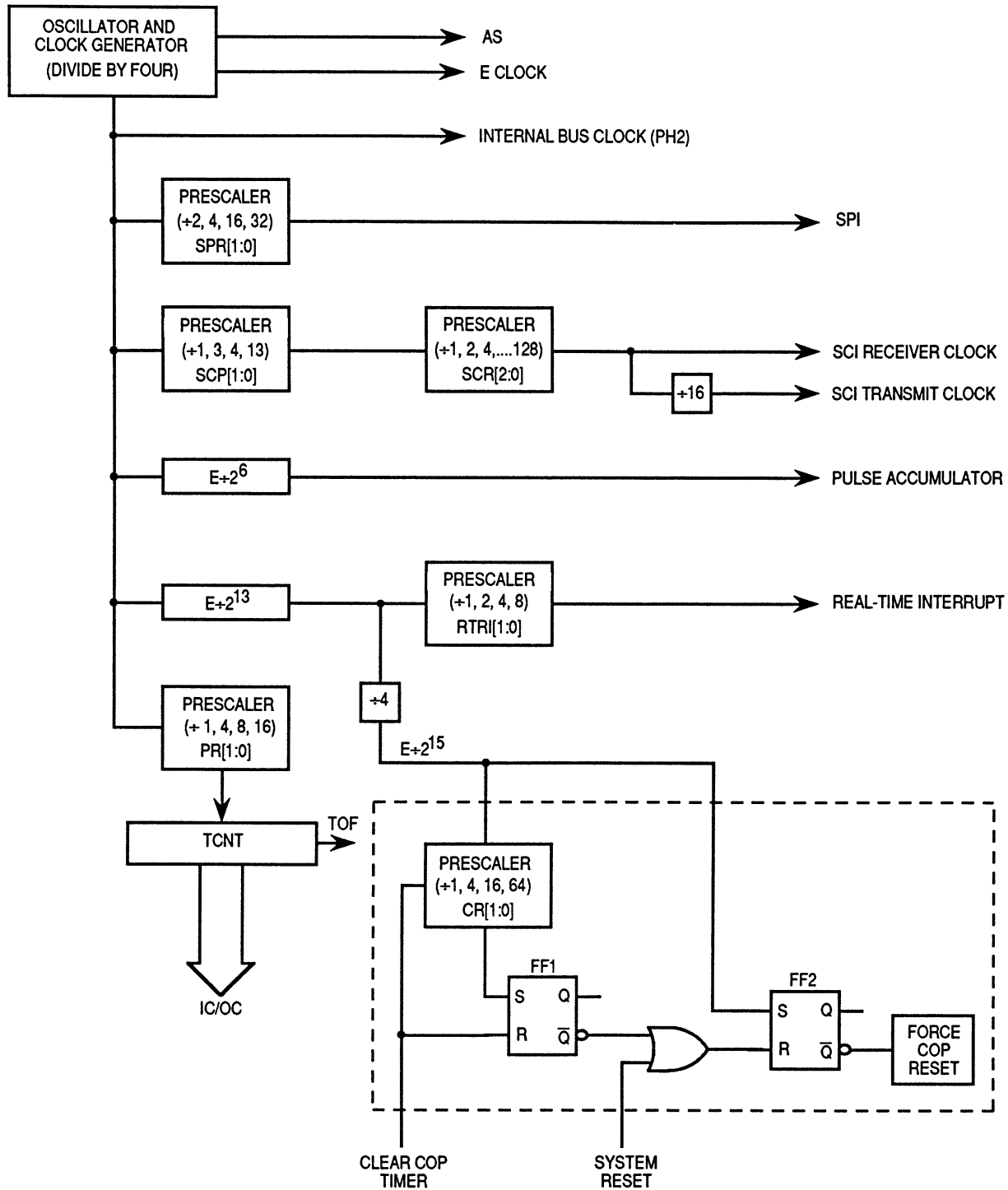

Figure 9–1. Timer Clock Divider Chains

Table 9–1. Timer Summary

Control Bits	XTAL Frequencies			
	4.0 MHz	8.0 MHz	12.0 MHz	Other Rates
	1.0 MHz	2.0 MHz	3.0 MHz	(E)
	1000 ns	500 ns	333 ns	(1/E)
PR[1:0]	Main Timer Count Rates			
0 0 1 count — overflow —	1.0 μ s 65.536 ms	500 ns 32.768 ms	333 ns 21.845 ms	(E/1) (E/2 ¹⁶)
0 1 1 count — overflow —	4.0 μ s 262.14 ms	2.0 μ s 131.07 ms	1.333 μ s 87.381 ms	(E/4) (E/2 ¹⁸)
1 0 1 count — overflow —	8.0 μ s 524.29 ms	4.0 μ s 262.14 ms	2.667 μ s 174.76 ms	(E/8) (E/2 ¹⁹)
1 1 1 count — overflow —	16.0 μ s 1.049 s	8.0 μ s 524.29 ms	5.333 μ s 349.52 ms	(E/16) (E/2 ²⁰)

9.1 Timer Structure

Figure 9–2 shows the capture/compare system block diagram. The port A pin control block includes logic for timer functions and for general-purpose I/O. For pins PA2, PA1, and PA0, this block contains both the edge-detection logic and the control logic that enables the selection of which edge triggers an input capture. The digital level on PA2–PA0 can be read at any time (read PORTA register), even if the pin is being used for the input capture function. Pins PA6–PA3 are used for either general-purpose output, or as output compare pins. When one of these pins is being used for an output compare function, it cannot be written directly as if it were a general-purpose output. Each of the output compare functions (OC5–OC2) is related to one of the port A output pins. Output compare one (OC1) has extra control logic, allowing it optional control of any combination of the PA7–PA3 pins. The PA7 pin can be used as a general-purpose I/O pin, as an input to the pulse accumulator, or as an OC1 output pin.

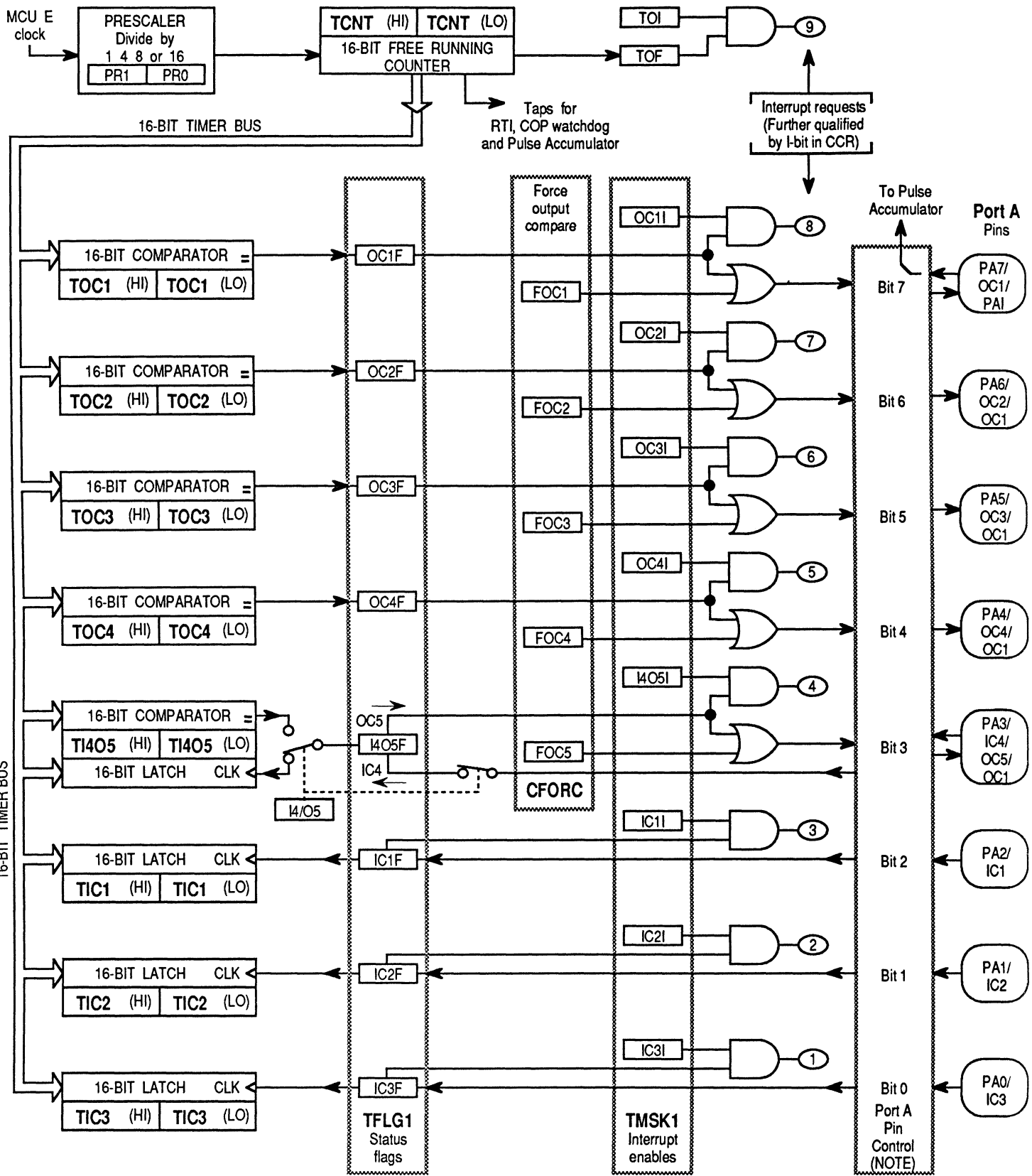

Figure 9-2. Capture/Compare Block Diagram

9.2 Input Capture

The input capture function records the time an external event occurs by latching the value of the free-running counter when a selected edge is detected at the associated timer input pin. Software can store latched values and use them to compute the periodicity and duration of events. For example, by storing the times of successive edges of an incoming signal, software can determine the period and pulse width of a signal. To measure period, two successive edges of the same polarity are captured. To measure pulse width, two alternate polarity edges are captured.

In most cases, input capture edges are asynchronous to the internal timer counter, which is clocked relative to the PH2 clock. These asynchronous capture requests are synchronized to PH2 so that the latching occurs on the opposite half cycle of PH2 from when the timer counter is being incremented. This synchronization process introduces a delay from when the edge occurs to when the counter value is detected. Because these delays offset each other when the time between two edges is being measured, the delay can be ignored. When an input capture is being used with an output compare, there is a similar delay between the actual compare point and when the output pin changes state.

The control and status bits that implement the input capture functions are contained in the PACTL, TCTL2, TMSK1, and TFLG1 registers.

To configure port A bit 3 as an input capture, clear the DDRA3 bit of the PACTL register. Note that this bit is cleared out of reset. To enable PA3 as the fourth input capture, set the I4/O5 bit in the PACTL register. Otherwise, PA3 is configured as a fifth output compare out of reset, with bit I4/O5 being cleared. If the DDRA3 bit is set (configuring PA3 as an output), and IC4 is enabled, then writes to PA3 cause edges on the pin to result in input captures. Writing to TI4/O5 has no effect when the TI4/O5 register is acting as IC4.

9.2.1 Timer Control 2 Register

Use the control bits of this register to program input capture functions to detect a particular edge polarity on the corresponding timer input pin. Each of the input capture functions can be independently configured to detect rising edges only, falling edges only, any edge (rising or falling), or to disable the input capture function. The input capture functions operate independently of each other and can capture the same TCNT value if the input edges are detected within the same timer count cycle.

	Bit 7	6	5	4	3	2	1	Bit 0
	EDG4B	EDG4A	EDG1B	EDG1A	EDG2B	EDG2A	EDG3B	EDG3A
RESET:	0	0	0	0	0	0	0	0

EDGxB and EDGxA — Input Capture Edge Control

There are four pairs of these bits. Each pair is cleared to zero by reset and must be encoded to configure the corresponding input capture edge detector circuit. IC4 functions only if the I4/O5 bit in the PACTL register is set. Refer to Table 9–2.

Table 9–2. Timer Control Configuration

EDGxB	EDGxA	Configuration
0	0	Capture disabled
0	1	Capture on rising edges only
1	0	Capture on falling edges only
1	1	Capture on any edge

9.2.2 Timer Input Capture Registers

When an edge has been detected and synchronized, the 16-bit free-running counter value is transferred into the input capture register pair as a single 16-bit parallel transfer. Timer counter value captures and timer counter incrementing occur on opposite half-cycles of the phase 2 clock so that the count value is stable whenever a capture occurs. The TICx registers are not affected by reset. Input capture values can be read from a pair of 8-bit read-only registers. A read of the high-order byte of an input capture register pair inhibits a new capture transfer for one bus cycle. If a double-byte read instruction, such as LDD, is used to read the captured value, coherency is assured. When a new input capture occurs immediately after a high-order byte read, transfer is delayed for an additional cycle but the value is not lost.

TIC1–TIC3 — Timer Input Capture

\$1010–\$1015

\$1010	Bit 15	14	13	12	11	10	9	Bit 8	TIC1 (High)
\$1011	Bit 7	6	5	4	3	2	1	Bit 0	TIC1 (Low)
\$1012	Bit 15	14	13	12	11	10	9	Bit 8	TIC2 (High)
\$1013	Bit 7	6	5	4	3	2	1	Bit 0	TIC2 (Low)
\$1014	Bit 15	14	13	12	11	10	9	Bit 8	TIC3 (High)
\$1015	Bit 7	6	5	4	3	2	1	Bit 0	TIC3 (Low)

RESET: Input capture registers not affected by reset.

9.2.3 Timer Input Capture 4/Output Compare 5 Register

Use TI4/O5 as either an input capture register or an output compare register, depending on the function chosen for the I4/O5 pin. To enable it as an input capture pin, set the I4/O5 bit in the pulse accumulator control register (PACTL) to logic level one. To use it as an output compare register, set the I4/O5 bit to a logic level zero. Refer to **9.6 Pulse Accumulator**.

TI4/O5 — Timer Input Capture 4/Output Compare 5

\$101E, \$101F

\$101E	Bit 15	14	13	12	11	10	9	Bit 8	TI4/O5 (High)
\$101F	Bit 7	6	5	4	3	2	1	Bit 0	TI4/O5 (Low)

RESET: TI4/O5 register resets to ones (\$FFFF)

9.3 Output Compare

Use the output compare (OC) function to program an action to occur at a specific time — when the 16-bit counter reaches a specified value. For each of the five output compare functions, there is a separate 16-bit compare register and a dedicated 16-bit comparator. The value in the compare register is compared to the value of the free-running counter on every bus cycle. When the compare register matches the counter value, an output compare status flag is set. The flag can be used to initiate the automatic actions for that output compare function.

To produce a pulse of a specific duration, write to the output compare register a value representing the time the leading edge of the pulse is to occur. The output compare circuit is configured to set the appropriate output either high or low, depending on the polarity of the pulse being produced. After a match occurs, the output compare register is reprogrammed to change the output pin back to its inactive level at the next match. A value representing the width of the pulse is added to the original value and then written to the output compare register. Because the pin state changes occur at specific values of the free-running counter, the pulse width can be controlled accurately at the resolution of the free-running counter, independent of software latencies. To generate an output signal of a specific frequency and duty cycle, repeat this pulse-generating procedure.

There are four 16-bit read/write output compare registers: TOC1, TOC2, TOC3, and TOC4, and the TI4/O5 register, which functions under software control as either IC4 or OC5. Each of the OC registers is set to \$FFFF on reset. A value written to an OC register is compared to the free-running counter value during each E-clock cycle. If a match is found, the particular output compare flag is set in timer interrupt flag 1 (TFLG1) register. If that particular interrupt is enabled in the timer interrupt mask 1 (TMSK1) register, an interrupt is generated. In

addition to an interrupt, a specified action can be initiated at one or more timer output pins. For OC5–OC2, the pin action is controlled by pairs of bits (OMx and OLx) in the TCTL1 register. The output action is taken on each successful compare, regardless of whether or not the OCxF flag in the TFLG1 register was previously cleared.

OC1 is different from the other output compares in that a successful OC1 compare can affect any or all five of the OC pins. The OC1 output action taken when a match is found is controlled by two 8-bit registers with three bits unimplemented: the output compare 1 mask register, OC1M, and the output compare 1 data register, OC1D. OC1M specifies which port A outputs are to be used, and OC1D specifies what data is placed on these port pins.

9.3.1 Timer Output Compare Registers

All output compare registers are 16-bit read-write. Each is initialized to \$FFFF at reset. If an output compare register is not used for an output compare function, it can be used as a storage location. A write to the high-order byte of an output compare register pair inhibits the output compare function for one bus cycle. This inhibition prevents inappropriate subsequent comparisons. Coherency requires a complete 16-bit read or write. However, if coherency is not needed, byte accesses can be used.

For output compare functions, write a comparison value to output compare registers TOC1–TOC4 and TI4/O5. When TCNT value matches the comparison value, specified pin actions occur.

TOC1–TOC4 — Timer Output Compare

\$1016–\$101D

\$1016	Bit 15	14	13	12	11	10	9	Bit 8	TOC1 (High)
\$1017	Bit 7	6	5	4	3	2	1	Bit 0	TOC1 (Low)
\$1018	Bit 15	14	13	12	11	10	9	Bit 8	TOC2 (High)
\$1019	Bit 7	6	5	4	3	2	1	Bit 0	TOC2 (Low)
\$101A	Bit 15	14	13	12	11	10	9	Bit 8	TOC3 (High)
\$101B	Bit 7	6	5	4	3	2	1	Bit 0	TOC3 (Low)
\$101C	Bit 15	14	13	12	11	10	9	Bit 8	TOC4 (High)
\$101D	Bit 7	6	5	4	3	2	1	Bit 0	TOC4 (Low)

All TOCx register pairs reset to ones (\$FFFF).

TI4/O5 — Timer Input Capture 4/Output Compare 5

\$101E, \$101F

Refer to **9.2.3 Timer Input Capture 4/Output Compare 5 Register**.

9.3.2 Timer Compare Force Register

The CFORC register allows forced early compares. FOC[1:5] correspond to the five output compares. These bits are set for each output compare that is to be forced. The action taken as a result of a forced compare is the same as if there were a match between the OCx register and the free-running counter, except that the corresponding interrupt status flag bits are not set. The forced channels trigger their programmed pin actions to occur at the next timer count transition after the write to CFORC.

The CFORC bits should not be used on an output compare function that is programmed to toggle its output on a successful compare because a normal compare that occurs immediately before or after the force can result in an undesirable operation.

CFORC — Timer Compare Force

\$100B

Bit 7	6	5	4	3	2	1	Bit 0
FOC1	FOC2	FOC3	FOC4	FOC5	0	0	0

RESET: 0 0 0 0 0 0 0 0

FOC1–FOC5 — Write Ones to Force Compare(s)

0 = Not affected

1 = Output x action occurs

Bits [2:0] — Not implemented

Always read zero

9.3.3 Output Compare Mask Registers

Use OC1M with OC1 to specify the bits of port A that are affected by a successful OC1 compare. The bits of the OC1M register correspond to PA7–PA3.

OC1M — Output Compare 1 Mask

\$100C

Bit 7	6	5	4	3	2	1	Bit 0
OC1M7	OC1M6	OC1M5	OC1M4	OC1M3	0	0	0

RESET: 0 0 0 0 0 0 0 0

OC1M7–OC1M3 — Output Compare Masks

0 = OC1 is disabled

1 = OC1 is enabled to control the corresponding pin of port A

Bits [2:0] — Not implemented

These bits always read zero. Set bit(s) to enable OC1 to control corresponding pin(s) of port A.

9.3.4 Output Compare Data Register

Use this register with OC1 to specify the data that is to be stored on the affected pin of port A after a successful OC1 compare. When a successful OC1 compare occurs, a data bit in OC1D is stored in the corresponding bit of port A for each bit that is set in OC1M.

OC1D — Output Compare 1 Data

\$100D

	Bit 7	6	5	4	3	2	1	Bit 0
	OC1D7	OC1D6	OC1D5	OC1D4	OC1D3	0	0	0
RESET:	0	0	0	0	0	0	0	0

If OC1M_x is set, data in OC1D_x is output to port A bit x on successful OC1 compares.

Bits [2:0] — Not implemented
Always read zero

9.3.5 Timer Counter Register

The 16-bit read-only TCNT register contains the prescaled value of the 16-bit timer. A full counter read addresses the most significant byte (MSB) first. A read of this address causes the least significant byte (LSB) to be latched into a buffer for the next CPU cycle so that a double-byte read returns the full 16-bit state of the counter at the time of the MSB read cycle.

TCNT — Timer Counter

\$100E, \$100F

\$100E	Bit 15	14	13	12	11	10	9	Bit 8	TCNT (High)
\$100F	Bit 7	6	5	4	3	2	1	Bit 0	TCNT (Low)

TCNT resets to \$0000.

In normal modes, TCNT is read-only.

9.3.6 Timer Control 1 Register

The bits of this register specify the action taken as a result of a successful OC_x compare.

TCTL1 — Timer Control 1

\$1020

	Bit 7	6	5	4	3	2	1	Bit 0
	OM2	OL2	OM3	OL3	OM4	OL4	OM5	OL5
RESET:	0	0	0	0	0	0	0	0

OM[2:5] — Output Mode

OL[2:5] — Output Level

These control bit pairs are encoded to specify the action taken after a successful OCx compare. OC5 functions only if the I4/O5 bit in the PACTL register is clear. Refer to the following table for the coding.

OMx	OLx	Action Taken on Successful Compare
0	0	Timer disconnected from output pin logic
0	1	Toggle OCx output line
1	0	Clear OCx output line to 0
1	1	Set OCx output line to 1

9.3.7 Timer Interrupt Mask 1 Register

Use this 8-bit register to enable or inhibit the timer input capture and output compare interrupts. Bits in TMSK1 correspond bit for bit with flag bits in TFLG1. Ones in TMSK1 enable the corresponding interrupt sources.

TMSK1 — Timer Interrupt Mask 1

\$1022

Bit 7	6	5	4	3	2	1	Bit 0
OC1I	OC2I	OC3I	OC4I	I4/O5I	IC1I	IC2I	IC3I
RESET:	0	0	0	0	0	0	0

OC1I–OC4I — Output Compare x Interrupt Enable

If the OCxI enable bit is set when the OCxF flag bit is set, a hardware interrupt sequence is requested.

I4/O5I — Input Capture 4/Output Compare 5 Interrupt Enable

When I4/O5 in PACTL is one, I4/O5I is the input capture 4 interrupt enable bit. When I4/O5 in PACTL is zero, I4/O5I is the output compare 5 interrupt enable bit.

IC1I–IC3I — Input Capture x Interrupt Enable

If the ICxI enable bit is set when the ICxF flag bit is set, a hardware interrupt sequence is requested.

9.3.8 Timer Interrupt Flag 1 Register

Bits in this register indicate when timer system events have occurred. Coupled with the bits of TMSK1, the bits of TFLG1 allow the timer subsystem to operate in either a polled or interrupt driven system. Each bit of TFLG1 corresponds to a bit in TMSK1 in the same position.

TFLG1 — Timer Interrupt Flag 1

\$1023

Bit 7	6	5	4	3	2	1	Bit 0
OC1F	OC2F	OC3F	OC4F	I4/O5F	IC1F	IC2F	IC3F
RESET:	0	0	0	0	0	0	0

Clear flags by writing a one to the corresponding bit position(s).

OC1F–OC5F — Output Compare x Flag

These bits are set each time the counter matches the output compare x value.

I4/O5F — Input Capture 4/Output Compare 5 Flag

This bit is set by IC4 or OC5, depending on the function enabled by the I4/O5 bit in PACTL.

IC1F–IC3F — Input Capture x Flag

These bits are set each time a selected active edge is detected on the ICx input line.

9.3.9 Timer Interrupt Mask 2 Register

Use this 8-bit register to enable or inhibit timer overflow and real-time interrupts. The timer prescaler control bits are included in this register.

TMSK2 — Timer Interrupt Mask 2

\$1024

Bit 7	6	5	4	3	2	1	Bit 0
TOI	RTII	PAOVI	PAII	0	0	PR1	PR0
RESET:	0	0	0	0	0	0	0

TOI — Timer Overflow Interrupt Enable

0 = TOF interrupts disabled

1 = Interrupt requested when TOF is set to one

RTII — Real-time Interrupt Enable

Refer to **9.4 Real-Time Interrupt**.

PAOVI — Pulse Accumulator Overflow Interrupt Enable

Refer to **9.6 Pulse Accumulator**.

PAII — Pulse Accumulator Input Edge Interrupt Enable

Refer to **9.6 Pulse Accumulator**.

NOTE

Bits in TMSK2 correspond bit for bit with flag bits in TFLG2. Ones in TMSK2 enable the corresponding interrupt sources.

PR[1:0] — Timer Prescaler Select

These bits are used to select the prescaler divide-by ratio. In normal modes, PR[1:0] can only be written once, and the write must be within 64 cycles after reset. Refer to Table 9–1 for specific timing values.

PR[1:0]	Prescaler
00	1
01	4
10	8
11	16

9.3.10 Timer Interrupt Flag 2 Register

Bits in this register indicate when certain timer system events have occurred. Coupled with the four high-order bits of TMSK2, the bits of TFLG2 allow the timer subsystem to operate in either a polled or interrupt driven system. Each bit of TFLG2 corresponds to a bit in TMSK2 in the same position.

TFLG2 — Timer Interrupt Flag 2

\$1025

Bit 7	6	5	4	3	2	1	Bit 0
TOF	RTIF	PAOVF	PAIF	0	0	0	0
RESET:	0	0	0	0	0	0	0

Clear flags by writing a one to the corresponding bit position(s).

TOF — Timer Overflow Interrupt Flag

TOF is set when TCNT changes from \$FFFF to \$0000.

RTIF — Real-Time (Periodic) Interrupt Flag

Refer to **9.4 Real-Time Interrupt**.

PAOVF — Pulse Accumulator Overflow Interrupt Flag

Refer to **9.6 Pulse Accumulator**.

PAIF — Pulse Accumulator Input Edge Interrupt Flag

Refer to **9.6 Pulse Accumulator**.

Bits [3:0] — Not implemented

Always read zero

9.4 Real-Time Interrupt

The real-time interrupt (RTI) feature, used to generate hardware interrupts at a fixed periodic rate, is controlled and configured by two bits (RTR1 and RTR0) in the pulse accumulator control (PACTL) register. The RTII bit in the TMSK2 register enables the interrupt capability. The four different rates available are a product of the MCU oscillator frequency and the value of bits RTR[1:0]. Refer to the following table, which shows the periodic real-time interrupt rates.

RTR[1:0]	E = 1 MHz	E = 2 MHz	E = 3 ms	E = X MHz
0 0	2.731 ms	4.096 ms	8.192 ms	$(E/2^{13})$
0 1	5.461 ms	8.192 ms	16.384 ms	$(E/2^{14})$
1 0	10.923 ms	16.384 ms	32.768 ms	$(E/2^{15})$
1 1	21.845 ms	32.768 ms	65.536 ms	$(E/2^{16})$

The clock source for the RTI function is a free-running clock that cannot be stopped or interrupted except by reset. This clock causes the time between successive RTI timeouts to be a constant that is independent of the software latencies associated with flag clearing and service. For this reason, an RTI period starts from the previous timeout, not from when RTIF is cleared.

Every timeout causes the RTIF bit in TFLG2 to be set, and if RTII is set, an interrupt request is generated. After reset, one entire RTI period elapses before the RTIF flag is set for the first time. Refer to the TMSK2, TFLG2, and PACTL registers.

9.4.1 Timer Interrupt Mask 2 Register

This register contains the real-time interrupt enable bits.

TMSK2 — Timer Interrupt Mask 2

\$1024

	Bit 7	6	5	4	3	2	1	Bit 0
	TOI	RTII	PAOVI	PAII	0	0	PR1	PR0
RESET:	0	0	0	0	0	0	0	0

TOI — Timer Overflow Interrupt Enable

0 = TOF interrupts disabled

1 = Interrupt requested when TOF is set to one

RTII — Real-time Interrupt Enable

0 = RTIF interrupts disabled

1 = Interrupt requested when RTIF is set to one

PAOVI — Pulse Accumulator Overflow Interrupt Enable

Refer to **9.6 Pulse Accumulator**.

PAII — Pulse Accumulator Input Edge Interrupt Enable
Refer to **9.6 Pulse Accumulator**.

NOTE

Bits in TMSK2 correspond bit for bit with flag bits in TFLG2. Ones in TMSK2 enable the corresponding interrupt sources.

9.4.2 Timer Interrupt Flag 2 Register

Bits of this register indicate the occurrence of timer system events. Coupled with the four high-order bits of TMSK2, the bits of TFLG2 allow the timer subsystem to operate in either a polled or interrupt driven system. Each bit of TFLG2 corresponds to a bit in TMSK2 in the same position.

TFLG2 — Timer Interrupt Flag 2

\$1025

	Bit 7	6	5	4	3	2	1	Bit 0
	TOF	RTIF	PAOVF	PAIF	0	0	0	0
RESET:	0	0	0	0	0	0	0	0

Clear flags by writing a one to the corresponding bit position(s).

TOF — Timer Overflow Interrupt Flag

TOF is set when TCNT changes from \$FFFF to \$0000.

RTIF — Real-Time Interrupt Flag

The RTIF status bit is automatically set to one at the end of every RTI period. To clear RTIF, write a byte to TFLG2 with bit 6 set.

PAOVF — Pulse Accumulator Overflow Interrupt Flag

Refer to **9.6 Pulse Accumulator**.

PAIF — Pulse Accumulator Input Edge Interrupt Flag

Refer to **9.6 Pulse Accumulator**.

Bits [3:0] — Not implemented

Always read zero

9.4.3 Pulse Accumulator Control Register

Bits RTR[1:0] of this register select the rate for the RTI system. Bit DDRA3 determines whether Port A bit three is an input or an output when used for general-purpose I/O. The remaining bits control the pulse accumulator.

PACTL — Pulse Accumulator Control

\$1026

	Bit 7	6	5	4	3	2	1	Bit 0
	DDRA7	PAEN	PAMOD	PEDGE	DDRA3	I4/O5	RTR1	RTR0
RESET:	0	0	0	0	0	0	0	0

DDRA7 — Data Direction Control for Port A Bit 7

Refer to **9.6 Pulse Accumulator**.

PAEN — Pulse Accumulator System Enable

PAMOD — Pulse Accumulator Mode

PEDGE — Pulse Accumulator Edge Control

DDRA3 — Data Direction Register for Port A Bit 3

Refer to **SECTION 6 PARALLEL INPUT/OUTPUT**.

I4/O5 — Input Capture 4/Output Compare 5

Refer to **9.6 Pulse Accumulator**.

RTR[1:0] — RTI Interrupt Rate Select

These two bits determine the rate at which the RTI system requests interrupts. The RTI system is driven by an E divided by 2^{13} rate clock that is compensated so it is independent of the timer prescaler. These two control bits select an additional division factor.

9.5 Computer Operating Properly Watchdog Function

The clocking chain for the computer operating properly (COP) function, tapped off of the main timer divider chain, is only superficially related to the main timer system. The CR[1:0] bits in the OPTION register and the NOCOP bit in the CONFIG register determine the status of the COP function. These bits are discussed in the following paragraphs. Refer to **SECTION 5 RESETS AND INTERRUPTS** for a more detailed discussion of the COP function.

9.5.1 Option Register

OPTION — System Configuration Options

\$1039

	Bit 7	6	5	4	3	2	1	Bit 0
	ADPU	CSEL	IRQE*	DLY*	CME	0	CR1*	CR0*
RESET:	0	0	0	1	0	0	0	0

*Can be written only once in first 64 cycles out of reset in normal modes, or at any time in special modes.

ADPU — A/D Power-Up

Refer to **SECTION 5 RESETS AND INTERRUPTS.**

CSEL — Clock Select

Refer to **SECTION 5 RESETS AND INTERRUPTS.**

IRQE — Configure $\overline{\text{IRQ}}$ for Edge Sensitive Only Operation

Refer to **SECTION 5 RESETS AND INTERRUPTS.**

DLY — Enable Oscillator Startup Delay

Refer to **SECTION 5 RESETS AND INTERRUPTS.**

CME — Clock Monitor Enable

Refer to **SECTION 5 RESETS AND INTERRUPTS.**

Bit 2 — Not implemented

This bit always reads zero.

CR[1:0] — COP Timer Rate Select Bits

The MCU internal E clock is first divided by 2^{15} before it enters the COP system. The CR1 and CR0 control bits control additional scaling for the watchdog timer. After reset, the timeout period is configured for the shortest duration by default. In normal operating modes, these bits can only be written once, and that write must take place within the first 64 bus cycles after reset. Refer to **SECTION 5 RESETS AND INTERRUPTS** for further information.

9.5.2 CONFIG Register

The system configuration register controls the presence of EPROM and EEPROM in the memory map. It also enables the COP watchdog system.

CONFIG — Configuration Control Register

\$103F

	Bit 7	6	5	4	3	2	1	Bit 0
	0	0	0	0	NOSEC	NOCOP	EPON	EEON
RESET:	0	0	0	0	1	—	—	—

NOSEC — EEPROM Security Disable

Refer to **SECTION 4 OPERATING MODES AND ON-CHIP MEMORY.**

NOCOP — COP System Disable

This bit is cleared out of reset in normal modes, enabling the COP system. It is writable only once after reset in these modes (SMOD = 0). In test and bootstrap modes, NOCOP comes out of reset equal to one, and is writable at any time.

0 = The COP system is enabled as the MCU comes out of reset.

1 = The COP system is disabled and does not generate system resets.

EPON — Enable On-Chip PROM

Refer to **SECTION 4 OPERATING MODES AND ON-CHIP MEMORY.**

EEON — Enable On-Chip EEPROM

Refer to **SECTION 4 OPERATING MODES AND ON-CHIP MEMORY.**

9.6 Pulse Accumulator

The MC68HC711L6 has an 8-bit counter that can be configured to operate either as a simple event counter, or for gated time accumulation, depending on the state of the PAMOD bit in the PACTL register. Refer to the pulse accumulator block diagram, Figure 9-3.

In the event counting mode, the 8-bit counter is clocked to increasing values by an external pin. The maximum clocking rate for the external event counting mode is the E clock divided by two. In gated time accumulation mode, a free-running E-clock \div 64 signal drives the 8-bit counter, but only while the external PAI pin is activated. Refer to Table 9-3. The pulse accumulator counter can be read or written at any time.

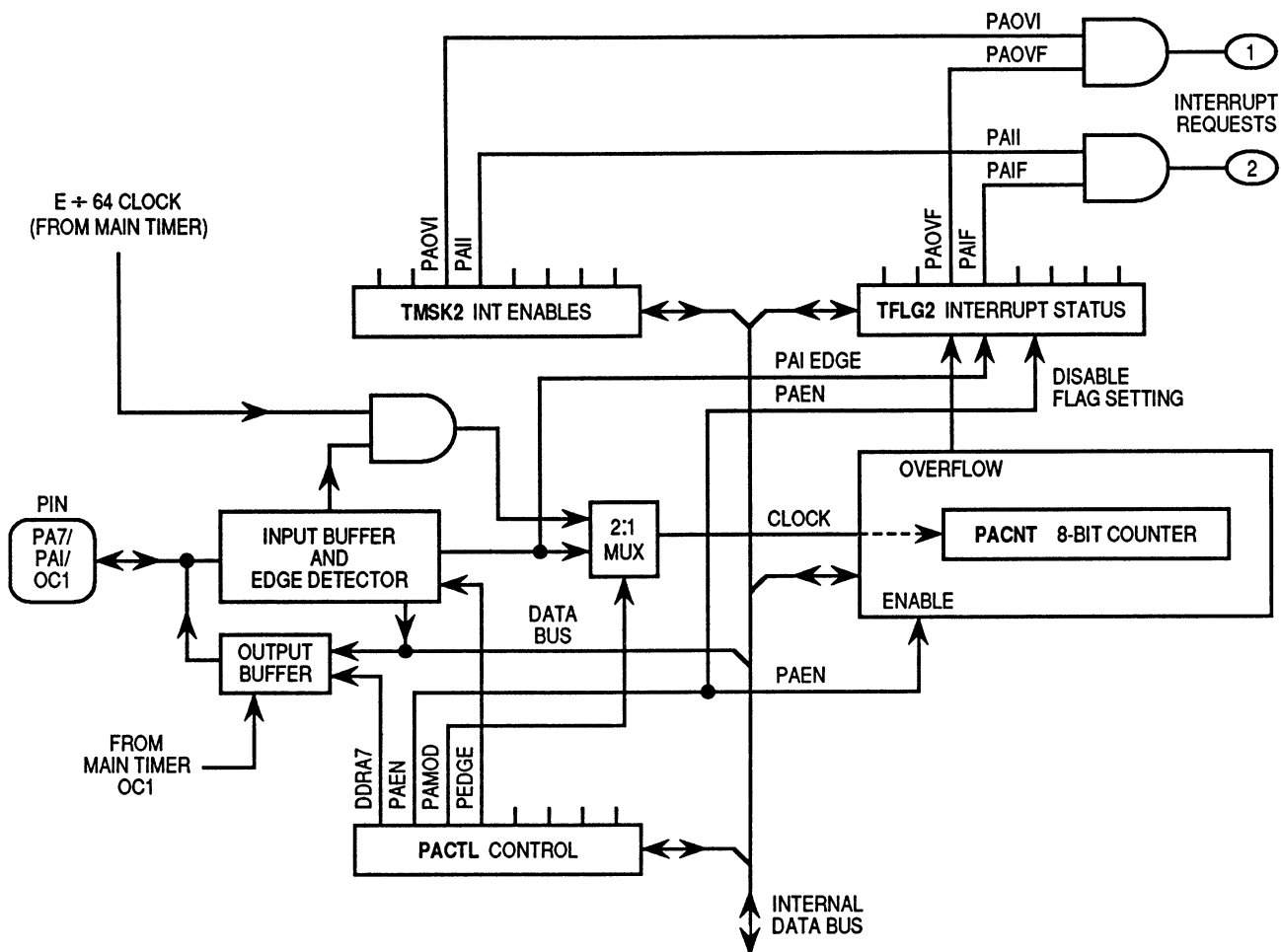

Figure 9-3. Pulse Accumulator

Table 9–3. Pulse Accumulator Timing

Crystal Frequency	E Clock	Cycle Time	E + 64	PACNT Overflow
4.0 MHz	1.0 MHz	1000 ns	64 μ s	16.384 ms
8.0 MHz	2.0 MHz	500 ns	32 μ s	8.192 ms
12.0 MHz	3.0 MHz	333 ns	21.33 μ s	5.461 ms

Pulse accumulator control bits are also located within two timer registers, TMSK2 and TFLG2, as described in the following paragraphs.

9.6.1 Pulse Accumulator Control Register

Four of this register's bits control an 8-bit pulse accumulator system. Another bit enables either the OC5 function or the IC4 function, while two other bits select the rate for the real-time interrupt system.

PACTL — Pulse Accumulator Control

\$1026

	Bit 7	6	5	4	3	2	1	Bit 0
	DDRA7	PAEN	PAMOD	PEDGE	DDRA3	I4/O5	RTR1	RTR0
RESET:	0	0	0	0	0	0	0	0

DDRA7 — Data Direction Control for Port A Bit 7

The pulse accumulator uses port A bit 7 as the PAI input, but the pin can also be used as general-purpose I/O or as an output compare. Note that even when port A bit 7 is configured as an output, the pin still drives the input to the pulse accumulator. Refer to **SECTION 6 PARALLEL INPUT/OUTPUT** for more information.

PAEN — Pulse Accumulator System Enable

- 0 = Pulse Accumulator disabled
- 1 = Pulse Accumulator enabled

PAMOD — Pulse Accumulator Mode

- 0 = Event counter
- 1 = Gated time accumulation

PEDGE — Pulse Accumulator Edge Control

This bit has different meanings depending on the state of the PAMOD bit, as shown in the following table.

PAMOD	PEDGE	Action on Clock
0	0	PAI Falling Edge Increments the Counter.
0	1	PAI Rising Edge Increments the Counter.
1	0	A Zero on PAI Inhibits Counting.
1	1	A One on PAI Inhibits Counting.

DDRA3 — Data Direction Register for Port A Bit 3

0 = Input only

1 = Output

I4/O5 — Input Capture 4/Output Compare 5

0 = Output compare 5 function enabled (No IC4)

1 = Input capture 4 function enabled (No OC5)

RTR[1:0] — RTI Interrupt Rate Selects

Refer to **9.4 Real-Time Interrupt**.

9.6.2 Pulse Accumulator Count Register

This 8-bit read/write register contains the count of external input events at the PAI input, or the accumulated count. The PACNT is readable even if PAI is not active in gated time accumulation mode. The counter is not affected by reset and can be read or written at any time. Counting is synchronized to the internal PH2 clock so that incrementing and reading occur during opposite half cycles.

PACNT — Pulse Accumulator Count

\$1027

Bit 7	6	5	4	3	2	1	Bit 0
Bit 7	6	5	4	3	2	1	Bit 0

9.6.3 Pulse Accumulator Status and Interrupt Bits

The pulse accumulator control bits, PAOVI, PAII, PAOVF, and PAIF are located within timer registers TMSK2 and TFLG2.

PAOVI and PAOVF — Pulse Accumulator Interrupt Enable and Overflow Flag

The PAOVF status bit is set each time the pulse accumulator count rolls over from \$FF to \$00. To clear this status bit, write a one in the corresponding data bit position (bit 5) of the TFLG2 register. The PAOVI control bit allows configuring the pulse accumulator overflow for polled or interrupt-driven operation and does not affect the state of PAOVF. When PAOVI is zero, pulse accumulator overflow interrupts are inhibited, and the system operates in a polled mode, which requires that PAOVF be polled by user software to determine when an overflow has occurred. When the PAOVI control bit is set, a hardware interrupt request is generated each time PAOVF is set. Before leaving the interrupt service routine, software must clear PAOVF by writing to the TFLG2 register.

PAII and PAIF — Pulse Accumulator Input Edge Interrupt Enable and Flag

The PAIF status bit is automatically set each time a selected edge is detected at the PA7/PAI/OC1 pin. To clear this status bit, write to the TFLG2 register with a one in

the corresponding data bit position (bit 4). The PAII control bit allows configuring the pulse accumulator input edge detect for polled or interrupt-driven operation but does not affect setting or clearing the PAIF bit. When PAII is zero, pulse accumulator input interrupts are inhibited, and the system operates in a polled mode. In this mode, the PAIF bit must be polled by user software to determine when an edge has occurred. When the PAII control bit is set, a hardware interrupt request is generated each time PAIF is set. Before leaving the interrupt service routine, software must clear PAIF by writing to the TFLG2 register.

TMSK2 — Timer Interrupt Mask 2 Register

\$1024

	Bit 7	6	5	4	3	2	1	Bit 0
	TOI	RTII	PAOVI	PAII	0	0	PR1	PR0
RESET:	0	0	0	0	0	0	0	0

TFLG2 — Timer Interrupt Flag 2 Register

\$1025

	Bit 7	6	5	4	3	2	1	Bit 0
	TOF	RTIF	PAOVF	PAIF	0	0	0	0
RESET:	0	0	0	0	0	0	0	0

SECTION 10 ANALOG-TO-DIGITAL CONVERTER

The analog-to-digital (A/D) system, a successive approximation converter, uses an all-capacitive charge redistribution technique to convert analog signals to digital values.

10.1 Overview

The A/D system is an 8-channel, 8-bit, multiplexed-input converter, accurate to ± 1 least significant bit (LSB). It does not require external sample and hold circuits because of the type of charge redistribution technique used. A/D converter timing can be synchronized to the system E clock, or to an internal resistor capacitor (RC) oscillator. The A/D converter system consists of four functional blocks: multiplexer, analog converter, digital control, and result storage. Refer to Figure 10–1.

10.1.1 Multiplexer

The multiplexer selects one of 16 inputs for conversion. Input selection is controlled by the value of bits CD – CA in the ADCTL register. The eight port E pins are fixed-direction analog inputs to the multiplexer, and additional internal analog signal lines are routed to it.

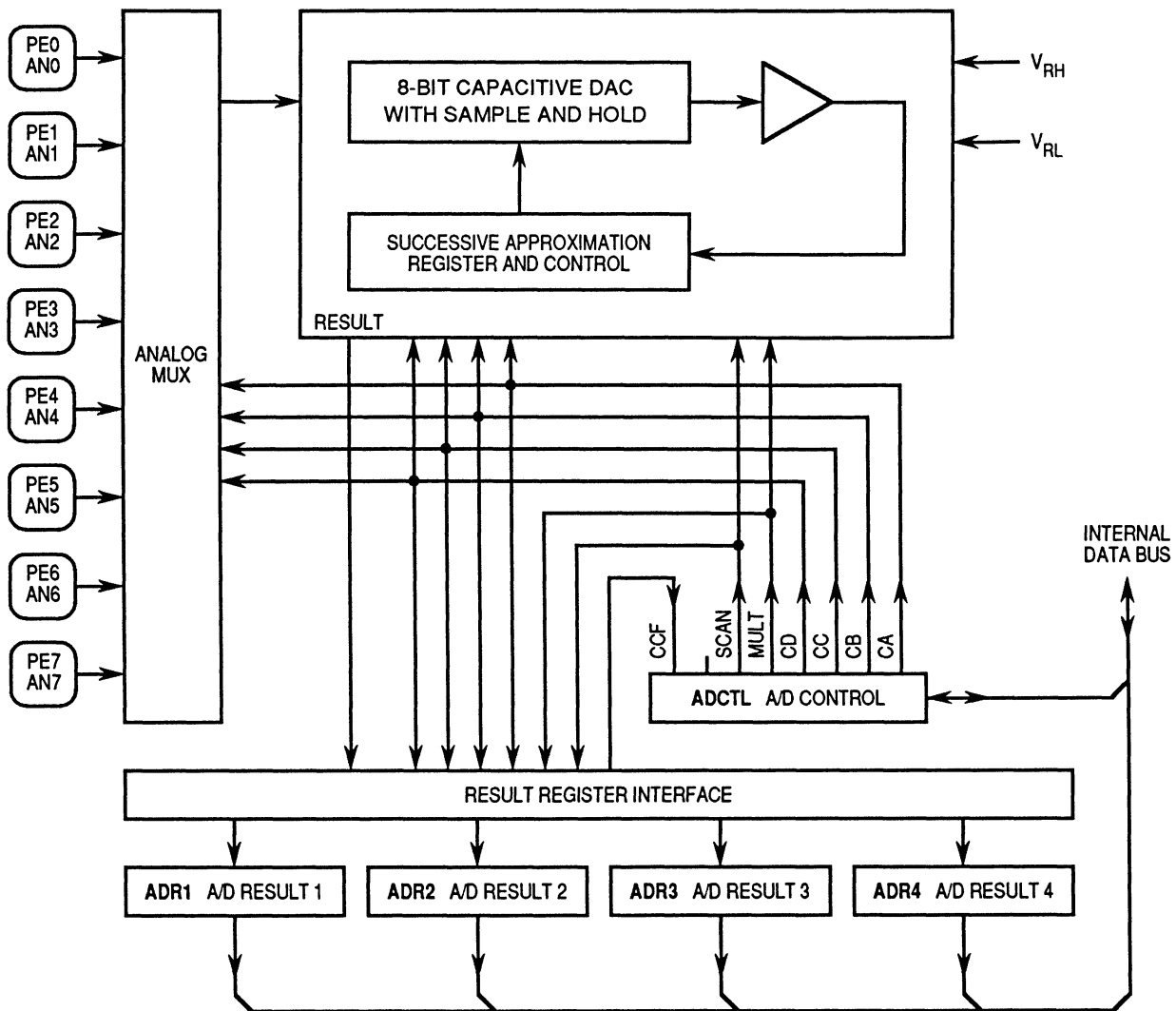
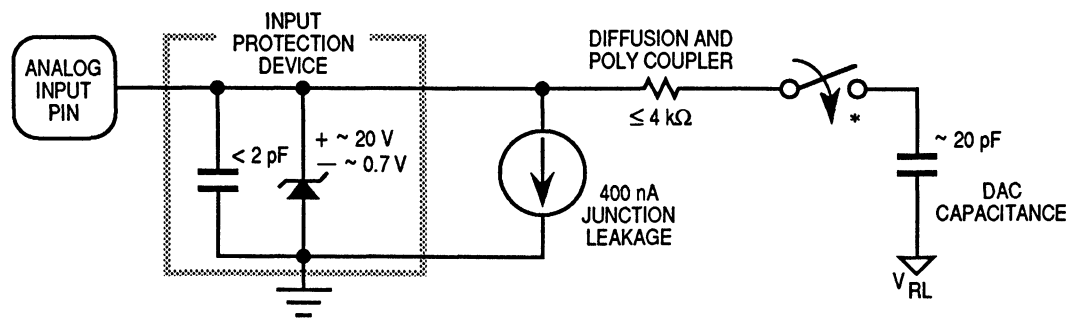

Figure 10–1. A/D Converter Block Diagram

Port E pins can also be used as digital inputs. Digital reads of port E pins are not recommended during the sample portion of an A/D conversion cycle, when the gate signal to the N-channel input gate is on. Because no P-channel devices are directly connected to either input pins or reference voltage pins, voltages above V_{DD} do not cause a latchup problem, although current should be limited according to maximum ratings. Refer to Figure 10–2, which is a functional diagram of an input pin.



*This analog switch is closed only during the 12-cycle sample time.

Figure 10–2. Electrical Model of an A/D Input Pin (Sample Mode)

10.1.2 Analog Converter

Conversion of an analog input selected by the multiplexer occurs in this block. It contains a digital-to-analog capacitor (DAC) array, a comparator, and a successive approximation register. Each conversion is a sequence of eight comparison operations, beginning with the most significant bit (MSB). Each comparison determines the value of a bit in the successive approximation register (SAR).

The DAC capacitor array performs two functions. It acts as a sample and hold circuit during the entire conversion sequence, and provides comparison voltage to the comparator during each successive comparison.

The result of each successive comparison is stored in the SAR. When a conversion sequence is complete, the contents of the SAR are transferred to the appropriate result register.

A charge pump provides plate voltage to the capacitor array, and switching voltage to the gates of analog switches in the multiplexer. Charge pump output must stabilize between 7 and 8 volts before the converter can be used. The charge pump is enabled by the ADPU bit in the OPTION register.

10.1.3 Digital Control

All A/D converter operations are controlled by bits in register ADCTL. In addition to selecting the analog input to be converted, ADCTL bits indicate conversion status, and control whether single or continuous conversions are performed. Finally, the ADCTL bits determine whether conversions are performed on single or multiple channels.

10.1.4 Result Registers

Four 8-bit registers (ADR1–ADR4) store conversion results. Each of these registers can be accessed by the processor in the CPU. The conversion complete flag (CCF) indicates when valid data is present in the result registers. The result registers are written during a portion of the system clock cycle when reads do not occur, so there is no conflict.

10.1.5 A/D Converter Clocks

The CSEL bit in the OPTION register selects whether the A/D converter uses the system E clock or an internal RC oscillator for synchronization. When E-clock frequency is below 750 kHz, charge leakage in the capacitor array can cause errors, and the internal oscillator should be used. When the RC clock is used, additional errors can occur because the comparator is sensitive to the additional system clock noise.

10.1.6 Conversion Sequence

A/D converter operations are performed in sequences of four conversions each. A conversion sequence can repeat continuously or stop after one iteration. The conversion complete flag (CCF) is set after the fourth conversion in a sequence to show the availability of data in the result registers. Figure 10–3 shows the timing of a typical sequence. Synchronization is referenced to the system E clock.

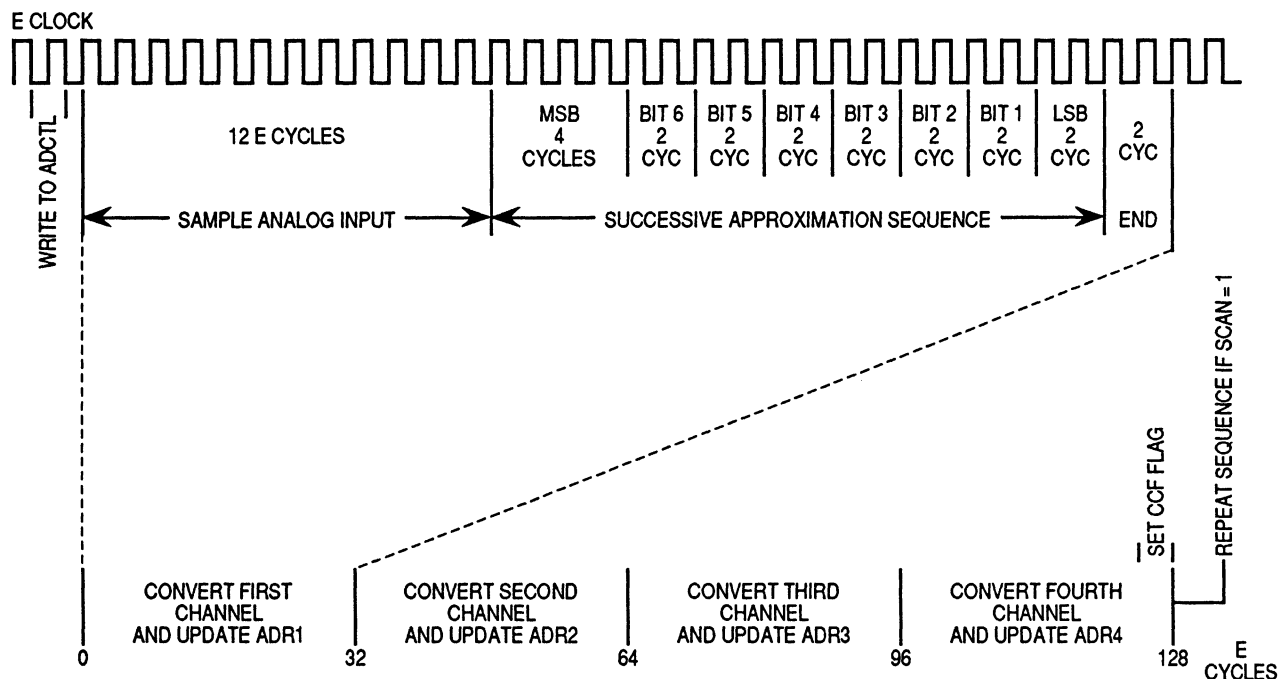

Figure 10–3. A/D Conversion Sequence

10.2 A/D Converter Power-Up and Clock Select

Bit 7 of the OPTION register controls A/D converter power up. Clearing ADPU removes power from and disables the A/D converter system. Setting ADPU enables the A/D converter system. Stabilization of the analog bias voltages requires a delay of as much as 100 microseconds after turning on the A/D converter. When the A/D converter system is operating with the MCU E clock, all switching and comparator operations are synchronized to the MCU clocks. This allows the comparator results to be sampled at quiet times, which minimizes noise errors. The internal RC oscillator is asynchronous to the MCU clock, so noise affects A/D converter results, which lowers accuracy slightly, while CSEL = 1.

OPTION — System Configuration Options

\$1039

Bit 7	6	5	4	3	2	1	Bit 0
ADPU	CSEL	IRQE*	DLY*	CME	0	CR1*	CR0*

RESET: 0 0 0 1 0 0 0 0

*Can be written only once in first 64 cycles out of reset in normal modes, or at any time in special modes

ADPU — A/D Power Up

0 = A/D powered down

1 = A/D powered up

CSEL — Clock Select

0 = A/D and EEPROM use system E clock

1 = A/D and EEPROM use internal RC clock

IRQE — Configure $\overline{\text{IRQ}}$ for Edge-Sensitive Only Operation

Refer to **SECTION 4 OPERATING MODES AND ON-CHIP MEMORY.**

DLY — Enable Oscillator Startup Delay

Refer to **SECTION 4 OPERATING MODES AND ON-CHIP MEMORY.**

CME — Clock Monitor Enable

Refer to **SECTION 5 RESETS AND INTERRUPTS.**

Bit 2 — Not implemented

Always read zero

CR[1:0] — COP Timer Rate Select Bits

Refer to **SECTION 5 RESETS AND INTERRUPTS** and **SECTION 9 TIMING SYSTEM.**

10.3 Conversion Process

The A/D conversion sequence begins one E-clock cycle after a write to the A/D control/status register, ADCTL. The bits in ADCTL select the channel and the mode of conversion. An input voltage equal to V_{RL} converts to \$00 and an input voltage equal to V_{RH} converts to \$FF (full scale), with no overflow indication. For ratiometric conversions of this type, the source of each analog input should use V_{RH} as the supply voltage and be referenced to V_{RL} .

10.4 Channel Assignments

The multiplexer allows the A/D converter to select one of sixteen analog signals. Eight of these channels correspond to port E input lines to the MCU, four of the channels are internal reference points or test functions, and four channels are reserved. Refer to Table 10–1.

Table 10–1. Channel Assignments

Channel Select	Channel Signal	Result in ADRx if MULT = 1
1	AN0	ADR1
2	AN1	ADR2
3	AN2	ADR3
4	AN3	ADR4
5	AN4	ADR1
6	AN5	ADR2
7	AN6	ADR3
8	AN7	ADR4
9–12	Reserved	—
13	V_{RH}^*	ADR1
14	V_{RL}^*	ADR2
15	$(V_{RH})/2^*$	ADR3
16	Reserved*	ADR4

*Used for factory testing

10.5 Single-Channel Operation

There are two types of single-channel operation. When $SCAN = 0$, the first type, the single selected channel is converted four consecutive times. The first result is stored in A/D result register 1 (ADR1), and the fourth result is stored in ADR4. After the fourth conversion is complete, all conversion activity is halted until a new conversion command is written to the ADCTL register. In the second type of single-channel operation, $SCAN = 1$, conversions continue to be performed on the selected channel with the fifth conversion being stored in register ADR1 (overwriting the first conversion result), the sixth conversion overwriting ADR2, and so on.

10.6 Multiple-Channel Operation

There are two types of multiple-channel operation. When $SCAN = 0$, the first type, a selected group of four channels is converted one time each. The first result is stored in A/D result register 1 (ADR1), and the fourth result is stored in ADR4. After the fourth conversion is complete, all conversion activity is halted until a new conversion command is written to the ADCTL register. In the second type of multiple-channel operation, $SCAN = 1$, conversions continue to be performed on the selected group of channels with the fifth conversion being stored in register ADR1 (replacing the earlier conversion result for the first channel in the group), the sixth conversion overwriting ADR2, and so on.

10.7 Operation in STOP and WAIT Modes

If a conversion sequence is in progress when either the STOP or WAIT mode is entered, the conversion of the current channel is suspended. When the MCU resumes normal operation, that channel is resampled and the conversion sequence is resumed. As the MCU exits the WAIT mode, the A/D circuits are stable and valid results can be obtained on the first conversion. However, in STOP mode, all analog bias currents are disabled and it is necessary to allow a stabilization period when leaving the STOP mode. If the STOP mode is exited with a delay, $DLY = 1$, there is enough time for these circuits to stabilize before the first conversion. If the STOP mode is exited with no delay (DLY bit in OPTION register = 0), allow enough time for the A/D circuitry to stabilize to avoid invalid results.

10.8 A/D Control/Status Registers

All bits in this register can be read or written, except bit 7, which is a read-only status indicator, and bit 6, which always reads as zero. Write to ADCTL to initiate a conversion. To quit a conversion in progress, write to this register and a new conversion sequence begins immediately.

ADCTL — A/D Control/Status

\$1030

	Bit 7	6	5	4	3	2	1	Bit 0
	CCF	0	SCAN	MULT	CD	CC	CB	CA
RESET:	0	0	U	U	U	U	U	U

CCF — Conversions Complete Flag

A read-only status indicator, this bit is set when all four A/D result registers contain valid conversion results. Each time the ADCTL register is overwritten, this bit is automatically cleared to zero and a conversion sequence is started. In the continuous mode, CCF is set at the end of the first conversion sequence.

Bit 6 — Not implemented
Always reads zero

SCAN — Continuous Scan Control

When this control bit is clear, the four requested conversions are performed once to fill the four result registers. When this control bit is set, conversions continue in a round-robin fashion with the result registers updated as data becomes available.

MULT — Multiple-Channel/Single-Channel Control

When this bit is clear, the A/D converter system is configured to perform four consecutive conversions on the single channel specified by the four channel select bits CD–CA (bits 3–0 of the ADCTL register). When this bit is set, the A/D system is configured to perform a conversion on each of four channels where each result register corresponds to one channel.

CAUTION

When the multiple-channel continuous scan mode is used, extra care is needed in the design of circuitry driving the A/D inputs. The charge on the capacitive DAC array before the sample time is related to the voltage on the previously converted channel. A charge share situation exists between the internal DAC capacitance and the external circuit capacitance. Although the amount of charge involved is small, the rate at which it is repeated is every 64 microseconds for an E clock of 2 MHz. The RC charging rate of the external circuit must be balanced against this charge sharing effect to avoid errors in accuracy.

CD-CA — Channel Selects D-A

Refer to Table 10-2. When a multiple channel mode is selected (MULT = 1), the two least significant channel select bits (CB and CA) have no meaning and the CD and CC bits specify which group of four channels is to be converted.

Table 10-2. A/D Converter Channel Selection

Channel Select Control Bits	Channel Signal	Result in ADR _x if MULT = 1
CD:CC:CB:CA		
0000	AN0	ADR1
0001	AN1	ADR2
0010	AN2	ADR3
0011	AN3	ADR4
0100	AN4	ADR1
0101	AN5	ADR2
0110	AN6	ADR3
0111	AN7	ADR4
10xx	Reserved	—
1100	V _{RH} *	ADR1
1101	V _{RL} *	ADR2
1110	(V _{RH})/2*	ADR3
1111	Reserved*	ADR4

*Used for factory testing

10.9 A/D Converter Result Registers

These read-only registers hold an 8-bit conversion result. Writes to these registers have no effect. Data in the A/D converter result registers is valid when the CCF flag in the ADCTL register is set, indicating a conversion sequence is complete. If conversion results are needed sooner, refer to the A/D conversion sequence diagram for further information.

ADR1-ADR4 — A/D Results

\$1031-\$1034

\$1031	Bit 7	6	5	4	3	2	1	Bit 0	ADR1
\$1032	Bit 7	6	5	4	3	2	1	Bit 0	ADR2
\$1033	Bit 7	6	5	4	3	2	1	Bit 0	ADR3
\$1034	Bit 7	6	5	4	3	2	1	Bit 0	ADR4

APPENDIX A ELECTRICAL CHARACTERISTICS

Table A–1. Maximum Ratings

Rating	Symbol	Value	Unit
Supply Voltage	V_{DD}	– 0.3 to + 7.0	V
Input Voltage	V_{in}	– 0.3 to + 7.0	V
Operating Temperature Range MC68HC711L6 MC68HC711L6C MC68HC711L6V MC68HC711L6M	T_A	T_L to T_H 0 to + 70 – 40 to + 85 – 40 to + 105 – 40 to + 125	°C
Storage Temperature Range	T_{stg}	– 55 to + 150	°C
Current Drain per Pin* Excluding V_{DD} , V_{SS} , V_{RH} , and V_{RL}	I_D	25	mA

*One pin at a time, observing maximum power dissipation limits.

Internal circuitry protects the inputs against damage caused by high static voltages or electric fields; however, normal precautions are necessary to avoid application of any voltage higher than maximum-rated voltages to this high-impedance circuit. Extended operation at the maximum ratings can adversely affect device reliability. Tying unused inputs to an appropriate logic voltage level (either GND or V_{DD}) enhances reliability of operation.

Table A–2. Thermal Characteristics

Characteristic	Symbol	Value	Unit
Average Junction Temperature	T_J	$T_A + (P_D \times \Theta_{JA})$	°C
Ambient Temperature	T_A	User-determined	°C
Package Thermal Resistance (Junction-to-Ambient) 68-Pin Plastic Leaded Chip Carrier 68-Pin Windowed CERQUAD (FS) 64-Pin Quad Flat Pack	Θ_{JA}	50 50 50	°C/W
Total Power Dissipation	P_D	$P_{INT} + P_{I/O}$ $K / (T_J + 273^\circ\text{C})$ (Note 1)	W
Device Internal Power Dissipation	P_{INT}	$I_{DD} \times V_{DD}$	W
I/O Pin Power Dissipation	$P_{I/O}$ (Note 2)	User-determined	W
A Constant	K	$P_D \times (T_A + 273^\circ\text{C}) + \Theta_{JA} \times P_D^2$ (Note 3)	W · °C

NOTES:

1. This is an approximate value, neglecting $P_{I/O}$.
2. For most applications $P_{I/O} \ll P_{INT}$ and can be neglected.
3. K is a constant pertaining to the device. Solve for K with a known T_A and a measured P_D (at equilibrium). Use this value of K to solve for P_D and T_J iteratively for any value of T_A .

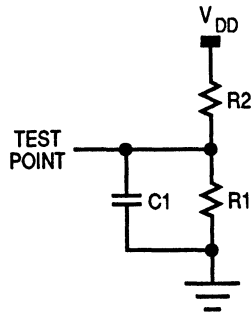

Equivalent Test Load¹

Pins	R1	R2	C1
PA3 – PA7 PB0 – PB7 PC0 – PC7 PD0, PD4 E, AS, R/W	3.26K	2.38K	90pF
PD1 – PD4	3.26K	2.38K	200pF

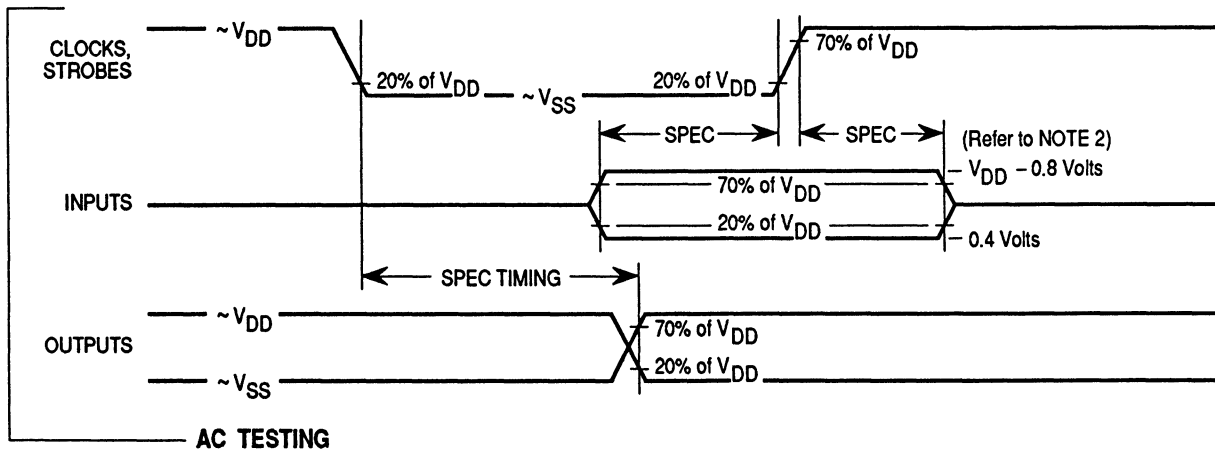
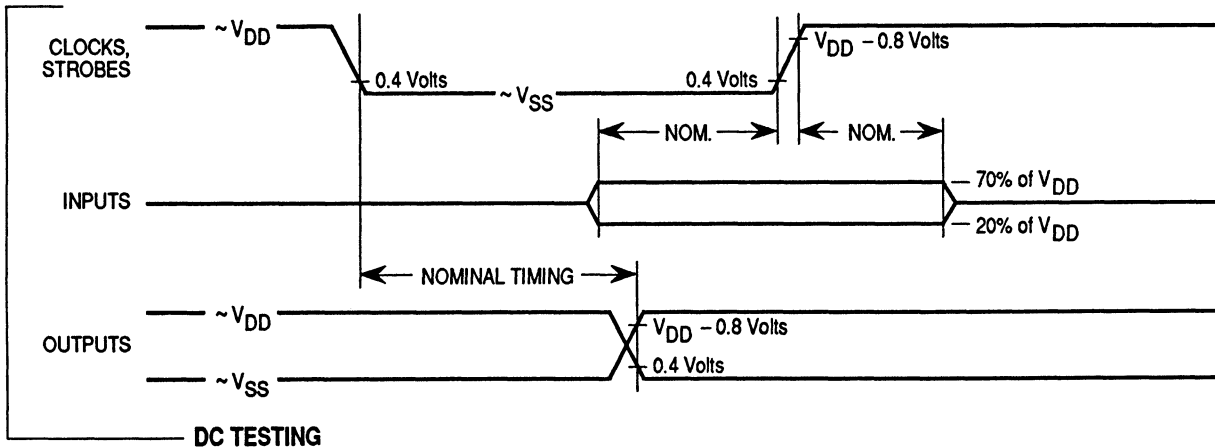

NOTES:

1. Full test loads are applied during all DC electrical tests and AC timing measurements.
2. During AC timing measurements, inputs are driven to 0.4 volts and $V_{DD} - 0.8$ volts while timing measurements are taken at the 20% and 70% of V_{DD} points.

Figure A-1. Test Methods

Table A-4. Control Timing

$V_{DD} = 5.0 \text{ Vdc} \pm 10\%$, $V_{SS} = 0 \text{ Vdc}$, $T_A = T_L \text{ to } T_H$

Characteristic	Symbol	1.0 MHz		2.0 MHz		3.0 MHz		Unit
		Min	Max	Min	Max	Min	Max	
Frequency of Operation	f_o	dc	1.0	dc	2.0	dc	3.0	MHz
E-Clock Period	t_{cyc}	1000	—	500	—	333	—	ns
Crystal Frequency	f_{XTAL}	—	4.0	—	8.0	—	12.0	MHz
External Oscillator Frequency	$4 f_o$	dc	4.0	dc	8.0	dc	12.0	MHz
Processor Control Setup Time $t_{PCSU} = 1/4 t_{cyc} + 50 \text{ ns}$	t_{PCSU}	300	—	175	—	133	—	ns
Reset Input Pulse Width (Note 1) (To Guarantee External Reset Vector) (Minimum Input Time; Can Be Preempted by Internal Reset)	PW_{RSTL}	8 1	— —	8 1	— —	8 1	— —	t_{cyc}
Mode Programming Setup Time	t_{MPS}	2	—	2	—	2	—	t_{cyc}
Mode Programming Hold Time	t_{MPH}	10	—	10	—	10	—	ns
Interrupt Pulse Width, \overline{IRQ} Edge-Sensitive Mode $PW_{IRQ} = t_{cyc} + 20 \text{ ns}$	PW_{IRQ}	1020	—	520	—	353	—	ns
Wait Recovery Startup Time	t_{WRS}	—	4	—	4	—	4	t_{cyc}
Timer Pulse Width Input Capture Pulse Accumulator Input $PW_{TIM} = t_{cyc} + 20 \text{ ns}$	PW_{TIM}	1020	—	520	—	353	—	ns

NOTES:

- RESET is recognized during the first clock cycle it is held low. Internal circuitry then drives the pin low for four clock cycles, releases the pin, and samples the pin level two cycles later to determine the source of the interrupt. Refer to **SECTION 5 RESETS AND INTERRUPTS** for further detail.
- All timing is shown with respect to 20% V_{DD} and 70% V_{DD} , unless otherwise noted.

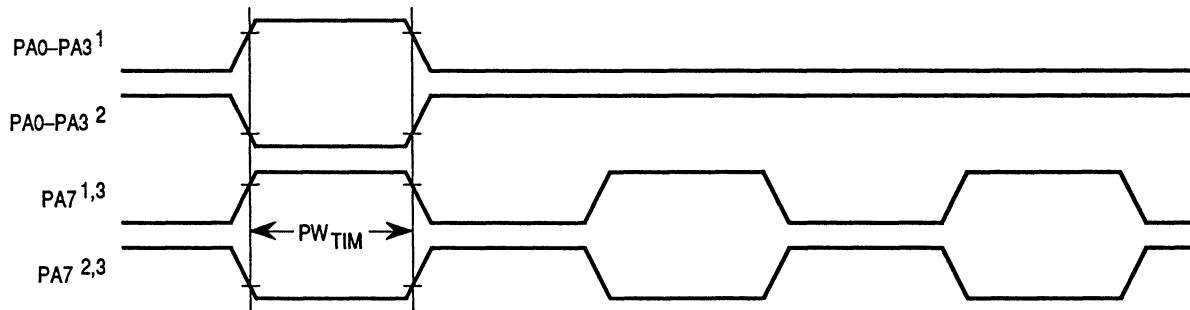

NOTES:

- Rising edge sensitive input
- Falling edge sensitive input
- Maximum pulse accumulator clocking rate is E-clock frequency divided by 2.

Figure A-2. Timer Inputs

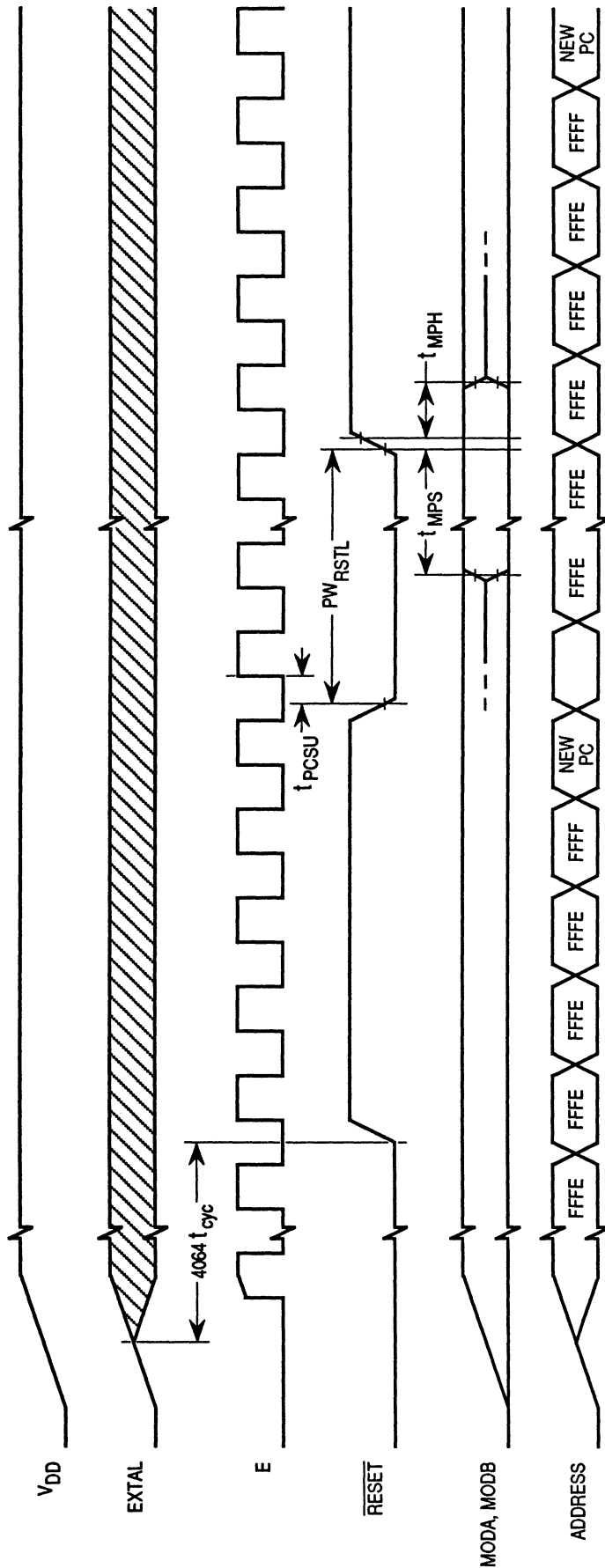
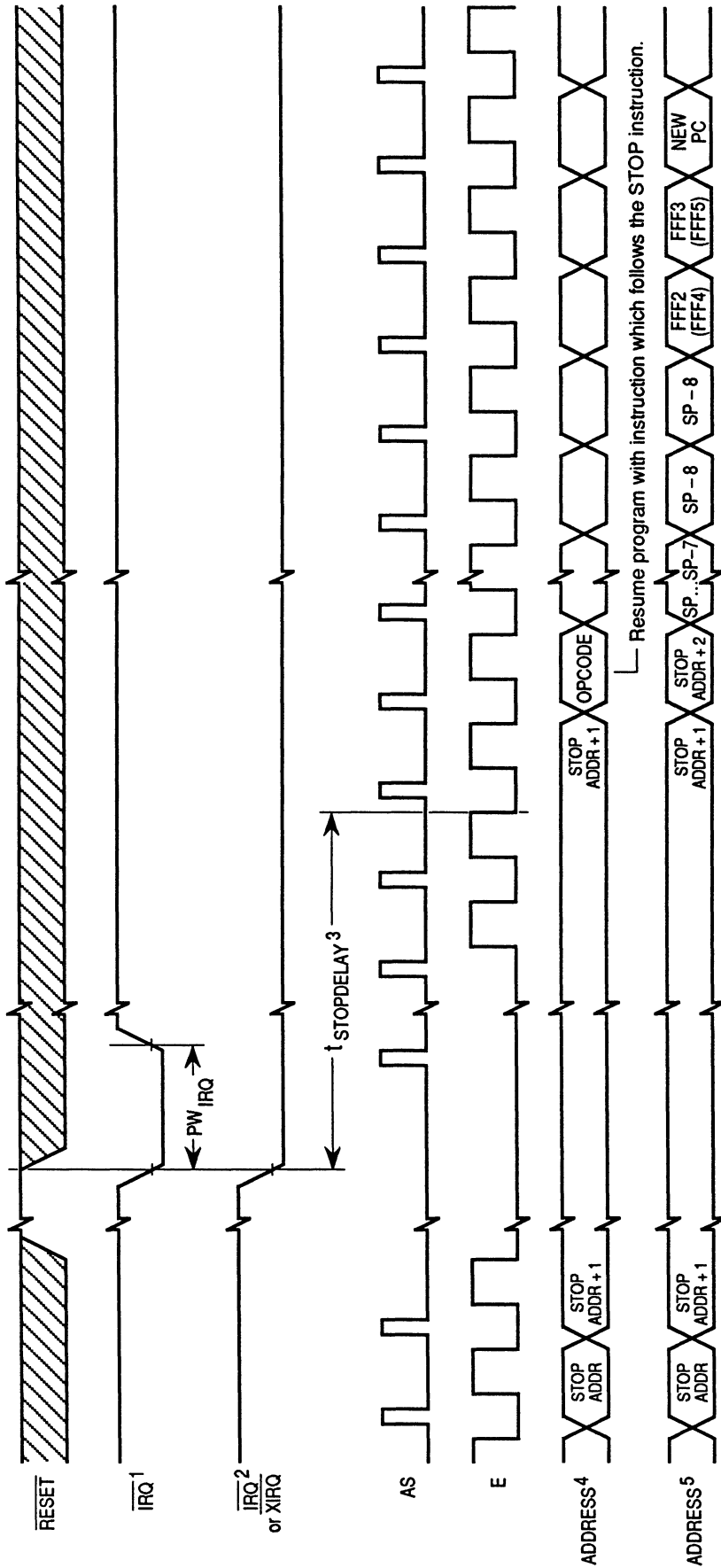

Figure A-3. POR and External Reset Timing Diagram



NOTES:

1. Edge Sensitive \overline{IRQ} pin (IRQE bit = 1)
2. Level sensitive \overline{IRQ} pin (IRQE bit = 0)
3. $t_{STOPDELAY} = 4064 t_{cyc}$ if DLY bit = 1 or 4 t_{cyc} if DLY = 0.
4. \overline{XIRQ} with X bit in CCR = 1.
5. \overline{IRQ} or \overline{XIRQ} with X bit in CCR = 0).

Figure A-4. STOP Recovery Timing Diagram

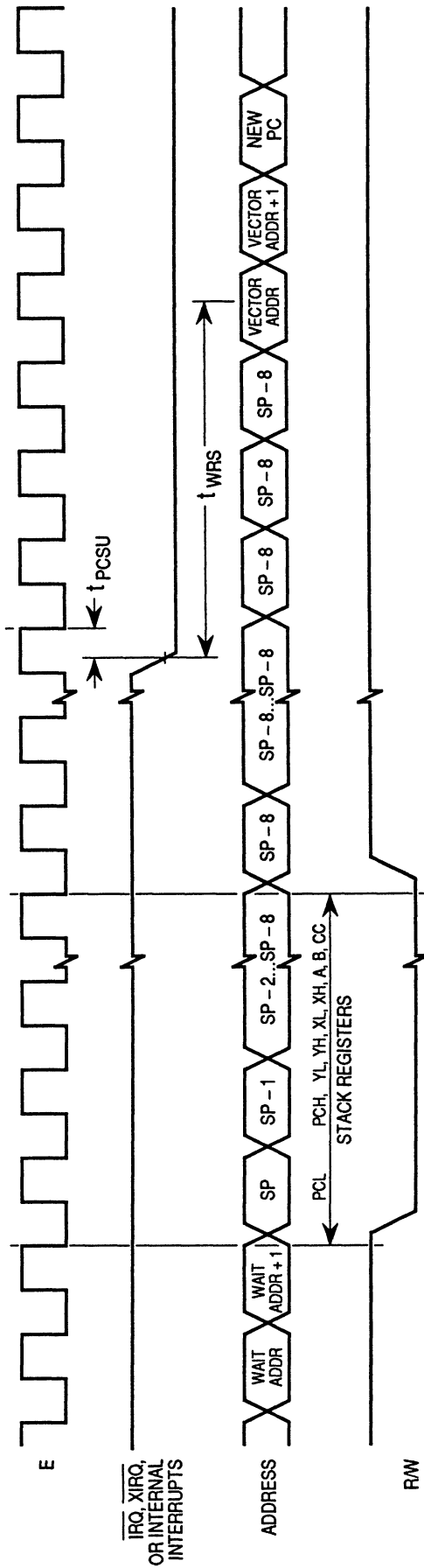

NOTE: \overline{RESET} also causes recovery from WAIT.

Figure A-5. WAIT Recovery Timing Diagram

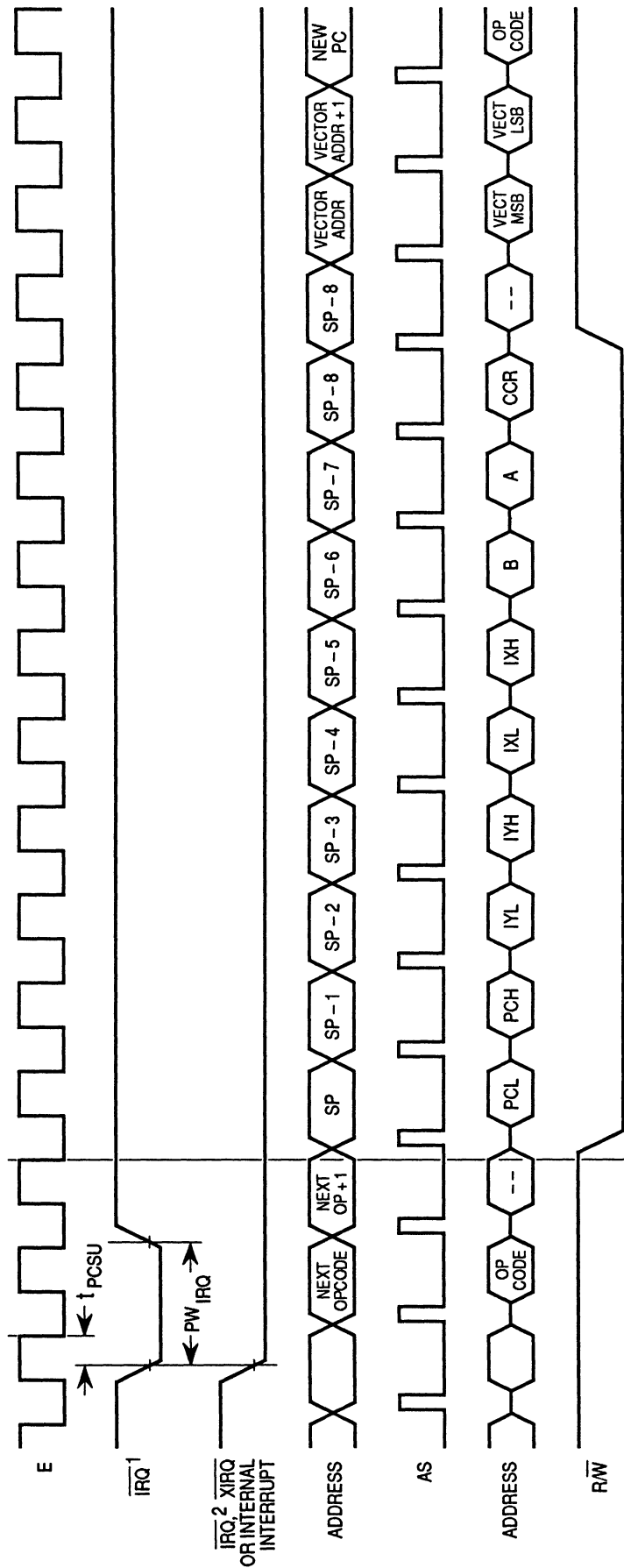

NOTES:

1. Edge sensitive $\overline{\text{IRQ}}$ pin (IRQE bit = 1)
2. Level sensitive $\overline{\text{IRQ}}$ pin (IRQE bit = 0)

Figure A-6. Interrupt Timing Diagram

Table A–5. Peripheral Port Timing

$V_{DD} = 5.0 \text{ Vdc} \pm 10\%$, $V_{SS} = 0 \text{ Vdc}$, $T_A = T_L \text{ to } T_H$

Characteristic	Symbol	1.0 MHz		2.0 MHz		3.0 MHz		Unit
		Min	Max	Min	Max	Min	Max	
Frequency of Operation (E-Clock Frequency)	f_o	dc	1.0	dc	2.0	dc	3.0	MHz
E-Clock Period	t_{cyc}	1000	—	500	—	333	—	ns
Peripheral Data Setup Time (MCU Read of Ports A, C, D, E, and G)	t_{PDSU}	100	—	100	—	100	—	ns
Peripheral Data Hold Time (MCU Read of Ports A, C, D, E, and G)	t_{PDH}	50	—	50	—	50	—	ns
Delay Time, Peripheral Data Write	t_{PWD}							ns
MCU Write to Port A		—	200	—	200	—	200	
MCU Writes to Ports B, C, D, and G $t_{PWD} = 1/4 t_{cyc} + 100 \text{ ns}$		—	350	—	225	—	183	
Input Data Setup Time (Port C)	t_{IS}	60	—	60	—	60	—	ns
Input Data Hold Time (Port C)	t_{IH}	100	—	100	—	100	—	ns
Delay Time, E Fall to STRB $t_{DEB} = 1/4 t_{cyc} + 100 \text{ ns}$	t_{DEB}	—	350	—	225	—	183	ns
Setup Time, STRA Asserted to E Fall (Note 1)	t_{AES}	0	—	0	—	0	—	ns
Delay Time, STRA Asserted to Port C Data Output Valid	t_{PCD}	—	100	—	100	—	100	ns
Hold Time, STRA Negated to Port C Data	t_{PCH}	10	—	10	—	10	—	ns
Three-State Hold Time	t_{PCZ}	—	150	—	150	—	150	ns

NOTES:

1. If this setup time is met, STRB acknowledges in the next cycle. If it is not met, the response may be delayed one more cycle.
2. Port C and D timing is valid for active drive (CWOM and DWOM bits not set in PIOC and SPCR registers respectively).
3. All timing is shown with respect to 20% V_{DD} and 70% V_{DD} , unless otherwise noted.

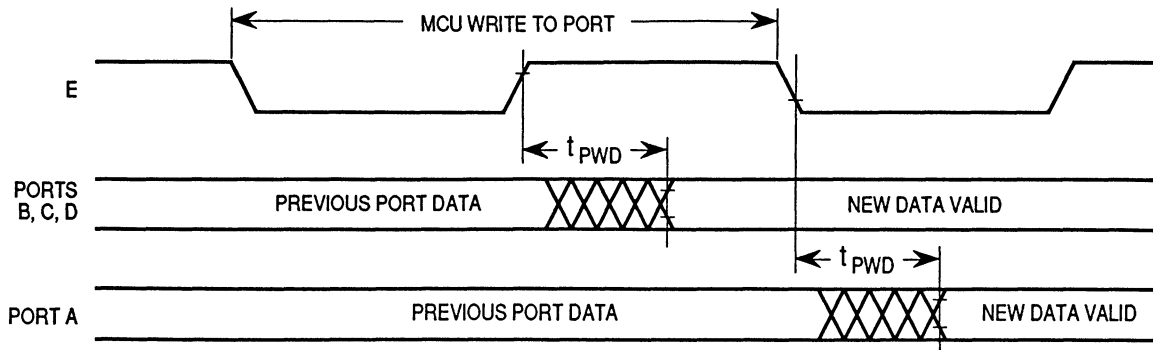

Figure A-7. Port Write Timing Diagram

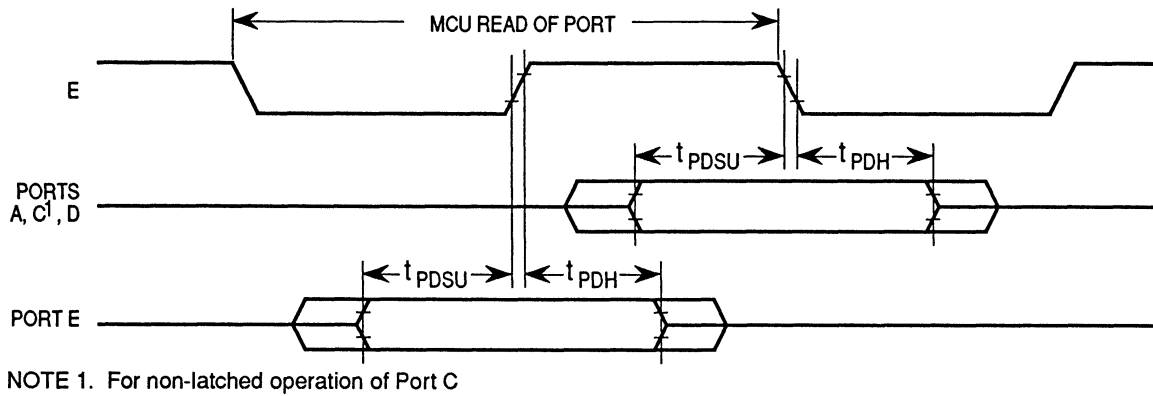

Figure A-8. Port Read Timing Diagram

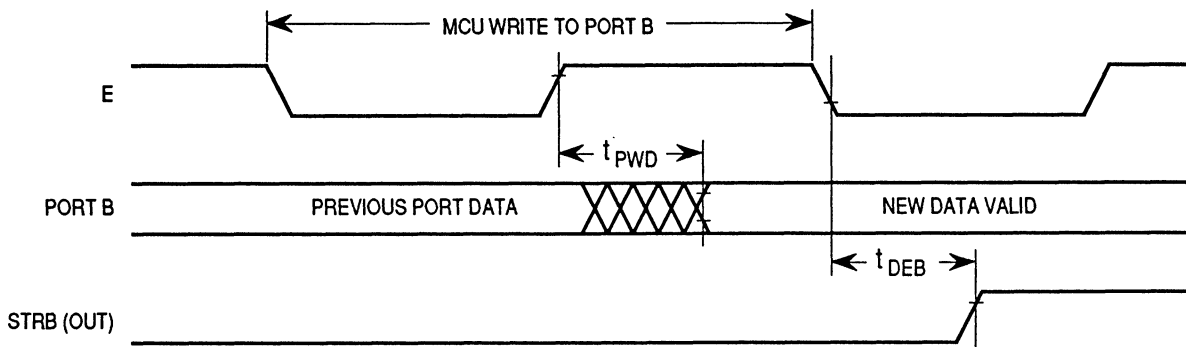

Figure A-9. Simple Output Strobe Timing Diagram

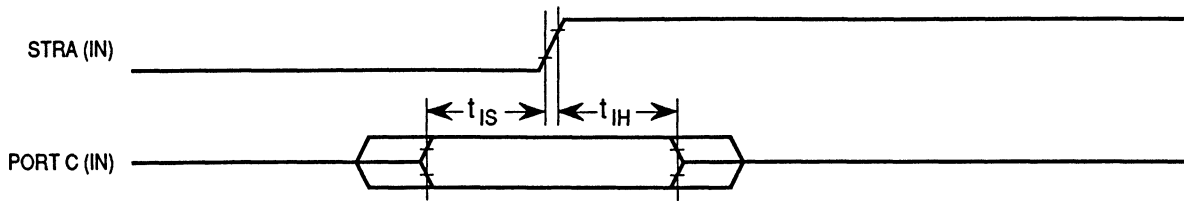
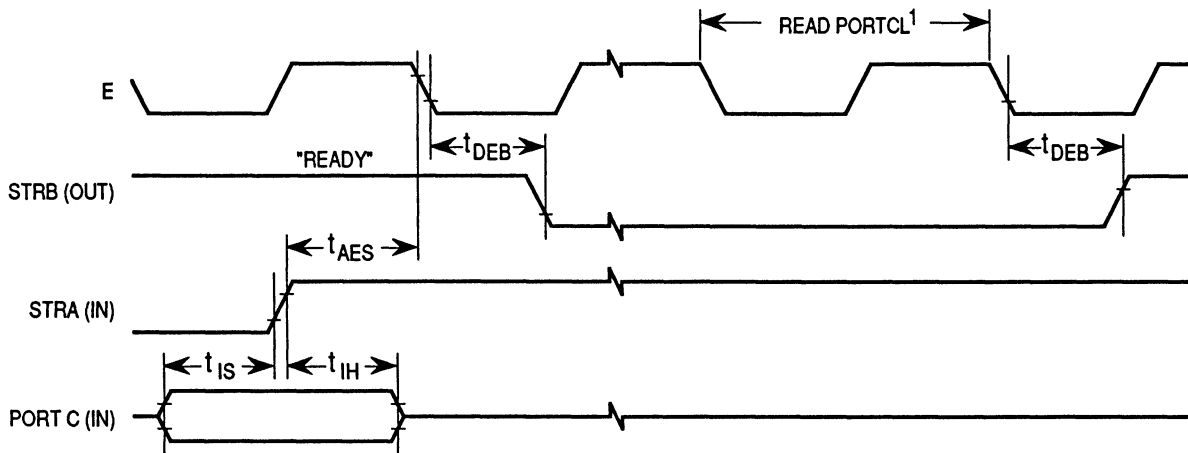

Figure A-10. Simple Input Strobe Timing Diagram



NOTES:

1. After reading PIOC with STAF set
2. Figure shows rising edge STRA (EGA = 1) and high true STRB (INVB = 1).

Figure A-11. Port C Input Handshake Timing Diagram

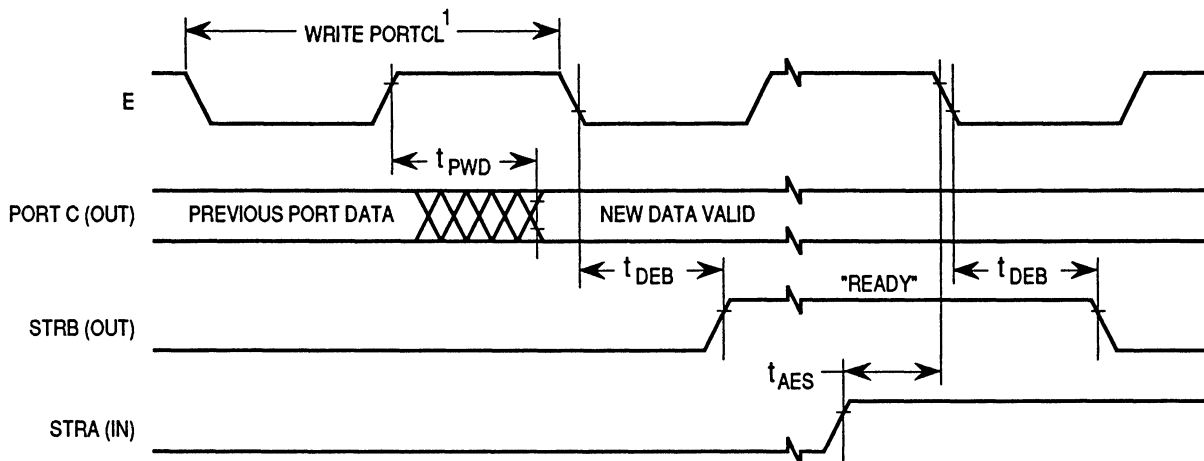

NOTES:

1. After reading PIOC with STAF set
2. Figure shows rising edge STRA (EGA = 1) and high true STRB (INVB = 1).

Figure A-12. Port C Output Handshake Timing Diagram

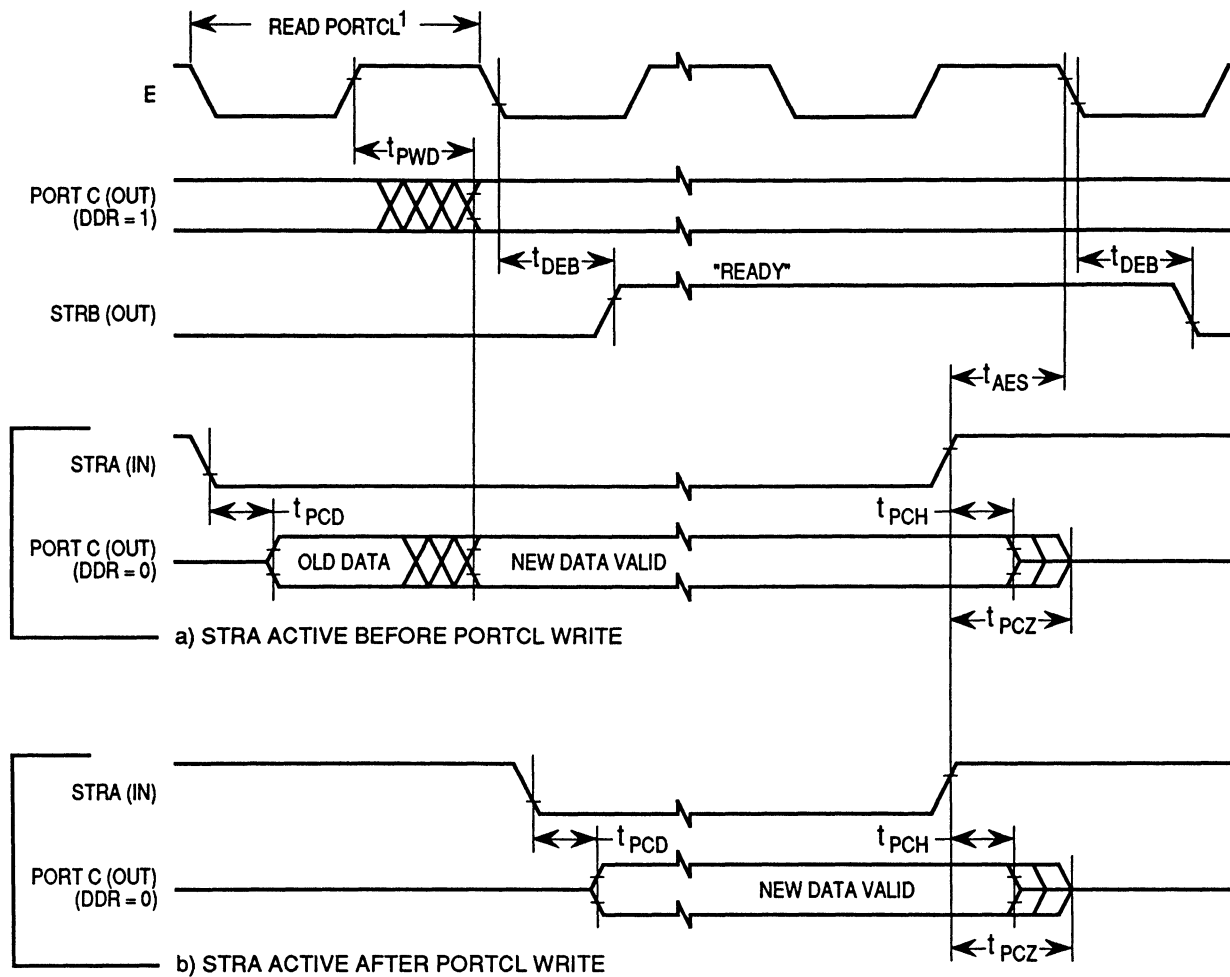

NOTES:

1. After reading PIOC with STAF set
2. Figure shows rising edge STRA (EGA = 1) and high true STRB (INVB = 1).

Figure A-13. Three-State Variation of Output Handshake Timing Diagram (STRA Enables Output Buffer)

Table A–6. Analog-To-Digital Converter Characteristics

$V_{DD} = 5.0 \text{ Vdc} \pm 10\%$, $V_{SS} = 0 \text{ Vdc}$, $T_A = T_L$ to T_H , $750 \text{ kHz} \leq E \leq 3.0 \text{ MHz}$, unless otherwise noted

Characteristic	Parameter	Min	Absolute	2.0 MHz	3.0 MHz	Unit
				Max	Max	
Resolution	Number of Bits Resolved by A/D Converter	—	8	—	—	Bits
Non-Linearity	Maximum Deviation from the Ideal A/D Transfer Characteristics	—	—	$\pm 1/2$	± 1	LSB
Zero Error	Difference Between the Output of an Ideal and an Actual for Zero Input Voltage	—	—	$\pm 1/2$	± 1	LSB
Full Scale Error	Difference Between the Output of an Ideal and an Actual A/D for Full-Scale Input Voltage	—	—	$\pm 1/2$	± 1	LSB
Total Unadjusted Error	Maximum Sum of Non-Linearity, Zero Error, and Full-Scale Error	—	—	$\pm 1/2$	$\pm 1 1/2$	LSB
Quantization Error	Uncertainty Because of Converter Resolution	—	—	$\pm 1/2$	$\pm 1/2$	LSB
Absolute Accuracy	Difference Between the Actual Input Voltage and the Full-Scale Weighted Equivalent of the Binary Output Code, All Error Sources Included	—	—	± 1	± 2	LSB
Conversion Range	Analog Input Voltage Range	V_{RL}	—	V_{RH}	V_{RH}	V
V_{RH}	Maximum Analog Reference Voltage (Note 2)	V_{RL}	—	$V_{DD} + 0.1$	$V_{DD} + 0.1$	V
V_{RL}	Minimum Analog Reference Voltage (Note 2)	$V_{SS} - 0.1$	—	V_{RH}	V_{RH}	V
ΔV_R	Minimum Difference between V_{RH} and V_{RL} (Note 2)	3	—	—	—	V
Conversion Time	Total Time to Perform a Single Analog-to-Digital Conversion: a. E Clock b. Internal RC Oscillator	— —	32 —	— $t_{cyc} + 32$	— $t_{cyc} + 32$	t_{cyc} μs
Monotonicity	Conversion Result Never Decreases with an Increase in Input Voltage and has no Missing Codes		Guaranteed			
Zero Input Reading	Conversion Result when $V_{in} = V_{RL}$	00	—	—	—	Hex
Full Scale Reading	Conversion Result when $V_{in} = V_{RH}$	—	—	FF	FF	Hex
Sample Acquisition Time	Analog Input Acquisition Sampling Time: a. E Clock b. Internal RC Oscillator	— —	12 —	— 12	— 12	t_{cyc} μs
Sample/Hold Capacitance	Input Capacitance during Sample PE0–PE7	—	20 (Typ)	—	—	pF
Input Leakage	Input Leakage on A/D Pins PE0–PE7 V_{RL}, V_{RH}	— —	— —	400 1.0	400 1.0	nA μA

NOTES:

1. Source impedances greater than 10 k Ω affect accuracy adversely because of input leakage.
2. Performance verified down to 2.5 V ΔV_R , but accuracy is tested and guaranteed at $\Delta V_R = 5 \text{ V} \pm 10\%$.

Table A-7. Expansion Bus Timing

$V_{DD} = 5.0 \text{ Vdc} \pm 10\%$, $V_{SS} = 0 \text{ Vdc}$, $T_A = T_L \text{ to } T_H$

Num	Characteristic	Symbol	1.0 MHz		2.0 MHz		3.0 MHz		Unit
			Min	Max	Min	Max	Min	Max	
	Frequency of Operation (E-Clock Frequency)	f_o	dc	1.0	dc	2.0	dc	3.0	MHz
1	Cycle Time	t_{cyc}	1000	—	500	—	333	—	ns
2	Pulse Width, E Low $PW_{EL} = 1/2 t_{cyc} - 23 \text{ ns}$ (Note 1)	PW_{EL}	477	—	227	—	146	—	ns
3	Pulse Width, E High $PW_{EH} = 1/2 t_{cyc} - 28 \text{ ns}$ (Note 1)	PW_{EH}	472	—	222	—	141	—	ns
4a,b	E and AS Rise and Fall Time	t_r t_f	—	20 20	—	20 20	—	20 15	ns
9	Address Hold Time $t_{AH} = 1/8 t_{cyc} - 29.5 \text{ ns}$ (Note 1, 2a)	t_{AH}	95.5	—	33	—	26	—	ns
12	Non-Muxed Address Valid Time to E Rise $t_{AV} = PW_{EL} - (t_{ASD} + 80 \text{ ns})$ (Note 1, 2a)	t_{AV}	281.5	—	94	—	54	—	ns
17	Read Data Setup Time	t_{DSR}	30	—	30	—	30	—	ns
18	Read Data Hold Time (Max = t_{MAD})	t_{DHR}	0	145.5	0	83	0	51	ns
19	Write Data Delay Time $t_{DDW} = 1/8 t_{cyc} + 65.5 \text{ ns}$ (Note 1, 2a)	t_{DDW}	—	190.5	—	128	—	71	ns
21	Write Data Hold Time $t_{DHW} = 1/8 t_{cyc} - 29.5 \text{ ns}$ (Note 1, 2a)	t_{DHW}	95.5	—	33	—	26	—	ns
22	Muxed Address Valid Time to E Rise $t_{AVM} = PW_{EL} - (t_{ASD} + 90 \text{ ns})$ (Note 1, 2a)	t_{AVM}	271.5	—	84	—	54	—	ns
24	Muxed Address Valid Time to AS Fall $t_{ASL} = PW_{ASH} - 70 \text{ ns}$ (Note 1)	t_{ASL}	151	—	26	—	13	—	ns
25	Muxed Address Hold Time $t_{AHL} = 1/8 t_{cyc} - 29.5 \text{ ns}$ (Note 1, 2b)	t_{AHL}	95.5	—	33	—	31	—	ns
26	Delay Time, E to AS Rise $t_{ASD} = 1/8 t_{cyc} - 9.5 \text{ ns}$ (Note 1, 2a)	t_{ASD}	115.5	—	53	—	31	—	ns
27	Pulse Width, AS High $PW_{ASH} = 1/4 t_{cyc} - 29 \text{ ns}$ (Note 1)	PW_{ASH}	221	—	96	—	63	—	ns
28	Delay Time, AS to E Rise $t_{ASED} = 1/8 t_{cyc} - 9.5 \text{ ns}$ (Note 1, 2b)	t_{ASED}	115.5	—	53	—	31	—	ns
29	MPU Address Access Time (Note 2a) $t_{ACCA} = t_{cyc} - (PW_{EL} - t_{AVM}) - t_{DSR} - t_f$	t_{ACCA}	744.5	—	307	—	196	—	ns
35	MPU Access Time $t_{ACCE} = PW_{EH} - t_{DSR}$	t_{ACCE}	—	442	—	192	—	111	ns
36	Muxed Address Delay (Previous Cycle MPU Read) $t_{MAD} = t_{ASD} + 30 \text{ ns}$ (Note 1, 2a)	t_{MAD}	145.5	—	83	—	51	—	ns

NOTES:

- Formula only for dc to 2 MHz.
- Input clocks with duty cycles other than 50% affect bus performance. Timing parameters affected by input clock duty cycle are identified by (a) and (b). To recalculate the approximate bus timing values, substitute the following expressions in place of $1/8 t_{cyc}$ in the above formulas, where applicable:
 - $(1-DC) \times 1/4 t_{cyc}$
 - $DC \times 1/4 t_{cyc}$

Where:

DC is the decimal value of duty cycle percentage (high time).

- All timing is shown with respect to 20% V_{DD} and 70% V_{DD} , unless otherwise noted.

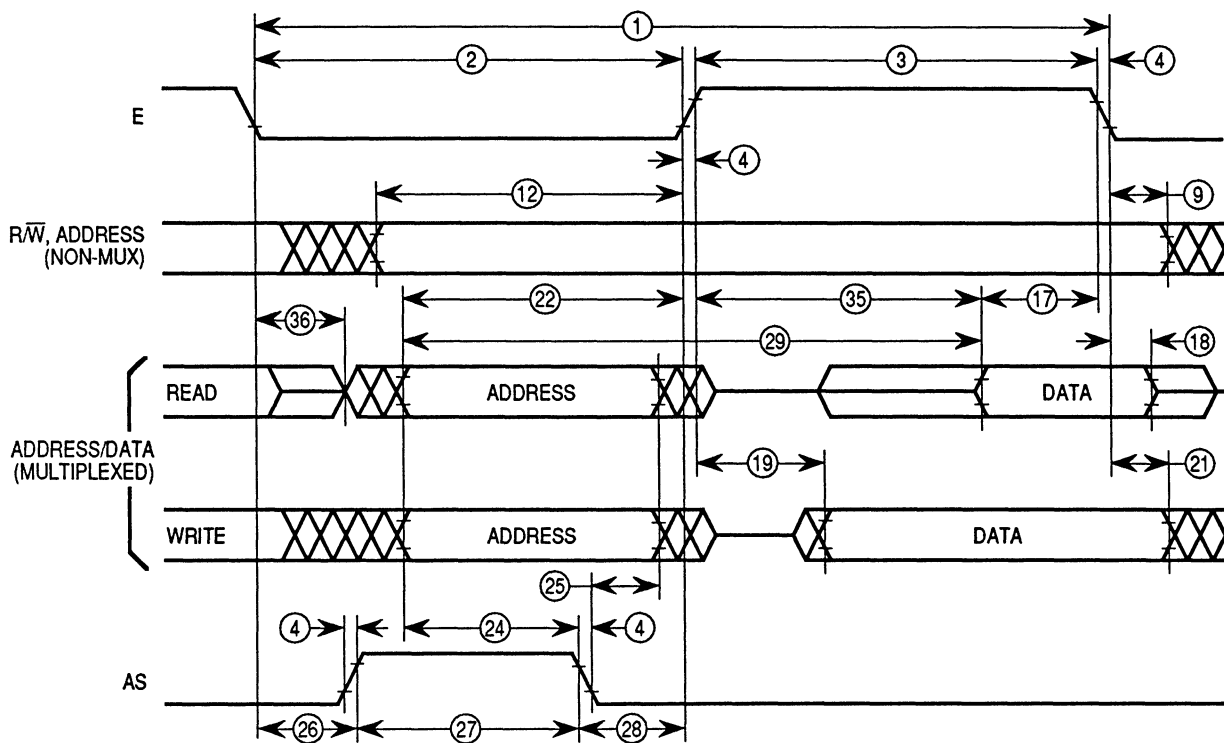

NOTE: Measurement points shown are 20% and 70% of V_{DD}

Figure A-14. Multiplexed Expansion Bus Timing Diagram

Table A–8. Serial Peripheral Interface (SPI) Timing

$V_{DD} = 5.0 \text{ Vdc} \pm 10\%$, $V_{SS} = 0 \text{ Vdc}$, $T_A = T_L \text{ to } T_H$

Num	Characteristic	Symbol	2.0 MHz		3.0 MHz		Unit
			Min	Max	Min	Max	
	Operating Frequency Master Slave	$f_{op(m)}$ $f_{op(s)}$	dc dc	0.5 2.0	dc dc	0.5 3.0	f_{op} MHz
1	Cycle Time Master Slave	$t_{cyc(m)}$ $t_{cyc(s)}$	2.0 500	— —	2.0 333	— —	t_{cyc} ns
2	Enable Lead Time Master (Note 2) Slave	$t_{lead(m)}$ $t_{lead(s)}$	— 250	— —	— 240	— —	ns ns
3	Enable Lag Time Master (Note 2) Slave	$t_{lag(m)}$ $t_{lag(s)}$	— 250	— —	— 240	— —	ns ns
4	Clock (SCK) High Time Master Slave	$t_{w(SCKH)m}$ $t_{w(SCKH)s}$	340 190	— —	227 127	— —	ns ns
5	Clock (SCK) Low Time Master Slave	$t_{w(SCKL)m}$ $t_{w(SCKL)s}$	340 190	— —	227 127	— —	ns ns
6	Data Setup Time (Inputs) Master Slave	$t_{su(m)}$ $t_{su(s)}$	100 100	— —	100 100	— —	ns ns
7	Data Hold Time (Inputs) Master Slave	$t_{h(m)}$ $t_{h(s)}$	100 100	— —	100 100	— —	ns ns
8	Access Time (Time to Data Active from High-Impedance State) Slave	t_a	0	120	0	120	ns
9	Disable Time (Hold Time to High-Impedance State) Slave	t_{dis}	—	240	—	167	ns
10	Data Valid (After Enable Edge) (Note 3)	$t_{v(s)}$	—	240	—	167	ns
11	Data Hold Time (Outputs) (After Enable Edge)	t_{ho}	0	—	0	—	ns
12	Rise Time (20% V_{DD} to 70% V_{DD} , $C_L = 200 \text{ pF}$) SPI Outputs (SCK, MOSI, and MISO) SPI Inputs (SCK, MOSI, MISO, and \overline{SS})	t_{rm} t_{rs}	— —	100 2.0	— —	100 2.0	ns μs
13	Fall Time (70% V_{DD} to 20% V_{DD} , $C_L = 200 \text{ pF}$) SPI Outputs (SCK, MOSI, and MISO) SPI Inputs (SCK, MOSI, MISO, and \overline{SS})	t_{fm} t_{fs}	— —	100 2.0	— —	100 2.0	ns μs

NOTES:

1. All timing is shown with respect to 20% V_{DD} and 70% V_{DD} , unless otherwise noted.
2. Signal production depends on software.
3. Assumes 200 pF load on all SPI pins.

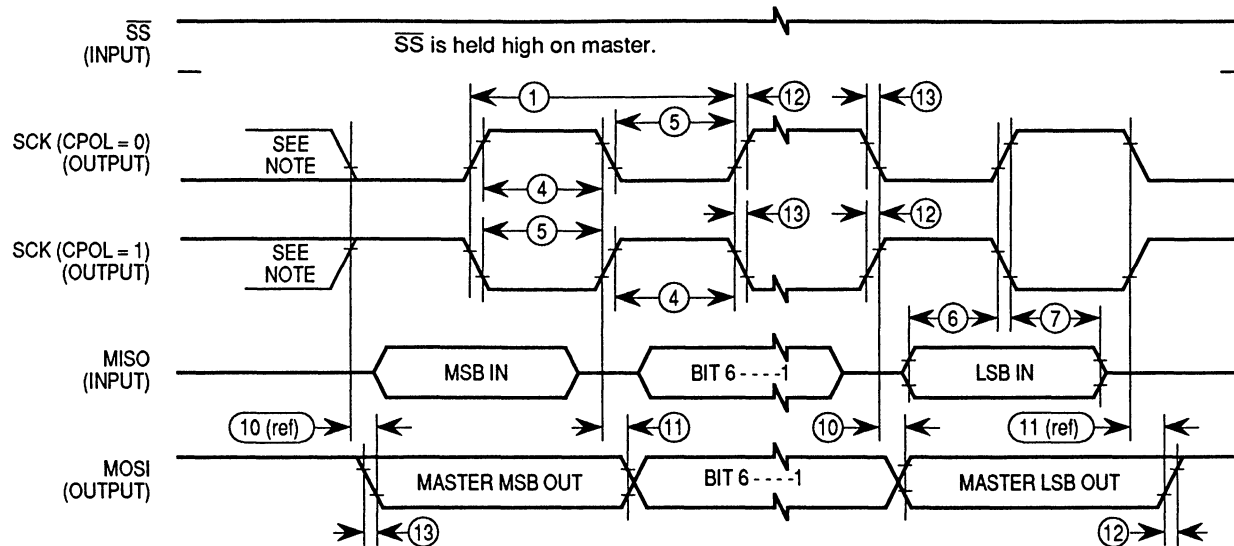

NOTE: This first clock edge is generated internally but is not seen at the SCK pin.

a) SPI Master Timing (CPHA = 0)

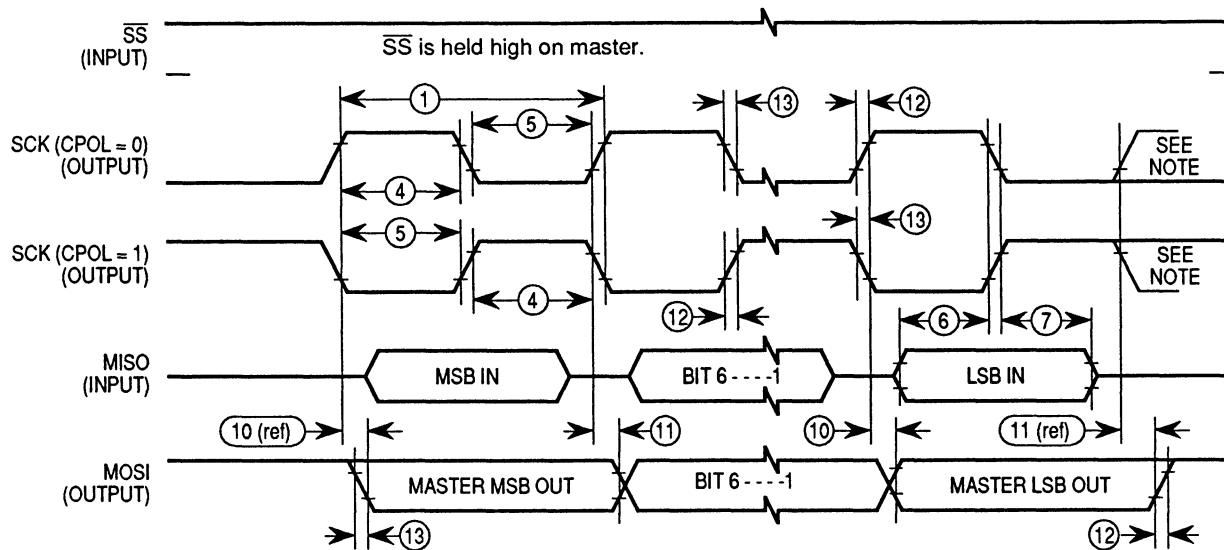

NOTE: This last clock edge is generated internally but is not seen at the SCK pin.

b) SPI Master Timing (CPHA = 1)

Figure A-15. SPI Timing Diagram (1 of 2)

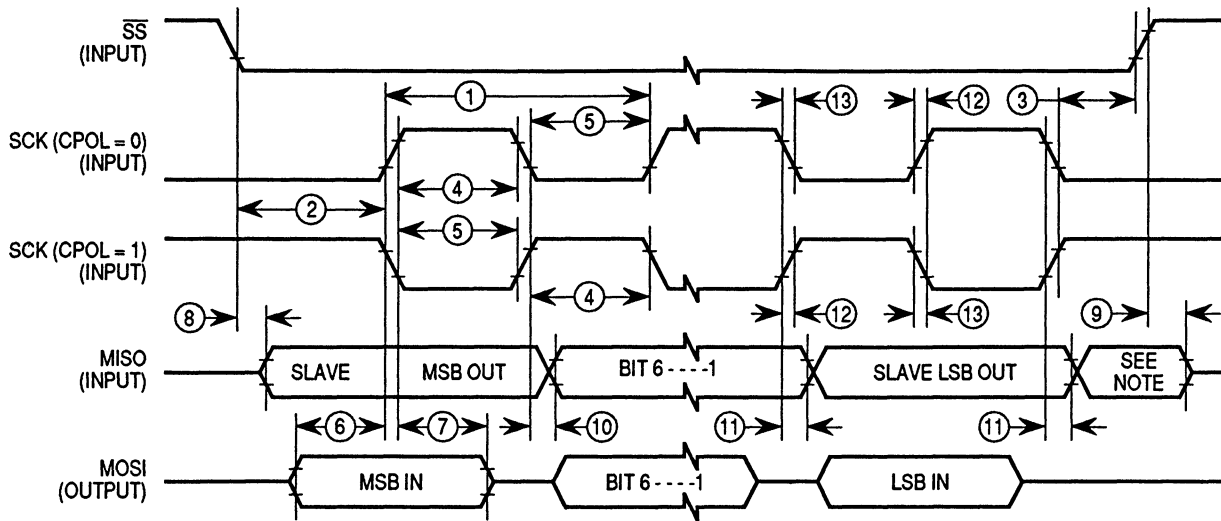

NOTE: Not defined but normally MSB of character just received.

c) SPI Slave Timing (CPHA = 0)

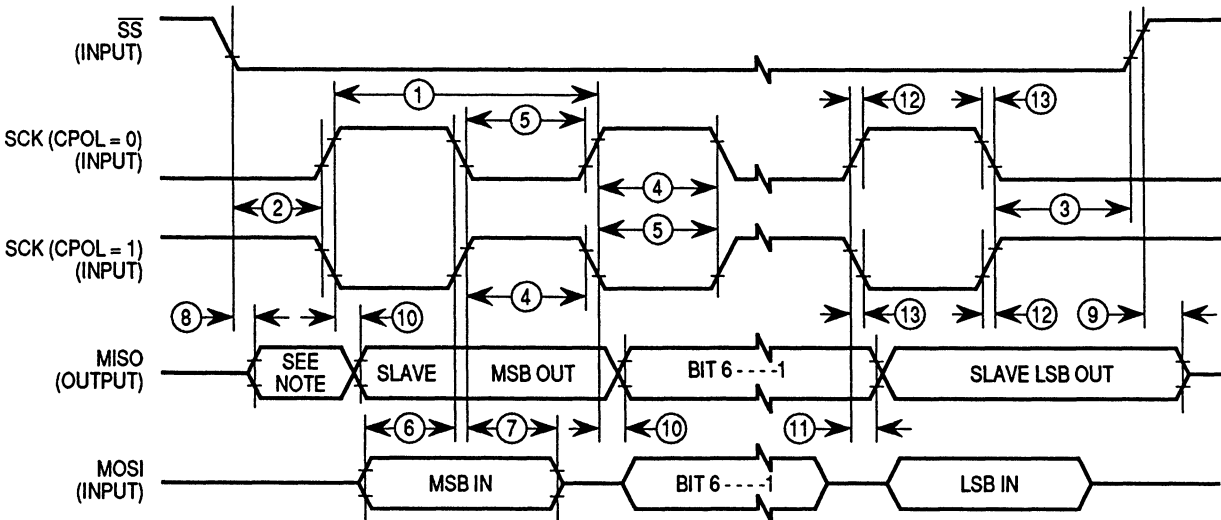

NOTE: Not defined but normally LSB of character previously transmitted.

d) SPI Slave Timing (CPHA = 1)

Figure A-15. SPI Timing Diagram (2 of 2)

Table A–9. EEPROM Characteristics

$V_{DD} = 5.0 \text{ Vdc} \pm 10\%$, $V_{SS} = 0 \text{ Vdc}$, $T_A = T_L \text{ to } T_H$

Characteristic	Temperature Range			Unit
	– 40 to 85° C	– 40 to 105° C	– 40 to 125° C	
Programming Time (Note 1)				ms
<1.0 MHz, RCO Enabled	10	15	20	
1.0 to 2.0 MHz, RCO Enabled	20	Must use RCO	Must use RCO	
≥ 2.0 MHz (or Anytime RCO Enabled)	10	15	20	
Erase Time (Note 1)				ms
Byte, Row and Bulk	10	10	10	
Write/Erase Endurance (Note 2)	10,000	10,000	10,000	Cycles
Data Retention (Note 2)	10	10	10	Years

NOTES:

1. The RC oscillator (RCO) must be enabled (by setting the CSEL bit in the OPTION register) for EEPROM programming and erasure when the E-clock frequency is below 1.0 MHz.
2. Refer to Reliability Monitor Report (current quarterly issue) for current failure rate information.

APPENDIX B MECHANICAL DATA AND ORDERING INFORMATION

B.1 Pin Assignments

The MC68HC711L6 is available in the 68-pin plastic leaded chip carrier (PLCC), the 68-pin windowed cerquad, or the 64-pin quad flat pack (QFP). Refer to Table B-1 for ordering information.

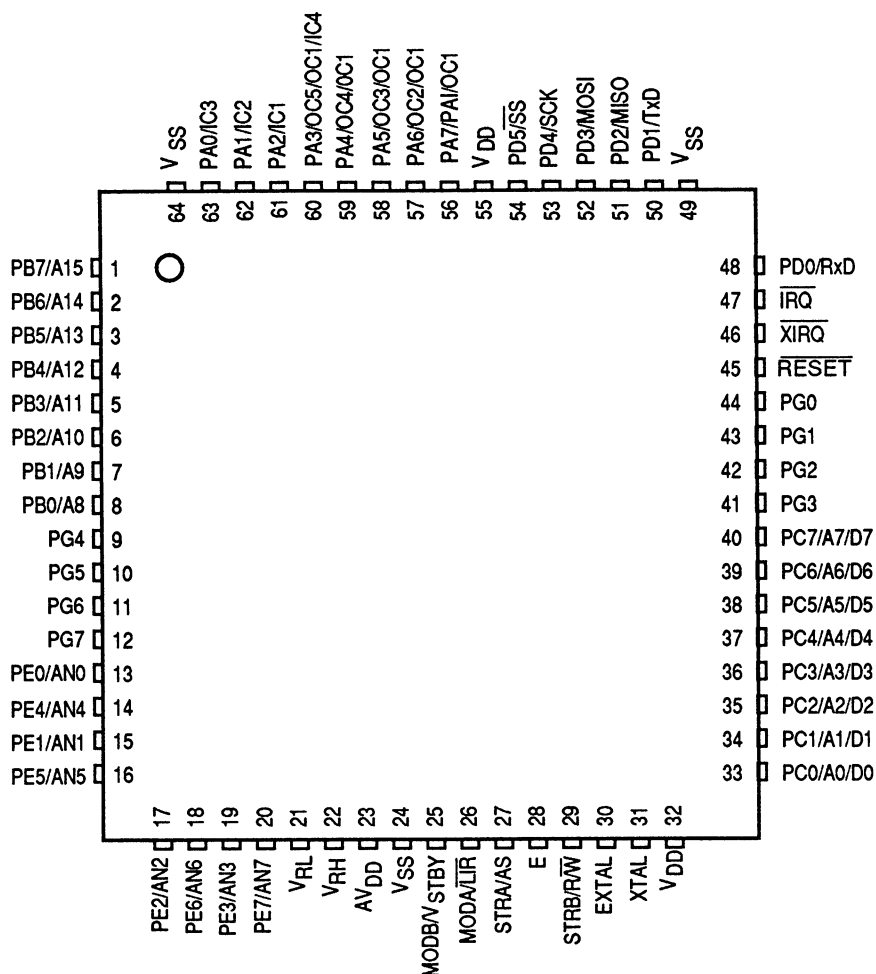

Figure B-1. 64-Pin QFP

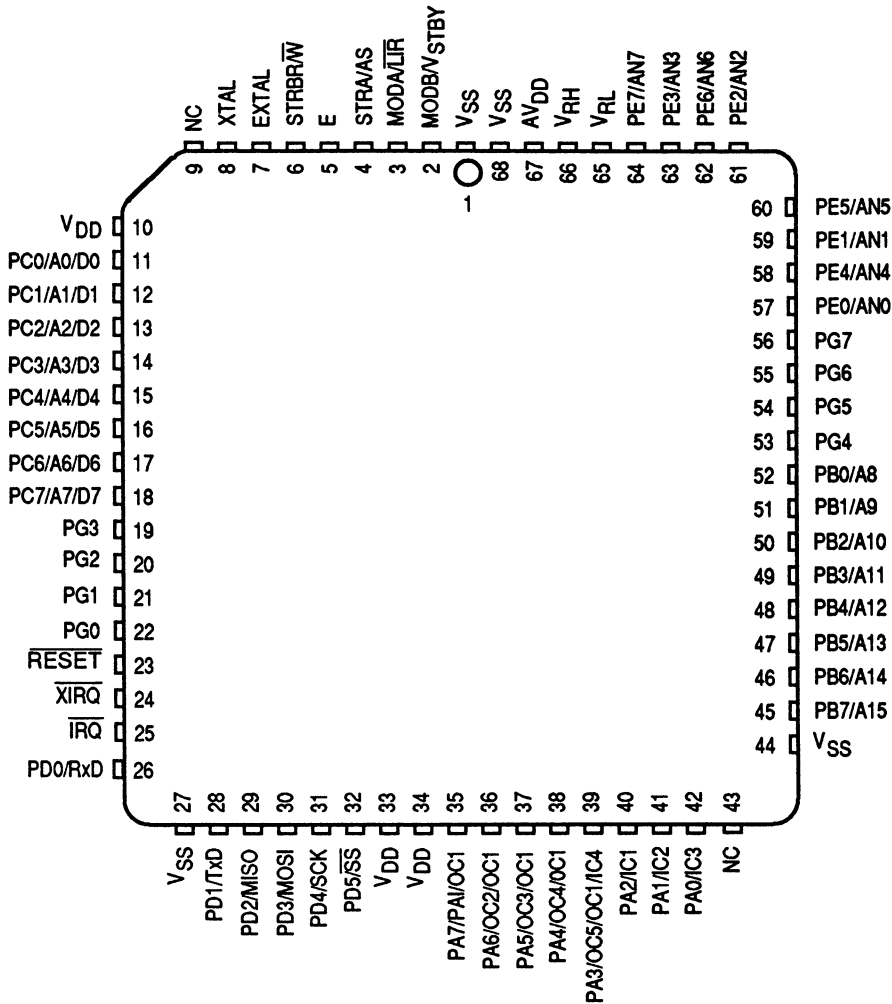

Figure B-2. 68-Pin PLCC/Cerquad

B.2 Package Dimensions

Figures B-3, B-4, and B-5 show the HC711L6 in case outline.

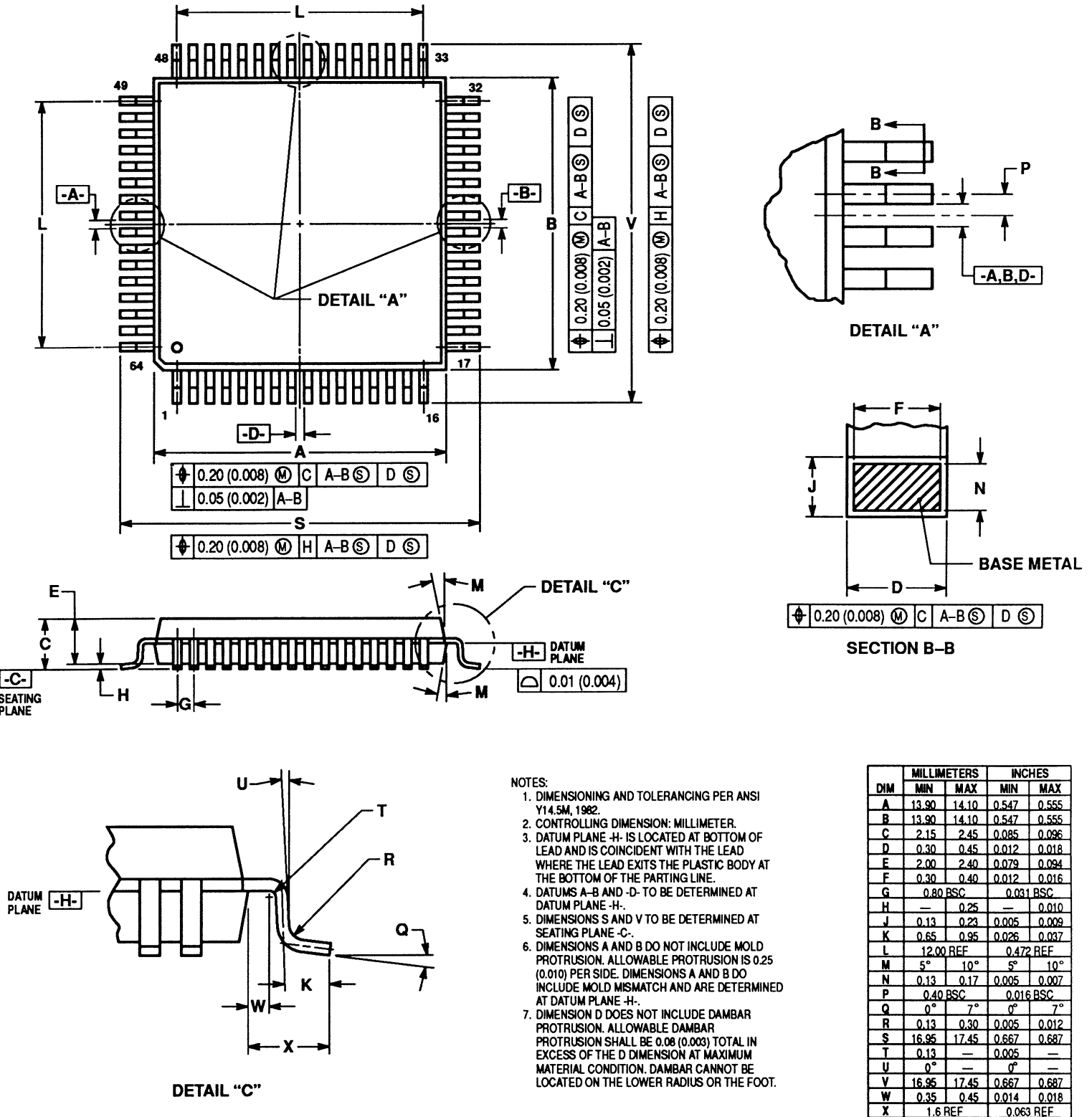
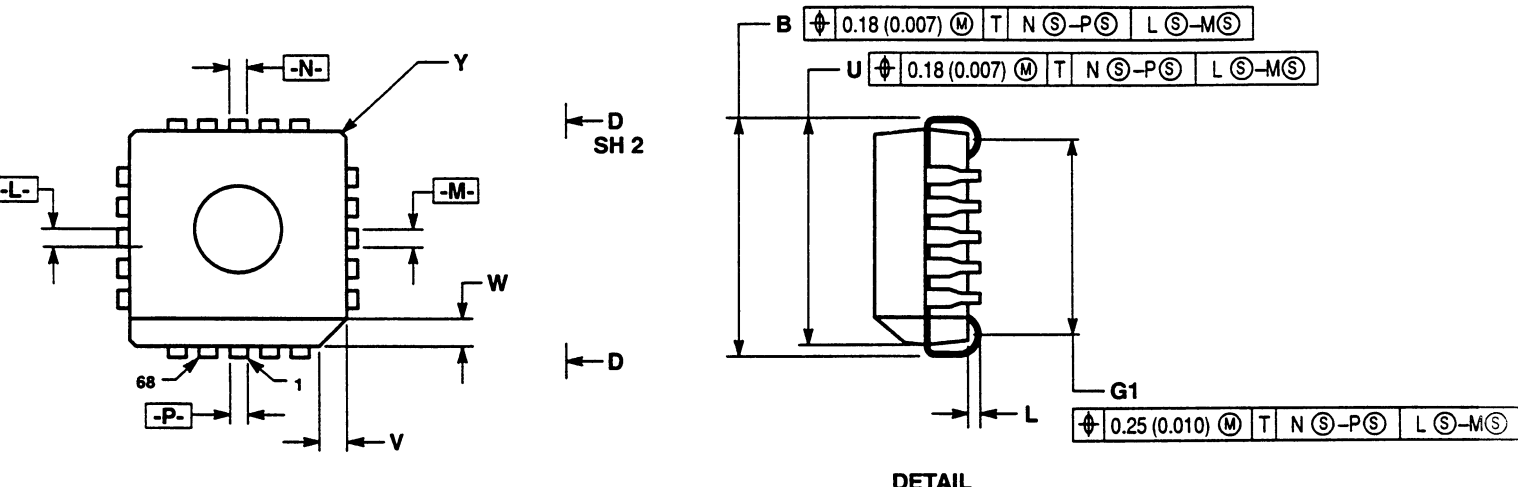
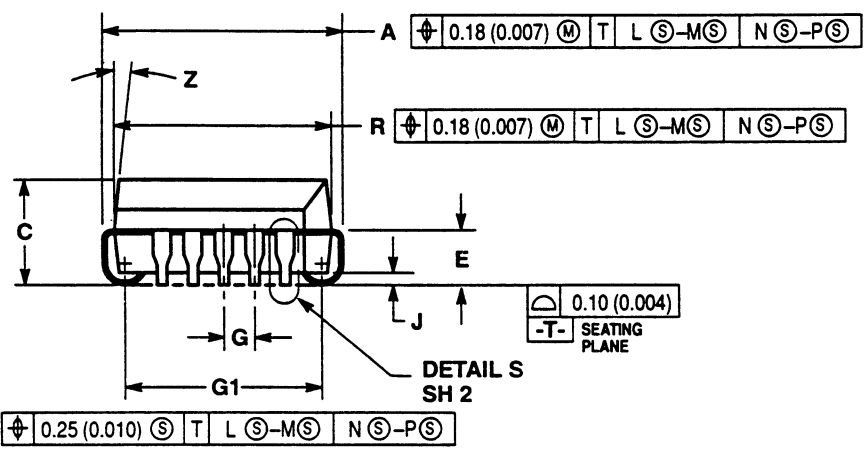

Figure B-3. Case Outline #840B-01



DETAIL



DETAIL S
SH 2

- NOTES:
1. DUE TO SPACE LIMITATION, CASE 779A-01 SHALL BE REPRESENTED BY A GENERAL (SMALLER) CASE OUTLINE DRAWING RATHER THAN SHOWING ALL 68 LEADS.
 2. DATUMS -L-, -M-, -N-, AND -P- DETERMINED WHERE TOP OF LEAD SHOULDER EXITS PACKAGE BODY AT GLASS PARTING LINE.
 3. DIM G1, TRUE POSITION TO BE MEASURED AT DATUM -T-, SEATING PLANE.
 4. DIM R AND U DO NOT INCLUDE GLASS PROTRUSION. ALLOWABLE GLASS PROTRUSION IS 0.25 (0.010) PER SIDE.
 5. DIMENSIONING AND TOLERANCING PER ANSI Y14.5M, 1982.
 6. CONTROLLING DIMENSION: INCH.

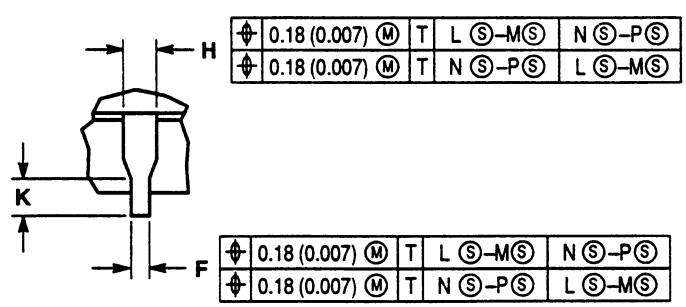

DETAIL S

DIM	MILLIMETERS		INCHES	
	MIN	MAX	MIN	MAX
A	25.02	25.27	0.985	0.995
B	25.02	25.27	0.985	0.995
C	3.94	5.06	0.155	0.200
E	2.29	3.05	0.090	0.120
F	0.43	0.48	0.017	0.021
G	1.27 BSC		0.050 BSC	
H	0.66	0.81	0.026	0.032
J	0.51	—	0.020	—
K	1.27 BSC		0.050 BSC	
L	0.08	—	0.003	—
R	23.62	24.33	0.930	0.958
U	23.62	24.33	0.930	0.958
V	0.91	1.12	0.036	0.044
W	0.91	1.12	0.036	0.044
G1	22.61	23.62	0.890	0.930

Figure B-4. Case Outline #779A-01

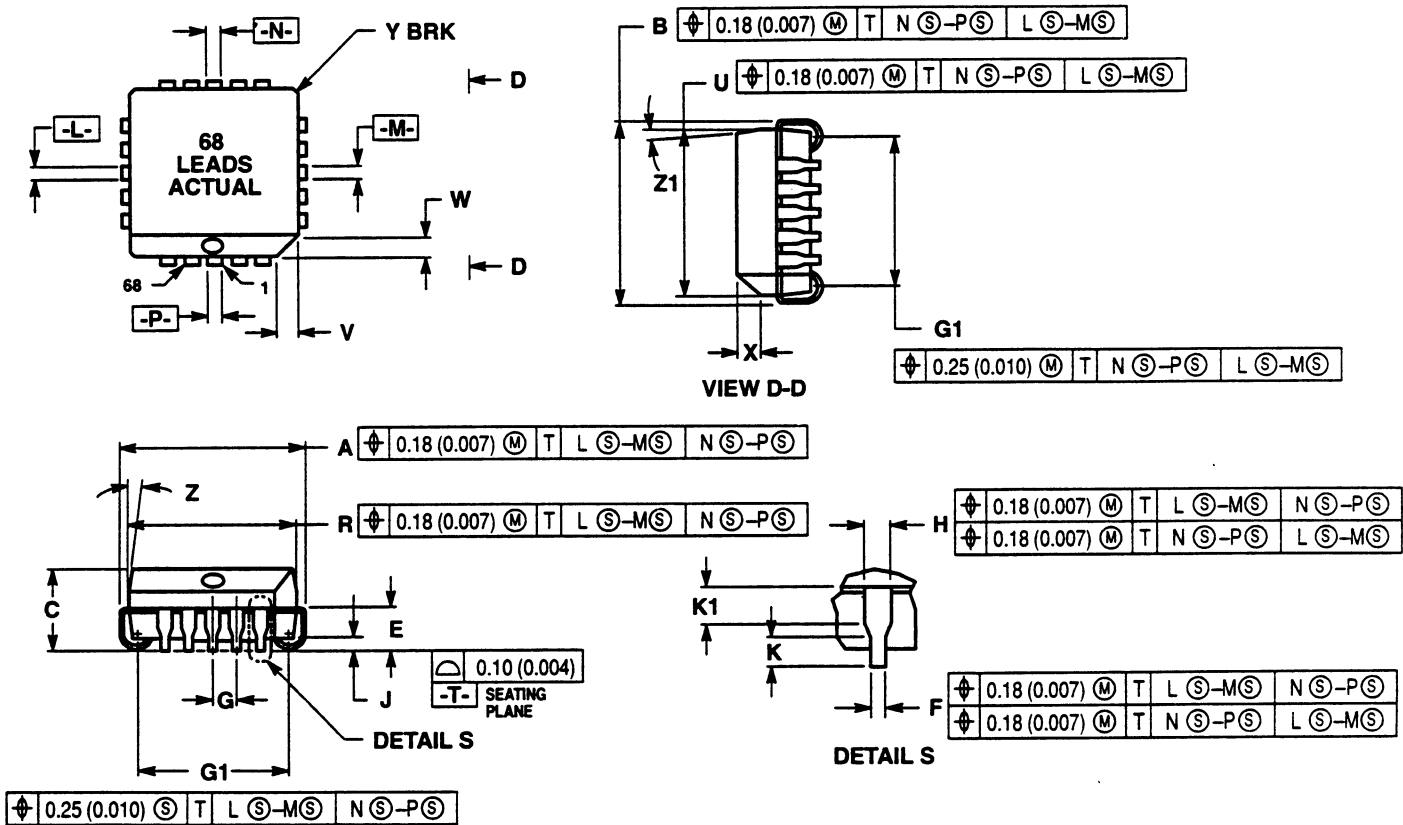

DIM	MILLIMETERS		INCHES	
	MIN	MAX	MIN	MAX
A	25.02	25.27	0.985	0.995
B	25.02	25.27	0.985	0.995
C	4.20	4.57	0.165	0.180
E	2.29	2.79	0.090	0.110
F	0.33	0.48	0.013	0.019
G	1.27 BSC		0.050 BSC	
H	0.66	0.81	0.026	0.032
J	0.51	—	0.020	—
K	0.64	—	0.025	—
R	24.13	24.28	0.950	0.956
U	24.13	24.28	0.950	0.956
V	1.07	1.21	0.042	0.048
W	1.07	1.21	0.042	0.048
X	1.07	1.42	0.042	0.056
Y	—	0.50	—	0.020
Z	2°	10°	2°	10°
G1	23.12	23.62	0.910	0.930
K1	1.02	—	0.040	—
Z1	2°	10°	2°	10°

- NOTES:
1. DUE TO SPACE LIMITATION, CASE 779-02 SHALL BE REPRESENTED BY A GENERAL (SMALLER) CASE OUTLINE DRAWING RATHER THAN SHOWING ALL 68 LEADS.
 2. DATUMS -L-, -M-, -N-, AND -P- DETERMINED WHERE TOP OF LEAD SHOULDER EXIT PLASTIC BODY AT MOLD PARTING LINE.
 3. DIM G1, TRUE POSITION TO BE MEASURED AT DATUM -T-, SEATING PLANE.
 4. DIM R AND U DO NOT INCLUDE MOLD PROTRUSION. ALLOWABLE MOLD PROTRUSION IS 0.25 (0.010) PER SIDE.
 5. DIMENSIONING AND TOLERANCING PER ANSI Y14.5M, 1982.
 6. CONTROLLING DIMENSION: INCH.
 7. 779-01 IS OBSOLETE, NEW STANDARD 779-02.

Figure B-5. Case Outline #779-02

B.3 Mechanical Data and Ordering Information

Add the proper suffix, from Table B-1, to the MC68HC (11- OR 711-) MCU number to specify the appropriate device when placing an order.

Table B-1. Ordering Information

MCU	Package	Temperature	Description	Suffix
L6	68-Pin PLCC	- 40 to +85°C	Buffalo ROM	FN1
	64-Pin Quad Flat Pack	- 40 to +85°C	Buffalo ROM	FU1
7L6	68-Pin PLCC	- 40 to +85°C	Buffalo ROM	FN1
	64-Pin Quad Flat Pack	- 40 to +85°C	Buffalo ROM	FU
	68-Pin Windowed Cerquad	- 40 to +85°C	UV EPROM	FS

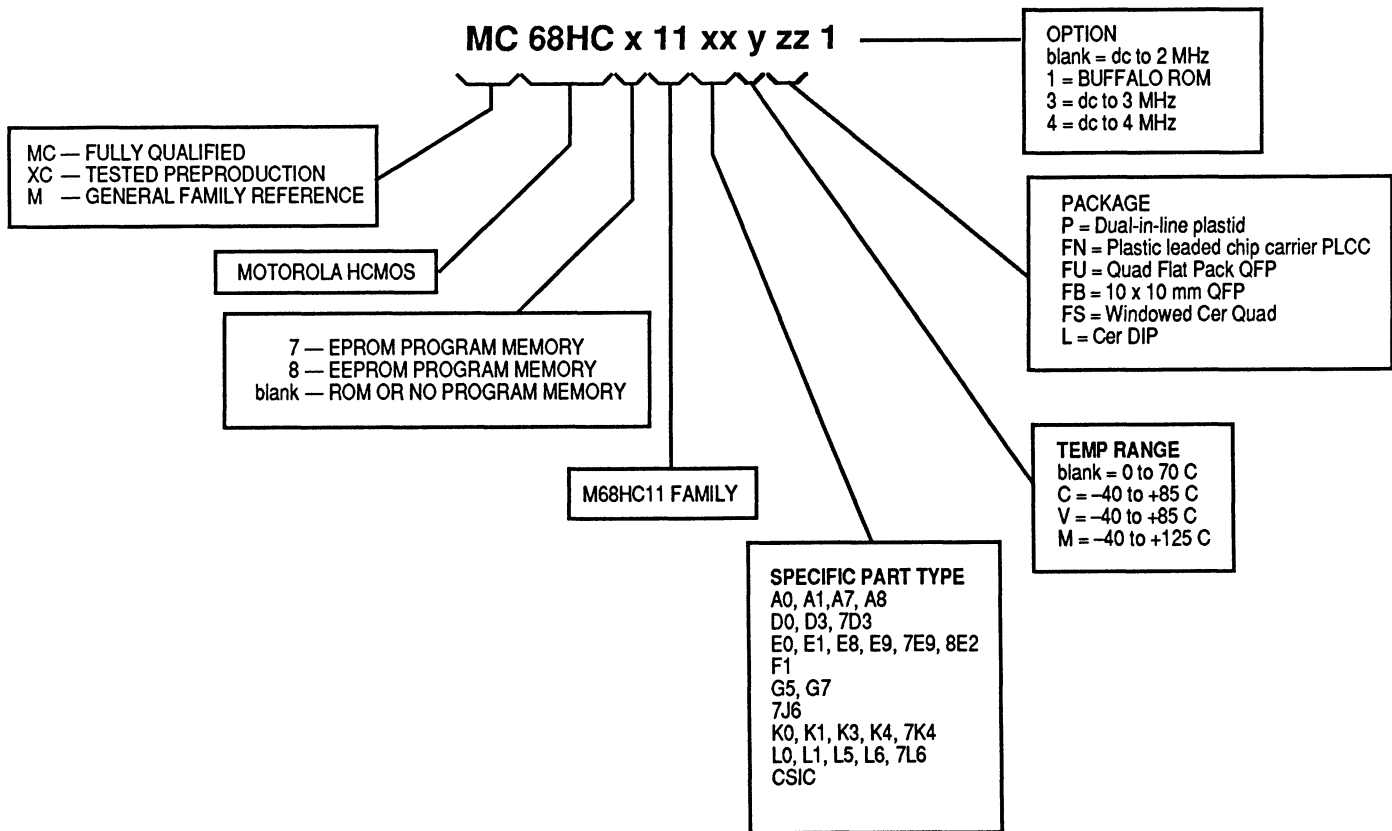

Figure B-6. Part Number Options

APPENDIX C DEVELOPMENT SUPPORT

C.1 Development System Tools

Motorola has developed several tools for use in debugging and evaluating MC68HC11 equipment. Table C-1 lists those development tools that are available for use with the MC68HC711L6. For information about Motorola and third party development system hardware and software, contact your Motorola sales representative.

C.2 M68HC11L6EVS — Evaluation System

Refer to the *M68HC11L6EVS Evaluation System User's Manual*, document number M68HC11EVS/D1. The evaluation system (EVS) is an economical tool used to debug and evaluate the MC68HC11L series MCU-based target system equipment. The EVS is designed to operate in either debugging or evaluation mode.

C.2.1 EVS Features

- A low cost way to debug user assembled code and evaluate target systems that incorporate MC68HC11 MCUs.
- One-line assembler/disassembler
- Host computer downloading capability
- Dual Memory Maps
 - 64 Kbyte monitor map with 32 Kbytes of monitor EPROM
 - MC68HC11L6 user map that includes 64 Kbytes of emulation RAM
- OTPROM, EPROM, and EEPROM MCU programmer
- MCU extension I/O port for single-chip, expanded multiplexed, and special test operation modes
- Logic analyzer connector
- RS-232C compatible terminal/host computer I/O ports

Motorola reserves the right to make changes without further notice to any products herein. Motorola makes no warranty, representation or guarantee regarding the suitability of its products for any particular purpose, nor does Motorola assume any liability arising out of the application or use of any product or circuit, and specifically disclaims any and all liability, including without limitation consequential or incidental damages. "Typical" parameters which may be provided in Motorola data sheets and/or specifications can and do vary in different applications and actual performance may vary over time. All operating parameters, including "Typicals" must be validated for each customer application by customer's technical experts. Motorola does not convey any license under its patent rights nor the rights of others. Motorola products are not designed, intended, or authorized for use as components in systems intended for surgical implant into the body, or other applications intended to support or sustain life, or for any other application in which the failure of the Motorola product could create a situation where personal injury or death may occur. Should Buyer purchase or use Motorola products for any such unintended or unauthorized application, Buyer shall indemnify and hold Motorola and its officers, employees, subsidiaries, affiliates, and distributors harmless against all claims, costs, damages, and expenses, and reasonable attorney fees arising out of, directly or indirectly, any claim of personal injury or death associated with such unintended or unauthorized use, even if such claim alleges that Motorola was negligent regarding the design or manufacture of the part. Motorola and  are registered trademarks of Motorola, Inc. Motorola, Inc. is an Equal Opportunity/Affirmative Action Employer.

Mfax is a trademark of Motorola, Inc.

How to reach us:

USA/EUROPE/Locations Not Listed: Motorola Literature Distribution;
P.O. Box 5405, Denver, Colorado 80217. 303-675-2140 or 1-800-441-2447

JAPAN: Nippon Motorola Ltd.: SPD, Strategic Planning Office, 4-32-1,
Nishi-Gotanda, Shinagawa-ku, Tokyo 141, Japan. 81-3-5487-8488

Mfax™: RMFAX0@email.sps.mot.com – TOUCHTONE 602-244-6609
– US & Canada ONLY 1-800-774-1848

ASIA/PACIFIC: Motorola Semiconductors H.K. Ltd.; 8B Tai Ping Industrial Park,
51 Ting Kok Road, Tai Po, N.T., Hong Kong. 852-26629298

INTERNET: <http://motorola.com/sps>



MOTOROLA

14TX31017-2 PRINTED IN USA 7/97 IMPERIAL LITHO 31018 5,000 LITAMCU

MC68HC711L6/D