

Contents

Features.....	1
Block Diagram.....	1
Pin Assignment	2
Description of Terminals.....	2
Description of Operation.....	3
1.Serial interface	3
2.Command configuration	7
3.Initialization	11
4.Processing of none-existent data and end-of-month.....	12
5.Interrupt	13
6.Power voltage detecting circuit	15
7.Example of software treatment	16
Samples of Applied Circuits.....	17
Dimensional Outline Diagram.....	18
Order Specification	18
Adjustment of Oscillating Frequency.....	19
1.Configuration of the oscillating circuit	19
2.Measurement of oscillating frequencies	19
3.Adjustment of oscillating frequencies	20
Absolute Maximum Ratings	21
Recommended Operating Conditions.....	21
Oscillation Characteristics	21
DC Electrical Characteristics.....	22
AC Electrical Characteristics.....	24
Sample of Characteristics	25

S-3530A is a CMOS real-time clock IC supporting an I²C-BUS, which is designed to transfer or set each data of a clock and calendar as requested by a CPU. It provides connection with a CPU via two wires and has two systems of an interrupt/alarm feature, allowing the alleviation of software treatment on the side of a host.

It also works on lower power with the oscillating circuit operated at a constant voltage. Its package uses an extremely small and thin type of eight-pin SSOP.

■ Features

- Low power consumption : 0.7 μ A typ. ($V_{DD}=3.0$ V)
- Wide area of operating voltage : 1.7 to 5.5 V
- BCD input/output of year, month, day, day of a week, hour, minute and second
- CPU interface via two wires(I²C- BUS)
- Auto calendar till the year of 2,099 (automatic leap year arithmetic feature included)
- Built-in power voltage detecting circuit
- Built-in constant voltage circuit
- Built-in flag generating circuit on power on/off
- Built-in alarm interrupter (two systems)
- Steady-state interrupt frequency/duty setting feature
- Built-in 32 KHZ crystal oscillating circuit (Internal Cd, External Cg)
- 8-pin SSOP package (terminal pitch: 0.65 mm)

(*) I²C-BUS is a trademark of PHILLIPS ELECTRONICS N.V.

■ Applications

- Cellular phone
- PHS
- A variety of pagers
- TV set and VCR
- Camera

■ Block Diagram

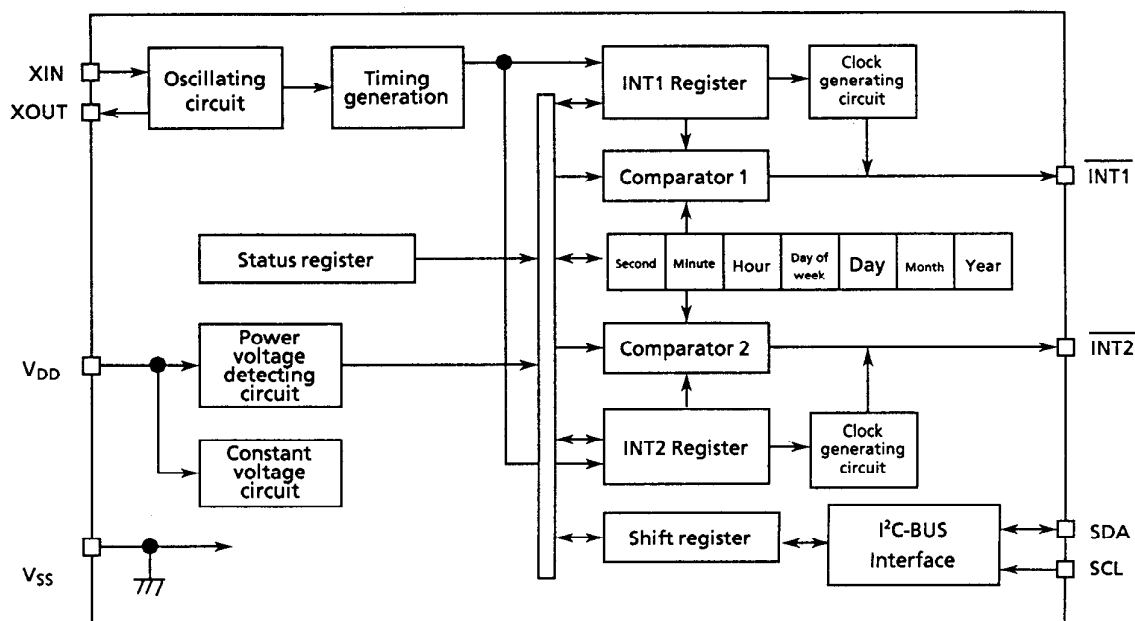

Figure 1 Block diagram

■ Pin Assignment

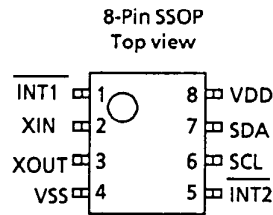

Figure 2 Pin assignment

■ Description of Terminals

Terminal Num.	Abbreviation	Description	Configuration
1	INT1	Alarm interrupt 1 output terminal. Depending on the mode set by the INT1 register and status register, it outputs low or Clock when time is reached. It is disabled by rewriting the status register.	N-channel open drain output (No protective diode on the side of VDD)
2	XIN	Crystal oscillator connect terminal (32,768 HZ) (Internal Cd, External Cg)	—
3	XOUT		
4	VSS	Negative power supply terminal (GND)	—
5	INT2	Alarm interrupt 2 output terminal. Depending on the mode set by the INT2 register and status register, it outputs low or Clock when time is reached. It is disabled by rewriting the status register.	N-channel open drain output (No protective diode on the side of VDD)
6	SCL	Serial clock input terminal. Follow the specification with great care to the rising/falling time of the SCL signal because the signal is treated at its rising/falling edge.	CMOS input (No protective diode on the side of VDD)
7	SDA	Serial data input/output terminal. It is normally used with pulled up to VDD charge via resistance and wired or connected to other devices with open drain or open collector output	N-channel open drain output (No protective diode on the side of VDD) CMOS input
8	VDD	Positive power supply terminal.	—

Table 1 Description of terminals

■ Description of Operation

1. Serial interface

S-3530A receives various commands through the I²C-BUS-based serial interface to read/write data. The method of I²C-BUS-based transfer is described here.

1-1. Start condition

When the SCL line is on the "H" level, the line changes from "H" to "L" so that the start condition is obtained. All the operations begin at the start condition.

1-2. Stop condition

When the SCL line is on the "H" level, the line changes from "L" to "H" so that the stop condition is reached. During a read sequence, any read operation is stopped and a device enters its stand-by mode when a stop condition is received.

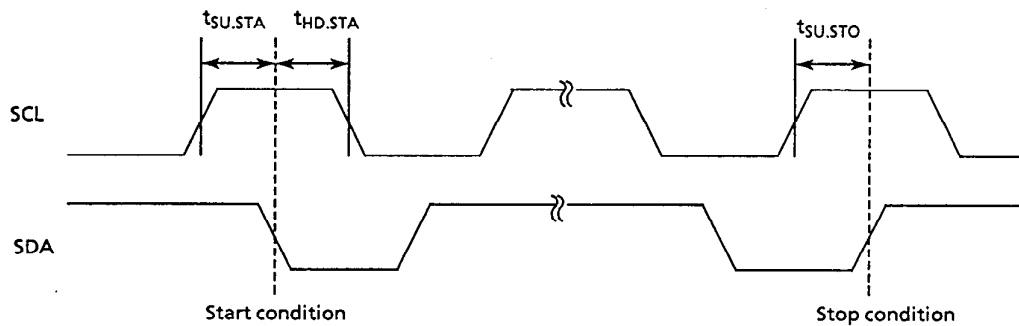

Figure 3 Start/Stop condition

1-3. Data transfer

When the SDA line is changed while it is on "L", data transfer is performed.

When the SDA line is changed while it is on "H", a start or stop condition is recognized.

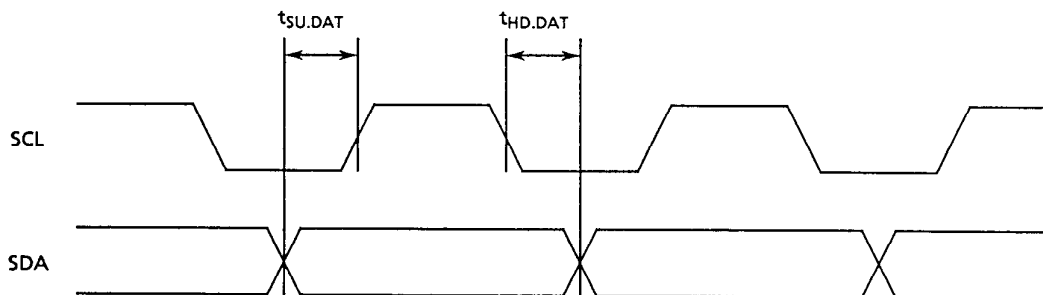

Figure 4 Data transfer timing

1-4. Acknowledge

Data transfer is performed in eight-bit sequence. A device on the system bus, which succeedingly receives data during a period of a ninth clock cycle, puts the SDA line on "L" and returns an acknowledge signal meaning that the data has been received.

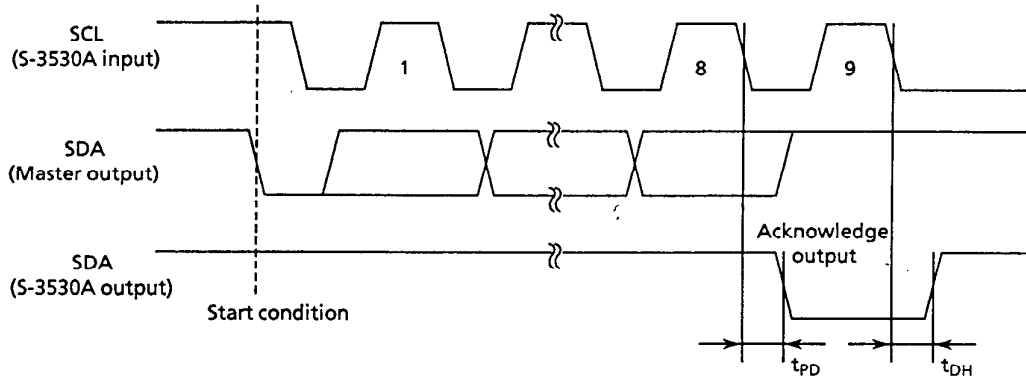

Figure 5 Acknowledge output timing

1-5. Device addressing

The master device on the system generates a start condition to its slave device to make communication. It continuously issues the device address of a four-bit length, the command of a three-bit length and the read/write command of a one-bit length over the SDA bus.

The upper four bits, called a device code, represent a device address and are fixed at "0110".

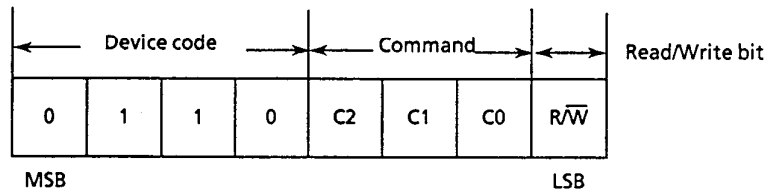
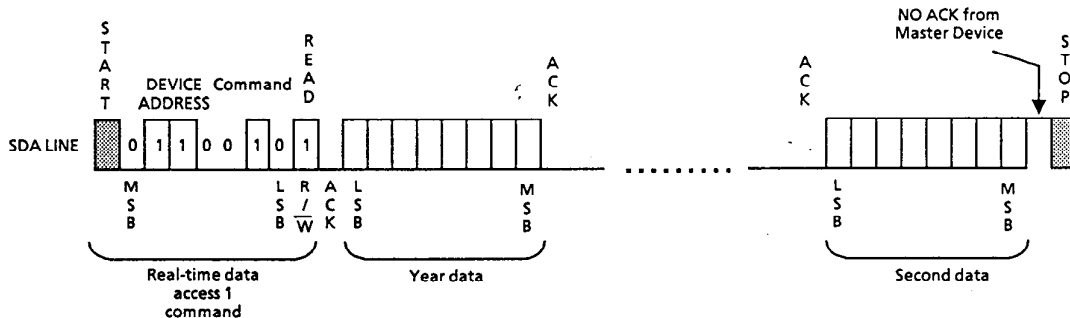

Figure 6 Communication data

1-6.Data reading

After a start condition is detected from the outside, the device code and command are received. At this point, the real-time reading mode or status register reading mode is entered when the read/write bit is "1". In either the real-time reading mode or status register reading mode, data are output in the order from LSB.

(1)Real-time data reading 1



(2)Real-time data reading 2

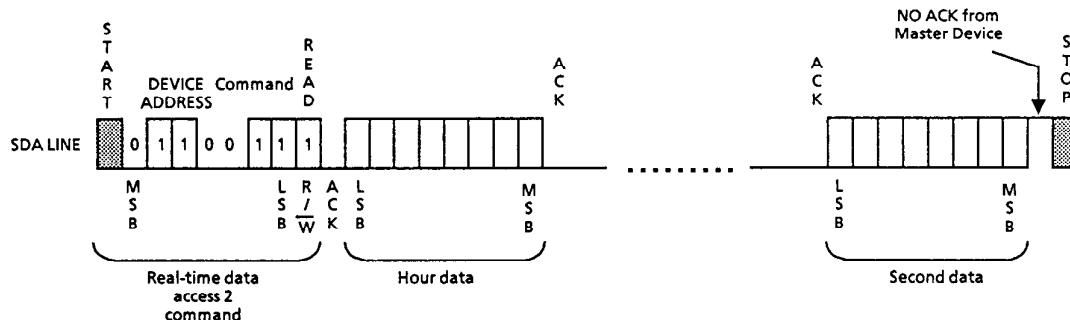

(3)Status register reading

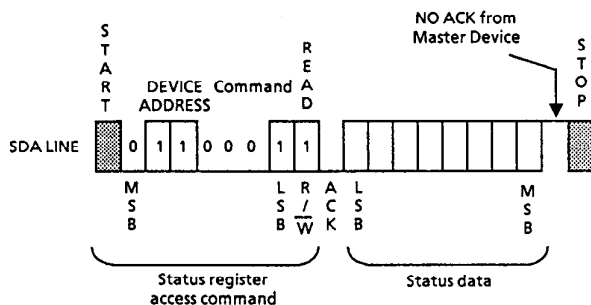

«NOTE»
ACK Upside :Generate from S-3530A
Underside:Generate from Master device

Figure 7 Read communication

1-7. Data writing

After a start condition is detected from the outside, the device code and command are received. At this point, the real-time data writing mode or other register writing mode is entered when the read/write bit is "0". Data must be entered in the order from LSB of the real-time data writing mode or status register writing mode.

In real-time data writing, the count of a calendar and time is reset when the ACK signal rises following the real-time writing command, and any update operation is disabled. After a minute data is received, the end of a month is corrected while a second data is imported. Then, the count is started when the ACK signal rises after the second data is received.

(1) Real-time data writing 1

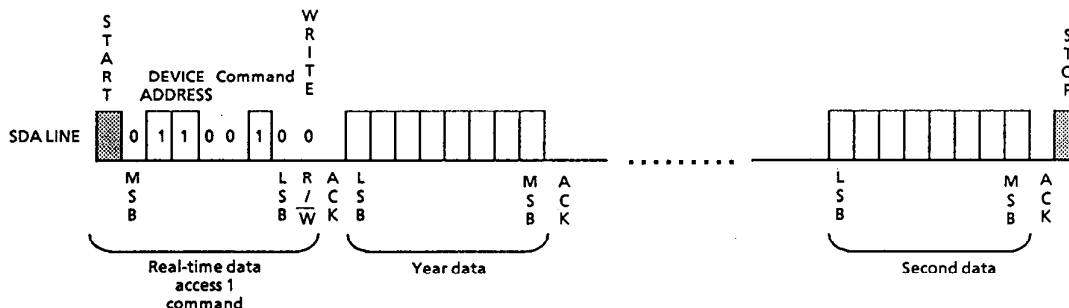

(2) Real-time data writing 2

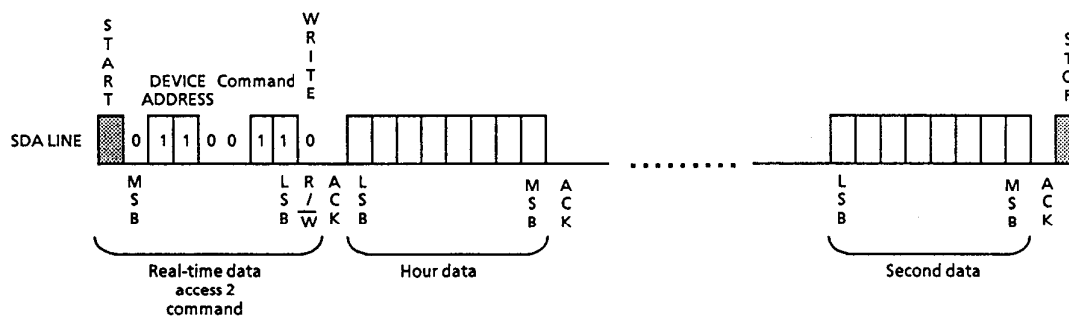

(3) Status register writing

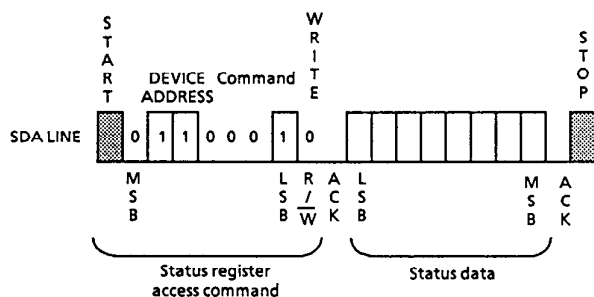

Figure 8 Write communication

2. Command configuration

There are eight commands by which the read/write operation of various registers is performed. The table below lists them.

C2	C1	C0	Description	Number of ACK
0	0	0	Reset (00 (year), 01 (month), 01 (day), 0 (day of week), 00 (minute), 00 (second)) (*1)	1
0	0	1	Status register access	2
0	1	0	Real-time data access 1 (year data to)	8
0	1	1	Real-time data access 2 (hour data to)	4
1	0	0	Alarm time/frequency duty setting 1 (for $\overline{\text{INT1}}$ terminal)	3
1	0	1	Alarm time/frequency duty setting 2 (for $\overline{\text{INT2}}$ terminal)	3
1	1	0	Test mode start (*2)	1
1	1	1	Test mode end (*2)	1

(*1) Don't care the R/\overline{W} bit of this command.

(*2) This command is access-disabled due to specific use for the IC test.

Table 2 Command list

2-1. Real-time data register

The real-time data register is a fifty-six-bit register which stores the BCD code of the data of year, month, day, day of week, hour, minute and second. Any read/write operation performed by the real-time data access command sends or receives the data from LSB on the first digit of the year data.

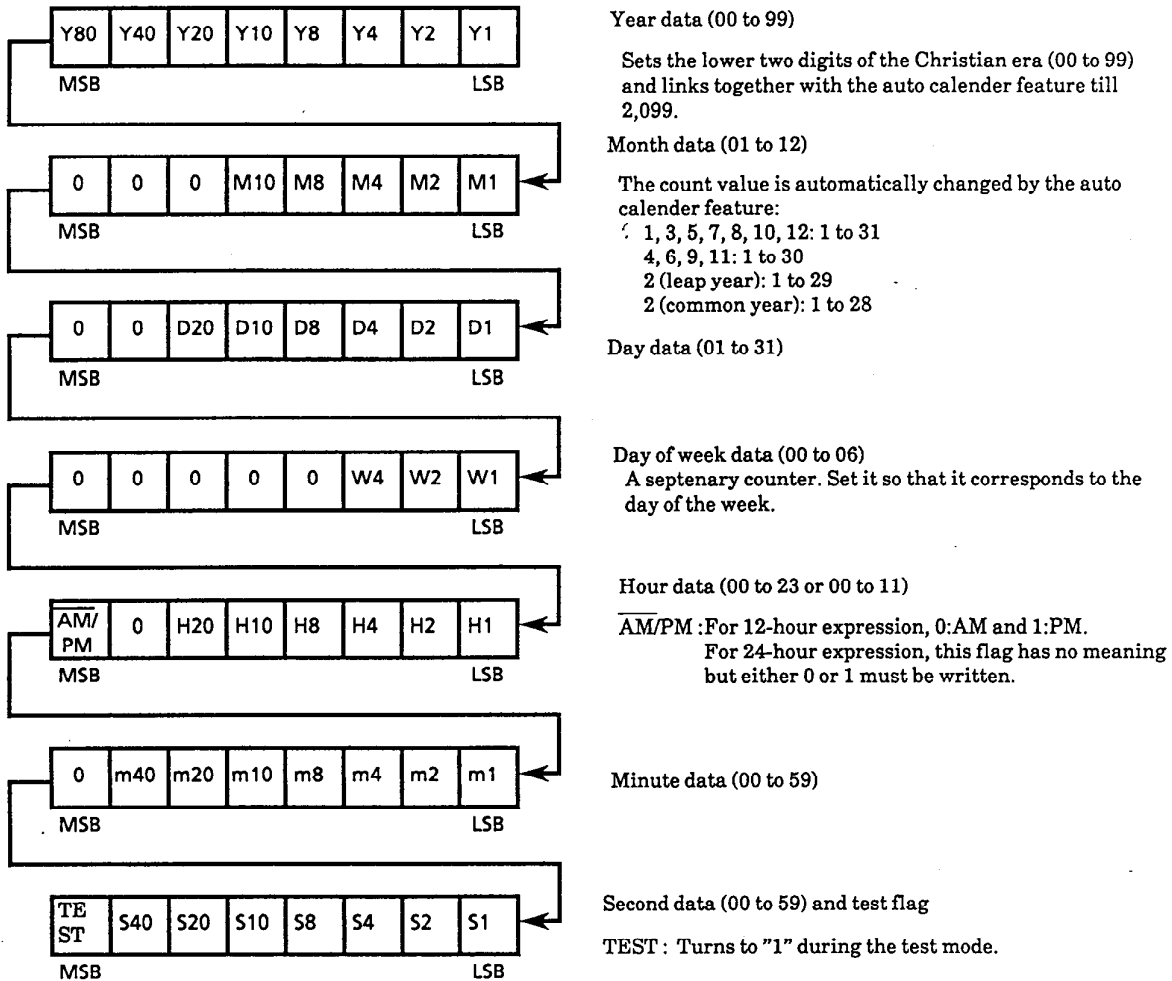

Figure 9 Real-time data register

2-2. Status register

The status register is an eight-bit register which allows you to display and set various modes. The POWER flag is read-only and others are read/write-enabled.

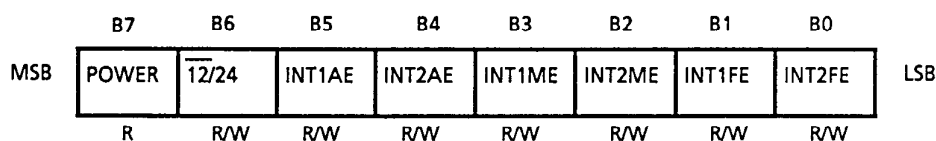

Figure 10 Status register

B7:POWER This flag turns to "1" if the power voltage detecting circuit operates during power-on or changes in power voltage (below VDET). Once turning to "1", this flag does not turn back to "0" even when the power voltage reaches or exceeds the detected voltage. When the flag is "1", you must send the reset command and turn it to "0". It is a read-only flag.

B6: $\overline{12/24}$ This flag is used to set 12-hour or 24-hour expression.
 0 : 12-hour expression
 1 : 24-hour expression

B5:INT1AE, B4:INT2AE

This flag is used to choose the state of $\overline{INT1}$ terminal (or $\overline{INT2}$ terminal) output with interrupt output set. Enable this flag after setting alarm time that forms a meeting condition in the INT1 register (or INT2 register):

- 0 : Alarm interrupt output is disabled.
- 1 : Alarm interrupt output is enabled.

B3:INT1ME, B2:INT2ME

This flag is used to make the output of the $\overline{INT1}$ terminal (or $\overline{INT2}$ terminal) per-minute edge interrupt or per-minute steady interrupt. To make the output per-minute steady interrupt, set "1" at INT1ME and INT1FE (or INT2ME and INT2FE).

- 0 : Alarm interrupt or selected frequency steady interrupt output
- 1 : Per-minute edge interrupt or per-minute steady interrupt output

B1:INT1FE, B0:INT2FE

This flag is used to make the output of the $\overline{INT1}$ terminal (or $\overline{INT2}$ terminal) per-minute steady interrupt output (a period of one minute, 50% of duty) or selected frequency steady interrupt. Note that the INT1 register (INT2 register) is considered as the data of frequency/duty if selected frequency steady interrupt is chosen.

- 0 : Alarm interrupt or selected frequency steady interrupt output
- 1 : Per-minute edge interrupt or per-minute steady interrupt output

2-3. Alarm time/Frequency duty setting register

There are two types of alarm time/frequency duty setting registers, sixteen-bit registers, which set alarm time or frequency duty. They are switched by INTxAE or INTxFE register. $\overline{AM/PM}$ flag to be set must be in accordance with 12-hour or 24-hour expression. If $\overline{AM/PM}$ flag is not rightly then set hour data is not met to alarm data. The alarm time/frequency duty setting register is a write-only register.

(1) When INTxAE = 1

INT1 register

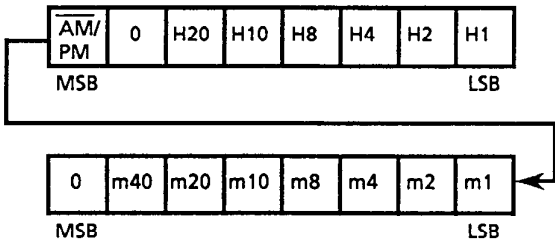

INT2 register

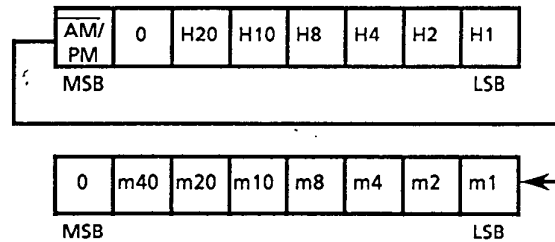

Figure 11 INT1 and INT2 registers (alarm)

INT1 and INT2 registers are considered as alarm time data. Having the same configuration as the time and minutes registers of real-time register configuration, they represent hours and minutes with BCD codes. When setting them, do not set any none-existent day. Data to be set must be in accordance with 12-hour or 24-hour expression that is set at the status register.

(2) When INTxFE = 1

INT1 and INT2 registers are considered as frequency duty data. By turning each bit of the registers to "1", a frequency corresponding to each bit is chosen in an ANDed form.

INT1 register

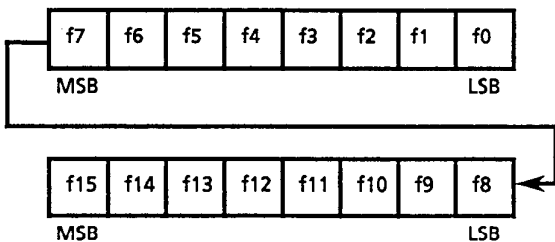

INT2 register

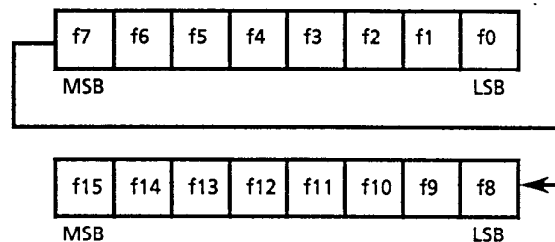

f0	32768HZ	f4	2048HZ	f8	128HZ	f12	8HZ
f1	16384HZ	f5	1024HZ	f9	64HZ	f13	4HZ
f2	8192HZ	f6	512HZ	f10	32HZ	f14	2HZ
f3	4096HZ	f7	256HZ	f11	16HZ	f15	1HZ

Figure 12 INT1 and INT2 registers (frequency duty)

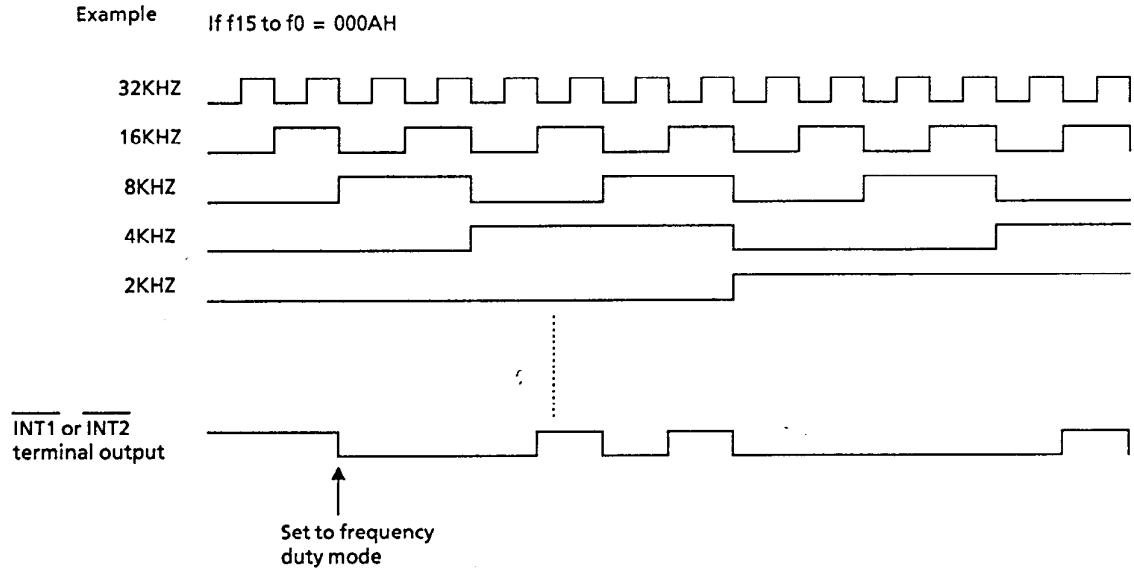

Figure 13 Clock output

2-4. Test flag

The test flag is a one-bit register which is assigned to MSB of the second data of the real-time data register. If a transferred data is considered as the test mode starting data due to the receiving of the test mode starting data or noises, "1" is set. When "1" is set, you must send the test mode ending command or reset command.

3. Initialization

Note that S-3530A has different initializing operations, depending on states.

3-1. When power is turned on

When power is turned on, the status register is set to "82h" and the INT1 register to "8000h" by the power-on detecting circuit. In other words, "1" is sets at the bit 7 (POWER flag) of the status register and the clock of 1HZ is output from the $\overline{\text{INT1}}$ terminal. This is provided to adjust oscillating frequencies. In normal use, the reset command must be sent when power is turned on.

Real-time data register : 00 (year), 01 (month), 01 (day), 0 (day of week), 00 (hour), 00 (minute), 00 (second)
 Status register : "82h"
 INT1 register : "8000h" INT2 register : "0000h"

3-2. When the power voltage detecting circuits operates

The power voltage detecting circuit included in S-3530A operates and sets "1" at the bit 7 (POWER flag) of the internal status register when power is turned on or power voltage is reduced. Once "1" is set, it is held even after the power voltage gets equal to or higher than the detected power voltage. When the flag has "1", you must send the reset command from CPU and initialize the flag. At this point, other registers does not change.

However, if the POWER flag has "0" during the power-on reset of CPU (S-3530A does not reach any indefinite area during backup), you do not have to send the reset command.

3-3. When the reset command is received

When the reset command is received, each register turns as follows:

Real-time data register : 00 (year), 01 (month), 01 (day), 0 (day of week), 00 (hour), 00 (minute), 00 (second)
 Status register : "00h"
 INT1 register : "0000h" INT2 register : "0000h"

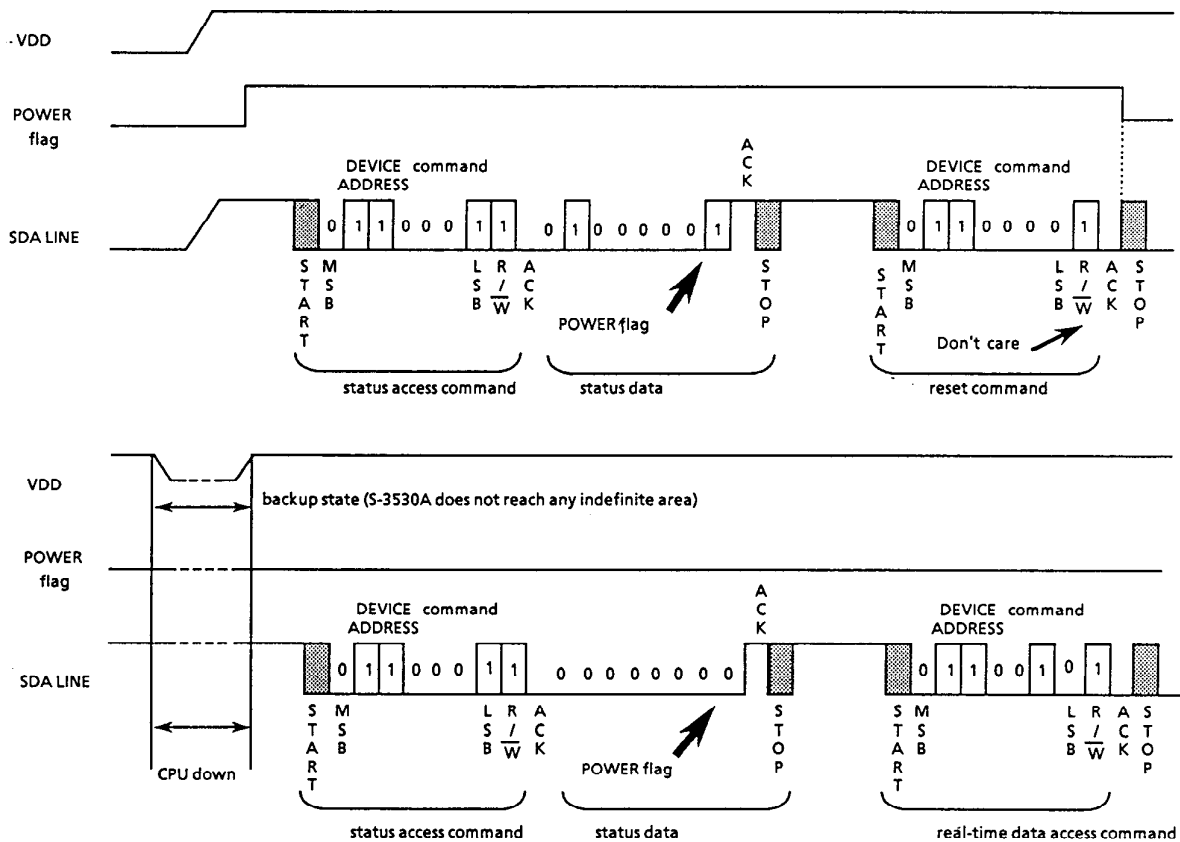

Figure 14 Initializing

4. Processing of none-existent data and end-of-month

When writing real-time data, validate it and treat any invalid data and end-of-month correction.

[None-existent data processing]

Table 3 None-existent data processing

Register	Normal data	Error data	Result
Year data	00 to 99	XA to XF, AX to FX	00
Month data	01 to 12	00, 13 to 19, XA to XF	01
Day data	01 to 31	00, 32 to 39, XA to XF	01
Day of week data	0 to 6	7	0
Hour data (24-hour)	0 to 23	24 to 29, 3X, XA to XF	00
(*) (12-hour)	0 to 11	12 to 19, XA to XF	00
Minute data	00 to 59	60 to 79, XA to XF	00
Second data (**)	00 to 59	60 to 79, XA to XF	00

(*) For 12-hour expression, write the AM/PM flag. The AM/PM flag is ignored in 24-hour expression, but "0" for 0 to 11 o'clock and "1" for 12 to 23 o'clock are read in a read operation.

(**) None-existent data processing for second data is performed by a carry pulse one second after the end of writing. At this point, the carry pulse is sent to the minute

[End-of-month correction]

Any none-existent day is corrected to the first day of the next month. For example, February 30 is changed to March 1. Leap-year correction is also performed here.

5. Interrupt

There are different five output formats from the $\overline{\text{INT1}}$ and $\overline{\text{INT2}}$ terminals, which are chosen by the INTxAE, INTxME and INTxFE bits of the status register (x: 1 or 2).

(1) Alarm interrupt output

Alarm interrupt is enabled by setting hour and minute data to the INT1 register (or INT2 register) and turning the status register's INT1AE to "1" and INT1ME and INT1FE to "0" (or INT2AE to "1" and INT2ME and INT2FE to "0").

When set hour data is met, low is output from the $\overline{\text{INT1}}$ terminal (or $\overline{\text{INT2}}$ terminal). Since the output is held, rewrite INT1AE (or INT2AE) of the status register to "0" through serial communication to turn the output to high (OFF state).

(2) Selected frequency steady interrupt output

When you set frequency/duty data to the INT1 register (or INT2 register) and turn the status register's INT1ME to "0" and INT1FE to "1" (or INT2ME to "0" and INT2FE to "1"), clock set at the INTx register is output from the $\overline{\text{INT1}}$ terminal (or $\overline{\text{INT2}}$ terminal).

(3) Per-minute edge interrupt output

When a first minute carry is performed after the status register's INT1ME is set with "1" and INT1FE with "0" (or INT2ME with "0" and INT2FE with "1"), low is output from the $\overline{\text{INT1}}$ terminal (or $\overline{\text{INT2}}$ terminal). Since the output is held, rewrite INT1AE, INT1ME and INT1FE (or INT2AE, INT2ME and INT2FE) of the status register to "0" through serial communication to turn the output to high (OFF state).

(4) Per-minute steady interrupt output

When a first carry is performed after the status register's INT1ME and INT1FE are set with "1" (or INT2ME and INT2FE with "1"), clock is output from the $\overline{\text{INT1}}$ terminal (or $\overline{\text{INT2}}$ terminal) with a period of one minute (50% duty)

Note 1 : If changing an output mode, give care to the state of the INT1 and INT2 registers and output.

Note 2 : If per-minute edge interrupt output or per-minute steady interrupt output is chosen, the INT1 and INT2 registers have no meaning.

Table 4 Interrupt description

NO.	INT1AE	INT1ME	INT1FE	Description
0	0	0	0	$\overline{\text{INT1}}$ terminal output disabled (No interrupt output)
1	*	0	1	Selected frequency steady interrupt output from the $\overline{\text{INT1}}$ terminal
2	*	1	0	Per-minute edge interrupt output from the $\overline{\text{INT1}}$ terminal
3	*	1	1	Per-minute steady interrupt output from $\overline{\text{INT1}}$ terminal
4	1	0	0	Per-minute alarm interrupt output from $\overline{\text{INT1}}$ terminal
NO.	INT2AE	INT2ME	INT2FE	Description
5	0	0	0	$\overline{\text{INT2}}$ terminal output disabled (No interrupt output)
6	*	0	1	Selected frequency steady interrupt output from the $\overline{\text{INT2}}$ terminal
7	*	1	0	Per-minute edge interrupt output from the $\overline{\text{INT2}}$ terminal
8	*	1	1	Per-minute steady interrupt output from $\overline{\text{INT2}}$ terminal
9	1	0	0	Per-minute alarm interrupt output from $\overline{\text{INT2}}$ terminal

Note * : Don't care.

(1) Alarm interrupt output

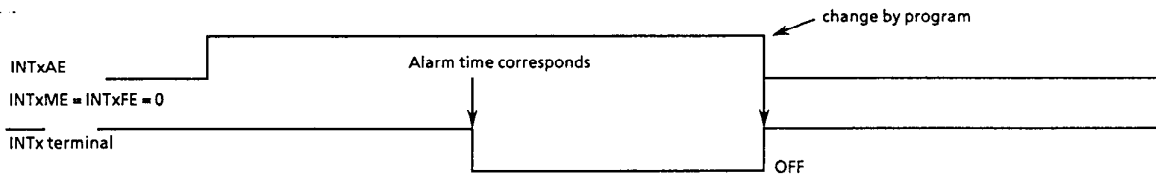

(2) Selected frequency steady interrupt output

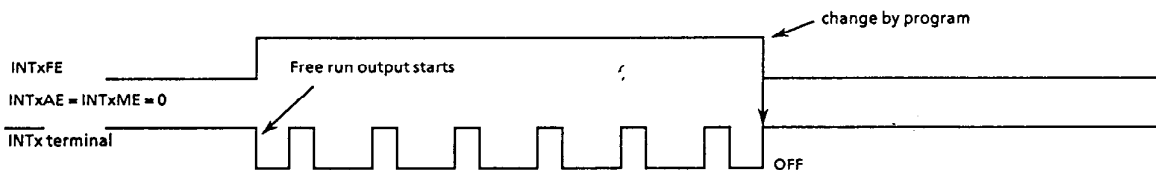

(3) Per-minute edge interrupt output

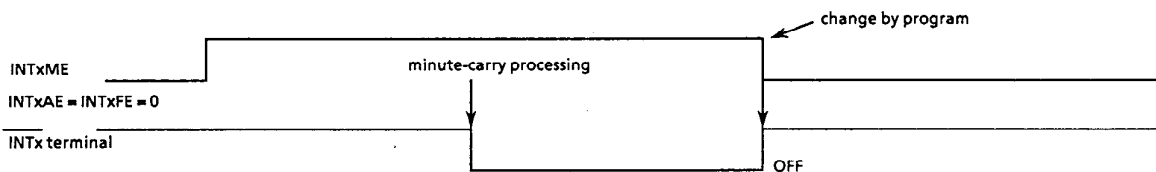

(4) Per-minute steady interrupt output

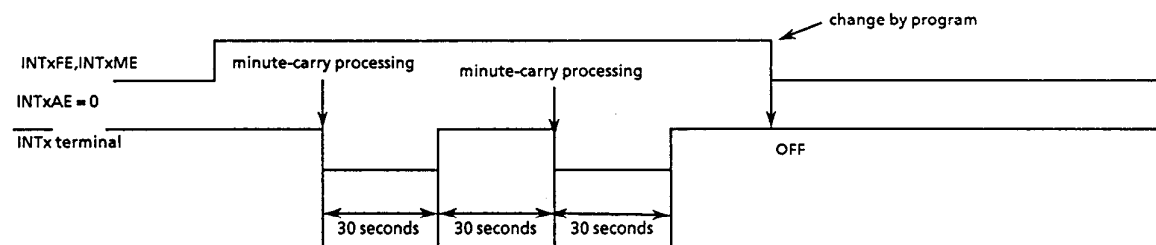

(5) During power-on detecting circuit operation

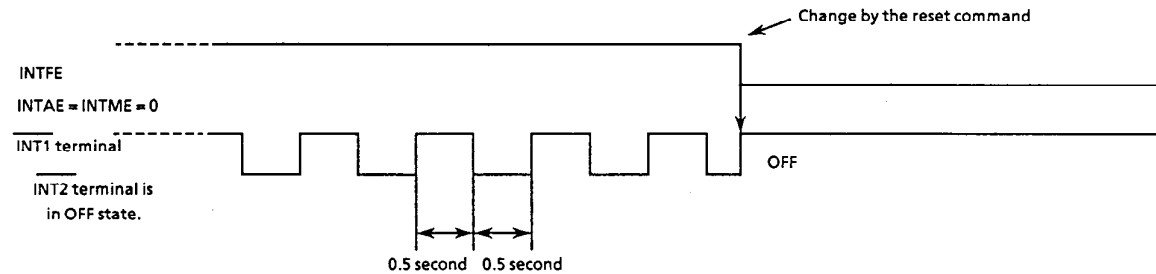

Figure 15 Output mode

6. Power voltage detecting circuit

S-3530 has an internal power voltage detecting circuit. This circuit gives sampling movement for only 15.6msec. once a second.

If the power voltage decreases below the detected voltage (V_{DET}), sampling movement stops. Only when subsequent communication is of the status read command, the output of the latch circuit is transferred to the shift register and the sampling movement is resumed.

Decrease in power voltage can be monitored by reading the POWER flag.

That is to say, once decrease in power voltage is detected, any detecting operation is not performed and "H" is held unless you perform initialization or send the status read command.

[Note]

When power voltage is increased and the first read operation is performed after decrease in power voltage occurs and the latch circuit latches "H", "1" can be read on the POWER flag. However, if the next read operation is performed after the sampling of the detecting circuit, the POWER flag is reset since sampling is subsequently allowed. See the timing diagram below.

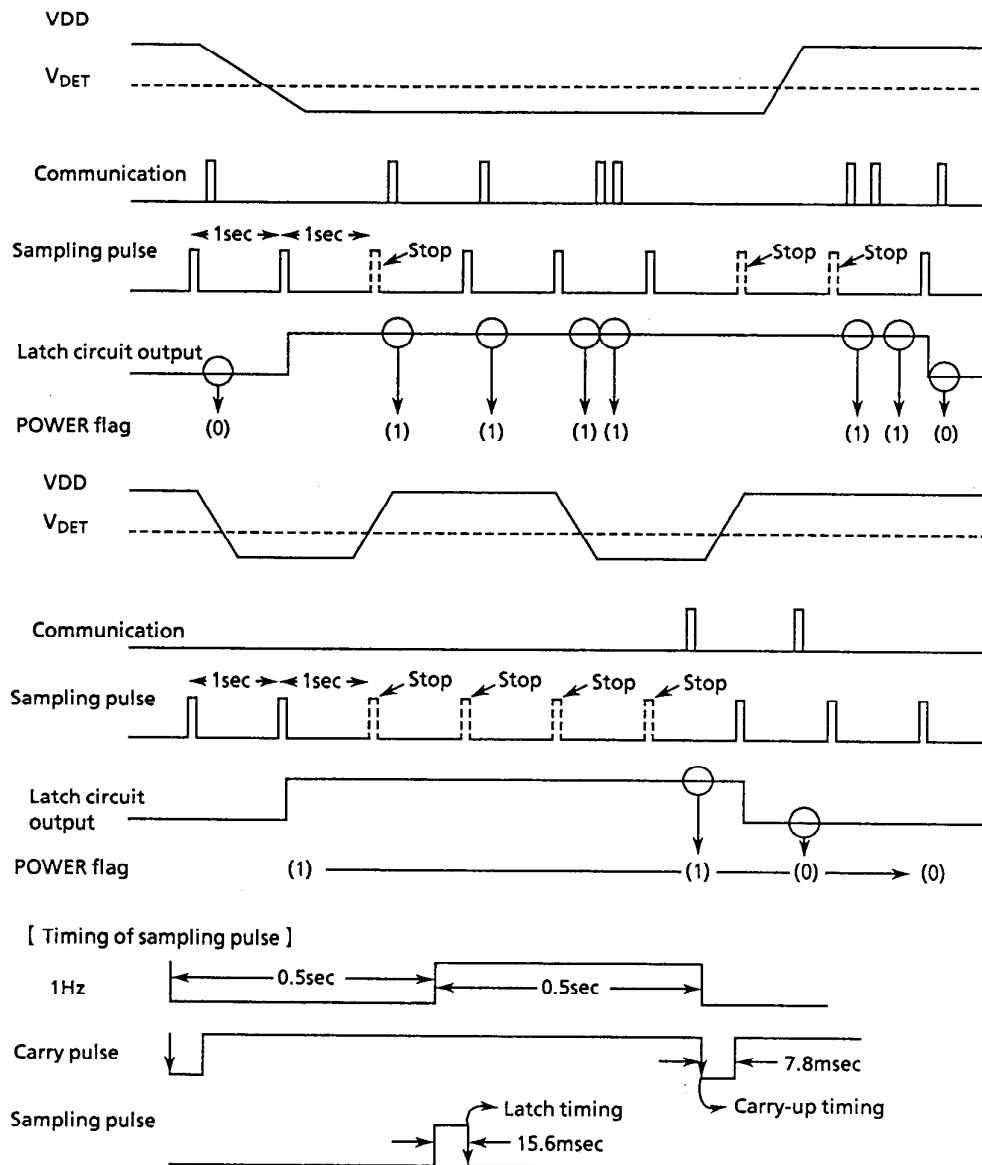
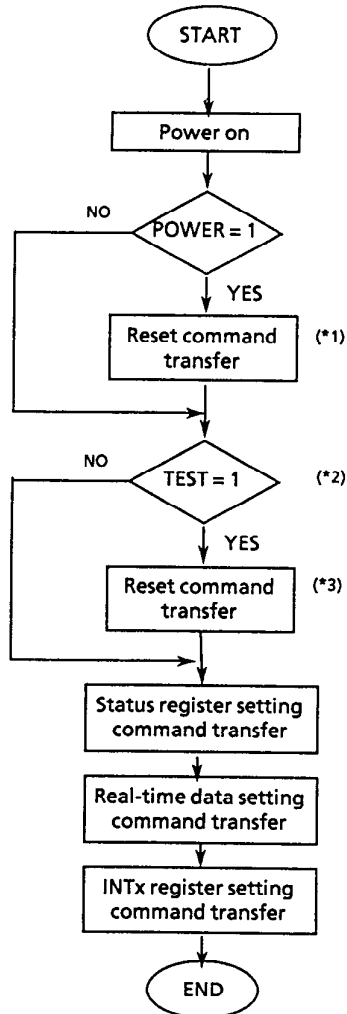

Figure 16 Timing of the power voltage detecting circuit

7.Example of software treatment

(1) Initialization flow at power-on



(*1) If S-3530 is back-up and power is turned on only on the CPU side, the reset command does not need transferring.

(*2) If conditions are no good (e.g., noise) and probable changes in commands occurs via serial communications, it is recommended to make sure the TEST flag.

(*3) The test ending command may be used alternately

Figure 17 Initialization flow

■ Samples of Applied Circuits

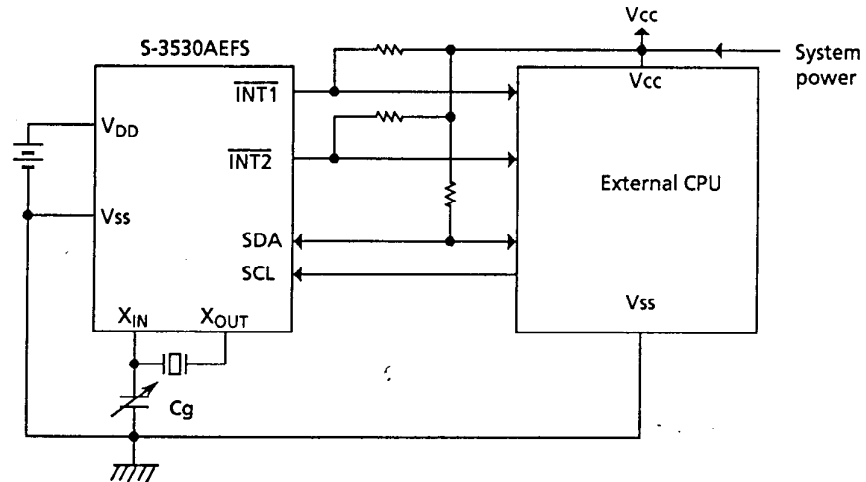

Due to the I/O terminal with no protective diode on the VDD side, the relation of $VCC \geq VDD$ has no problem. But give great care to the standard.

Make communications after the system power is turned on and a stable state is obtained.

Figure 18 Applied circuit 1

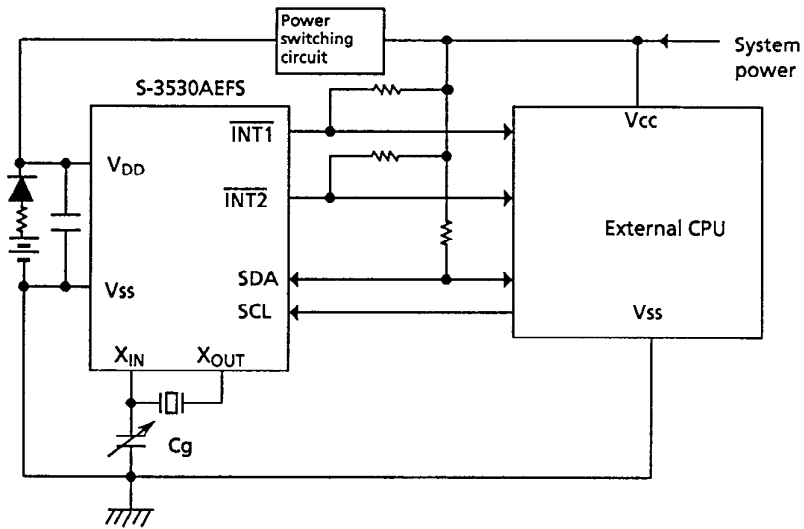

Make communications after the system power is turned on and a stable state is obtained.

Figure 19 Applied circuit 2

■ Dimensional Outline Diagram (Unit: mm)

Eight-pin SSOP

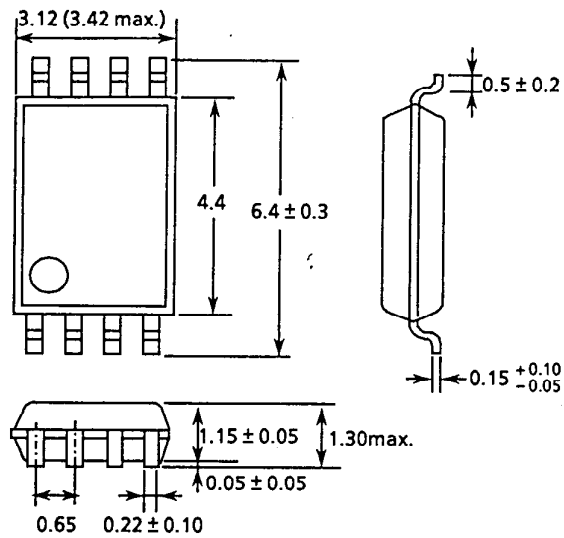
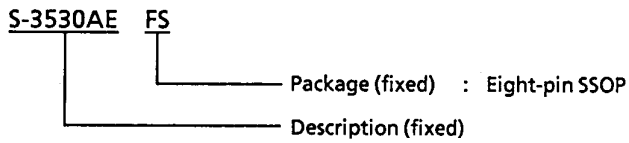

Figure 20 Dimensional outline diagram

■ Order Specification



■ Adjustment of Oscillating Frequency

1. Configuration of the oscillating circuit

Since crystal oscillation is sensitive to external noises (clock accuracy is affected), the following measures must be taken in configuring the oscillating circuit:

- (1) S-3530A, crystal oscillator and external capacitor (C_g) are placed as close to each other as possible.
- (2) Make high the insulation resistance between terminals and the board between XIN and XOUT.
- (3) Do not place any signal or power lines close to the oscillating circuit.

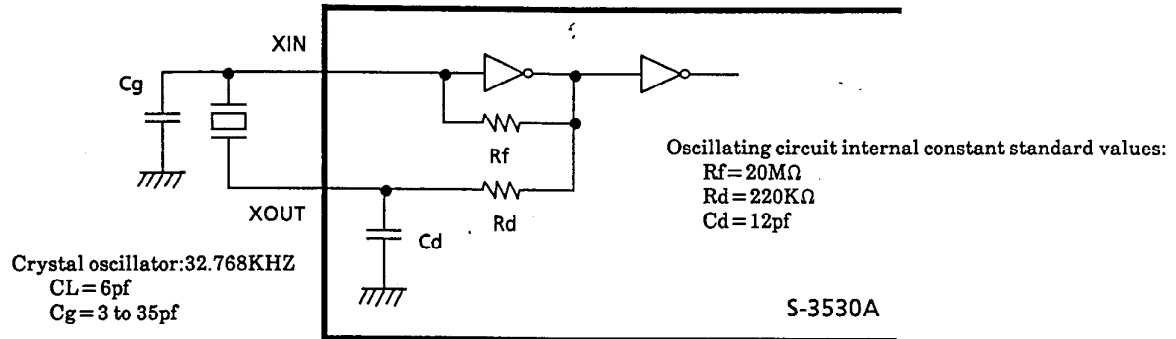

Figure 21 Connection diagram

2. Measurement of oscillating frequencies

When power is turned on, S-3530A has the internal power-on detecting circuit operating and outputs a signal of 1HZ from the $\overline{\text{INT1}}$ terminal to select the crystal oscillator and optimize the C_g value. Turn power on and measure the signal with a frequency counter following the circuit configuration shown in Figure 22. Refer to 11 and 14 pages in this document for further information.

(*) If the error range is $\pm 1\text{ppm}$ in relation to 1HZ, time is shifted by approximately 2.6 seconds a month:

$$10^{-6} (1\text{ppm}) \times 60 \text{ seconds} \times 60 \text{ minutes} \times 24 \text{ hours} \times 30 \text{ days} = 2.592 \text{ seconds}$$

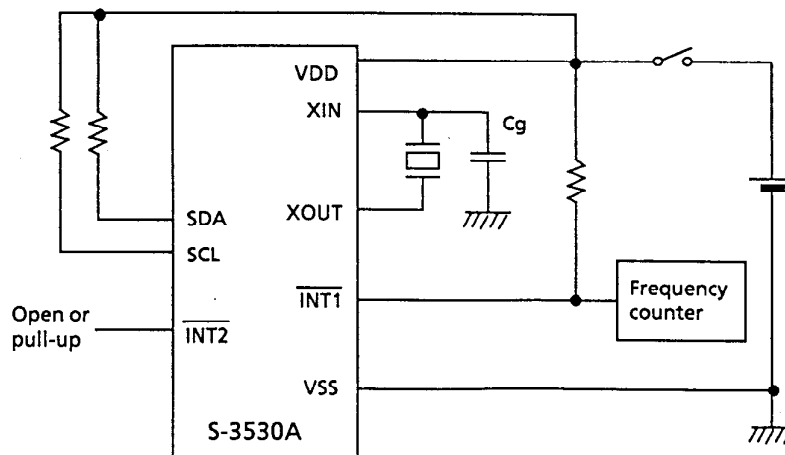

Note 1: Use a high-accuracy frequency counter (1ppm order).

Note 2: Since the 1HZ signal continues to be output, you must send the reset command in normal operation.

Note 3: Determine C_g with its frequency slow/fast range property referred.

Figure 22 Connection diagram

3. Adjustment of oscillating frequencies

Matching of a crystal oscillator with the nominal frequency must be performed with suspended capacity on the board included. Select a crystal oscillator and optimize the Cg value in accordance with the flow chart below.

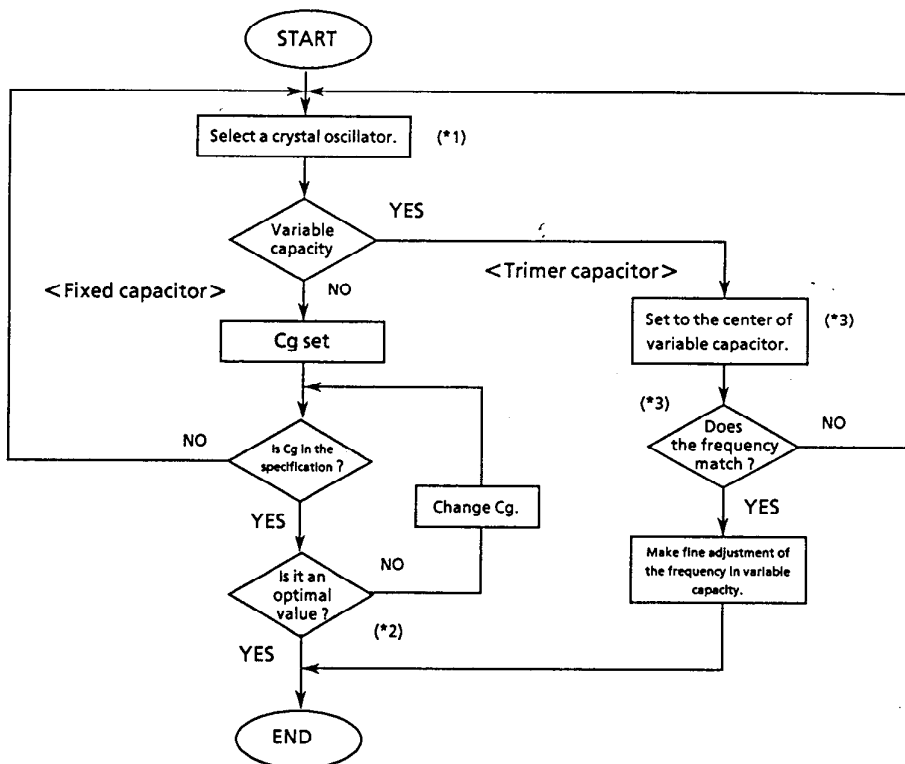

- (*1) For making matching adjustment of the IC with a crystal, contact an appropriate crystal maker to determine the CL value (load capacity) and RI value (equivalent serial capacity). The CL value = 6pf and RI value = 30KΩ TYP. are recommended values.
- (*2) Cg value selection must be performed on the actual PCB since suspended capacity affects it. Select the Cg value in a range from 3pf to 35pf. If the frequency does not match, change the CL value of the crystal.
- (*3) Adjust the rotation angle of the variable capacity so that the capacity value is somewhat smaller than the center, and confirm the oscillating frequency and the center value of the variable capacity. This is done in order to make the capacity of the center value smaller than one half of the actual capacity value because a smaller capacity value makes a greater quantity of changes in a frequency. If the frequency does not match, change the CL value of the crystal.

Note 1 : Oscillating frequencies are changed by ambient temperature and power voltage. Refer to property samples.

Note 2 : The 32KHZ crystal oscillator operates slower at higher or lower ambient temperature than 20 to 25°C. Therefore, it is recommended to adjust or set the oscillator to operate somewhat faster at normal temperature.

■ Absolute Maximum Ratings

Table 5 Absolute maximum ratings

Item	Symbol	Rating	Unit	Applicable terminal, conditions
Power voltage	VDD	- 0.3 to + 6.5	V	—
Input voltage	V _{IN}	- 0.3 to + 6.5	V	SCL,SDA
Output voltage	V _{OUT}	- 0.3 to + 6.5	V	SDA,INT1,INT2
Operating temperature	T _{opr}	- 40 to + 85	°C	VDD = 3.0V
Retention temperature	T _{stg}	- 55 to + 125	°C	—

■ Recommended Operating Conditions

Table 6 Recommended operating conditions

Item	Symbol	Condition	Min.	Typ.	Max.	Unit
Power voltage	VDD	—	1.7	3.0	5.5	V
Operating temperature	T _{opr}	—	- 20	+ 25	+ 70	°C

■ Oscillation Characteristics

Table 7 Oscillation characteristics

(T_a = 25°C, VDD = 3V, DS-VT-200 (crystal oscillator, CL = 6pF, 32,768HZ) manufactured by Seiko Electronic Part Co., Ltd.)

Item	Symbol	Condition	Min.	Typ.	Max.	Unit
Oscillation start voltage	V _{STA}	Within ten seconds	1.7	—	5.5	V
Oscillation start time	T _{STA}	—	—	—	1	SEC
IC-to-IC frequency diversity	δ _{IC}	—	- 10	—	+ 10	ppm
Frequency voltage diversity	δ _V	VDD = 1.7 to 5.5V	- 3	—	+ 3	ppm/V
Input capacity	C _g	Applied to the XIN terminal	3	—	35	pF
Output capacity	C _d	Applied to the XOUT terminal	—	12	—	pF

■ DC Electrical Characteristics

Table 8 DC characteristics (3V)

(Ta = 25°C, VDD = 3V, DS-VT-200 (crystal oscillator, CL = 6pF, 32,768HZ) manufactured by Seiko Electronic Part Co., Ltd.)

Item	Symbol	Condition	Min.	Typ.	Max.	Unit	Applicable terminal
Range of operating voltage	VDD	Ta = -20 to +70°C	1.7	3.0	5.5	V	—
Drain current 1	I _{DD1}	During no communications	—	0.7	1.5	V	—
Drain current 2	I _{DD2}	During communications (SCL = 100KHZ)	—	12	20	μA	—
Input leak current 1	I _{ILL1}	V _{IN} = VDD	-0.5	—	0.5	μA	SCL, SDA
Input leak current 2	I _{ILL2}	V _{IN} = VSS	-0.5	—	0.5	μA	SCL, SDA
Output leak current1	I _{OZH}	V _{OUT} = VDD	-0.5	—	0.5	μA	$\overline{\text{INT1, INT2}}$ SDA
Output leak current2	I _{OZL}	V _{OUT} = VSS	-0.5	—	0.5	μA	$\overline{\text{INT1, INT2}}$ SDA
Input voltage 1	V _{IH}	—	0.8xVDD	—	—	V	SDA, SCL
Input voltage 2	V _{IL}	—	—	—	0.2xVDD	V	SDA, SCL
Output current 1	I _{OL1}	V _{OUT} = 0.4V	1.5	2.5	—	mA	$\overline{\text{INT1, INT2}}$
Output current 2	I _{OL2}	V _{OUT} = 0.4V	5	10	—	mA	SDA
Power voltage detecting voltage 1	V _{DET1}	Ta = +25°C	1.8	2.0	2.2	V	—
Power voltage detecting voltage 2	V _{DET2}	Ta = -20 to +70°C	1.72	—	2.3	V	—

Table 9 DC characteristics (5V)

($T_a = 25^\circ\text{C}$, $V_{DD} = 3\text{V}$, DS-VT-200 (crystal oscillator, $CL = 6\text{pF}$, $32,768\text{HZ}$) manufactured by Seiko Electronic Part Co., Ltd.)

Item	Symbol	Condition	Min.	Typ.	Max.	Unit	Applicable terminal
Range of operating voltage	VDD	$T_a = -20$ to $+70^\circ\text{C}$	1.7	3.0	5.5	V	—
Drain current 1	I_{DD1}	During no communications	—	1.6	3.0	V	—
Drain current 2	I_{DD2}	During communications (SCL = 100KHZ)	—	26	40	μA	—
Input leak current 1	I_{ILL1}	$V_{IN} = V_{DD}$	-0.5	—	0.5	μA	SCL, SDA
Input leak current 2	I_{ILL2}	$V_{IN} = V_{SS}$	-0.5	—	0.5	μA	SCL, SDA
Output leak current1	I_{OZH}	$V_{OUT} = V_{DD}$	-0.5	—	0.5	μA	$\overline{\text{INT1}}, \overline{\text{INT2}}$ SDA
Output leak current2	I_{OZL}	$V_{OUT} = V_{SS}$	-0.5	—	0.5	μA	$\overline{\text{INT1}}, \overline{\text{INT2}}$ SDA
Input voltage 1	V_{IH}	—	$0.8 \times V_{DD}$	—	—	V	SDA, SCL
Input voltage 2	V_{IL}	—	—	—	$0.2 \times V_{DD}$	V	SDA, SCL
Output current 1	I_{OL1}	$V_{OUT} = 0.4\text{V}$	2.0	3.5	—	mA	$\overline{\text{INT1}}, \overline{\text{INT2}}$
Output current 2	I_{OL2}	$V_{OUT} = 0.4\text{V}$	6	12	—	mA	SDA
Power voltage detecting voltage 1	V_{DET1}	$T_a = +25^\circ\text{C}$	1.8	2.0	2.2	V	—
Power voltage detecting voltage 2	V_{DET2}	$T_a = -20$ to $+70^\circ\text{C}$	1.72	—	2.3	V	—

■ AC Electrical Characteristics

Table 10 Measurement conditions

Input pulse voltage	0.1 × VDD to 0.9 × VDD
Input pulse rising/falling time	20ns
Output judgment voltage	0.5 × VDD
Output load	100pF + pull-up resistance 1.0kΩ

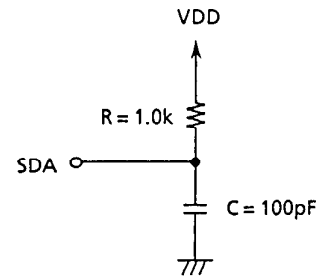

Figure Output load circuit

Table 11 AC properties

Item	Symbol	VDD = 1.7V to 5.5V			Unit
		Min.	Typ.	Max.	
SCL clock frequency	f _{SCL}	0	—	100	kHz
SCL clock "L" time	t _{LOW}	4.7	—	—	μs
SCL clock "H" time	t _{HIGH}	4.0	—	—	μs
SDA output delay time	t _{PD}	—	—	3.5	μs
Start condition setup time	t _{SU.STA}	4.7	—	—	μs
Start condition holding time	t _{HD.STA}	4.0	—	—	μs
Data input setup time	t _{SU.DAT}	250	—	—	ns
Data input holding time	t _{HD.DAT}	150	—	—	ns
Stop condition setup time	t _{SU.STO}	4.7	—	—	μs
SCL-SDA rising time	t _R	—	—	1.0	μs
SCL-SDA falling time	t _F	—	—	0.3	μs
Bus release time	t _{BUF}	4.7	—	—	μs
Noise suppression time	t _I	—	—	100	ns

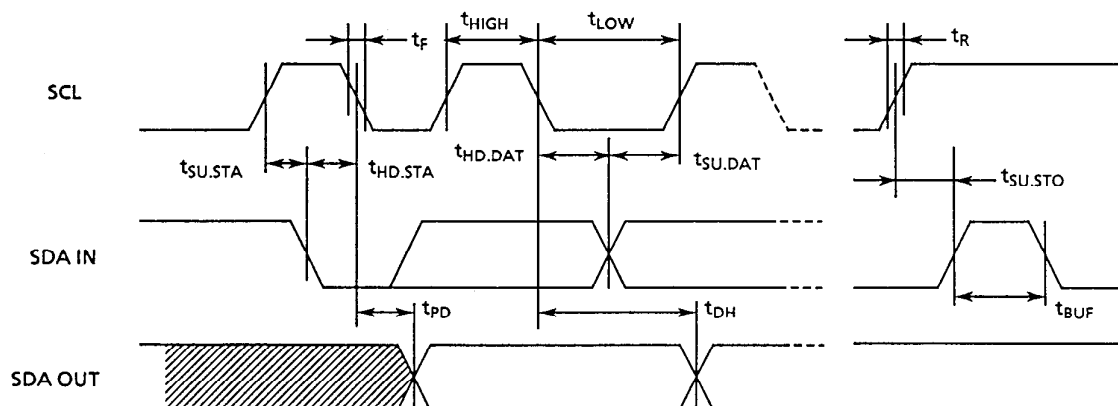
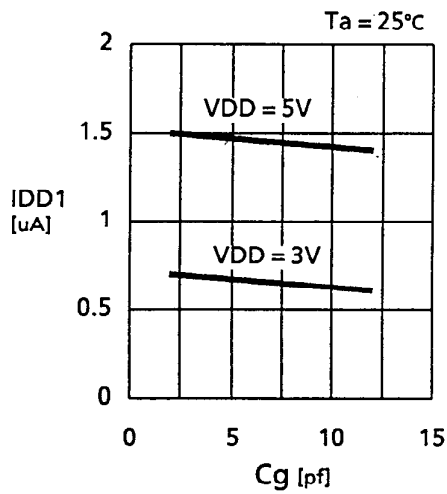

Figure 22 Bus timing

■ Sample of Characteristics (Reference values)

(1) Standby current versus C_g



(2) Standby current versus VDD

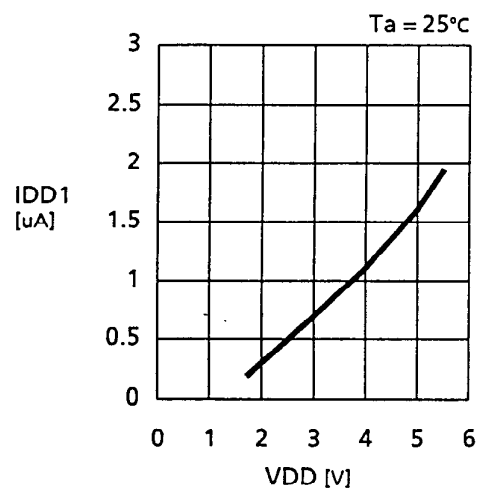

(3) Operating drain current versus Input clock

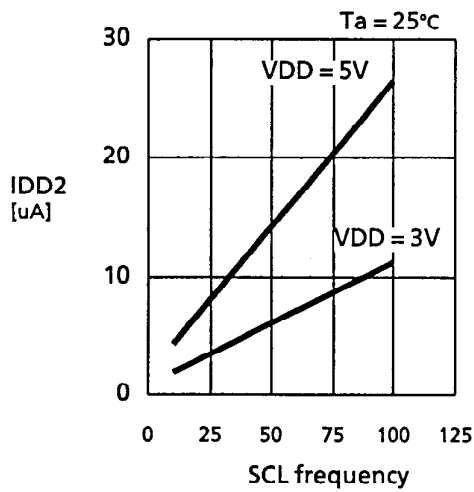

(4) Standby current versus temperature

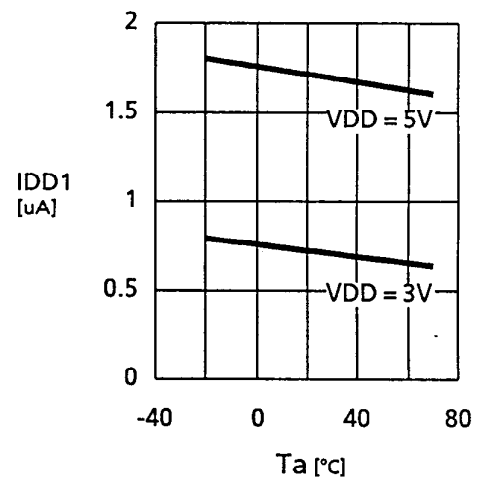

(5) Oscillating frequency versus C_g

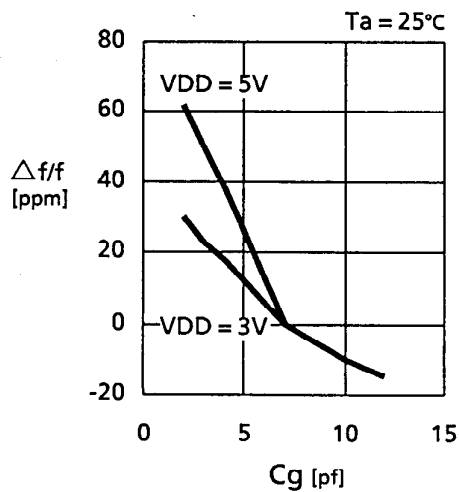

(6) Oscillating frequency versus VDD

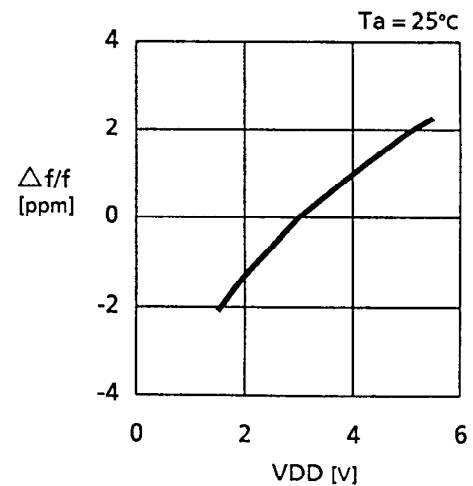

(7) Oscillating frequency versus temperature

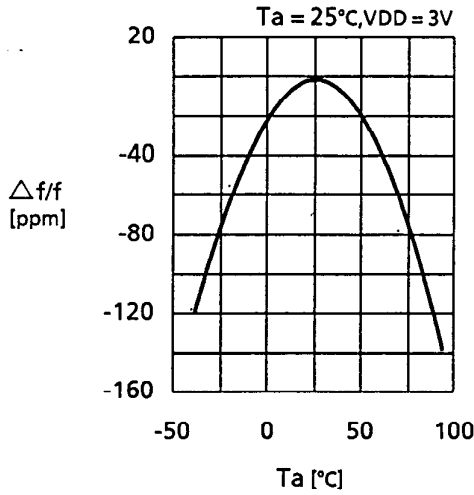

(8) Oscillation start time versus C_g

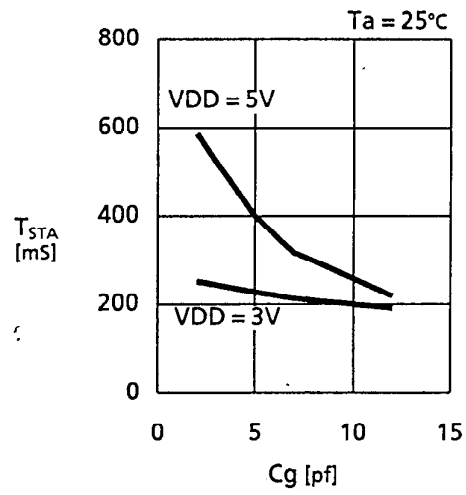

(9) Output current 1 (VDS versus I_{DS})

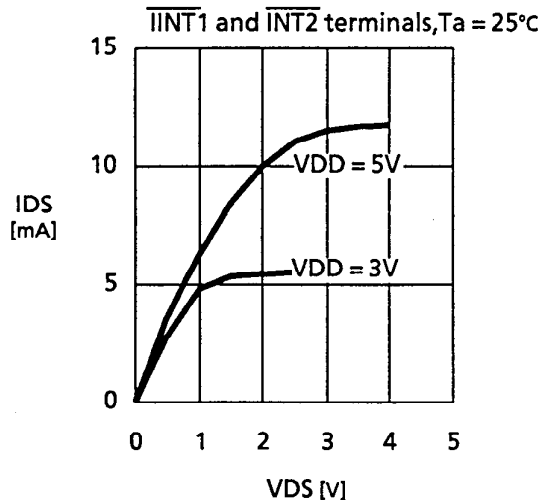

(10) Output current 2 (VDS versus I_{DS})

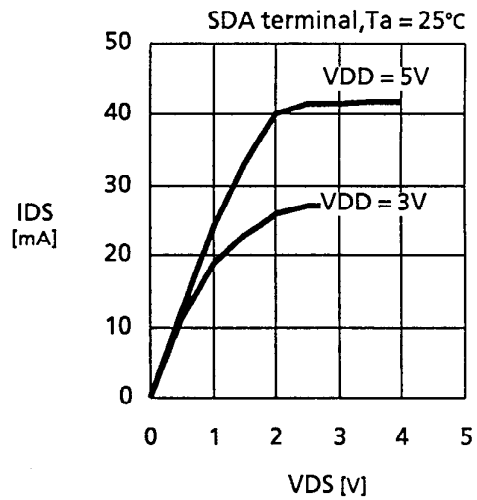

Purchase of I²C components of Seiko Instruments Inc. conveys a license under the Philips I²C Patent Rights to use these components in an I²C system, provided that the system conforms to the I²C Standard Specification as defined by Philips.

Please note that any product or system incorporating this IC may infringe upon the Philips I²C Bus Patent Rights depending upon its configuration.

In the event that such product or system incorporating the I²C Bus infringes upon the Philips Patent Rights, Seiko Instruments Inc. shall not bear any responsibility for any matters with regard to and arising from such patent infringement.

- Information in this document is subject to change without notice. Seiko Installments, Inc. (SII) reserves the right to make changes in design or components as progress in engineering and manufacturing may warrant.
- SII assumes no responsibility for any problems caused by the drawings or diagrams covered by proprietaries of third parties in this document. The samples of applied circuits are provided for representing typical applications of the product and assures no mass production.
- If products described in this document correspond to any strategic material (or service) specified in the Foreign Trade Control Law, the export permission of the Japanese government based on the law is required.
- Products described in this document may not be used as a part of any device or equipment which affects a human body, including health equipment, medical installment and emergency equipment.
- No part of this document may not be reproduced for any other purposes without the prior written permission of SII.