

# MC68HC912BD32

Advance Information

Rev 1.0

October 23, 2000

**Freescale Semiconductor, Inc.**

**Freescale Semiconductor, Inc.**

**For More Information On This Product,  
Go to: [www.freescale.com](http://www.freescale.com)**

List of Sections

List of Sections . . . . . 3

Table of Contents. . . . . 1

General Description . . . . . 5

Central Processing Unit. . . . . 11

Pinout and Signal Descriptions. . . . . 17

Registers . . . . . 33

Operating Modes and Resource Mapping. . . . . 43

Bus Control and Input/Output . . . . . 55

Flash EEPROM. . . . . 65

EEPROM. . . . . 81

Resets and Interrupts. . . . . 89

Clocks. . . . . 97

Pulse Width Modulator . . . . . 109

Standard Timer Module. . . . . 127

Serial Interface. . . . . 143

Byteflight™ Module . . . . .	167
Analog to Digital Converter . . . . .	219
Development Support . . . . .	231
Preliminary Electrical Characteristics . . . . .	255
Literature Updates . . . . .	275
Glossary . . . . .	277

**Table of Contents**

List of Sections

Table of Contents

General Description    Contents .....5  
                                  Introduction .....5  
                                  Features .....6  
                                  Ordering Information .....8  
                                  MC68HC912BD32 Block Diagram .....9

Central Processing Unit    Contents .....11  
                                  Introduction .....11  
                                  Programming Model .....11  
                                  Data Types .....13  
                                  Addressing Modes .....13  
                                  Indexed Addressing Modes .....15  
                                  Opcodes and Operands .....16

Pinout and Signal Descriptions    Contents .....17  
                                  MC68HC912BD32 Rev 1.0 Pin Assignments .....17  
                                  Power Supply Pins .....19  
                                  Signal Descriptions .....20  
                                  Port Signals .....26  
                                  Port Pull-Up, Pull-Down and Reduced Drive .....31

Registers    Contents .....33  
                                  Introduction .....33

Operating Modes and Resource Mapping    Contents .....43  
                                  Introduction .....43  
                                  Operating Modes .....43  
                                  Background Debug Mode .....46  
                                  Internal Resource Mapping .....49  
                                  Memory Maps .....53

**Table of Contents**

Bus Control and Input/Output	Contents .....	.55
	Introduction .....	.55
	Detecting Access Type from External Signals .....	.55
	Registers .....	.56
Flash EEPROM	Contents .....	.65
	Introduction .....	.65
	Overview .....	.66
	Flash EEPROM Control Block .....	.66
	Flash EEPROM Array .....	.66
	Flash EEPROM Registers .....	.67
	Operation .....	.71
	Programming the Flash EEPROM .....	.74
	Erasing the Flash EEPROM .....	.76
	Program/Erase Protection Interlocks .....	.78
	Stop or Wait Mode .....	.78
	Test Mode .....	.79
EEPROM	Contents .....	.81
	Introduction .....	.81
	EEPROM Programmer's Model .....	.82
	EEPROM Control Registers .....	.83
Resets and Interrupts	Contents .....	.89
	Introduction .....	.89
	Exception Priority .....	.89
	Maskable interrupts .....	.90
	Interrupt Control and Priority Registers .....	.92
	Resets .....	.93
	Effects of Reset .....	.94
	Register Stacking .....	.96
Clocks	Contents .....	.97
	Introduction .....	.97
	Clock Selection and Generation .....	.97
	Slow Mode Divider .....	.100
	CGM Register Description .....	.100
	Clock Functions .....	.101
	Computer Operating Properly (COP) .....	.101

	Real-Time Interrupt .....	102
	Clock Monitor .....	102
	Clock Function Registers .....	103
	Clock Divider Chains .....	107
Pulse Width Modulator	Contents .....	109
	Introduction .....	109
	PWM Register Description .....	114
	PWM Boundary Cases .....	125
Standard Timer Module	Contents .....	127
	Introduction .....	127
	Timer Registers .....	129
	Timer Operation in Modes .....	142
Serial Interface	Contents .....	143
	Introduction .....	143
	Block diagram .....	144
	Serial Communication Interface (SCI) .....	144
	Serial Peripheral Interface (SPI) .....	155
	Port S .....	164
Byteflight™ Module	Contents .....	167
	Introduction .....	167
	Features .....	168
	External Pins .....	169
	Byteflight™ System .....	169
	Byteflight™ Protocol .....	171
	Functional Overview .....	176
	Low Power Modes .....	186
	Programmer's Model .....	189
	Initialization .....	216
	FIFO Usage .....	217
Analog to Digital Converter	Contents .....	219
	Introduction .....	219
	Functional Description .....	220
	ATD Registers .....	221
	ATD Mode Operation .....	230

**Table of Contents**

Development Support	Contents .....	231
	Introduction .....	231
	Instruction Queue .....	231
	Background Debug Mode .....	233
	Breakpoints .....	247
	Instruction Tagging .....	253
Preliminary Electrical Characteristics		
Literature Updates	Literature Distribution Centers .....	275
	Customer Focus Center .....	276
	Microcontroller Division's Web Site .....	276
Glossary		



# General Description

---

---

## Contents

Introduction .....	5
Features .....	6
Ordering Information .....	8
MC68HC912BD32 Block Diagram .....	9

---

---

## Introduction

The MC68HC912BD32 microcontroller unit (MCU) is a 16-bit device composed of standard on-chip peripherals including a 16-bit central processing unit (CPU12), 32K byte flash EEPROM, 1K byte RAM, 768 byte EEPROM, an asynchronous serial communications interface (SCI), a serial peripheral interface (SPI), an 8-channel timer and 16-bit pulse accumulator, a 10-bit analog-to-digital converter (ADC), a four-channel pulse-width modulator (PWM), and a Byteflight™ module. System resource mapping, clock generation, interrupt control and bus interfacing are managed by the Lite integration module (LIM). The MC68HC912BD32 has full 16-bit data paths throughout, however, the multiplexed external bus can operate in an 8-bit narrow mode so single 8-bit wide memory can be interfaced for lower cost systems.

---

---

### Features

- 16-Bit CPU12
  - Upward Compatible with M68HC11 Instruction Set
  - Interrupt Stacking and Programmer's Model Identical to M68HC11
  - 20-Bit ALU
  - Instruction Queue
  - Enhanced Indexed Addressing
  - Fuzzy Logic Instructions
- Multiplexed Bus
  - Single Chip or Expanded
  - 16/16 Wide or 16/8 Narrow Modes
- Memory
  - 32K byte Flash EEPROM with 2K byte Erase-Protected Boot Block
  - 768 byte EEPROM
  - 1K byte RAM with Single-Cycle Access for Aligned or Misaligned Read/Write
- 8-Channel, 10-Bit Analog-to-Digital Converter
- 8-Channel Timer
  - Each Channel Fully Configurable as Either Input Capture or Output Compare
  - Simple PWM Mode
  - Modulo Reset of Timer Counter
- 16-Bit Pulse Accumulator
  - External Event Counting
  - Gated Time Accumulation

- Pulse-Width Modulator
  - 8-Bit, 4-Channel or 16-Bit, 2-Channel
  - Separate Control for Each Pulse Width and Duty Cycle
  - Programmable Center-Aligned or Left-Aligned Outputs
- Serial Interfaces
  - Asynchronous Serial Communications Interface (SCI)
  - Synchronous Serial Peripheral Interface (SPI)
- Byteflight™ Module
  - Modular Architecture
  - Implementation of the BMW Byteflight™ protocol
  - Double buffered receive storage systems
  - 16 Message Buffers in total
  - Programmable Message Buffer Configuration (transmit, receive, FIFO)
  - Receive FIFO for bus monitoring with programmable acceptance filter
  - 10 maskable interrupt sources, generating four CPU interrupt vectors
  - Programmable bus master function
  - Programmable wake-up function
  - Low power sleep mode
  - Separate clock system, synchronization to HC12 bus system
- COP Watchdog Timer, Clock Monitor, and Periodic Interrupt Timer
- Features 80-Pin QFP Package
  - Up to 50 General-Purpose I/O Lines
  - 4.75V–5.25V Operation at 10 MHz
- Single-Wire Background Debug™ Mode (BDM)
- On-Chip Hardware Breakpoints

Ordering Information

The MC68HC912BD32 is packaged in 80-pin quad flat pack (QFP) packaging and is shipped in two-piece sample packs, 84-piece trays, or 420-piece bricks. Operating temperature range and voltage requirements are specified when ordering the MC68HC912BD32 device. Refer to [Table 1](#) for part numbers.

**Table 1 MC68HC912BD32 Device Ordering Information**

Order Number	Temperature		Voltage	Frequency	Package
	Range	Designator			
MC68HC912BD32FU10	0 to +70 °C		4.75V–5.25V	10 MHz	80-Pin QFP Single Tray 84 Pcs
MC68HC912BD32CFU10	–40 to +85 °C	C			

**NOTE:** This part is also available in 2-piece sample packs and 420-piece bricks.

Evaluation boards, assemblers, compilers, and debuggers are available from Motorola and from third-party suppliers. An up-to-date list of products that support the M68HC12 family of microcontrollers can be found on the World Wide Web at the following URL:

<http://www.mcu.motps.com>

Documents to assist in product selection are available from the Motorola Literature Distribution Center or your local Motorola Sales Office:

AMCU Device Selection Guide (SG166/D)

AMCU Software and Development Tool Selector Guide (SG176/D)

MC68HC912BD32 Block Diagram

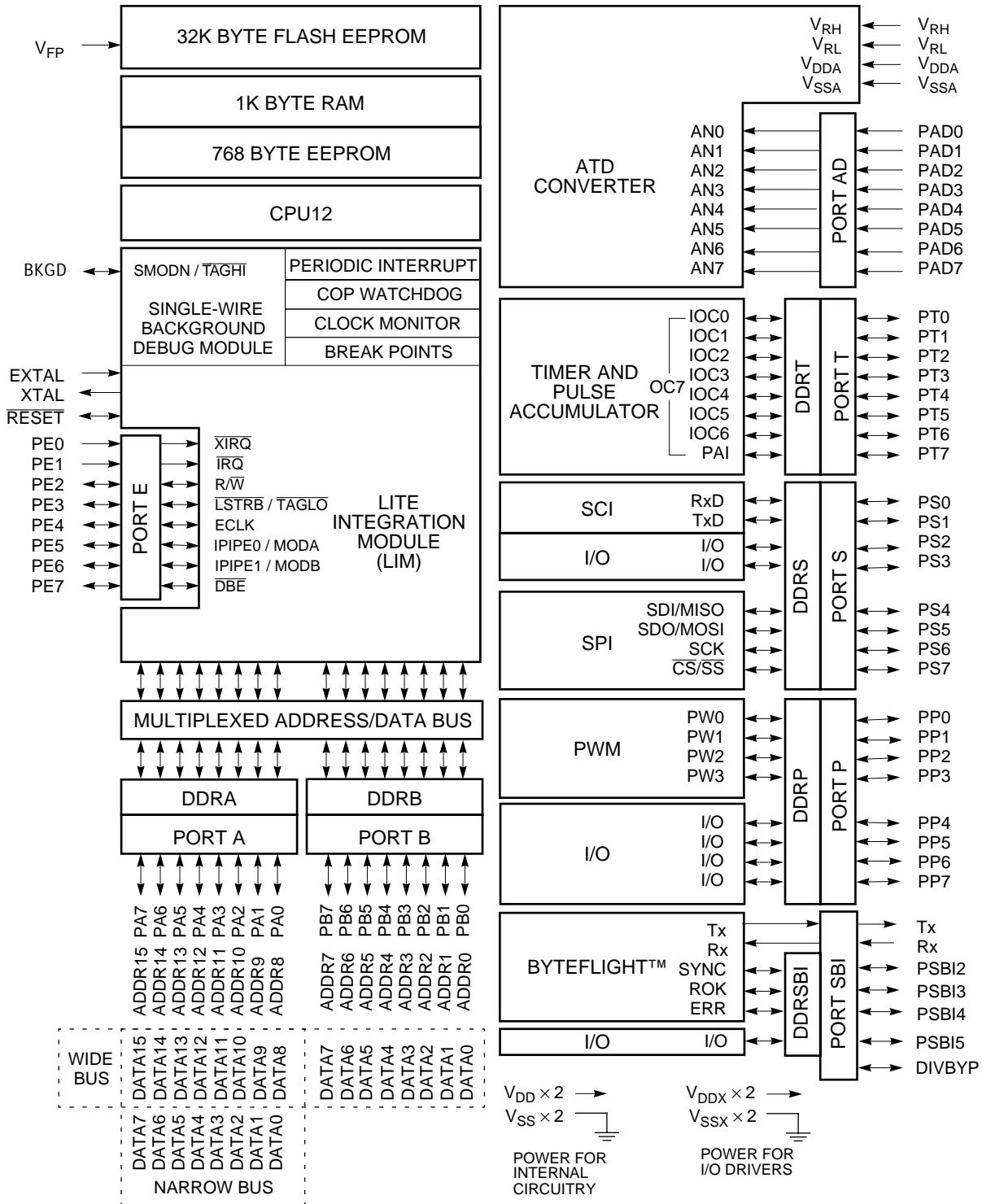

Figure 1 MC68HC912BD32 Block Diagram



# Central Processing Unit

---

---

## Contents

Introduction . . . . .	11
Programming Model . . . . .	11
Data Types . . . . .	13
Addressing Modes . . . . .	13
Indexed Addressing Modes . . . . .	15
Opcodes and Operands . . . . .	16

---

---

## Introduction

The CPU12 is a high-speed, 16-bit processing unit. It has full 16-bit data paths and wider internal registers (up to 20 bits) for high-speed extended math instructions. The instruction set is a proper superset of the M68HC11 instruction set. The CPU12 allows instructions with odd byte counts, including many single-byte instructions. This provides efficient use of ROM space. An instruction queue buffers program information so the CPU always has immediate access to at least three bytes of machine code at the start of every instruction. The CPU12 also offers an extensive set of indexed addressing capabilities.

---

---

## Programming Model

CPU12 registers are an integral part of the CPU and are not addressed as if they were memory locations.

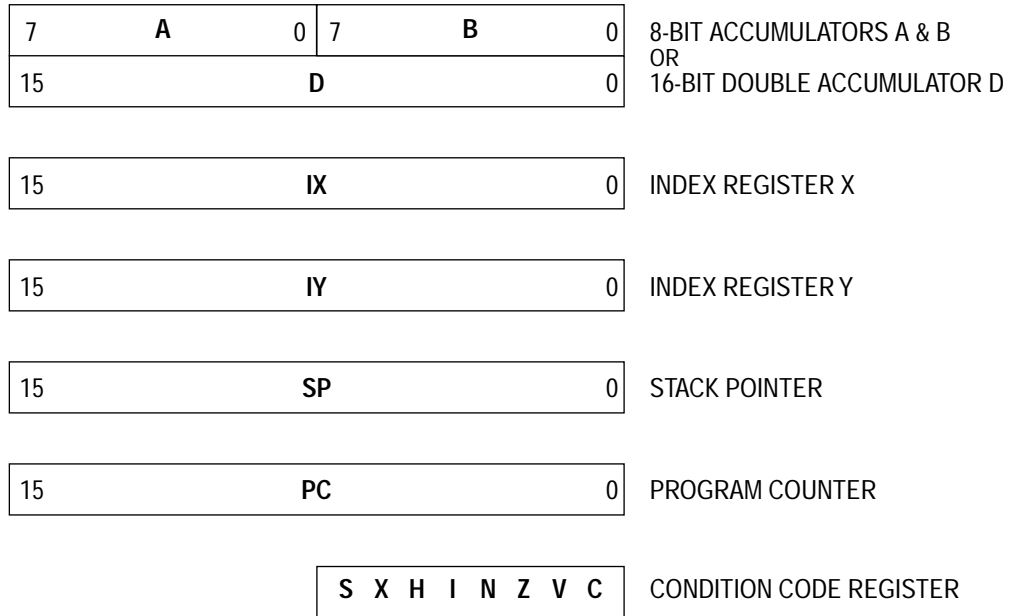

Figure 2 Programming Model

**Accumulators** A and B are general-purpose 8-bit accumulators used to hold operands and results of arithmetic calculations or data manipulations. Some instructions treat the combination of these two 8-bit accumulators as a 16-bit double accumulator (accumulator D).

**Index registers** X and Y are used for indexed addressing mode. In the indexed addressing mode, the contents of a 16-bit index register are added to 5-bit, 9-bit, or 16-bit constants or the content of an accumulator to form the effective address of the operand to be used in the instruction.

**Stack pointer** (SP) points to the last stack location used. The CPU12 supports an automatic program stack that is used to save system context during subroutine calls and interrupts, and can also be used for temporary storage of data. The stack pointer can also be used in all indexed addressing modes.

**Program counter** is a 16-bit register that holds the address of the next instruction to be executed. The program counter can be used in all indexed addressing modes except autoincrement/decrement.



**Condition Code Register (CCR)** contains five status indicators, two interrupt masking bits, and a STOP disable bit. The five flags are half carry (H), negative (N), zero (Z), overflow (V), and carry/borrow (C). The half-carry flag is used only for BCD arithmetic operations. The N, Z, V, and C status bits allow for branching based on the results of a previous operation.

After a reset, the CPU fetches a vector from the appropriate address and begins executing instructions. The X and I interrupt mask bits are set to mask any interrupt requests. The S bit is also set to inhibit the STOP instruction.

---

---

## Data Types

The CPU12 supports the following data types:

- Bit data
- 8-bit and 16-bit signed and unsigned integers
- 16-bit unsigned fractions
- 16-bit addresses

A byte is eight bits wide and can be accessed at any byte location. A word is composed of two consecutive bytes with the most significant byte at the lower value address. There are no special requirements for alignment of instructions or operands.

---

---

## Addressing Modes

Addressing modes determine how the CPU accesses memory locations to be operated upon. The CPU12 includes all of the addressing modes of the M68HC11 CPU as well as several new forms of indexed addressing. [Table 2](#) is a summary of the available addressing modes.

Table 2 M68HC12 Addressing Mode Summary

Addressing Mode	Source Format	Abbreviation	Description
Inherent	<b>INST</b> (no externally supplied operands)	INH	Operands (if any) are in CPU registers
Immediate	<b>INST #opr8i</b> or <b>INST #opr16i</b>	IMM	Operand is included in instruction stream 8- or 16-bit size implied by context
Direct	<b>INST opr8a</b>	DIR	Operand is the lower 8-bits of an address in the range \$0000 – \$00FF
Extended	<b>INST opr16a</b>	EXT	Operand is a 16-bit address
Relative	<b>INST rel8</b> or <b>INST rel16</b>	REL	An 8-bit or 16-bit relative offset from the current pc is supplied in the instruction
Indexed (5-bit offset)	<b>INST oprx5,xysp</b>	IDX	5-bit signed constant offset from x, y, sp, or pc
Indexed (auto pre-decrement)	<b>INST oprx3,-xys</b>	IDX	Auto pre-decrement x, y, or sp by 1 ~ 8
Indexed (auto pre-increment)	<b>INST oprx3,+xys</b>	IDX	Auto pre-increment x, y, or sp by 1 ~ 8
Indexed (auto post-decrement)	<b>INST oprx3,xys-</b>	IDX	Auto post-decrement x, y, or sp by 1 ~ 8
Indexed (auto post-increment)	<b>INST oprx3,xys+</b>	IDX	Auto post-increment x, y, or sp by 1 ~ 8
Indexed (accumulator offset)	<b>INST abd,xysp</b>	IDX	Indexed with 8-bit (A or B) or 16-bit (D) accumulator offset from x, y, sp, or pc
Indexed (9-bit offset)	<b>INST oprx9,xysp</b>	IDX1	9-bit signed constant offset from x, y, sp, or pc (lower 8-bits of offset in one extension byte)
Indexed (16-bit offset)	<b>INST oprx16,xysp</b>	IDX2	16-bit constant offset from x, y, sp, or pc (16-bit offset in two extension bytes)
Indexed-Indirect (16-bit offset)	<b>INST [opr16,xysp]</b>	[IDX2]	Pointer to operand is found at... 16-bit constant offset from x, y, sp, or pc (16-bit offset in two extension bytes)
Indexed-Indirect (D accumulator offset)	<b>INST [D,xysp]</b>	[D,IDX]	Pointer to operand is found at... x, y, sp, or pc plus the value in D

## Indexed Addressing Modes

The CPU12 indexed modes reduce execution time and eliminate code size penalties for using the Y index register. CPU12 indexed addressing uses a postbyte plus zero, one, or two extension bytes after the instruction opcode. The postbyte and extensions do the following tasks:

- Specify which index register is used.
- Determine whether a value in an accumulator is used as an offset.
- Enable automatic pre- or post-increment or decrement
- Specify use of 5-bit, 9-bit, or 16-bit signed offsets.

**Table 3 Summary of Indexed Operations**

Postbyte Code (xb)	Source Code Syntax	Comments
rr0nnnnn	,r n,r -n,r	<b>5-bit constant offset</b> n = -16 to +15 rr can specify X, Y, SP, or PC
111rr0zs	n,r -n,r	<b>Constant offset</b> (9- or 16-bit signed) z=0 = 9-bit with sign in LSB of postbyte(s) 1 = 16-bit if z = s = 1, 16-bit offset indexed-indirect (see below) rr can specify X, Y, SP, or PC
111rr011	[n,r]	<b>16-bit offset indexed-indirect</b> rr can specify X, Y, SP, or PC
rr1pnnnn	n,-r n,+r n,r- n,r+	<b>Auto pre-decrement/increment or Auto post-decrement/increment;</b> p = pre-(0) or post-(1), n = -8 to -1, +1 to +8 rr can specify X, Y, or SP (PC not a valid choice)
111rr1aa	A,r B,r D,r	<b>Accumulator offset</b> (unsigned 8-bit or 16-bit) aa-00 = A 01 = B 10 = D (16-bit) 11 = see accumulator D offset indexed-indirect rr can specify X, Y, SP, or PC
111rr111	[D,r]	<b>Accumulator D offset indexed-indirect</b> rr can specify X, Y, SP, or PC

---

---

### Opcodes and Operands

The CPU12 uses 8-bit opcodes. Each opcode identifies a particular instruction and associated addressing mode to the CPU. Several opcodes are required to provide each instruction with a range of addressing capabilities.

Only 256 opcodes would be available if the range of values were restricted to the number that can be represented by 8-bit binary numbers. To expand the number of opcodes, a second page is added to the opcode map. Opcodes on the second page are preceded by an additional byte with the value \$18.

To provide additional addressing flexibility, opcodes can also be followed by a postbyte or extension bytes. Postbytes implement certain forms of indexed addressing, transfers, exchanges, and loop primitives. Extension bytes contain additional program information such as addresses, offsets, and immediate data.

# Pinout and Signal Descriptions

---

---

## Contents

MC68HC912BD32 Rev 1.0 Pin Assignments . . . . .	17
Power Supply Pins . . . . .	19
Signal Descriptions . . . . .	20
Port Signals. . . . .	26
Port Pull-Up, Pull-Down and Reduced Drive. . . . .	31

---

---

## MC68HC912BD32 Rev 1.0 Pin Assignments

The MC68HC912BD32 is available in a 80-pin quad flat pack (QFP). Most pins perform two or more functions, as described in the [Signal Descriptions](#). [Figure 3](#) shows pin assignments. Shaded pins are power and ground.

Pinout and Signal Descriptions

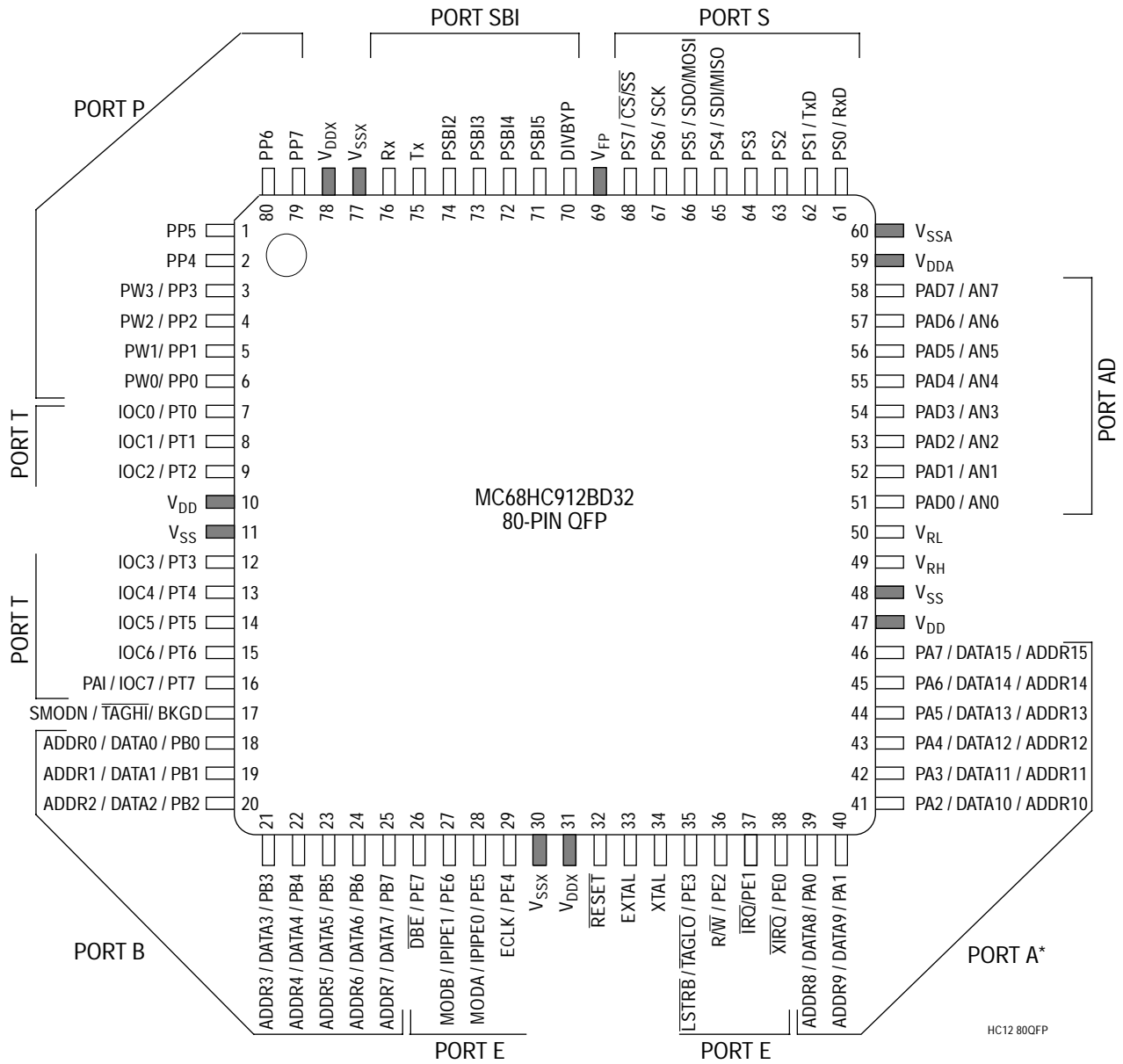

\* In narrow mode, high and low data bytes are multiplexed in alternate bus cycles on port A.

**Figure 3 Pin Assignments for MC68HC912BD32**

---



---

## Power Supply Pins

MC68HC912BD32 power and ground pins are described below and summarized in [Table 4](#).

Internal Power  
( $V_{DD}$ ) and Ground  
( $V_{SS}$ )

Power is supplied to the MCU through  $V_{DD}$  and  $V_{SS}$ . Because fast signal transitions place high, short-duration current demands on the power supply, use bypass capacitors with high-frequency characteristics and place them as close to the MCU as possible. Bypass requirements depend on how heavily the MCU pins are loaded.

External Power  
( $V_{DDX}$ ) and  
Ground ( $V_{SSX}$ )

External power and ground for I/O drivers. Because fast signal transitions place high, short-duration current demands on the power supply, use bypass capacitors with high-frequency characteristics and place them as close to the MCU as possible. Bypass requirements depend on how heavily the MCU pins are loaded.

$V_{DDA}$ ,  $V_{SSA}$

Provides operating voltage and ground for the analog-to-digital converter. This allows the supply voltage to the A/D to be bypassed independently.

Analog to Digital  
Reference  
Voltages ( $V_{RH}$ ,  $V_{RL}$ )

$V_{FP}$

Flash EEPROM programming voltage and supply voltage during normal operation.

Table 4 MC68HC912BD32 Power and Ground Connection Summary

Mnemonic	Pin Number	Description
V <sub>DD</sub>	10, 47	Internal power and ground.
V <sub>SS</sub>	11, 48	
V <sub>DDX</sub>	31, 78	External power and ground, supply to pin drivers.
V <sub>SSX</sub>	30, 77	
V <sub>DDA</sub>	59	Operating voltage and ground for the analog-to-digital converter, allows the supply voltage to the A/D to be bypassed independently.
V <sub>SSA</sub>	60	
V <sub>RH</sub>	49	Reference voltages for the analog-to-digital converter.
V <sub>RL</sub>	50	
V <sub>FP</sub>	69	Programming voltage for the Flash EEPROM and required supply for normal operation.

Signal Descriptions

Crystal Driver and External Clock Input (XTAL, EXTAL)

These pins provide the interface for either a crystal or a CMOS compatible clock to control the internal clock generator circuitry. Out of reset the frequency applied to EXTAL is four times the desired E-clock rate (in normal operation with DIVBYP=0; refer to [Clock Divider Bypass \(DIVBYP\)](#)) All the device clocks are derived from the EXTAL input frequency.

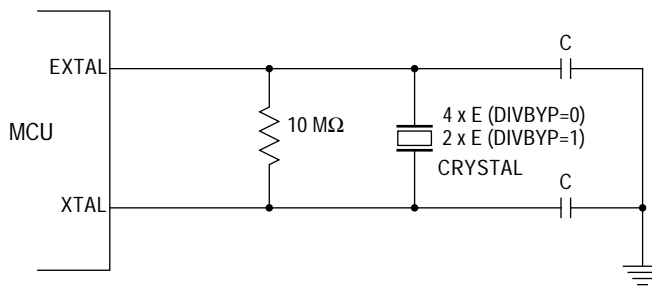
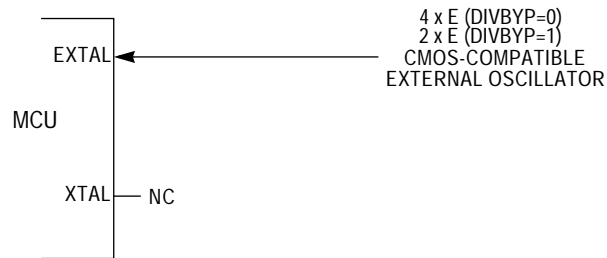

Figure 4 Common Crystal Connections





**Figure 5 External Oscillator Connections**

XTAL is the crystal output. The XTAL pin must be left unterminated when an external CMOS compatible clock input is connected to the EXTAL pin. The XTAL output is normally intended to drive only a crystal. The XTAL output can be buffered with a high-impedance buffer to drive the EXTAL input of another device.

In all cases take extra care in the circuit board layout around the oscillator pins. Load capacitances shown in the oscillator circuits include all stray layout capacitances. Refer to [Figure 4](#) and [Figure 5](#) for diagrams of oscillator circuits.

**E-Clock Output (ECLK)**

ECLK is the output connection for the internal bus clock and is used to demultiplex the address and data and is used as a timing reference. ECLK frequency is equal to 1/4 the crystal frequency out of reset (in normal operation with DIVBYP=0, refer to [Clock Divider Bypass \(DIVBYP\)](#)).

In normal single-chip mode the E-clock output is off at reset to reduce the effects of RFI, but can be turned on if necessary.

In special single-chip mode the E-clock output is on at reset but can be turned off.

In special peripheral mode the E clock is an input to the MCU.

All clocks, including the E clock, are halted when the MCU is in STOP mode. It is possible to configure the MCU to interface to slow external memory. ECLK can be stretched for such accesses.

Pinout and Signal Descriptions

Reset ( $\overline{\text{RESET}}$ )

An active low bidirectional control signal,  $\overline{\text{RESET}}$ , acts as an input to initialize the MCU to a known start-up state. It also acts as an open-drain output to indicate that an internal failure has been detected in either the clock monitor or COP watchdog circuit. The MCU goes into reset asynchronously and comes out of reset synchronously. This allows the part to reach a proper reset state even if the clocks have failed, while allowing synchronized operation when starting out of reset.

It is possible to determine whether a reset was caused by an internal source or an external source. An internal source drives the pin low for 16 cycles; eight cycles later the pin is sampled. If the pin has returned high, either the COP watchdog vector or clock monitor vector will be taken. If the pin is still low, the external reset is determined to be active and the reset vector is taken. Hold reset low for at least 32 cycles to assure that the reset vector is taken in the event that an internal COP watchdog time-out or clock monitor fail occurs.

Maskable  
Interrupt Request  
( $\overline{\text{IRQ}}$ )

The  $\overline{\text{IRQ}}$  input provides a means of applying asynchronous interrupt requests to the MCU. Either falling edge-sensitive triggering or level-sensitive triggering is program selectable (INTCR register).  $\overline{\text{IRQ}}$  is always configured to level-sensitive triggering at reset. When the MCU is reset the  $\overline{\text{IRQ}}$  function is masked in the condition code register.

This pin is always an input and can always be read. There is an active pull-up on this pin while in reset and immediately out of reset. The pullup can be turned off by clearing PUPE in the PUCR register.

Nonmaskable  
Interrupt ( $\overline{\text{XIRQ}}$ )

The  $\overline{\text{XIRQ}}$  input provides a means of requesting a nonmaskable interrupt after reset initialization. During reset, the X bit in the condition code register (CCR) is set and any interrupt is masked until MCU software enables it. Because the  $\overline{\text{XIRQ}}$  input is level sensitive, it can be connected to a multiple-source wired-OR network. This pin is always an input and can always be read. There is an active pull-up on this pin while in reset and immediately out of reset. The pullup can be turned off by clearing PUPE in the PUCR register.  $\overline{\text{XIRQ}}$  is often used as a power loss detect interrupt.

Whenever  $\overline{XIRQ}$  or  $\overline{IRQ}$  are used with multiple interrupt sources ( $\overline{IRQ}$  must be configured for level-sensitive operation if there is more than one source of  $\overline{IRQ}$  interrupt), each source must drive the interrupt input with an open-drain type of driver to avoid contention between outputs. There must also be an interlock mechanism at each interrupt source so that the source holds the interrupt line low until the MCU recognizes and acknowledges the interrupt request. If the interrupt line is held low, the MCU will recognize another interrupt as soon as the interrupt mask bit in the MCU is cleared (normally upon return from an interrupt).

## Mode Select (SMODN, MODA, and MODB)

The state of these pins during reset determine the MCU operating mode. After reset, MODA and MODB can be configured as instruction queue tracking signals IPIPE0 and IPIPE1. MODA and MODB have active pulldowns during reset.

The SMODN pin can be used as BKGD or  $\overline{TAGHI}$  after reset.

## Single-Wire Background Mode Pin (BKGD)

The BKGD pin receives and transmits serial background debugging commands. A special self-timing protocol is used. The BKGD pin has an active pullup when configured as input; BKGD has no pullup control. Refer to [Development Support](#).

## External Address and Data Buses (ADDR[15:0] and DATA[15:0])

External bus pins share function with general-purpose I/O ports A and B. In single-chip operating modes, the pins can be used for I/O; in expanded modes, the pins are used for the external buses.

In expanded wide mode, ports A and B are used for multiplexed 16-bit data and address buses. PA[7:0] correspond to ADDR[15:8]/DATA[15:8]; PB[7:0] correspond to ADDR[7:0]/DATA[7:0].

In expanded narrow mode, ports A and B are used for the 16-bit address bus, and an 8-bit data bus is multiplexed with the most significant half of the address bus on port A. In this mode, 16-bit data is handled as two back-to-back bus cycles, one for the high byte followed by one for the low byte. PA[7:0] correspond to ADDR[15:8] and to DATA[15:8] or DATA[7:0], depending on the bus cycle. The state of the address pin

Pinout and Signal Descriptions

should be latched at the rising edge of E. To allow for maximum address setup time at external devices, a transparent latch should be used.

**Read/Write (R/W)** In all modes this pin can be used as I/O and is a general-purpose input with an active pull-up out of reset. If the read/write function is required it should be enabled by setting the RDWE bit in the PEAR register. External writes will not be possible until enabled.

**Low-Byte Strobe (LSTRB)** In all modes this pin can be used as I/O and is a general-purpose input with an active pull-up out of reset. If the strobe function is required, it should be enabled by setting the LSTRE bit in the PEAR register. This signal is used in write operations and so external low byte writes will not be possible until this function is enabled. This pin is also used as TAGLO in Special Expanded modes and is multiplexed with the LSTRB function.

**Instruction Queue Tracking Signals (IPIPE1 and IPIPE0)** These signals are used to track the state of the internal instruction execution queue. Execution state is time-multiplexed on the two signals. Refer to [Development Support](#).

**Data Bus Enable (DBE)** The DBE pin (PE7) is an active low signal that will be asserted low during E-clock high time. DBE provides separation between output of a multiplexed address and the input of data. When an external address is stretched, DBE is asserted during what would be the last quarter cycle of the last E-clock cycle of stretch. In expanded modes this pin is used to enable the drive control of external buses during external reads. Use of the DBE is controlled by the NDBE bit in the PEAR register. DBE is enabled out of reset in expanded modes. This pin has an active pullup during and after reset in single chip modes.

**Clock Divider Bypass (DIVBYP)** This feature is intended for test purposes only. The DIVBYP pin is input only. The logic state of this static signal is active high. There is an active pull-down on this pin to disable the clock divider bypass when left open. For application it is recommended to tie DIVBYP to VSS. The E-clock rate is 1/4 of the frequency applied to EXTAL.

For test the clock divider bypass is activated by setting DIVBYP to 1. The E-clock rate is 1/2 of the frequency applied to EXTAL.

**Table 5 MC68HC912BD32 Signal Description Summary**

Pin Name	Pin Number	Description
PW[3:0]	3–6	Pulse Width Modulator channel outputs.
ADDR[7:0] DATA[7:0]	25–18	External bus pins share function with general-purpose I/O ports A and B. In single chip modes, the pins can be used for I/O. In expanded modes, the pins are used for the external buses.
ADDR[15:8] DATA[15:8]	46–39	
IOC[7:0]	16–12, 9–7	Pins used for input capture and output compare in the timer and pulse accumulator subsystem.
PAI	16	Pulse accumulator input
AN[7:0]	58–51	Analog inputs for the analog-to-digital conversion module
DBE	26	Data bus control and, in expanded mode, enables the drive control of external buses during external reads.
MODB, MODA	27, 28	State of mode select pins during reset determine the initial operating mode of the MCU. After reset, MODB and MODA can be configured as instruction queue tracking signals IPIPE1 and IPIPE0 or as general-purpose I/O pins.
IPIPE1, IPIPE0	27, 28	
ECLK	29	E Clock is the output connection for the external bus clock. ECLK is used as a timing reference and for address demultiplexing.
RESET	32	An active low bidirectional control signal, $\overline{\text{RESET}}$ acts as an input to initialize the MCU to a known start-up state, and an output when COP or clock monitor causes a reset.
EXTAL	33	Crystal driver and external clock input pins. On reset all the device clocks are derived from the EXTAL input frequency. XTAL is the crystal output.
XTAL	34	
LSTRB	35	Low byte strobe (0 = low byte valid), in all modes this pin can be used as I/O. The low strobe function is the exclusive-NOR of A0 and the internal $\overline{\text{SZ8}}$ signal. (The $\overline{\text{SZ8}}$ internal signal indicates the size 16/8 access.)
TAGLO	35	Pin used in instruction tagging. See <a href="#">Development Support</a> .
R/W	36	Indicates direction of data on expansion bus. Shares function with general-purpose I/O. Read/write in expanded modes.
IRQ	37	Maskable interrupt request input provides a means of applying asynchronous interrupt requests to the MCU. Either falling edge-sensitive triggering or level-sensitive triggering is program selectable (INTCR register).
XIRQ	38	Provides a means of requesting asynchronous nonmaskable interrupt requests after reset initialization
BKGD	17	Single-wire background interface pin is dedicated to the background debug function. During reset, this pin determines special or normal operating mode.
TAGHI	17	Pin used in instruction tagging. See <a href="#">Development Support</a> .
Rx	76	Byteflight™ receive pin
Tx	75	Byteflight™ transmit pin

**Table 5 MC68HC912BD32 Signal Description Summary**

Pin Name	Pin Number	Description
$\overline{CS/SS}$	68	Slave select output for SPI master mode, input for slave mode or master mode.
SCK	67	Serial clock for SPI system.
SDO/MOSI	66	Master out/slave in pin for serial peripheral interface
SDI/MISO	65	Master in/slave out pin for serial peripheral interface
TxD	62	SCI transmit pin
RxD	61	SCI receive pin
DIVBYP	70	Clock divider bypass

## Port Signals

The MC68HC912BD32 incorporates eight ports which are used to control and access the various device subsystems. When not used for these purposes, port pins may be used for general-purpose I/O. In addition to the pins described below, each port consists of a data register which can be read and written at any time, and, with the exception of port AD, PE[1:0] and port SBI[1:0], a data direction register which controls the direction of each pin. After reset all port pins are configured as input.

### Port A

Port A pins are used for address and data in expanded modes. The port data register is not in the address map during expanded and peripheral mode operation. When it is in the map, port A can be read or written at anytime.

Register DDRA determines whether each port A pin is an input or output. DDRA is not in the address map during expanded and peripheral mode operation. Setting a bit in DDRA makes the corresponding bit in port A an output; clearing a bit in DDRA makes the corresponding bit in port A an input. The default reset state of DDRA is all zeroes.

When the PUPA bit in the PUCR register is set, all port A input pins are pulled-up internally by an active pull-up device. This bit has no effect if the port is being used in expanded modes as the pull-ups are inactive.

Setting the RDPA bit in register RDRIV causes all port A outputs to have reduced drive level. RDRIV can be written once after reset. RDRIV is not

in the address map in peripheral mode. Refer to [Bus Control and Input/Output](#).

## Port B

Port B pins are used for address and data in expanded modes. The port data register is not in the address map during expanded and peripheral mode operation. When it is in the map, port B can be read or written at anytime.

Register DDRB determines whether each port B pin is an input or output. DDRB is not in the address map during expanded and peripheral mode operation. Setting a bit in DDRB makes the corresponding bit in port B an output; clearing a bit in DDRB makes the corresponding bit in port B an input. The default reset state of DDRB is all zeroes.

When the PUPB bit in the PUCR register is set, all port B input pins are pulled-up internally by an active pull-up device. This bit has no effect if the port is being used in expanded modes as the pull-ups are inactive.

Setting the RDPB bit in register RDRIV causes all port B outputs to have reduced drive level. RDRIV can be written once after reset. RDRIV is not in the address map in peripheral mode. Refer to [Bus Control and Input/Output](#).

## Port E

Port E pins operate differently from port A and B pins. Port E pins are used for bus control signals and interrupt service request signals. When a pin is not used for one of these specific functions, it can be used as general-purpose I/O. However, two of the pins (PE[1:0]) can only be used for input, and the states of these pins can be read in the port data register even when they are used for  $\overline{IRQ}$  and  $\overline{XIRQ}$ .

The PEAR register determines pin function, and register DDRE determines whether each pin is an input or output when it is used for general-purpose I/O. PEAR settings override DDRE settings. Because PE[1:0] are input-only pins, only DDRE[7:2] have effect. Setting a bit in the DDRE register makes the corresponding bit in port E an output; clearing a bit in the DDRE register makes the corresponding bit in port E an input. The default reset state of DDRE is all zeroes.

When the PUPE bit in the PUCR register is set, PE[7,3,2,1,0] are pulled up. PE[7,3,2,1,0] are pulled up active devices, while PE1 is always pulled up by means of an internal resistor.

Neither port E nor DDRE is in the map in peripheral mode; neither is in the internal map in expanded modes with EME set.

Setting the RDPE bit in register RDRIV causes all port E outputs to have reduced drive level. RDRIV can be written once after reset. RDRIV is not in the address map in peripheral mode. Refer to [Bus Control and Input/Output](#).

**Port SBI**

The port SBI has four general-purpose I/O pins, PSBI[5:2]. The DIVBYP pin, the Byteflight™ receive pin, Rx, and transmit pin, Tx, cannot be configured as general-purpose I/O on port SBI.

Register DDRSBI determines whether each port SBI pin PSBI[5:2] is an input or output. Setting a bit in DDRSBI makes the corresponding pin in port SBI an output; clearing a bit makes the corresponding pin an input. After reset port SBI pins PSBI[5:2] are configured as inputs.

When a read to the port SBI is performed, the values for Bit 7 and Bit 6 depend on the contents of the port SBI data register, PORTSBI[7:6] and the of contents of DDRSBI[7:6]. Refer to [Table 6](#) for the returned values.

**Table 6 Port SBI Read accesses**

DDRSBI[Bit x]	Read data values		
	Bit 7	Bit 6	Bit 5... Bit 2
0	0	DIVBYP	PSBI[5:2]
1	PORTSBI[7]	PORTSBI[6]	PORTSBI[5:2]

When the PUESBI bit in the PCTLSBI register is set, port SBI input pins PSBI[5:2] are pulled up internally by an active pull-up device.

Setting the RDRSBI bit in register PCTLSBI causes the port SBI outputs PSBI[5:2] to have reduced drive level. Levels are at normal drive capability after reset. RDRSBI can be written anytime after reset. Refer to [Byteflight™ Module](#).



## Port AD

Input to the analog-to-digital subsystem and general-purpose input. When analog-to-digital functions are not enabled, the port has eight general-purpose input pins, PAD[7:0]. The ADPU bit in the ATDCTL2 register enables the A/D function.

Port AD pins are inputs; no data direction register is associated with this port. The port has no resistive input loads and no reduced drive controls. Refer to [Analog to Digital Converter](#).

## Port P

The four pulse-width modulation channel outputs share general-purpose port P pins. The PWM function is enabled with the PWEN register. Enabling PWM pins takes precedence over the general-purpose port. When pulse-width modulation is not in use, the port pins may be used for general-purpose I/O.

Register DDRP determines pin direction of port P when used for general-purpose I/O. When DDRP bits are set, the corresponding pin is configured for output. On reset the DDRP bits are cleared and the corresponding pin is configured for input.

When the PUPP bit in the PWCTL register is set, all input pins are pulled up internally by an active pull-up device. Pullups are disabled after reset.

Setting the RDPP bit in the PWCTL register configures all port P outputs to have reduced drive levels. Levels are at normal drive capability after reset. The PWCTL register can be read or written anytime after reset. Refer to [Pulse Width Modulator](#).

## Port T

This port provides eight general-purpose I/O pins when not enabled for input capture and output compare in the timer and pulse accumulator subsystem. The TEN bit in the TSCR register enables the timer function. The pulse accumulator subsystem is enabled with the PAEN bit in the PACTL register.

Register DDRT determines pin direction of port T when used for general-purpose I/O. When DDRT bits are set, the corresponding pin is configured for output. On reset the DDRT bits are cleared and the corresponding pin is configured for input.

When the PUPT bit in the TMSK2 register is set, all input pins are pulled up internally by an active pull-up device. Pullups are disabled after reset.

Setting the RDPT bit in the TMSK2 register configures all port T outputs to have reduced drive levels. Levels are at normal drive capability after reset. The TMSK2 register can be read or written anytime after reset Refer to [Standard Timer Module](#).

Port S

Port S is the 8-bit interface to the standard serial interface consisting of the serial communications interface (SCI) and serial peripheral interface (SPI) subsystems. Port S pins are available for general-purpose parallel I/O when standard serial functions are not enabled.

Port S pins serve several functions depending on the various internal control registers. If WOMS bit in the SC0CR1 register is set, the P-channel drivers of the output buffers are disabled for bits 0 through 1 (2 through 3). If SWOM bit in the SP0CR1 register is set, the P-channel drivers of the output buffers are disabled for bits 4 through 7. (wired-OR mode). The open drain control effects to both the serial and the general-purpose outputs. If the RDPSx bits in the PURDS register are set, the appropriate Port S pin drive capabilities are reduced. If PUPSx bits in the PURDS register are set, the appropriate pull-up device is connected to each port S pin which is programmed as a general-purpose input. If the pin is programmed as a general-purpose output, the pull-up is disconnected from the pin regardless of the state of the individual PUPSx bits. See [Serial Interface](#).

**Table 7 MC68HC912BD32 Port Description Summary**

Port Name	Pin Numbers	Data Direction DD Register (Address)	Description
Port A PA[7:0]	46–39	In/Out DDRA (\$0002)	Port A and port B pins are used for <b>address</b> and <b>data</b> in expanded modes. The port data registers are not in the address map during expanded and peripheral mode operation. When in the map, port A and port B can be read or written any time. DDRA and DDRB are not in the address map in expanded or peripheral modes.
Port B PB[7:0]	25–18	In/Out DDRDB (\$0003)	
Port AD PAD[7:0]	58–51	In	<b>Analog-to-digital converter</b> and general-purpose I/O.

**Table 7 MC68HC912BD32 Port Description Summary**

Port Name	Pin Numbers	Data Direction DD Register (Address)	Description
Port SBI DIVBYP PSBI[5:2] TxSBI RxSBI	70–76	In/Out DDRSBI (\$0112) for PSBI[5:2] TxSBI Out RxSBI, DIVBYP In	<b>Byteflight™</b> subsystem with Tx output, Rx and divider bypass input and general-purpose I/O on PSBI[5:2].
Port E PE[7:0]	26–29, 35–38	PE[1:0] In PE[7:2] In/Out DDRE (\$0009)	<b>Mode selection, bus control signals and interrupt service request</b> signals; or general-purpose I/O.
Port P PP[7:0]	79, 80, 1–6	In/Out DDRP (\$0057)	General-purpose I/O. PP[3:0] are use with the <b>pulse-width modulator</b> when enabled.
Port S PS[7:0]	68–61	In/Out DDRS (\$00D7)	<b>Serial communications interface and serial peripheral interface</b> subsystems and general-purpose I/O.
Port T PT[7:0]	16–12, 9–7	In/Out DDRT (\$00AF)	General-purpose I/O when not enabled for input capture and output compare in the <b>timer and pulse accumulator</b> subsystem.

## Port Pull-Up, Pull-Down and Reduced Drive

MCU ports can be configured for internal pull-up. To reduce power consumption and RFI, the pin output drivers can be configured to operate at a reduced drive level. Reduced drive causes a slight increase in transition time depending on loading and should be used only for ports which have a light loading. [Table 8](#) summarizes the port pull-up default status and controls.

**Table 8 Port Pull-Up, Pull-Down and Reduced Drive Summary**

Port Name	Resistive Input Loads	Enable Bit			Reduced Drive Control Bit		
		Register (Address)	Bit Name	Reset State	Register (Address)	Bit Name	Reset State
Port A	Pull-up	PUCR (\$000C)	PUPA	Disabled	RDRIV (\$000D)	RDPA	Full Drive
Port B	Pull-up	PUCR (\$000C)	PUPB	Disabled	RDRIV (\$000D)	RDPB	Full Drive
Port E:							
PE7, PE[3:0]	Pull-up	PUCR (\$000C)	PUPE	Enabled	RDRIV (\$000D)	RDPE	Full Drive
PE[6:4]	None	—			RDRIV (\$000D)	RDPE	Full Drive
PE[6:5]	Pull-down	Enabled During Reset			—	—	—

**Table 8 Port Pull-Up, Pull-Down and Reduced Drive Summary**

		Enable Bit			Reduced Drive Control Bit		
Port P	Pull-up	PWCTL (\$0054)	PUPP	Disabled	PWCTL (\$0054)	RDPP	Full Drive
Port S	Pull-up	PURDS (\$00DB)	PUPS0	Disabled	PURDS (\$00DB)	RDPS0	Full Drive
PS[3:2]	Pull-up	PURDS (\$00DB)	PUPS1	Disabled	PURDS (\$00DB)	RDPS1	Full Drive
PS[7:4]	Pull-up	PURDS (\$00DB)	PUPS2	Disabled	PURDS (\$00DB)	RDPS2	Full Drive
Port T	Pull-up	TMSK2 (\$008D)	PUPT	Disabled	TMSK2 (\$008D)	RDPT	Full Drive
Port SBI:							
DIVBYP	Pull-down	Always enabled			—		
PSBI[5:2]	Pull-up	PCTLSBI (\$0110)	PUESBI	Disabled	PCTLSBI (\$0110)	RDRSBI	Full Drive
TxSBI	None	—			—	—	Full Drive
RxSBI	Pull-up	—	—	Enabled	—		
Port AD	None	—			—		
BKGD	Pull-up	—	—	Enabled	—	—	Full Drive

Contents

Introduction ..... 33

Introduction

The register block can be mapped to any 2-Kbyte boundary within the standard 64-Kbyte address space by manipulating bits REG[15:11] in the INITRG register. INITRG establishes the upper five bits of the register block's 16-bit address. The register block occupies the first 512 bytes of the 2-Kbyte block. Default addressing (after reset) is indicated in the table below. For additional information refer to 5 Operating Modes and Resource Mapping.

**Table 9 MC68HC912BD32 Register Map (Sheet 1 of 9)**

Address	Bit 7	6	5	4	3	2	1	Bit 0	Name
\$0000	PA7	PA6	PA5	PA4	PA3	PA2	PA1	PA0	PORTA <sup>(1)</sup>
\$0001	PB7	PB6	PB5	PB4	PB3	PB2	PB1	PB0	PORTB
\$0002	DDA7	DDA6	DDA5	DDA4	DDA3	DDA2	DDA1	DDA0	DDRA
\$0003	DDB7	DDB6	DDB5	DDB4	DDB3	DDB2	DDB1	DDB0	DDRB
\$0004	0	0	0	0	0	0	0	0	Reserved
\$0005	0	0	0	0	0	0	0	0	Reserved
\$0006	0	0	0	0	0	0	0	0	Reserved
\$0007	0	0	0	0	0	0	0	0	Reserved
\$0008	PE7	PE6	PE5	PE4	PE3	PE2	PE1	PE0	PORTE <sup>(2)</sup>
\$0009	DDE7	DDE6	DDE5	DDE4	DDE3	DDE2	0	0	DDRE
\$000A	NDBE	0	PIPOE	NECLK	LSTRE	RDWE	0	0	PEAR
\$000B	SMODN	MODB	MODA	ESTR	IVIS	EBSWAI	0	EME	MODE <sup>(3)</sup>

Table 9 MC68HC912BD32 Register Map (Sheet 2 of 9)

Address	Bit 7	6	5	4	3	2	1	Bit 0	Name
\$000C	0	0	0	PUPE	0	0	PUPB	PUPA	PUCR
\$000D	0	0	0	0	RDPE	0	RDPB	RDPA	RDRIV
\$000E	0	0	0	0	0	0	0	0	Reserved
\$000F	0	0	0	0	0	0	0	0	Reserved
\$0010	RAM15	RAM14	RAM13	RAM12	RAM11	0	0	0	INITRM
\$0011	REG15	REG14	REG13	REG12	REG11	0	0	MMSWAI	INITRG
\$0012	EE15	EE14	EE13	EE12	0	0	0	EEON	INITEE
\$0013	0	NDRF	RFSTR1	RFSTR0	EXSTR1	EXSTR0	MAPROM	ROMON	MISC
\$0014	RTIE	RSWAI	RSBCK	0	RTBYP	RTR2	RTR1	RTR0	RTICTL
\$0015	RTIF	0	0	0	0	0	0	0	RTIFLG
\$0016	CME	FCME	FCM	FCOP	DISR	CR2	CR1	CR0	COPCTL
\$0017	Bit 7	6	5	4	3	2	1	Bit 0	COPRST
\$0018	ITE6	ITE8	ITEA	ITEC	ITEE	ITF0	ITF2	ITF4	ITST0
\$0019	ITD6	ITD8	ITDA	ITDC	ITDE	ITE0	ITE2	ITE4	ITST1
\$001A	ITC6	ITC8	ITCA	ITCC	ITCE	ITD0	ITD2	ITD4	ITST2
\$001B	0	0	0	0	0	ITC0	ITC2	ITC4	ITST3
\$001C-\$001D	0	0	0	0	0	0	0	0	Reserved
\$001E	IRQE	IRQEN	DLY	0	0	0	0	0	INTCR
\$001F	1	1	PSEL5	PSEL4	PSEL3	PSEL2	PSEL1	0	HPRIO
\$0020	BKEN1	BKEN0	BKPM	0	BK1ALE	BK0ALE	0	0	BRKCT0
\$0021	0	BKDBE	BKMBH	BKMBL	BK1RWE	BK1RW	BK0RWE	BK0RW	BRKCT1
\$0022	Bit 15	14	13	12	11	10	9	Bit 8	BRKAH
\$0023	Bit 7	6	5	4	3	2	1	Bit 0	BRKAL
\$0024	Bit 15	14	13	12	11	10	9	Bit 8	BRKDH
\$0025	Bit 7	6	5	4	3	2	1	Bit 0	BRKDL
\$0026-\$003F	0	0	0	0	0	0	0	0	Reserved
\$0040	CON23	CON01	PCKA2	PCKA1	PCKA0	PCKB2	PCKB1	PCKB0	PWCLK
\$0041	PCLK3	PCLK2	PCLK1	PCLK0	PPOL3	PPOL2	PPOL1	PPOL0	PWPOL
\$0042	0	0	0	0	PWEN3	PWEN2	PWEN1	PWEN0	PWEN
\$0043	0	6	5	4	3	2	1	Bit 0	PWPRES

Table 9 MC68HC912BD32 Register Map (Sheet 3 of 9)

Address	Bit 7	6	5	4	3	2	1	Bit 0	Name
\$0044	Bit 7	6	5	4	3	2	1	Bit 0	PWSCAL0
\$0045	Bit 7	6	5	4	3	2	1	Bit 0	PWSCNT0
\$0046	Bit 7	6	5	4	3	2	1	Bit 0	PWSCAL1
\$0047	Bit 7	6	5	4	3	2	1	Bit 0	PWSCNT1
\$0048	Bit 7	6	5	4	3	2	1	Bit 0	PWCNT0
\$0049	Bit 7	6	5	4	3	2	1	Bit 0	PWCNT1
\$004A	Bit 7	6	5	4	3	2	1	Bit 0	PWCNT2
\$004B	Bit 7	6	5	4	3	2	1	Bit 0	PWCNT3
\$004C	Bit 7	6	5	4	3	2	1	Bit 0	PWPER0
\$004D	Bit 7	6	5	4	3	2	1	Bit 0	PWPER1
\$004E	Bit 7	6	5	4	3	2	1	Bit 0	PWPER2
\$004F	Bit 7	6	5	4	3	2	1	Bit 0	PWPER3
\$0050	Bit 7	6	5	4	3	2	1	Bit 0	PWDTY0
\$0051	Bit 7	6	5	4	3	2	1	Bit 0	PWDTY1
\$0052	Bit 7	6	5	4	3	2	1	Bit 0	PWDTY2
\$0053	Bit 7	6	5	4	3	2	1	Bit 0	PWDTY3
\$0054	0	0	0	PSWAI	CENTR	RDP	PUPP	PSBCK	PWCTL
\$0055	DISCR	DISCP	DISCAL	0	0	0	0	0	PWTST
\$0056	PP7	PP6	PP5	PP4	PP3	PP2	PP1	PP0	PORTPP
\$0057	DDP7	DDP6	DDP5	DDP4	DDP3	DDP2	DDP1	DDP0	DDRP
\$0058-\$005F	0	0	0	0	0	0	0	0	Reserved
\$0060	0	0	0	0	0	0	0	0	ATDCTL0
\$0061	0	0	0	0	0	0	0	0	ATDCTL1
\$0062	ADPU	AFFC	AWAI	0	0	0	ASCIE	ASCIF	ATDCTL2
\$0063	0	0	0	0	0	0	FRZ1	FRZ0	ATDCTL3
\$0064	S10BM	SMP1	SMP0	PRS4	PRS3	PRS2	PRS1	PRS0	ATDCTL4
\$0065	0	S8CM	SCAN	MULT	CD	CC	CB	CA	ATDCTL5
\$0066	SCF	0	0	0	0	CC2	CC1	CC0	ATDSTAT
\$0067	CCF7	CCF6	CCF5	CCF4	CCF3	CCF2	CCF1	CCF0	ATDSTAT
\$0068	SAR9	SAR8	SAR7	SAR6	SAR5	SAR4	SAR3	SAR2	ATDTSTH
\$0069	SAR1	SAR0	RST	TSTOUT	TST3	TST2	TST1	TST0	ATDTSTL

Table 9 MC68HC912BD32 Register Map (Sheet 4 of 9)

Address	Bit 7	6	5	4	3	2	1	Bit 0	Name
\$006A-\$006E	0	0	0	0	0	0	0	0	Reserved
\$006F	PAD7	PAD6	PAD5	PAD4	PAD3	PAD2	PAD1	PAD0	PORTAD
\$0070	Bit 15	14	13	12	11	10	9	Bit 8	ADR0H
\$0071	Bit 7	6	5	4	3	2	1	Bit 0	ADR0L
\$0072	Bit 15	14	13	12	11	10	9	Bit 8	ADR1H
\$0073	Bit 7	6	5	4	3	2	1	Bit 0	ADR1L
\$0074	Bit 15	14	13	12	11	10	9	Bit 8	ADR2H
\$0075	Bit 7	6	5	4	3	2	1	Bit 0	ADR2L
\$0076	Bit 15	14	13	12	11	10	9	Bit 8	ADR3H
\$0077	Bit 7	6	5	4	3	2	1	Bit 0	ADR3L
\$0078	Bit 15	14	13	12	11	10	9	Bit 8	ADR4H
\$0079	Bit 7	6	5	4	3	2	1	Bit 0	ADR4L
\$007A	Bit 15	14	13	12	11	10	9	Bit 8	ADR5H
\$007B	Bit 7	6	5	4	3	2	1	Bit 0	ADR5L
\$007C	Bit 15	14	13	12	11	10	9	Bit 8	ADR6H
\$007D	Bit 7	6	5	4	3	2	1	Bit 0	ADR6L
\$007E	Bit 15	14	13	12	11	10	9	Bit 0	ADR7H
\$007F	Bit 7	6	5	4	3	2	1	Bit 0	ADR7L
\$0080	IOS7	IOS6	IOS5	IOS4	IOS3	IOS2	IOS1	IOS0	TIOS
\$0081	FOC7	FOC6	FOC5	FOC4	FOC3	FOC2	FOC1	FOC0	CFORC
\$0082	OC7M7	OC7M6	OC7M5	OC7M4	OC7M3	OC7M2	OC7M1	OC7M0	OC7M
\$0083	OC7D7	OC7D6	OC7D5	OC7D4	OC7D3	OC7D2	OC7D1	OC7D0	OC7D
\$0084	Bit 15	14	13	12	11	10	9	Bit 8	TCNT (H)
\$0085	Bit 7	6	5	4	3	2	1	Bit 0	TCNT (L)
\$0086	TEN	TSWAI	TSBCK	TFFCA	0	0	0	0	TSCR
\$0087	0	0	0	0	0	0	0	0	TQCR
\$0088	OM7	OL7	OM6	OL6	OM5	OL5	OM4	OL4	TCTL1
\$0089	OM3	OL3	OM2	OL2	OM1	OL1	OM0	OL0	TCTL2
\$008A	EDG7B	EDG7A	EDG6B	EDG6A	EDG5B	EDG5A	EDG4B	EDG4A	TCTL3
\$008B	EDG3B	EDG3A	EDG2B	EDG2A	EDG1B	EDG1A	EDG0B	EDG0A	TCTL4
\$008C	C7I	C6I	C5I	C4I	C3I	C2I	C1I	C0I	TMSK1



Table 9 MC68HC912BD32 Register Map (Sheet 5 of 9)

Address	Bit 7	6	5	4	3	2	1	Bit 0	Name
\$008D	TOI	0	PUPT	RDPT	TCRE	PR2	PR1	PR0	TMSK2
\$008E	C7F	C6F	C5F	C4F	C3F	C2F	C1F	C0F	TFLG1
\$008F	TOF	0	0	0	0	0	0	0	TFLG2
\$0090	Bit 15	14	13	12	11	10	9	Bit 8	TC0 (H)
\$0091	Bit 7	6	5	4	3	2	1	Bit 0	TC0 (L)
\$0092	Bit 15	14	13	12	11	10	9	Bit 8	TC1 (H)
\$0093	Bit 7	6	5	4	3	2	1	Bit 0	TC1 (L)
\$0094	Bit 15	14	13	12	11	10	9	Bit 8	TC2 (H)
\$0095	Bit 7	6	5	4	3	2	1	Bit 0	TC2 (L)
\$0096	Bit 15	14	13	12	11	10	9	Bit 8	TC3 (H)
\$0097	Bit 7	6	5	4	3	2	1	Bit 0	TC3 (L)
\$0098	Bit 15	14	13	12	11	10	9	Bit 8	TC4 (H)
\$0099	Bit 7	6	5	4	3	2	1	Bit 0	TC4 (L)
\$009A	Bit 15	14	13	12	11	10	9	Bit 8	TC5 (H)
\$009B	Bit 7	6	5	4	3	2	1	Bit 0	TC5 (L)
\$009C	Bit 15	14	13	12	11	10	9	Bit 8	TC6 (H)
\$009D	Bit 7	6	5	4	3	2	1	Bit 0	TC6 (L)
\$009E	Bit 15	14	13	12	11	10	9	Bit 8	TC7 (H)
\$009F	Bit 7	6	5	4	3	2	1	Bit 0	TC7 (L)
\$00A0	0	PAEN	PAMOD	PEDGE	CLK1	CLK0	PAOVI	PAI	PACTL
\$00A1	0	0	0	0	0	0	PAOVF	PAIF	PAFLG
\$00A2	Bit 15	14	13	12	11	10	9	Bit 8	PACNT
\$00A3	Bit 7	6	5	4	3	2	1	Bit 0	PACNT
\$00A4-\$00AC	0	0	0	0	0	0	0	0	Reserved
\$00AD	0	0	0	0	0	0	TCBYP	PCBYP	TIMTST
\$00AE	PT7	PT6	PT5	PT4	PT3	PT2	PT1	PT0	PORTT
\$00AF	DDT7	DDT6	DDT5	DDT4	DDT3	DDT2	DDT1	DDT0	DDRT
\$00B0-\$00BF	0	0	0	0	0	0	0	0	Reserved
\$00C0	BTST	BSPL	BRLD	SBR12	SBR11	SBR10	SBR9	SBR8	SC0BDH
\$00C1	SBR7	SBR6	SBR5	SBR4	SBR3	SBR2	SBR1	SBR0	SC0BDL

Table 9 MC68HC912BD32 Register Map (Sheet 6 of 9)

Address	Bit 7	6	5	4	3	2	1	Bit 0	Name
\$00C2	LOOPS	WOMS	RSRC	M	WAKE	ILT	PE	PT	SC0CR1
\$00C3	TIE	TCIE	RIE	ILIE	TE	RE	RWU	SBK	SC0CR2
\$00C4	TDRE	TC	RDRF	IDLE	OR	NF	FE	PF	SC0SR1
\$00C5	0	0	0	0	0	0	0	RAF	SC0SR2
\$00C6	R8	T8	0	0	0	0	0	0	SC0DRH
\$00C7	R7/T7	R6/T6	R5/T5	R4/T4	R3/T3	R2/T2	R1/T1	R0/T0	SC0DRL
\$00C8–\$00CF	0	0	0	0	0	0	0	0	Reserved
\$00D0	SPIE	SPE	SWOM	MSTR	CPOL	CPHA	SSOE	LSBF	SP0CR1
\$00D1	0	0	0	0	0	0	SSWAI	SPC0	SP0CR2
\$00D2	0	0	0	0	0	SPR2	SPR1	SPR0	SP0BR
\$00D3	SPIF	WCOL	0	MODF	0	0	0	0	SP0SR
\$00D4	0	0	0	0	0	0	0	0	Reserved
\$00D5	Bit 7	6	5	4	3	2	1	Bit 0	SP0DR
\$00D6	PS7	PS6	PS5	PS4	PS3	PS2	PS1	PS0	PORTS
\$00D7	DDS7	DDS6	DDS5	DDS4	DDS3	DDS2	DDS1	DDS0	DDRS
\$00D8–\$00DA	0	0	0	0	0	0	0	0	Reserved
\$00DB	0	RDPS2	RDPS1	RDPS0	0	PUPS2	PUPS1	PUPS0	PURDS
\$00DC–\$00DF	0	0	0	0	0	0	0	0	Reserved
\$00E0	0	0	0	0	0	SLDV2	SLDV1	SLDV0	SLOW
\$00E1–\$00EF	0	0	0	0	0	0	0	0	Reserved
\$00F0	NOBDM L	NOSHB	1	1	1	EESWAI	PROTLCK	EERC	EEMCR
\$00F1	SHPROT	1	1	BPROT4	BPROT3	BPROT2	BPROT1	BPROT0	EEPROT
\$00F2	EEODD	EEVEN	MARG	EECPD	EECPRD	0	EECPM	0	EETST
\$00F3	BULKP	0	0	BYTE	ROW	ERASE	EELAT	EEPGM	EEPORG
\$00F4	0	0	0	0	0	0	0	LOCK	FEELCK
\$00F5	0	0	0	0	0	0	0	BOOTP	FEEMCR
\$00F6	FSTE	GADR	HVT	FENLV	FDISVFP	VTCK	STRE	MWPR	FEETST
\$00F7	0	0	0	FEESWA I	SVFP	ERAS	LAT	ENPE	FEECTL

Table 9 MC68HC912BD32 Register Map (Sheet 7 of 9)

Address	Bit 7	6	5	4	3	2	1	Bit 0	Name
\$00F8-\$00FF	-	-	-	-	-	-	-	-	Reserved
\$0100	SFTRES	MASTER	ALARM	SLPRQ	SLPACK	WPULSE	SSWAI	0	MCR
\$0101	0	0	0	FSIZ4	FSIZ3	FSIZ2	FSIZ1	FSIZ0	FSIZR
\$0102	TWX0T7	TWX0T6	TWX0T5	TWX0T4	TWX0T3	TWX0T2	TWX0T1	TWX0T0	TCR1
\$0103	TWX0R7	TWX0R6	TWX0R5	TWX0R4	TWX0R3	TWX0R2	TWX0R1	TWX0R0	TCR2
\$0104	TWXD7	TWXD6	TWXD5	TWXD4	TWXD3	TWXD2	TWXD1	TWXD0	TCR3
\$0105	-	-	-	-	-	-	-	-	Reserved
\$0106	RCVFIF	RXIF	SYNAIF	SYNNIF	0	0	0	OPTDF	RISR
\$0107	TXIF	OVRNIF	ERRIF	SYNEIF	SYNLIF	ILLPIF	LOCKIF	WAKEIF	GISR
\$0108	RCVFIE	RXIE	SYNAIE	SYNNIE	0	0	0	0	RIER
\$0109	TXIE	OVRNIE	ERRIE	SYNEIE	SYNLIE	ILLPIE	LOCKIE	WAKEIE	GIER
\$010A	0	0	0	0	RIVEC3	RIVEC2	RIVEC1	RIVEC0	RIVEC
\$010B	0	0	0	0	TIVEC3	TIVEC2	TIVEC1	TIVEC0	TIVEC
\$010C	FIDAC7	FIDAC6	FIDAC5	FIDAC4	FIDAC3	FIDAC2	FIDAC1	FIDAC0	FIDAC
\$010D	FIDMR7	FIDMR6	FIDMR5	FIDMR4	FIDMR3	FIDMR2	FIDMR1	FIDMR0	FIDMR
\$010E	MVR7	MVR6	MVR5	MVR4	MVR3	MVR2	MVR1	MVR0	MVR
\$010F	0	0	0	0	0	0	0	TACC	SITEST
\$0110	0	0	0	PERREN	PROKEN	PSYNNEN	PUESBI	RDRSBI	PCTLSBI
\$0111	DIVBYP	PSBI6	PSBI5	PSBI4	PSBI3	PSBI2	TX	RX	PORTSBI
\$0112	DDRSBI7	DDRSBI6	DDRSBI5	DDRSBI4	DDRSBI3	DDRSBI2	0	0	DDRSBI
\$0113-\$011F	-	-	-	-	-	-	-	-	Reserved
\$0120	ID7	ID6	ID5	ID4	ID3	ID2	ID1	ID0	IDENTIFIER <sup>4</sup>
\$0121	reserved	reserved	reserved	reserved	LEN3	LEN2	LEN1	LEN0	DATA LENGTH
\$0122	D7	D6	D5	D4	D3	D2	D1	D0	DATA0
\$0123	D7	D6	D5	D4	D3	D2	D1	D0	DATA1
\$0124	D7	D6	D5	D4	D3	D2	D1	D0	DATA2
\$0125	D7	D6	D5	D4	D3	D2	D1	D0	DATA3
\$0126	D7	D6	D5	D4	D3	D2	D1	D0	DATA4
\$0127	D7	D6	D5	D4	D3	D2	D1	D0	DATA5
\$0128	D7	D6	D5	D4	D3	D2	D1	D0	DATA6

Table 9 MC68HC912BD32 Register Map (Sheet 8 of 9)

Address	Bit 7	6	5	4	3	2	1	Bit 0	Name
\$0129	D7	D6	D5	D4	D3	D2	D1	D0	DATA7
\$012A	D7	D6	D5	D4	D3	D2	D1	D0	DATA8
\$012B	D7	D6	D5	D4	D3	D2	D1	D0	DATA9
\$012C	D7	D6	D5	D4	D3	D2	D1	D0	DATA10
\$012D	D7	D6	D5	D4	D3	D2	D1	D0	DATA11
\$012E-\$012F	-	-	-	-	-	-	-	-	Reserved
\$0130	ID7	ID6	ID5	ID4	ID3	ID2	ID1	ID0	IDENTIFIER <sup>5</sup>
\$0131	reserved	reserved	reserved	reserved	LEN3	LEN2	LEN1	LEN0	DATA LENGTH
\$0132	D7	D6	D5	D4	D3	D2	D1	D0	DATA0
\$0133	D7	D6	D5	D4	D3	D2	D1	D0	DATA1
\$0134	D7	D6	D5	D4	D3	D2	D1	D0	DATA2
\$0135	D7	D6	D5	D4	D3	D2	D1	D0	DATA3
\$0136	D7	D6	D5	D4	D3	D2	D1	D0	DATA4
\$0137	D7	D6	D5	D4	D3	D2	D1	D0	DATA5
\$0138	D7	D6	D5	D4	D3	D2	D1	D0	DATA6
\$0139	D7	D6	D5	D4	D3	D2	D1	D0	DATA7
\$013A	D7	D6	D5	D4	D3	D2	D1	D0	DATA8
\$013B	D7	D6	D5	D4	D3	D2	D1	D0	DATA9
\$013C	D7	D6	D5	D4	D3	D2	D1	D0	DATA10
\$013D	D7	D6	D5	D4	D3	D2	D1	D0	DATA11
\$013E-\$013F	-	-	-	-	-	-	-	-	Reserved
\$0140	ID7	ID6	ID5	ID4	ID3	ID2	ID1	ID0	IDENTIFIER <sup>6</sup>
\$0141	reserved	reserved	reserved	reserved	LEN3	LEN2	LEN1	LEN0	DATA LENGTH
\$0142	D7	D6	D5	D4	D3	D2	D1	D0	DATA0
\$0143	D7	D6	D5	D4	D3	D2	D1	D0	DATA1
\$0144	D7	D6	D5	D4	D3	D2	D1	D0	DATA2
\$0145	D7	D6	D5	D4	D3	D2	D1	D0	DATA3
\$0146	D7	D6	D5	D4	D3	D2	D1	D0	DATA4
\$0147	D7	D6	D5	D4	D3	D2	D1	D0	DATA5
\$0148	D7	D6	D5	D4	D3	D2	D1	D0	DATA6

Table 9 MC68HC912BD32 Register Map (Sheet 9 of 9)

Address	Bit 7	6	5	4	3	2	1	Bit 0	Name
\$0149	D7	D6	D5	D4	D3	D2	D1	D0	DATA7
\$014A	D7	D6	D5	D4	D3	D2	D1	D0	DATA8
\$014B	D7	D6	D5	D4	D3	D2	D1	D0	DATA9
\$014C	D7	D6	D5	D4	D3	D2	D1	D0	DATA10
\$014D	D7	D6	D5	D4	D3	D2	D1	D0	DATA11
\$014E-\$014F	-	-	-	-	-	-	-	-	Reserved
\$0150	IFLG	IENA	LOCK	0	0	0	0	CFG	BUFCTL0
\$0151	IFLG	IENA	LOCK	0	0	0	0	CFG	BUFCTL1
\$0152	IFLG	IENA	LOCK	0	0	0	0	CFG	BUFCTL2
\$0153	IFLG	IENA	LOCK	0	0	0	0	CFG	BUFCTL3
\$0154	IFLG	IENA	LOCK	0	0	0	0	CFG	BUFCTL4
\$0155	IFLG	IENA	LOCK	0	0	0	0	CFG	BUFCTL5
\$0156	IFLG	IENA	LOCK	0	0	0	0	CFG	BUFCTL6
\$0157	IFLG	IENA	LOCK	0	0	0	0	CFG	BUFCTL7
\$0158	IFLG	IENA	LOCK	0	0	0	0	CFG	BUFCTL8
\$0159	IFLG	IENA	LOCK	0	0	0	0	CFG	BUFCTL9
\$015A	IFLG	IENA	LOCK	0	0	0	0	CFG	BUFCTL10
\$015B	IFLG	IENA	LOCK	0	0	0	0	CFG	BUFCTL11
\$015C	IFLG	IENA	LOCK	0	0	0	0	CFG	BUFCTL12
\$015D	IFLG	IENA	LOCK	0	0	0	0	CFG	BUFCTL13
\$015E	IFLG	IENA	LOCK	0	0	0	0	CFG	BUFCTL14
\$015F	IFLG	IENA	LOCK	0	0	0	0	CFG	BUFCTL15

1. Port A, port B, and data direction registers DDRA and DDRB are not in map in expanded and peripheral modes.
2. Port E and DDRE not in map in peripheral mode; also not in map in expanded modes with EME set.
3. Not in map in peripheral mode.
4. \$0120-\$012D: Byteflight™ Active Transmit Buffer Register
5. \$0130-\$013D: Byteflight™ Active Receive Buffer Register
6. \$0140-\$014D: Byteflight™ Active FIFO Register



# Operating Modes and Resource Mapping

---

---

## Contents

Introduction . . . . .	43
Operating Modes . . . . .	43
Background Debug Mode . . . . .	46
Internal Resource Mapping . . . . .	49
Memory Maps . . . . .	53

---

---

## Introduction

Eight possible operating modes determine the operating configuration of the MC68HC912BD32. Each mode has an associated default memory map and external bus configuration. After reset, most system resources can be mapped to other addresses by writing to the appropriate control registers.

---

---

## Operating Modes

The operating mode out of reset is determined by the states of the BKGD, MODB, and MODA pins during reset.

The SMODN, MODB, and MODA bits in the MODE register show current operating mode and provide limited mode switching during operation. The states of the BKGD, MODB, and MODA pins are latched into these bits on the rising edge of the reset signal. During reset an active pullup is connected to the BKGD pin (as input) and active pulldowns are connected to the MODB and MODA pins. If an open occurs on any of these pins, the device will operate in normal single-chip mode.

Table 10 Mode Selection

BKGD	MODB	MODA	Mode	Port A	Port B
0	0	0	Special Single Chip	General Purpose I/O	General Purpose I/O
0	0	1	Special Expanded Narrow	ADDR[15:8]/DATA[7:0]	ADDR[7:0]
0	1	0	Special Peripheral	ADDR/DATA	ADDR/DATA
0	1	1	Special Expanded Wide	ADDR/DATA	ADDR/DATA
1	0	0	Normal Single Chip	General Purpose I/O	General Purpose I/O
1	0	1	Normal Expanded Narrow	ADDR[15:8]/DATA[7:0]	ADDR[7:0]
1	1	0	Reserved (Forced to Peripheral)	—	—
1	1	1	Normal Expanded Wide	ADDR/DATA	ADDR/DATA

There are two basic types of operating modes:

Normal modes — some registers and bits are protected against accidental changes.

Special modes — allow greater access to protected control registers and bits for special purposes such as testing and emulation.

A system development and debug feature, background debug mode (BDM), is available in all modes. In special single-chip mode, BDM is active immediately after reset.

**Normal Operating Modes**

These modes provide three operating configurations. Background debugging is available in all three modes, but must first be enabled for some operations by means of a BDM command. BDM can then be made active by another BDM command.

*Normal Expanded Wide Mode*

This is a normal mode of operation in which the address and data are multiplexed onto ports A and B. ADDR[15:8] and DATA[15:8] are present on port A. ADDR[7:0] and DATA[7:0] are present on port B.

*Normal Expanded Narrow Mode*

Port A is configured as the high byte of address multiplexed with the 8-bit data bus. Port B is configured as the lower 8-bit address bus. This mode is used for lower cost production systems that use 8-bit wide external EEPROMs or RAMs. Such systems take extra bus cycles to access



16-bit locations but this may be preferred over the extra cost of additional external memory devices.

*Normal  
Single-Chip Mode*

There are no external address and data buses in this mode. All pins of ports A, B and E are configured as general-purpose I/O pins. Port E bits 1 and 0 are input-only with internal pullups and the other 22 pins are bidirectional I/O pins that are initially configured as high-impedance inputs. Port E pullups are enabled upon reset; port A and B pullups are disabled upon reset.

**Special Operating Modes**

There are three special operating modes that correspond to normal operating modes. These operating modes are commonly used in factory testing and system development. In addition, there is a special peripheral mode, in which an external master, such as an I.C. tester, can control the on-chip peripherals.

*Special Expanded Wide Mode*

This mode can be used for emulation of normal expanded wide mode and emulation of normal single-chip mode and 16-bit data bus. The bus control related pins in PORTE are all configured to serve their bus control output functions rather than general-purpose I/O.

*Special Expanded Narrow Mode*

This mode can be used for emulation of normal expanded narrow mode. In this mode external 16-bit data is handled as two back-to-back bus cycles, one for the high byte followed by one for the low byte. Internal operations continue to use full 16-bit data paths.

*Special Single-Chip Mode*

This mode can be used to force the MCU to active BDM mode to allow system debug through the BKGD pin. The MCU does not fetch the reset vector and execute application code as it would in other modes. Instead, the active background mode is in control of CPU execution and BDM firmware is waiting for additional serial commands through the BKGD pin. There are no external address and data buses in this mode. The MCU operates as a stand-alone device and all program and data space are on-chip. External port pins can be used for general-purpose I/O.

## Operating Modes and Resource Mapping

### *Special Peripheral Mode*

The CPU is not active in this mode. An external master can control on-chip peripherals for testing purposes. It is not possible to change to or from this mode without going through reset. Background debugging should not be used while the MCU is in special peripheral mode as internal bus conflicts between BDM and the external master can cause improper operation of both modes.

---

---

## Background Debug Mode

Background debug mode (BDM) is an auxiliary operating mode that is used for system development. BDM is implemented in on-chip hardware and provides a full set of debug operations. Some BDM commands can be executed while the CPU is operating normally. Other BDM commands are firmware based, and require the BDM firmware to be enabled and active for execution.

In special single-chip mode, BDM is enabled and active immediately out of reset. BDM is available in all other operating modes, but must be enabled before it can be activated. BDM should not be used in special peripheral mode because of potential bus conflicts.

Once enabled, background mode can be made active by a serial command sent via the BKGD pin or execution of a CPU12 BGND instruction. While background mode is active, the CPU can interpret special debugging commands, and read and write CPU registers, peripheral registers, and locations in memory.

While BDM is active, the CPU executes code located in a small on-chip ROM mapped to addresses \$FF00 to \$FFFF; BDM control registers are accessible at addresses \$FF00 to \$FF06. The BDM ROM replaces the regular system vectors while BDM is active. While BDM is active, the user memory from \$FF00 to \$FFFF is not in the map except through serial BDM commands.

BDM allows read and write access to internal memory-mapped registers and RAM, and read access to EEPROM and Flash EEPROM without interrupting the application code executing in the CPU. This non-intrusive mode uses dead bus cycles to access the memory and in

most cases will remain cycle deterministic. Refer to 16 Development Support for more details on BDM.

## MODE — Mode Register

\$000B

	Bit 7	6	5	4	3	2	1	Bit 0	
	SMODN	MODB	MODA	ESTR	IVIS	EBSWAI	0	EME	
RESET:	1	0	1	1	0	0	–	0	Normal Exp Narrow
RESET:	1	1	1	1	0	0	–	0	Normal Exp Wide
RESET:	0	0	1	1	1	0	–	1	Special Exp Narrow
RESET:	0	1	1	1	1	0	–	1	Special Exp Wide
RESET:	0	1	0	1	1	0	–	1	Peripheral
RESET:	1	0	0	1	0	0	–	0	Normal Single Chip
RESET:	0	0	0	1	1	0	–	1	Special Single Chip

MODE controls the MCU operating mode and various configuration options. This register is not in the map in peripheral mode

### SMODN, MODB, MODB — Mode Select Special, B and A

These bits show the current operating mode and reflect the status of the BKGD, MODB and MODA input pins at the rising edge of reset.

Read anytime. SMODN may only be written if SMODN = 0 (in special modes) but the first write is ignored; MODB, MODA may be written once if SMODN = 1; anytime if SMODN = 0, except that special peripheral and reserved modes cannot be selected.

### ESTR — E Clock Stretch Enable

Determines if the E Clock behaves as a simple free-running clock or as a bus control signal that is active only for external bus cycles.

ESTR is always one in expanded modes since it is required for address demultiplexing and must follow stretched cycles.

0 = E never stretches (always free running).

1 = E stretches high during external access cycles and low during non-visible internal accesses.

Normal modes: write once; Special modes: write anytime, read anytime.

#### IVIS — Internal Visibility

This bit determines whether internal ADDR/DATA,  $R/\overline{W}$ , and  $\overline{LSTRB}$  signals can be seen on the bus during accesses to internal locations. In special expanded narrow mode, it is possible to configure the MCU to show internal accesses on an external 16-bit bus. The IVIS control bit must be set to 1. When the system is configured this way, visible internal accesses are shown as if the MCU was configured for expanded wide mode but normal external accesses operate as if the bus was in narrow mode. In normal expanded narrow mode, internal visibility is not allowed and IVIS is ignored.

0 = No visibility of internal bus operations on external bus

1 = Internal bus operations are visible on external bus

Normal modes: write once; Special modes: write anytime EXCEPT the first time. Read anytime.

#### EBSWAI — External Bus Module Stop in Wait Control

This bit controls access to the external bus interface when in Wait mode. The module will delay before shutting down in Wait mode to allow for final bus activity to complete.

0 = External bus and registers continue functioning during Wait mode.

1 = External bus is shut down during Wait mode.

#### EME — Emulate Port E

Removing the registers from the map allows the user to emulate the function of these registers externally. In single-chip mode PORTE and DDRE are always in the map regardless of the state of this bit.

0 = PORTE and DDRE are in the memory map.

1 = PORTE and DDRE are removed from the internal memory map (expanded mode).

Normal modes: write once; special modes: write anytime EXCEPT the first time. Read anytime.

---

---

## Internal Resource Mapping

The internal register block, RAM, Flash EEPROM and EEPROM have default locations within the 64K byte standard address space but may be reassigned to other locations during program execution by setting bits in mapping registers INITRG, INITRM, and INITEE. During normal operating modes these registers can be written once. It is advisable to explicitly establish these resource locations during the initialization phase of program execution, even if default values are chosen, in order to protect the registers from inadvertent modification later.

Writes to the mapping registers go into effect between the cycle that follows the write and the cycle after that. To assure that there are no unintended operations, a write to one of these registers should be followed with a NOP instruction.

If conflicts occur when mapping resources, the register block will take precedence over the other resources; RAM, Flash EEPROM, or EEPROM addresses occupied by the register block will not be available for storage. When active, BDM ROM takes precedence over other resources although a conflict between BDM ROM and register space is not possible. [Table 11](#) shows resource mapping precedence.

All address space not utilized by internal resources is by default external memory.

**Table 11 Mapping Precedence**

Precedence	Resource
1	BDM ROM (if active)
2	Register Space
3	RAM
4	EEPROM
5	Flash EEPROM
6	External Memory

### Register Block Mapping

After reset the 512 byte register block resides at location \$0000 but can be reassigned to any 2K byte boundary within the standard 64K byte address space. Mapping of internal registers is controlled by five bits in

Operating Modes and Resource Mapping

the INITRG register. The register block occupies the first 512 bytes of the 2K byte block.

**INITRG** — Initialization of Internal Register Position Register **\$0011**

	Bit 7	6	5	4	3	2	1	Bit 0
	REG15	REG14	REG13	REG12	REG11	0	0	MMSWAI
RESET:	0	0	0	0	0	0	0	0

**REG[15:11]** — Internal register map position

These bits specify the upper five bits of the 16-bit registers address. Write once in normal modes or anytime in special modes. Read anytime.

**MMSWAI** — Memory Mapping Interface Stop in Wait Control

This bit controls access to the memory mapping interface when in Wait mode.

- 0 = Memory mapping interface continues to function during Wait mode.
- 1 = Memory mapping interface access is shut down during Wait mode.

**RAM Mapping**

The MC68HC912BD32 has 1K byte of fully static RAM that is used for storing instructions, variables, and temporary data during program execution. After reset, RAM addressing begins at location \$0800 but can be assigned to any 2K byte boundary within the standard 64K byte address space. Mapping of internal RAM is controlled by five bits in the INITRM register. The RAM array occupies the first 1K byte of the 2K byte block.

**INITRM** — Initialization of Internal RAM Position Register **\$0010**

	Bit 7	6	5	4	3	2	1	Bit 0
	RAM15	RAM14	RAM13	RAM12	RAM11	0	0	0
RESET:	0	0	0	0	1	0	0	0

**RAM[15:11]** — Internal RAM map position

These bits specify the upper five bits of the 16-bit RAM address.

Write once in normal modes or anytime in special modes. Read anytime.

**EEPROM Mapping** The MC68HC912BD32 has 768 bytes of EEPROM which is activated by the EEON bit in the INITEE register.

Mapping of internal EEPROM is controlled by four bits in the INITEE register. After reset EEPROM address space begins at location \$0D00 but can be mapped to any 4K byte boundary within the standard 64K byte address space.

**INITEE**— Initialization of Internal EEPROM Position Register **\$0012**

	Bit 7	6	5	4	3	2	1	Bit 0
	EE15	EE14	EE13	EE12	0	0	0	EEON
RESET:	0	0	0	0	0	0	0	1

**EE[15:12]** — Internal EEPROM map position

These bits specify the upper four bits of the 16-bit EEPROM address. Write once in normal modes or anytime in special modes. Read anytime.

**EEON** — Internal EEPROM On (Enabled)

The EEON bit allows read access to the EEPROM array. EEPROM control registers can be accessed and EEPROM locations may be programmed or erased regardless of the state of EEON.

This bit is forced to one in single-chip modes. Read or write anytime.

0 = Removes the EEPROM from the map

1 = Places the on-chip EEPROM in the memory map

**Flash EEPROM and Expansion Address Mapping**

Additional mapping controls are available that can be used in conjunction with Flash EEPROM and memory expansion.

The 32K byte Flash EEPROM can be mapped to either the upper or lower half of the 64K byte address space. When mapping conflicts occur, registers, RAM and EEPROM have priority over Flash EEPROM. To use memory expansion the part must be operated in one of the expanded modes.

Operating Modes and Resource Mapping

MISC — Miscellaneous Mapping Control Register

\$0013

	Bit 7	6	5	4	3	2	1	Bit 0	
	0	NDRF	RFSTR1	RFSTR0	EXSTR1	EXSTR0	MAPROM	ROMON	
RESET:	0	0	0	0	1	1	0	0	Ex. mode
	0	0	0	0	1	1	1	1	Single-chip mode

This register can be read anytime. In Normal modes MISC can be written once; in Special modes it can be written anytime.

NDRF — Narrow Data Bus for Register-Following Map

This bit enables a narrow bus feature for the 512-byte register-following map. In Expanded Narrow (eight bit) modes, Single Chip modes, and Peripheral mode, NDRF has no effect. The register-following map always begins at the byte following the 512-byte register map. If the registers are moved this space will also move.

- 0 = Register-following map space acts as a full 16-bit data bus
- 1 = Register-following map space acts the same as an 8-bit external data bus

RFSTR1, RFSTR0 — Register-Following Stretch Bit 1 and Bit 0

These bits determine the amount of clock stretch on accesses to the 512-byte register-following map. It is valid regardless of the state of the NDRF bit. In Single Chip and Peripheral modes this bit has no meaning or effect.

Table 12 Register-Following Stretch-Bit Definition

Stretch bit RFSTR1	Stretch bit RFSTR0	E Clocks Stretched
0	0	0
0	1	1
1	0	2
1	1	3

EXSTR1, EXSTR0 — External Access Stretch Bit1 and Bit0

These bits determine the amount of clock stretch on accesses to the external address space. In Single Chip and Peripheral modes this bit has no meaning or effect.



**Table 13 Expanded Stretch-Bit Definition**

Stretch bit EXSTR1	Stretch bit EXSTR0	E Clocks Stretched
0	0	0
0	1	1
1	0	2
1	1	3

**MAPROM — Map Location of Flash EEPROM**

This bit determines the location of the on-chip Flash EEPROM. In Expanded modes it is reset to zero. In Single Chip modes it is reset to one. If ROMON is zero, this bit has no meaning or effect.

0 = Flash EEPROM is located from \$0000 to \$7FFF

1 = Flash EEPROM is located from \$8000 to \$FFFF

**ROMON — Enable Flash EEPROM**

In Expanded modes ROMON is reset to zero. In Single Chip modes it is reset to one. If the internal RAM, registers, EEPROM, or BDM ROM (if active) are mapped to the same space as the Flash EEPROM, they will have priority over the Flash EEPROM.

0 = Disables the Flash EEPROM in the memory map

1 = Enables the Flash EEPROM in the memory map

---

---

**Memory Maps**

The following diagrams illustrate the memory map for each mode of operation immediately after reset.

Operating Modes and Resource Mapping

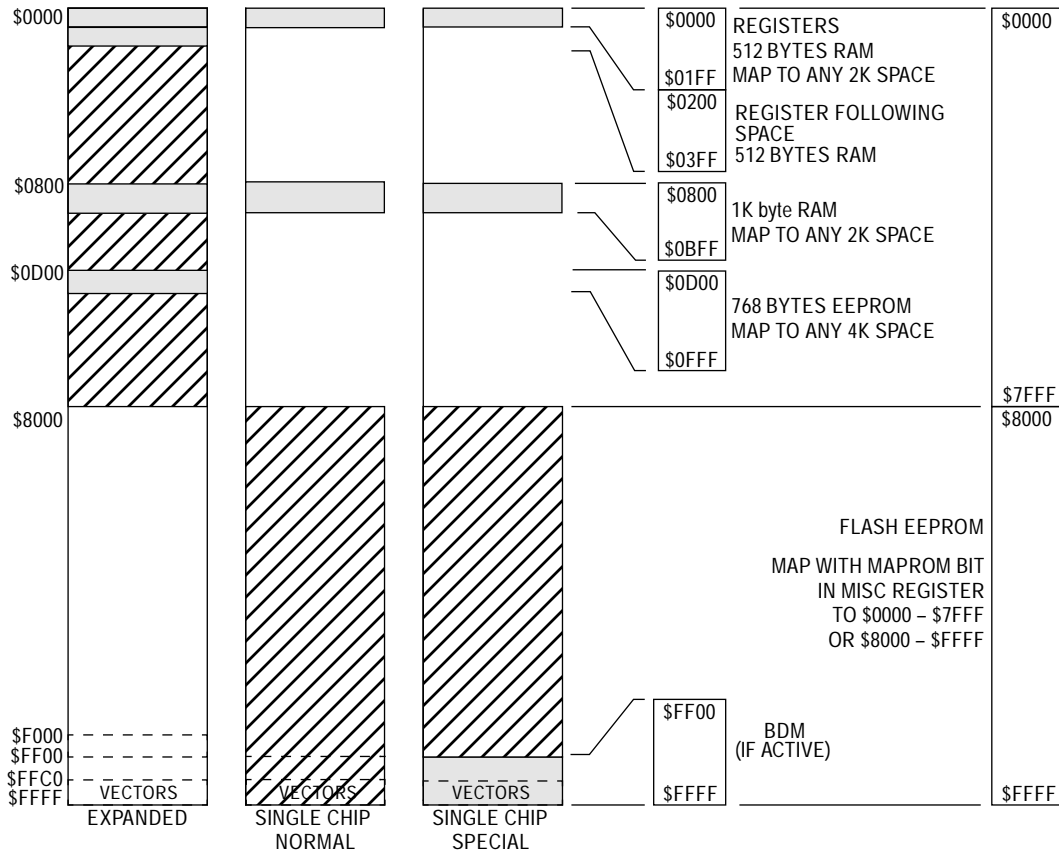

Figure 6 MC68HC912BD32 Memory Map

# Bus Control and Input/Output

---

---

## Contents

Introduction .....	55
Detecting Access Type from External Signals .....	55
Registers .....	56

---

---

## Introduction

Internally the MC68HC912BD32 has full 16-bit data paths, but depending upon the operating mode and control registers, the external bus may be 8 or 16 bits. There are cases where 8-bit and 16-bit accesses can appear on adjacent cycles using the  $\overline{\text{LSTRB}}$  signal to indicate 8- or 16-bit data.

---

---

## Detecting Access Type from External Signals

The external signals  $\overline{\text{LSTRB}}$ ,  $\overline{\text{R/W}}$ , and  $\text{A0}$  can be used to determine the type of bus access that is taking place. Accesses to the internal RAM module are the only type of access that produce  $\overline{\text{LSTRB}}=\text{A0}=1$ , because the internal RAM is specifically designed to allow misaligned 16-bit accesses in a single cycle. In these cases the data for the address that was accessed is on the low half of the data bus and the data for address + 1 is on the high half of the data bus (data order is swapped).

Table 14 Access Type vs. Bus Control Pins

LSTRB	A0	R/W	Type of Access
1	0	1	8-bit read of an even address
0	1	1	8-bit read of an odd address
1	0	0	8-bit write of an even address
0	1	0	8-bit write of an odd address
0	0	1	16-bit read of an even address
1	1	1	16-bit read of an odd address (low/high data swapped)
0	0	0	16-bit write to an even address
1	1	0	16-bit write to an odd address (low/high data swapped)

---



---

## Registers

Not all registers are visible in the MC68HC912BD32 memory map under certain conditions. In special peripheral mode the first 16 registers associated with bus expansion are removed from the memory map.

In expanded modes, some or all of port A, port B, and port E are used for expansion buses and control signals. In order to allow emulation of the single-chip functions of these ports, some of these registers must be rebuilt in an external port replacement unit. In any expanded mode port A and port B are used for address and data lines so registers for these ports, as well as the data direction registers for these ports, are removed from the on-chip memory map and become external accesses.

In any expanded mode, port E pins may be needed for bus control (e.g., ECLK,  $R/\overline{W}$ ). To regain the single-chip functions of port E, the emulate port E (EME) control bit in the MODE register may be set. In this special case of expanded mode and EME set, PORTE and DDRE registers are removed from the on-chip memory map and become external accesses so port E may be rebuilt externally.

## PORTA — Port A Register

**\$0000**

	Bit 7	6	5	4	3	2	1	Bit 0
Single Chip	PA7	PA6	PA5	PA4	PA3	PA2	PA1	PA0
RESET:	—	—	—	—	—	—	—	—
Exp Wide & Periph:	ADDR15 DATA15	ADDR14 DATA14	ADDR13 DATA13	ADDR12 DATA12	ADDR11 DATA11	ADDR10 DATA10	ADDR9 DATA9	ADDR8 DATA8
Expanded Narrow	ADDR15 DATA15/7	ADDR14 DATA14/6	ADDR13 DATA13/5	ADDR12 DATA12/4	ADDR11 DATA11/3	ADDR10 DATA10/2	ADDR9 DATA9/1	ADDR8 DATA8/0

Bits PA[7:0] are associated with addresses ADDR[15:8] and DATA[15:8]. When this port is not used for external addresses and data, such as in single-chip mode, these pins can be used as general-purpose I/O. DDRA determines the primary direction of each pin. This register is not in the on-chip map in expanded and peripheral modes. Read and write anytime.

## DDRA — Port A Data Direction Register

**\$0002**

	Bit 7	6	5	4	3	2	1	Bit 0
	DDA7	DDA6	DDA5	DDA4	DDA3	DDA2	DDA1	DDA0
RESET:	0	0	0	0	0	0	0	0

This register determines the primary direction for each port A pin when functioning as a general-purpose I/O port. DDRA is not in the on-chip map in expanded and peripheral modes. Read and write anytime.

0 = Associated pin is a high-impedance input

1 = Associated pin is an output

## PORTB — Port B Register

**\$0001**

	Bit 7	6	5	4	3	2	1	Bit 0
Single Chip	PB7	PB6	PB5	PB4	PB3	PB2	PB1	PB0
RESET:	—	—	—	—	—	—	—	—
Exp Wide & Periph:	ADDR7 DATA7	ADDR6 DATA6	ADDR5 DATA5	ADDR4 DATA4	ADDR3 DATA3	ADDR2 DATA2	ADDR1 DATA1	ADDR0 DATA0
Expanded Narrow	ADDR7	ADDR6	ADDR5	ADDR4	ADDR3	ADDR2	ADDR1	ADDR0

Bus Control and Input/Output

Bits PB[7:0] are associated with addresses ADDR[7:0] and DATA[7:0]. When this port is not used for external addresses and data such as in single-chip mode, these pins can be used as general-purpose I/O. DDRB determines the primary direction of each pin. This register is not in the on-chip map in expanded and peripheral modes. Read and write anytime.

DDRB — Port B Data Direction Register

\$0003

	Bit 7	6	5	4	3	2	1	Bit 0
	DDB7	DDB6	DDB5	DDB4	DDB3	DDB2	DDB1	DDB0
RESET:	0	0	0	0	0	0	0	0

This register determines the primary direction for each port B pin when functioning as a general-purpose I/O port. DDRB is not in the on-chip map in expanded and peripheral modes. Read and write anytime.

- 0 = Associated pin is a high-impedance input
- 1 = Associated pin is an output

PORTE — Port E Register

\$0008

	Bit 7	6	5	4	3	2	1	Bit 0
Single Chip	PE7	PE6	PE5	PE4	PE3	PE2	PE1	PE0
RESET:	–	–	–	–	–	–	–	–
Alt. Pin Function	DBE	MODB or IPIPE1	MODA or IPIPE0	ECLK	$\overline{\text{LSTRB}}$ or TAGLO	R/ $\overline{\text{W}}$	$\overline{\text{IRQ}}$	$\overline{\text{XIRQ}}$

This register is associated with external bus control signals and interrupt inputs including data bus enable ( $\overline{\text{DBE}}$ ), mode select (MODB/IPIPE1, MODA/IPIPE0), E clock, data size ( $\overline{\text{LSTRB}}$ / $\overline{\text{TAGLO}}$ ), read/write (R/ $\overline{\text{W}}$ ),  $\overline{\text{IRQ}}$ , and  $\overline{\text{XIRQ}}$ . When the associated pin is not used for one of these specific functions, the pin can be used as general-purpose I/O. The port E assignment register (PEAR) selects the function of each pin. DDRE determines the primary direction of each port E pin when configured to be general-purpose I/O.

Some of these pins have software selectable pull-ups ( $\overline{\text{DBE}}$ ,  $\overline{\text{LSTRB}}$ , R/ $\overline{\text{W}}$ , and  $\overline{\text{XIRQ}}$ ). A single control bit enables the pull-ups for all these pins which are configured as inputs.  $\overline{\text{IRQ}}$  always has a pull-up.

This register is not in the map in peripheral mode or expanded modes when the EME bit is set.

Read and write anytime.

## DDRE — Port E Data Direction Register

**\$0009**

	Bit 7	6	5	4	3	2	1	Bit 0
	DDE7	DDE6	DDE5	DDE4	DDE3	DDE2	0	0
RESET:	0	0	0	0	0	0	–	–

This register determines the primary direction for each port E pin configured as general-purpose I/O.

0 = Associated pin is a high-impedance input

1 = Associated pin is an output

PE[1:0] are associated with  $\overline{XIRQ}$  and  $\overline{IRQ}$  and cannot be configured as outputs. These pins can be read regardless of whether the alternate interrupt functions are enabled.

This register is not in the map in peripheral mode and expanded modes while the EME control bit is set.

Read and write anytime.

## PEAR — Port E Assignment Register

**\$000A**

	Bit 7	6	5	4	3	2	1	Bit 0	
	NDBE	0	PIPOE	NECLK	LSTRE	RDWE	0	0	
RESET:	0	–	0	0	0	0	–	–	Normal Expanded
RESET:	0	–	1	0	1	1	–	–	Special Expanded
RESET:	1	–	0	1	0	0	–	–	Peripheral
RESET:	1	–	0	1	0	0	–	–	Normal Single Chip
RESET:	0	–	1	0	1	1	–	–	Special Single Chip

The PEAR register is used to choose between the general-purpose I/O functions and the alternate bus control functions of port E. When an

alternate control function is selected, the associated DDRE bits are overridden.

The reset condition of this register depends on the mode of operation because bus-control signals are needed immediately after reset in some modes.

In normal single-chip mode, no external bus control signals are needed so all of port E is configured for general-purpose I/O.

In special single-chip mode, the E clock is enabled as a timing reference and the other bits of port E are configured for general-purpose I/O.

In normal expanded modes, the reset vector is located in external memory. The E clock may be required for this access but  $R/\overline{W}$  is only needed by the system when there are external writable resources. Therefore in normal expanded modes, only the E clock is configured for its alternate bus control function and the other bits of port E are configured for general-purpose I/O. If the normal expanded system needs any other bus-control signals, PEAR would need to be written before any access that needed the additional signals.

In special expanded modes, IPIPE1, IPIPE0, E,  $R/\overline{W}$ , and  $\overline{LSTRB}$  are configured as bus-control signals.

In peripheral mode, the PEAR register is not accessible for reads or writes.

### NDBE — No Data Bus Enable

Read and write anytime.

0 = PE7 is used for external control of data enables on memories.

1 = PE7 is used for general-purpose I/O.

### PIPOE — Pipe Signal Output Enable

Normal: write once; Special: write anytime except the first time. Read anytime. This bit has no effect in single chip modes.

0 = PE[6:5] are general-purpose I/O.

1 = PE[6:5] are outputs and indicate the state of the instruction queue.



**NECLK — No External E Clock**

In expanded modes, writes to this bit have no effect. E clock is required for de-multiplexing the external address; NECLK will remain zero in expanded modes. NECLK can be written once in normal single chip mode and can be written anytime in special single chip mode. The bit can be read anytime.

0 = PE4 is the external E-clock pin subject to the following limitation: In single-chip modes, PE4 is general-purpose I/O unless NECLK = 0 and either IVIS = 1 or ESTR = 0. A 16-bit write to PEAR:MODE can configure all three bits in one operation.

1 = PE4 is a general-purpose I/O pin.

**LSTRE — Low Strobe ( $\overline{\text{LSTRB}}$ ) Enable**

Normal: write once; Special: write anytime except the first time. Read anytime. This bit has no effect in single-chip modes or normal expanded narrow mode.

0 = PE3 is a general-purpose I/O pin.

1 = PE3 is configured as the  $\overline{\text{LSTRB}}$  bus-control output, provided the MCU is not in single chip or normal expanded narrow modes.

$\overline{\text{LSTRB}}$  is used during external writes. After reset in normal expanded mode,  $\overline{\text{LSTRB}}$  is disabled. If needed, it should be enabled before external writes. External reads do not normally need  $\overline{\text{LSTRB}}$  because all 16 data bits can be driven even if the MCU only needs 8 bits of data.

$\overline{\text{TAGLO}}$  is a shared function of the PE3/ $\overline{\text{LSTRB}}$  pin. In special expanded modes with LSTRE set and the BDM instruction tagging on, a zero at the falling edge of E tags the instruction word low byte being read into the instruction queue.

**RDWE — Read/Write Enable**

Normal: write once; Special: write anytime except the first time. Read anytime. This bit has no effect in single-chip modes.

0 = PE2 is a general-purpose I/O pin.

1 = PE2 is configured as the  $\text{R}/\overline{\text{W}}$  pin. In single chip modes, RDWE has no effect and PE2 is a general-purpose I/O pin.

$R/\overline{W}$  is used for external writes. After reset in normal expanded mode, it is disabled. If needed it should be enabled before any external writes.

**PUCR — Pull Up Control Register**

**\$000C**

	Bit 7	6	5	4	3	2	1	Bit 0
	0	0	0	PUPE	0	0	PUPB	PUPA
RESET:	0	0	0	1	0	0	0	0

These bits select pull-up resistors for any pin in the corresponding port that is currently configured as an input. This register is not in the map in peripheral mode.

Read and write anytime.

**PUPE — Pull-Up Port E Enable**

Pin PE1 always has a pull-up. Pins PE6, PE5, and PE4 never have pull-ups.

0 = Port E pull-ups on PE7, PE3, PE2, and PE0 are disabled.

1 = Enable pull-up devices for port E input pins PE7, PE3, PE2, and PE0.

**PUPB — Pull-Up Port B Enable**

0 = Port B pull-ups are disabled.

1 = Enable pull-up devices for all port B input pins.

This bit has no effect if port B is being used as part of the address/data bus (the pull-ups are inactive).

**PUPA — Pull-Up Port A Enable**

0 = Port A pull-ups are disabled.

1 = Enable pull-up devices for all port A input pins.

This bit has no effect if port A is being used as part of the address/data bus (the pull-ups are inactive).

## RDRIV — Reduced Drive of I/O Lines

**\$000D**

	Bit 7	6	5	4	3	2	1	Bit 0
	0	0	0	0	RDPE	0	RDPB	RDPA
RESET:	0	0	0	0	0	0	0	0

These bits select reduced drive for the associated port pins. This gives reduced power consumption and reduced RFI with a slight increase in transition time (depending on loading). The reduced drive function is independent of which function is being used on a particular port. This register is not in the map in peripheral mode.

Normal: write once; Special: write anytime except the first time. Read anytime.

### RDPE — Reduced Drive of Port E

0 = All port E output pins have full drive enabled.

1 = All port E output pins have reduced drive capability.

### RDPB — Reduced Drive of Port B

0 = All port B output pins have full drive enabled.

1 = All port B output pins have reduced drive capability.

### RDPA — Reduced Drive of Port A

0 = All port A output pins have full drive enabled.

1 = All port A output pins have reduced drive capability.



# Flash EEPROM

---

---

## Contents

Introduction . . . . .	65
Overview . . . . .	66
Flash EEPROM Control Block . . . . .	66
Flash EEPROM Array . . . . .	66
Flash EEPROM Registers. . . . .	67
Operation . . . . .	71
Programming the Flash EEPROM . . . . .	74
Erasing the Flash EEPROM . . . . .	76
Program/Erase Protection Interlocks . . . . .	78
Stop or Wait Mode . . . . .	78
Test Mode . . . . .	79

---

---

## Introduction

The 32K byte Flash EEPROM module for the MC68HC912BD32 serves as electrically erasable and programmable, non-volatile ROM emulation memory. The module can be used for program code that must either execute at high speed or is frequently executed, such as operating system kernels and standard subroutines, or it can be used for static data which is read frequently. The Flash EEPROM is ideal for program storage for single-chip applications allowing for field reprogramming.

---

---

## Overview

The Flash EEPROM array is arranged in a 16-bit configuration and may be read as either bytes, aligned words or misaligned words. Access time is one bus cycle for byte and aligned word access and two bus cycles for misaligned word operations.

The Flash EEPROM module requires an external program/erase voltage ( $V_{FP}$ ) to program or erase the Flash EEPROM array. The external program/erase voltage is provided to the Flash EEPROM module via an external  $V_{FP}$  pin. To prevent damage to the flash array,  $V_{FP}$  should always be greater than or equal to  $V_{DD}-0.5V$ . Programming is by byte or aligned word. The Flash EEPROM module supports bulk erase only.

The Flash EEPROM module has hardware interlocks which protect stored data from accidental corruption. An erase- and program-protected 2K byte block for boot routines is located at \$7800-\$7FFF or \$F800-\$FFFF depending upon the mapped location of the Flash EEPROM array.

---

---

## Flash EEPROM Control Block

A 4-byte register block controls the Flash EEPROM module operation. Configuration information is specified and programmed independently from the contents of the Flash EEPROM array. At reset, the 4-byte register section starts at address \$00F4.

---

---

## Flash EEPROM Array

After reset, the Flash EEPROM array is located from addresses \$8000 to \$FFFF in single-chip mode. In Expanded modes the Flash EEPROM array is located from address \$0000 to \$7FFF, however, it is turned off. The Flash EEPROM can be mapped to an alternate address range. See [Operating Modes](#).

Flash EEPROM Registers

**FEELCK** — Flash EEPROM Lock Control Register **\$00F4**

	Bit 7	6	5	4	3	2	1	Bit 0
	0	0	0	0	0	0	0	LOCK
RESET:	0	0	0	0	0	0	0	0

In normal modes the LOCK bit can only be written once after reset.

**LOCK** — Lock Register Bit

- 0 = Enable write to FEEMCR register
- 1 = Disable write to FEEMCR register

**FEEMCR** — Flash EEPROM Module Configuration Register **\$00F5**

	Bit 7	6	5	4	3	2	1	Bit 0
	0	0	0	0	0	0	0	BOOTP
RESET:	0	0	0	0	0	0	0	1

This register controls the operation of the Flash EEPROM array. BOOTP cannot be changed when the LOCK control bit in the FEELCK register is set or if ENPE in the FEECTL register is set.

**BOOTP** — Boot Protect

The boot block is located at \$7800–\$7FFF or \$F800–\$FFFF depending upon the mapped location of the Flash EEPROM array and mask set (\$7C00–\$7FFF or \$FC00–\$FFFF for 1K byte block).

- 0 = Enable erase and program of 1K byte or 2K byte boot block
- 1 = Disable erase and program of 1K byte or 2K byte boot block

**FEETST** — Flash EEPROM Module Test Register **\$00F6**

	Bit 7	6	5	4	3	2	1	Bit 0
	FSTE	GADR	HVT	FENLV	FDISVFP	VTCK	STRE	MWPR
RESET:	0	0	0	0	0	0	0	0

In normal mode, writes to FEETST control bits have no effect and always read zero. The Flash EEPROM module cannot be placed in test mode inadvertently during normal operation.

FSTE — Stress Test Enable

0 = Disables the gate/drain stress circuitry

1 = Enables the gate/drain stress circuitry

GADR — Gate/Drain Stress Test Select

0 = Selects the drain stress circuitry

1 = Selects the gate stress circuitry

HVT — Stress Test High Voltage Status

0 = High voltage not present during stress test

1 = High voltage present during stress test

FENLV — Enable Low Voltage

0 = Disables low voltage transistor in current reference circuit

1 = Enables low voltage transistor in current reference circuit

FDISVFP — Disable Status  $V_{FP}$  Voltage Lock

When the  $V_{FP}$  pin is below normal programming voltage the Flash module will not allow writing to the LAT bit; the user cannot erase or program the Flash module. The FDISVFP control bit enables writing to the LAT bit regardless of the voltage on the  $V_{FP}$  pin.

0 = Enable the automatic lock mechanism if  $V_{FP}$  is low

1 = Disable the automatic lock mechanism if  $V_{FP}$  is low

VTCK —  $V_T$  Check Test Enable

When VTCK is set, the Flash EEPROM module uses the  $V_{FP}$  pin to control the control gate voltage; the sense amp time-out path is disabled. This allows for indirect measurements of the bit cells program and erase threshold. If  $V_{FP} < V_{ZBRK}$  (breakdown voltage) the control gate will equal the  $V_{FP}$  voltage.

If  $V_{FP} > V_{ZBRK}$  the control gate will be regulated by the following equation:

$$V_{\text{control gate}} = V_{ZBRK} + 0.44 \times (V_{FP} - V_{ZBRK})$$

0 =  $V_T$  test disable

1 =  $V_T$  test enable



## STRE — Spare Test Row Enable

The spare test row consists of one Flash EEPROM array row. The reserved word at location 31 contains production test information which must be maintained through several erase cycles. When STRE is set, the decoding for the spare test row overrides the address lines which normally select the other rows in the array.

- 0 = LIB accesses are to the Flash EEPROM array
- 1 = Spare test row in array enabled if SMOD is active

## MWPR — Multiple Word Programming

Used primarily for testing, if MPWR = 1, the two least-significant address lines ADDR[1:0] will be ignored when programming a Flash EEPROM location. The word location addressed if ADDR[1:0] = 00, along with the word location addressed if ADDR[1:0] = 10, will both be programmed with the same word data from the programming latches. This bit should not be changed during programming.

- 0 = Multiple word programming disabled
- 1 = Program 32 bits of data

## FEECTL — Flash EEPROM Control Register

**\$00F7**

	Bit 7	6	5	4	3	2	1	Bit 0
	0	0	0	FEESWAI	SVFP	ERAS	LAT	ENPE
RESET:	0	0	0	0	0	0	0	0

This register controls the programming and erasure of the Flash EEPROM.

## FEESWAI — Flash EEPROM Stop in Wait Control

- 0 = Do not halt Flash EEPROM clock when the part is in wait mode.
- 1 = Halt Flash EEPROM clock when the part is in wait mode.

**NOTE:** *The FEESWAI bit cannot be asserted if the interrupt vector resides in the Flash EEPROM array.*

## SVFP — Status V<sub>FP</sub> Voltage

SVFP is a read only bit.

- 0 = Voltage of V<sub>FP</sub> pin is below normal programming voltage levels
- 1 = Voltage of V<sub>FP</sub> pin is above normal programming voltage levels

**ERAS — Erase Control**

This bit can be read anytime or written when ENPE = 0. When set, all locations in the array will be erased at the same time. The boot block will be erased only if BOOTP = 0. This bit also affects the result of attempted array reads. See [Table 1](#) for more information. Status of ERAS cannot change if ENPE is set.

- 0 = Flash EEPROM configured for programming
- 1 = Flash EEPROM configured for erasure

**LAT — Latch Control**

This bit can be read anytime or written when ENPE = 0. When set, the Flash EEPROM is configured for programming or erasure and, upon the next valid write to the array, the address and data will be latched for the programming sequence. See [Table 1](#) for the effects of LAT on array reads. A high voltage detect circuit on the V<sub>FP</sub> pin will prevent assertion of the LAT bit when the programming voltage is at normal levels.

- 0 = Programming latches disabled
- 1 = Programming latches enabled

**ENPE — Enable Programming/Erase**

- 0 = Disables program/erase voltage to Flash EEPROM
- 1 = Applies program/erase voltage to Flash EEPROM

ENPE can be asserted only after LAT has been asserted and a write to the data and address latches has occurred. If an attempt is made to assert ENPE when LAT is negated, or if the latches have not been written to after LAT was asserted, ENPE will remain negated after the write cycle is complete.

The LAT, ERAS and BOOTP bits cannot be changed when ENPE is asserted. A write to FEECTL may only affect the state of ENPE. Attempts to read a Flash EEPROM array location in the Flash EEPROM module while ENPE is asserted will not return the data addressed. See [Table 1](#) for more information.

Flash EEPROM module control registers may be read or written while ENPE is asserted. If ENPE is asserted and LAT is negated on the same write access, no programming or erasure will be performed.

**Table 1 Effects of ENPE, LAT and ERAS on Array Reads**

ENPE	LAT	ERAS	Result of Read
0	0	–	Normal read of location addressed
0	1	0	Read of location being programmed
0	1	1	Normal read of location addressed
1	–	–	Read cycle is ignored

---



---

## Operation

The Flash EEPROM can contain program and data. On reset, it can operate as a bootstrap memory to provide the CPU with internal initialization information during the reset sequence.

### Bootstrap Operation Single-Chip Mode

After reset, the CPU controlling the system will begin booting up by fetching the first program address from address \$FFFE.

### Normal Operation

The Flash EEPROM allows a byte or aligned word read/write in one bus cycle. Misaligned word read/write require an additional bus cycle. The Flash EEPROM array responds to read operations only. Write operations are ignored.

### Program/Erase Operation

An unprogrammed Flash EEPROM bit has a logic state of one. A bit must be programmed to change its state from one to zero. Erasing a bit returns it to a logic one. The Flash EEPROM has a minimum program/erase life of 100 cycles. Programming or erasing the Flash EEPROM is accomplished by a series of control register writes and a write to a set of programming latches.

Programming is restricted to a single byte or aligned word at a time as determined by internal signal SZ8 and ADDR[0]. The Flash EEPROM must first be completely erased prior to programming final data values. It is possible to program a location in the Flash EEPROM without erasing

the entire array if the new value does not require the changing of bit values from zero to one.

### *Read/Write Accesses During Program/Erase*

During program or erase operations, read and write accesses may be different from those during normal operation and are affected by the state of the control bits in the Flash EEPROM control register (FEECTL). The next write to any valid address to the array after LAT is set will cause the address and data to be latched into the programming latches. Once the address and data are latched, write accesses to the array will be ignored while LAT is set. Writes to the control registers will occur normally.

### *Program/Erase Verification*

When programming or erasing the Flash EEPROM array, a special verification method is required to ensure that the program/erase process is reliable, and also to provide the longest possible life expectancy. This method requires stopping the program/erase sequence at periods of  $t_{PPULSE}$  ( $t_{EPULSE}$  for erasing) to determine if the Flash EEPROM is programmed/erased. After the location reaches the proper value, it must continue to be programmed/erased with additional margin pulses to ensure that it will remain programmed/erased. Failure to provide the margin pulses could lead to corrupted or unreliable data.

### *Program/Erase Sequence*

To begin a program or erase sequence the external  $V_{FP}$  voltage must be applied and stabilized. The ERAS bit must be set or cleared, depending on whether a program sequence or an erase sequence is to occur. The LAT bit will be set to cause any subsequent data written to a valid address within the Flash EEPROM to be latched into the programming address and data latches. The next Flash array write cycle must be either to the location that is to be programmed if a programming sequence is being performed, or, if erasing, to any valid Flash EEPROM array location. Writing the new address and data information to the Flash EEPROM is followed by assertion of ENPE to turn on the program/erase voltage to program/erase the new location(s). The LAT bit must be asserted and the address and data latched to allow the setting of the ENPE control bit. If the data and address have not been latched, an attempt to assert ENPE will be ignored and ENPE will remain negated after the write cycle to FEECTL is completed. The LAT bit must remain

asserted and the ERAS bit must remain in its current state as long as ENPE is asserted. A write to the LAT bit to clear it while ENPE is set will be ignored. That is, after the write cycle, LAT will remain asserted. Likewise, an attempt to change the state of ERAS will be ignored and the state of the ERAS bit will remain unchanged.

The programming software is responsible for all timing during a program sequence. This includes the total number of program pulses ( $n_{PP}$ ), the length of the program pulse ( $t_{PPULSE}$ ), the program margin pulses ( $p_m$ ) and the delay between turning off the high voltage and verifying the operation ( $t_{VPROG}$ ).

The erase software is responsible for all timing during an erase sequence. This includes the total number of erase pulses ( $e_m$ ), the length of the erase pulse ( $t_{EPULSE}$ ), the erase margin pulse or pulses, and the delay between turning off the high voltage and verifying the operation ( $t_{VERASE}$ ).

Software also controls the supply of the proper program/erase voltage to the  $V_{FP}$  pin, and should be at the proper level before ENPE is set during a program/erase sequence.

A program/erase cycle should not be in progress when starting another program/erase, or while attempting to read from the array.

**NOTE:** *Although clearing ENPE disables the program/erase voltage ( $V_{FP}$ ) from the  $V_{FP}$  pin to the array, care must be taken to ensure that  $V_{FP}$  is at  $V_{DD}$  whenever programming/erasing is not in progress. Not doing so could damage the part. Ensuring that  $V_{FP}$  is always greater or equal to  $V_{DD}$  can be accomplished by controlling the  $V_{FP}$  power supply with the programming software via an output pin. Alternatively, all programming and erasing can be done prior to installing the device on an application circuit board which can always connect  $V_{FP}$  to  $V_{DD}$ . Programming can also be accomplished by plugging the board into a special programming fixture which provides program/erase voltage to the  $V_{FP}$  pin.*

---



---

## Programming the Flash EEPROM

Programming the Flash EEPROM is accomplished by the following sequence. The  $V_{FP}$  pin voltage must be at the proper level prior to executing step 4 the first time.

1. Apply program/erase voltage to the  $V_{FP}$  pin.
2. Clear ERAS and set the LAT bit in the FEECTL register to establish program mode and enable programming address and data latches.
3. Write data to a valid address. The address and data is latched. If BOOTP is asserted, an attempt to program an address in the boot block will be ignored.
4. Apply programming voltage by setting ENPE.
5. Delay for one programming pulse ( $t_{PPULSE}$ ).
6. Remove programming voltage by clearing ENPE.
7. Delay while high voltage is turning off ( $t_{VPROG}$ ).
8. Read the address location to verify that it has been programmed
9. If the location is not programmed, repeat steps 4 through 7 until the location is programmed or until the specified maximum number of program pulses has been reached ( $n_{PP}$ )
10. If the location is programmed, repeat the same number of pulses as required to program the location. This provides 100% program margin.
11. Read the address location to verify that it remains programmed.
12. Clear LAT.
13. If there are more locations to program, repeat steps 2 through 10.
14. Turn off  $V_{FP}$  (reduce voltage on  $V_{FP}$  pin to  $V_{DD}$ ).

The flowchart in [Figure 7](#) demonstrates the recommended programming sequence.

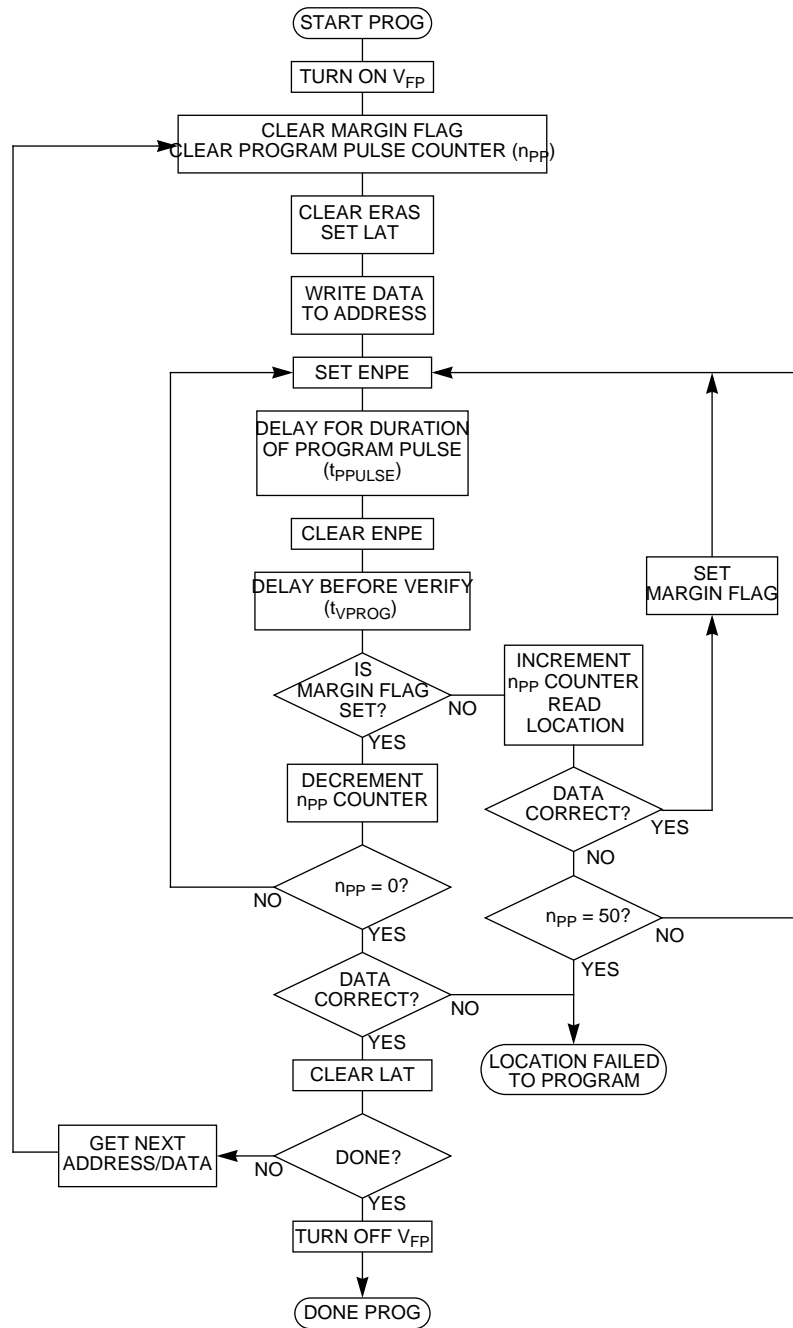

Figure 7 Program Sequence Flow

---



---

## Erasing the Flash EEPROM

The following sequence demonstrates the recommended procedure for erasing the Flash EEPROM. The  $V_{FP}$  pin voltage must be at the proper level prior to executing step 4 the first time.

1. Turn on  $V_{FP}$  (apply program/erase voltage to the  $V_{FP}$  pin).
2. Set the LAT bit and ERAS bit to configure the Flash EEPROM for erasing.
3. Write to any valid address in the Flash array. This allows the erase voltage to be turned on; the data written and the address written are not important. The boot block will be erased only if the control bit BOOTP is negated.
4. Apply erase voltage by setting ENPE.
5. Delay for a single erase pulse ( $t_{EPULSE}$ ).
6. Remove erase voltage by clearing ENPE.
7. Delay while high voltage is turning off ( $t_{VERASE}$ ).
8. Read the entire array to ensure that the Flash EEPROM is erased.
9. If all of the Flash EEPROM locations are not erased, repeat steps 4 through 7 until either the remaining locations are erased, or until the maximum erase pulses have been applied ( $n_{EP}$ ).
10. If all of the Flash EEPROM locations are erased, repeat the same number of pulses as required to erase the array. This provides 100% erase margin.
11. Read the entire array to ensure that the Flash EEPROM is erased.
12. Clear LAT.
13. Turn off  $V_{FP}$  (reduce voltage on  $V_{FP}$  pin to  $V_{DD}$ ).

The flowchart in [Figure 8](#) demonstrates the recommended erase sequence.



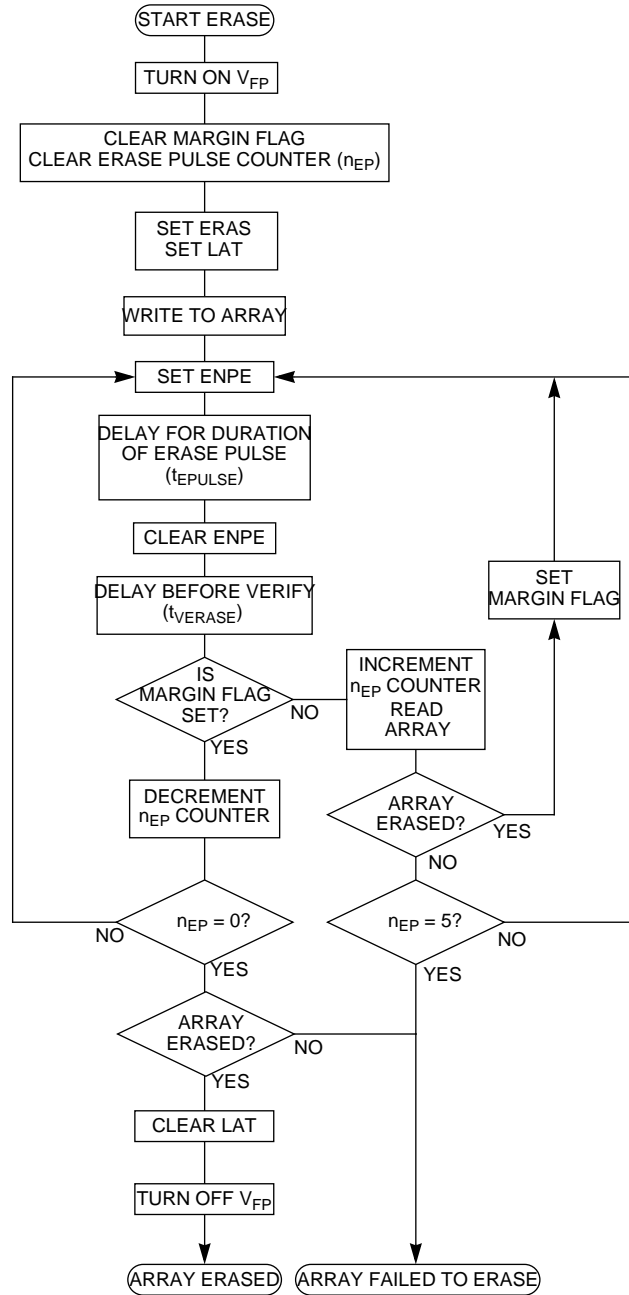

Figure 8 Erase Sequence Flow

---

---

## Program/Erase Protection Interlocks

The Flash EEPROM program and erase mechanisms provide maximum protection from accidental programming or erasure.

The voltage required to program/erase the Flash EEPROM ( $V_{FP}$ ) is supplied via an external pin. If  $V_{FP}$  is not present, no programming/erasing will occur. Furthermore, the program/erase voltage will not be applied to the Flash EEPROM unless turned on by setting a control bit (ENPE). The ENPE bit may not be set unless the programming address and data latches have been written previously with a valid address. The latches may not be written unless enabled by setting a control bit (LAT). The LAT and ENPE control bits must be written on separate writes to the control register (FEECTL) and must be separated by a write to the programming latches. The ERAS and LAT bits are also protected when ENPE is set. This prevents inadvertent switching between erase/program mode and also prevents the latched data and address from being changed after a program cycle has been initiated.

---

---

## Stop or Wait Mode

When stop or wait commands are executed, the MCU puts the Flash EEPROM in stop or wait mode. In these modes the Flash module will cease erasure or programming immediately. It is advised not to enter stop or wait modes when programming the Flash array.

**CAUTION:** *The Flash EEPROM module is not able to recover from STOP without a 1 microsecond delay. This cannot be controlled internal to the MCU. Therefore, do not attempt to recover from STOP with an interrupt. Use RESET to recover from a STOP mode executed from Flash EEPROM. Recovery from a STOP instruction executed from EEPROM and RAM operate normally.*

---

---

## Test Mode

The Flash EEPROM has some special test functions which are only accessible when the device is in test mode. Test mode is indicated to the Flash EEPROM module when the SMOD line on the LIB is asserted. When SMOD is asserted, the special test control bits may be accessed via the LIB to invoke the special test functions in the Flash EEPROM module. When SMOD is not asserted, writes to the test control bits have no effect and all bits in the test register FEETST will be cleared. This ensures that Flash EEPROM test mode cannot be invoked inadvertently during normal operation.

Note that the Flash EEPROM module will operate normally, even if SMOD is asserted, until a special test function is invoked. The test mode adds additional features over normal mode which allow the tests to be performed even after the device is installed in the final product.



---

---

## Contents

Introduction . . . . .	81
EEPROM Programmer's Model . . . . .	82
EEPROM Control Registers . . . . .	83

---

---

## Introduction

The MC68HC912BD32 EEPROM nonvolatile memory is arranged in a 16-bit configuration. The EEPROM array may be read as either bytes, aligned words or misaligned words. Access times is one bus cycle for byte and aligned word access and two bus cycles for misaligned word operations.

Programming is by byte or aligned word. Attempts to program or erase misaligned words will fail. Only the lower byte will be latched and programmed or erased. Programming and erasing of the user EEPROM can be done in all modes.

Each EEPROM byte or aligned word must be erased before programming. The EEPROM module supports byte, aligned word, row (32 bytes) or bulk erase, all using the internal charge pump. Bulk erasure of odd and even rows is also possible in test modes; the erased state is \$FF. The EEPROM module has hardware interlocks which protect stored data from corruption by accidentally enabling the program/erase voltage. Programming voltage is derived from the internal  $V_{DD}$  supply with an internal charge pump.

---

---

## EEPROM Programmer's Model

The EEPROM module consists of two separately addressable sections. The first is a four-byte memory mapped control register block used for control, testing and configuration of the EEPROM array. The second section is the EEPROM array itself.

At reset, the four-byte register section starts at address \$00F0 and the EEPROM array is located from addresses \$0D00 to \$0FFF. For information on re-mapping the register block and EEPROM address space, refer to [Operating Modes](#).

Read/write access to the memory array section can be enabled or disabled by the EEON control bit in the INITEE register. This feature allows the access of memory mapped resources that have lower priority than the EEPROM memory array. EEPROM control registers can be accessed and EEPROM locations may be programmed or erased regardless of the state of EEON.

Using the normal EEPROG control, it is possible to continue program/erase operations during WAIT. For lowest power consumption during WAIT, stop program/erase by turning off EEPGM.

If the STOP mode is entered during programming or erasing, program/erase voltage will be automatically turned off and the RC clock (if enabled) is stopped. However, the EEPGM control bit will remain set. When STOP mode is terminated, the program/erase voltage will be automatically turned back on if EEPGM is set.

At low bus frequencies, the RC clock must be turned on for program/erase.

The EEPROM module contains an extra byte called SHADOW byte which is loaded at reset into the EEMCR register.

To program the SHADOW byte, when in special modes (SMODN=0), the NOSHB bit in EEMCR register must be cleared. Normal programming routines are used to program the SHADOW byte which becomes accessible at address \$0FC0 when NOSHB is cleared. At the next reset the SHADOW byte data is loaded into the EEMCR.

The SHADOW byte can be protected from being programmed or erased by setting the SHPROT bit of EEPROT register.

---



---

## EEPROM Control Registers

### EEMCR — EEPROM Module Configuration

\$00F0

	Bit 7	6	5	4	3	2	1	Bit 0
	NOBDML	NOSHB	RESERVED <sup>(1)</sup>	RESERVED <sup>(1)</sup>	1	EESWAI	PROTLCK	EERC
RESET:	— <sup>(2)</sup>	—	—	—	1	1	0	0

1. Bits 4 and 5 have test functions and should not be programmed.
2. Loaded from SHADOW byte.

Bits[7:4] are loaded at reset from the EEPROM SHADOW byte.

**NOTE:** *The bits 5 and 4 are reserved for test purposes. These locations in SHADOW byte should not be programmed otherwise some locations of regular EEPROM array will be no more visible.*

#### NOBDML — Background Debug Mode Lockout Disable

- 0 = The BDM lockout is enabled.
- 1 = The BDM lockout is disabled.

Loaded from SHADOW byte at reset.

Read anytime. Write anytime in special modes (SMODN=0).

#### NOSHB — SHADOW Byte Disable

- 0 = The SHADOW byte enabled and accessible at address \$0FC0.
- 1 = Regular EEPROM array at address \$0FC0.

Loaded from SHADOW byte at reset.

Read anytime. Write anytime in special modes (SMODN=0).

When NOSHB cleared, the regular EEPROM array byte at address \$0FC0 is no more visible. The SHADOW byte is accessed instead for both read and program/erase operations. BULK, ODD and EVEN program/erase only applies if SHADOW byte is enabled.

**NOTE:** *The bit 6 in SHADOW byte should not be programmed in order to have the full EEPROM array visible.*

EESWAI — EEPROM Stops in Wait Mode

- 0 = The module is not affected during WAIT mode
- 1 = The module ceases to be clocked during WAIT mode

Read and write anytime.

**NOTE:** *The EESWAI bit should be cleared if the WAIT mode vectors are mapped in the EEPROM array.*

PROTLCK — Block Protect Write Lock

- 0 = Block protect bits and bulk erase protection bit can be written
- 1 = Block protect bits are locked

Read anytime. Write once in normal modes (SMODN = 1), set and clear any time in special modes (SMODN = 0).

EERC — EEPROM Charge Pump Clock

- 0 = System clock is used as clock source for the internal charge pump. Internal RC oscillator is stopped.
- 1 = Internal RC oscillator drives the charge pump. The RC oscillator is required when the system bus clock is lower than  $f_{PROG}$ .

Read and write anytime.

EEPROT — EEPROM Block Protect

**\$00F1**

	Bit 7	6	5	4	3	2	1	Bit 0
RESET:	1	1	1	1	1	1	1	1

Prevents accidental writes to EEPROM. Read anytime. Write anytime if EEPGM = 0 and PROTLCK = 0.

SHPROT — SHADOW Byte Protection

- 0 = The SHADOW byte can be programmed and erased.
- 1 = The SHADOW byte is protected from being programmed and erased.

BPROT[4:0] — EEPROM Block Protection

- 0 = Associated EEPROM block can be programmed and erased.
- 1 = Associated EEPROM block is protected from being programmed and erased.



**Table 15 768-byte EEPROM Block Protection**

Bit Name	Block Protected	Block Size
BPROT4	\$0D00 to \$0DFF	256 Bytes
BPROT3	\$0E00 to \$0EFF	256 Bytes
BPROT2	\$0F00 to \$0F7F	128 Bytes
BPROT1	\$0F80 to \$0FBF	64 Bytes
BPROT0	\$0FC0 to \$0FFF	64 Bytes

**EETST — EEPROM Test**

**\$00F2**

	Bit 7	6	5	4	3	2	1	Bit 0
	EEODD	EEVEN	MARG	EECPD	EECPRD	0	EECPM	0
RESET:	0	0	0	0	0	0	0	0

Read anytime. Write in special modes only (SMODN = 0). These bits are used for test purposes only. In normal modes the bits are forced to zero.

**EEODD — Odd Row Programming**

- 0 = Odd row bulk programming/erasing is disabled.
- 1 = Bulk program/erase all odd rows.

**EEVEN — Even Row Programming**

- 0 = Even row bulk programming/erasing is disabled.
- 1 = Bulk program/erase all even rows.

**MARG — Program and Erase Voltage Margin Test Enable**

- 0 = Normal operation.
- 1 = Program and Erase Margin test.

This bit is used to evaluate the program/erase voltage margin.

**EECPD — Charge Pump Disable**

- 0 = Charge pump is turned on during program/erase.
- 1 = Disable charge pump.

**EECPRD — Charge Pump Ramp Disable**

Known to enhance write/erase endurance of EEPROM cells.

- 0 = Charge pump is turned on progressively during program/erase.
- 1 = Disable charge pump controlled ramp up.

EECPM — Charge Pump Monitor Enable

0 = Normal operation.

1 = Output the charge pump voltage on the  $\overline{IRQ}/V_{PP}$  pin.

EEPROG — EEPROM Control

\$00F3

	Bit 7	6	5	4	3	2	1	Bit 0
	BULKP	0	0	BYTE	ROW	ERASE	EELAT	EEPGM
RESET:	1	0	0	0	0	0	0	0

BULKP — Bulk Erase Protection

0 = EEPROM can be bulk erased.

1 = EEPROM is protected from being bulk or row erased.

Read anytime. Write anytime if EEPGM = 0 and PROTLCK = 0.

BYTE — Byte and Aligned Word Erase

0 = Bulk or row erase is enabled.

1 = One byte or one aligned word erase only.

Read anytime. Write anytime if EEPGM = 0.

ROW — Row or Bulk Erase (when BYTE = 0)

0 = Erase entire EEPROM array.

1 = Erase only one 32-byte row.

Read anytime. Write anytime if EEPGM = 0.

BYTE and ROW have no effect when ERASE = 0

**Table 16 Erase Selection**

BYTE	ROW	Block size
0	0	Bulk erase entire EEPROM array
0	1	Row erase 32 bytes
1	0	Byte or aligned word erase
1	1	Byte or aligned word erase

If BYTE = 1 and test mode is not enabled, only the location specified by the address written to the programming latches will be erased. The operation will be a byte or an aligned word erase depending on the size of written data.

ERASE — Erase Control

0 = EEPROM configuration for programming.

1 = EEPROM configuration for erasure.

Read anytime. Write anytime if EEPGM = 0.

Configures the EEPROM for erasure or programming.

When test mode is not enabled and unless BULKP is set, erasure is by byte, aligned word, row or bulk.

**EELAT — EEPROM Latch Control**

0 = EEPROM set up for normal reads.

1 = EEPROM address and data bus latches set up for programming or erasing.

Read anytime. Write anytime if EEPGM = 0.

BYTE, ROW, ERASE and EELAT bits can be written simultaneously or in any sequence.

**EEPGM — Program and Erase Enable**

0 = Disables program/erase voltage to EEPROM.

1 = Applies program/erase voltage to EEPROM.

The EEPGM bit can be set only after EELAT has been set. When EELAT and EEPGM are set simultaneously, EEPGM remains clear but EELAT is set.

The BULKP, BYTE, ROW, ERASE and EELAT bits cannot be changed when EEPGM is set. To complete a program or erase, two successive writes to clear EEPGM and EELAT bits are required before reading the programmed data. A write to an EEPROM location has no effect when EEPGM is set. Latched address and data cannot be modified during program or erase.

A program or erase operation should follow the sequence below:

1. Write BYTE, ROW and ERASE to the desired value, write EELAT = 1
2. Write a byte or an aligned word to an EEPROM address
3. Write EEPGM = 1
4. Wait for programming ( $t_{\text{PROG}}$ ) or erase ( $t_{\text{erase}}$ ) delay time
5. Write EEPGM = 0
6. Write EELAT = 0

It is possible to program/erase more bytes or words without intermediate EEPROM reads, by jumping from step 5 to step 2.



# Resets and Interrupts

---

---

## Contents

Introduction . . . . .	89
Exception Priority . . . . .	89
Maskable interrupts . . . . .	90
Interrupt Control and Priority Registers . . . . .	92
Resets . . . . .	93
Effects of Reset . . . . .	94
Register Stacking . . . . .	96

---

---

## Introduction

CPU12 exceptions include resets and interrupts. Each exception has an associated 16-bit vector, which points to the memory location where the routine that handles the exception is located. Vectors are stored in the upper 128 bytes of the standard 64K byte address map.

The six highest vector addresses are used for resets and non-maskable interrupt sources. The remainder of the vectors are used for maskable interrupts, and all must be initialized to point to the address of the appropriate service routine.

---

---

## Exception Priority

A hardware priority hierarchy determines which reset or interrupt is serviced first when simultaneous requests are made. Six sources are not maskable. The remaining sources are maskable, and any one of them can be given priority over other maskable interrupts.

The priorities of the non-maskable sources are:

1. POR or  $\overline{\text{RESET}}$  pin
2. Clock monitor reset
3. COP watchdog reset
4. Unimplemented instruction trap
5. Software interrupt instruction (SWI)
6.  $\overline{\text{XIRQ}}$  signal (if X bit in CCR = 0)

---

---

## Maskable interrupts

Maskable interrupt sources include on-chip peripheral systems and external interrupt service requests. Interrupts from these sources are recognized when the global interrupt mask bit (I) in the CCR is cleared. The default state of the I bit out of reset is one, but it can be written at any time.

Interrupt sources are prioritized by default but any one maskable interrupt source may be assigned the highest priority by means of the HPRIO register. The relative priorities of the other sources remain the same.

An interrupt that is assigned highest priority is still subject to global masking by the I bit in the CCR, or by any associated local bits. Interrupt vectors are not affected by priority assignment. HPRIO can only be written while the I bit is set (interrupts inhibited). [Table 17](#) lists interrupt sources and vectors in default order of priority.

### Table 17 Interrupt Vector Map

Vector Address	Interrupt Source	CCR Mask	Local Enable Register (Bit)	HPRIO Value to Elevate
\$FFFE, \$FFFF	Reset	none	none	–
\$FFFC, \$FFFD	COP Clock Monitor Fail Reset	none	COPCTL (CME, FCME)	–
\$FFFA, \$FFFB	COP Failure Reset	none	COP rate selected	–
\$FFF8, \$FFF9	Unimplemented Instruction Trap	none	none	–
\$FFF6, \$FFF7	SWI	none	none	–
\$FFF4, \$FFF5	XIRQ	X bit	none	–
\$FFF2, \$FFF3	IRQ	I bit	INTCR (IRQEN)	\$F2
\$FFF0, \$FFF1	Real Time Interrupt	I bit	RTICTL (RTIE)	\$F0
\$FFEE, \$FFEF	Timer Channel 0	I bit	TMSK1 (C0I)	\$EE
\$FFEC, \$FFED	Timer Channel 1	I bit	TMSK1 (C1I)	\$EC
\$FFEA, \$FFEB	Timer Channel 2	I bit	TMSK1 (C2I)	\$EA
\$FFE8, \$FFE9	Timer Channel 3	I bit	TMSK1 (C3I)	\$E8
\$FFE6, \$FFE7	Timer Channel 4	I bit	TMSK1 (C4I)	\$E6
\$FFE4, \$FFE5	Timer Channel 5	I bit	TMSK1 (C5I)	\$E4
\$FFE2, \$FFE3	Timer Channel 6	I bit	TMSK1 (C6I)	\$E2
\$FFE0, \$FFE1	Timer Channel 7	I bit	TMSK1 (C7I)	\$E0
\$FFDE, \$FFDF	Timer Overflow	I bit	TMSK2 (TOI)	\$DE
\$FFDC, \$FFDD	Pulse Accumulator Overflow	I bit	PACTL (PAOVI)	\$DC
\$FFDA, \$FFDB	Pulse Accumulator Input Edge	I bit	PACTL (PAI)	\$DA
\$FFD8, \$FFD9	SPI Serial Transfer Complete	I bit	SP0CR1 (SPIE)	\$D8
\$FFD6, \$FFD7	SCI 0	I bit	SC0CR2 (TIE, TCIE, RIE, ILIE)	\$D6
\$FFD4, \$FFD5	Reserved	I bit		\$D4
\$FFD2, \$FFD3	ATD	I bit	ATDCTL2 (ASCIE)	\$D2
\$FFD0, \$FFD1	Receive Fifo	I bit	RIER (RCVFIE)	\$D0
\$FFCA-\$FFCF	Reserved	I bit		\$CA-\$CF
\$FFC8, \$FFC9	SBI Receive	I bit	RIER (RXIE)	\$C8
\$FFC6, \$FFC7	SBI Synchronization	I bit	RIER (SYNAIE,SYNNIE)	\$C6
\$FFC4, \$FFC5	SBI General Interrupt	I bit	GIER (TXIE, OVRNIE, ERRIE, SYNEIE, SYNLIE, ILLPIE, LOCKIE, WAKEIE)	\$C4
\$FF80-\$FFC3	Reserved	I bit		\$80-\$C3

Interrupt Control and Priority Registers

INTCR — Interrupt Control Register

\$001E

	Bit 7	6	5	4	3	2	1	Bit 0
	IRQE	IRQEN	DLY	0	0	0	0	0
RESET:	0	1	1	0	0	0	0	0

IRQE —  $\overline{\text{IRQ}}$  Select Edge Sensitive Only

0 =  $\overline{\text{IRQ}}$  configured for low-level recognition.

1 =  $\overline{\text{IRQ}}$  configured to respond only to falling edges (on pin PE1/ $\overline{\text{IRQ}}$ ).

IRQE can be read anytime and written once in normal modes. In special modes, IRQE can be read anytime and written anytime, except the first write is ignored.

IRQEN — External  $\overline{\text{IRQ}}$  Enable

The  $\overline{\text{IRQ}}$  pin has an internal pull-up.

0 = External  $\overline{\text{IRQ}}$  pin disconnected from interrupt logic

1 = External  $\overline{\text{IRQ}}$  pin connected to interrupt logic

IRQEN can be read and written anytime in all modes.

DLY — Enable Oscillator Start-up Delay on Exit from STOP

The delay time of about 4096 cycles is based on the E clock rate.

0 = No stabilization delay imposed on exit from STOP mode. A stable external oscillator must be supplied.

1 = Stabilization delay is imposed before processing resumes after STOP.

DLY can be read anytime and written once in normal modes. In special modes, DLY can be read and written anytime.



**HPRIO** — Highest Priority I Interrupt

**\$001F**

	Bit 7	6	5	4	3	2	1	Bit 0
	1	1	PSEL5	PSEL4	PSEL3	PSEL2	PSEL1	0
RESET:	1	1	1	1	0	0	1	0

Write only if I mask in CCR = 1 (interrupts inhibited). Read anytime.

To give a maskable interrupt source highest priority, write the low byte of the vector address to the HPRIO register. For example, writing \$F0 to HPRIO would assign highest maskable interrupt priority to the real-time interrupt timer (\$FFF0). If an unimplemented vector address or a non-I-masked vector address (value higher than \$F2) is written, then  $\overline{IRQ}$  will be the default highest priority interrupt.

**Resets**

There are four possible sources of reset. Power-on reset (POR), and external reset on the  $\overline{RESET}$  pin share the normal reset vector. The computer operating properly (COP) reset and the clock monitor reset each has a vector. Entry into reset is asynchronous and does not require a clock but the MCU cannot sequence out of reset without a system clock.

**Power-On Reset**

A positive transition on  $V_{DD}$  causes a power-on reset (POR). An external voltage level detector, or other external reset circuits, are the usual source of reset in a system. The POR circuit only initializes internal circuitry during cold starts and cannot be used to force a reset as system voltage drops.

**External Reset**

The CPU distinguishes between internal and external reset conditions by sensing whether the reset pin rises to a logic one in less than eight E-clock cycles after an internal device releases reset. When a reset condition is sensed, the  $\overline{RESET}$  pin is driven low by an internal device for about 16 E-clock cycles, then released. Eight E-clock cycles later it is sampled. If the pin is still held low, the CPU assumes that an external

reset has occurred. If the pin is high, it indicates that the reset was initiated internally by either the COP system or the clock monitor.

To prevent a COP or clock monitor reset from being detected during an external reset, hold the reset pin low for at least 32 cycles. An external RC power-up delay circuit on the reset pin is not recommended — circuit charge time can cause the MCU to misinterpret the type of reset that has occurred.

### COP Reset

The MCU includes a computer operating properly (COP) system to help protect against software failures. When COP is enabled, software must write \$55 and \$AA (in this order) to the COPRST register in order to keep a watchdog timer from timing out. Other instructions may be executed between these writes. A write of any value other than \$55 or \$AA or software failing to execute the sequence properly causes a COP reset to occur.

### Clock Monitor Reset

If clock frequency falls below a predetermined limit when the clock monitor is enabled, a reset occurs.

---

---

## Effects of Reset

When a reset occurs, MCU registers and control bits are changed to known start-up states, as follows.

### Operating Mode and Memory Map

Operating mode and default memory mapping are determined by the states of the BKGD, MODA, and MODB pins during reset. The SMODN, MODA, and MODB bits in the MODE register reflect the status of the mode-select inputs at the rising edge of reset. Operating mode and default maps can subsequently be changed according to strictly defined rules.

Clock and Watchdog Control Logic	The COP watchdog system is enabled, with the CR [2:0] bits set for the shortest duration time-out. The clock monitor is disabled. The RTIF flag is cleared and automatic hardware interrupts are masked. The rate control bits are cleared, and must be initialized before the RTI system is used. The DLY control bit is set to specify an oscillator start-up delay upon recovery from STOP mode.
Interrupts	PSEL is initialized in the HPRIO register with the value \$F2, causing the external $\overline{\text{IRQ}}$ pin to have the highest I-bit interrupt priority. The $\overline{\text{IRQ}}$ pin is configured for level-sensitive operation (for wired-OR systems). However, the interrupt mask bits in the CPU12 CCR are set to mask X and I related interrupt requests.
Parallel I/O	If the MCU comes out of reset in an expanded mode, port A and port B are used for the multiplexed address/data bus and port E pins are normally used to control the external bus (operation of port E pins can be affected by the PEAR register). If the MCU comes out of reset in a single-chip mode, all ports are configured as general-purpose high-impedance inputs. Port S, port T, port DLC, port P, and port AD are all configured as general-purpose inputs.
Central Processing Unit	After reset, the CPU fetches a vector from the appropriate address, then begins executing instructions. The stack pointer and other CPU registers are indeterminate immediately after reset. The CCR X and I interrupt mask bits are set to mask any interrupt requests. The S bit is also set to inhibit the STOP instruction.
Memory	After reset, the internal register block is located at \$0000–\$01FF, the register-following space is at \$0200–\$03FF, and RAM is at \$0800–\$0BFF. EEPROM is located at \$0D00–\$0FFF. Flash EEPROM is located at \$8000–\$FFFF in single-chip modes and at \$0000–\$7FFF (but disabled) in expanded modes.
Other Resources	The timer, serial communications interface (SCI), serial peripheral interface (SPI), Byteflight™, pulse-width modulator (PWM), and analog-to-digital converter (ATD) are off after reset.

---



---

## Register Stacking

Once enabled, an interrupt request can be recognized at any time after the I bit in the CCR is cleared. When an interrupt service request is recognized, the CPU responds at the completion of the instruction being executed. Interrupt latency varies according to the number of cycles required to complete the instruction. Some of the longer instructions can be interrupted and will resume normally after servicing the interrupt.

When the CPU begins to service an interrupt, the instruction queue is cleared, the return address is calculated, and then it and the contents of the CPU registers are stacked as shown in [Table 18](#).

**Table 18 Stacking Order on Entry to Interrupts**

Memory Location	CPU Registers
SP – 2	RTN <sub>H</sub> : RTN <sub>L</sub>
SP – 4	Y <sub>H</sub> : Y <sub>L</sub>
SP – 6	X <sub>H</sub> : X <sub>L</sub>
SP – 8	B : A
SP – 9	CCR

After the CCR is stacked, the I bit (and the X bit, if an  $\overline{\text{XIRQ}}$  interrupt service request is pending) is set to prevent other interrupts from disrupting the interrupt service routine. The interrupt vector for the highest priority source that was pending at the beginning of the interrupt sequence is fetched, and execution continues at the referenced location. At the end of the interrupt service routine, an RTI instruction restores the content of all registers from information on the stack, and normal program execution resumes. If another interrupt is pending at the end of an interrupt service routine, the register unstacking and restacking is bypassed and the vector of the pending interrupt is fetched.

---

---

## Contents

Introduction . . . . .	97
Clock Selection and Generation . . . . .	97
Slow Mode Divider . . . . .	100
CGM Register Description . . . . .	100
Clock Functions. . . . .	101
Computer Operating Properly (COP) . . . . .	101
Real-Time Interrupt . . . . .	102
Clock Monitor . . . . .	102
Clock Function Registers . . . . .	103
Clock Divider Chains. . . . .	107

---

---

## Introduction

The clock generation module (CGM) generates the system clocks and generates and controls the timing of the reset and power-on reset logic. The clock generation module is composed of:

- clock selection and generation circuitry
- slow mode clock divider
- reset and stop generation timing and control

---

---

## Clock Selection and Generation

The clock generation module generates the P clock, the E clock, and four T clocks. The P clock and E clock are used by all device modules except the CPU. The T clocks are used by the CPU.

Clocks

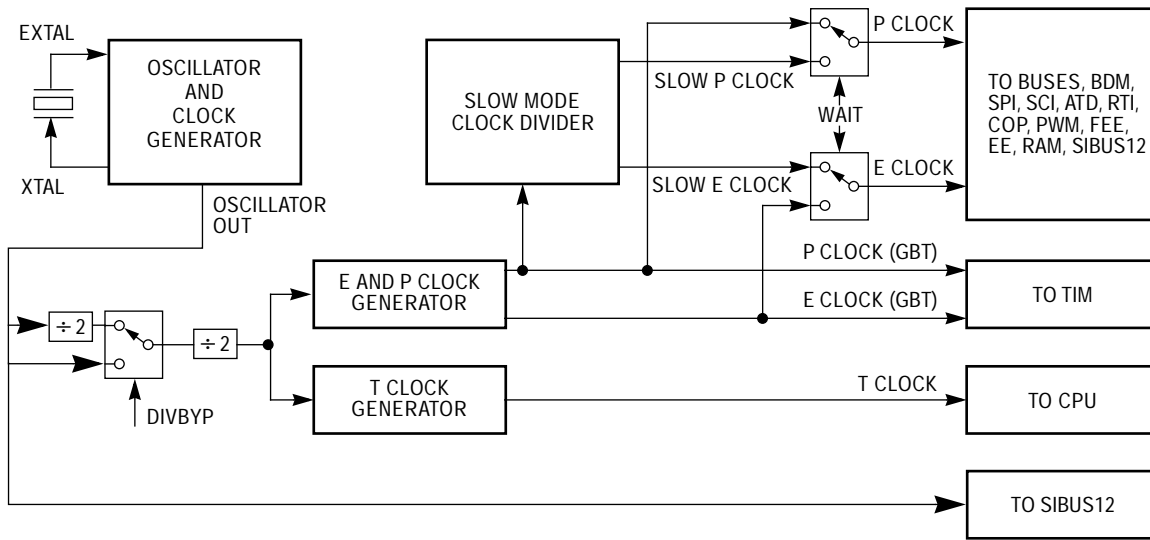

Figure 9 Clock Selection

Figure 10 shows clock timing relationships while in normal run modes.

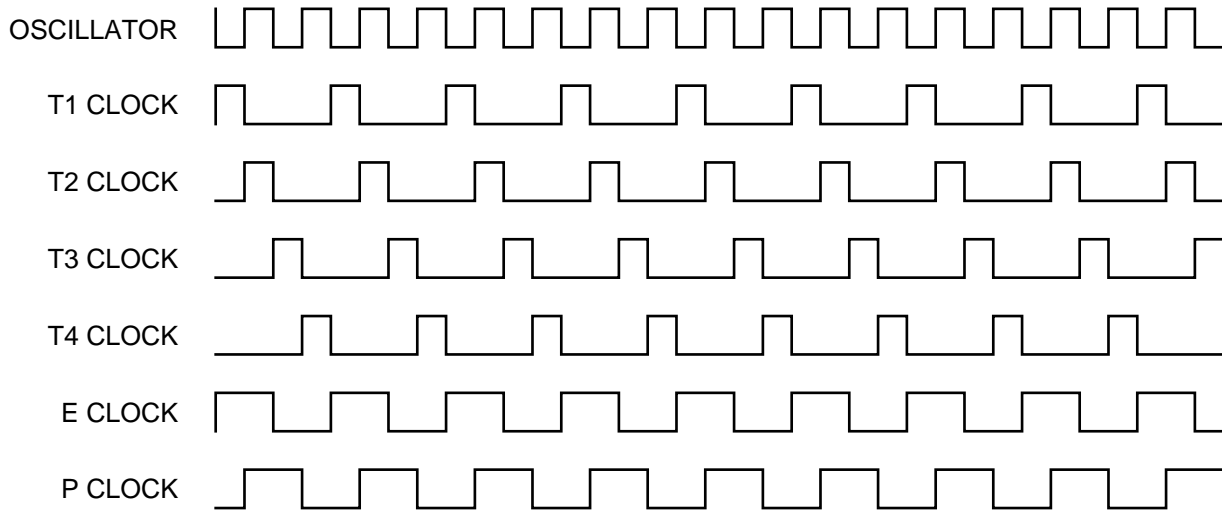
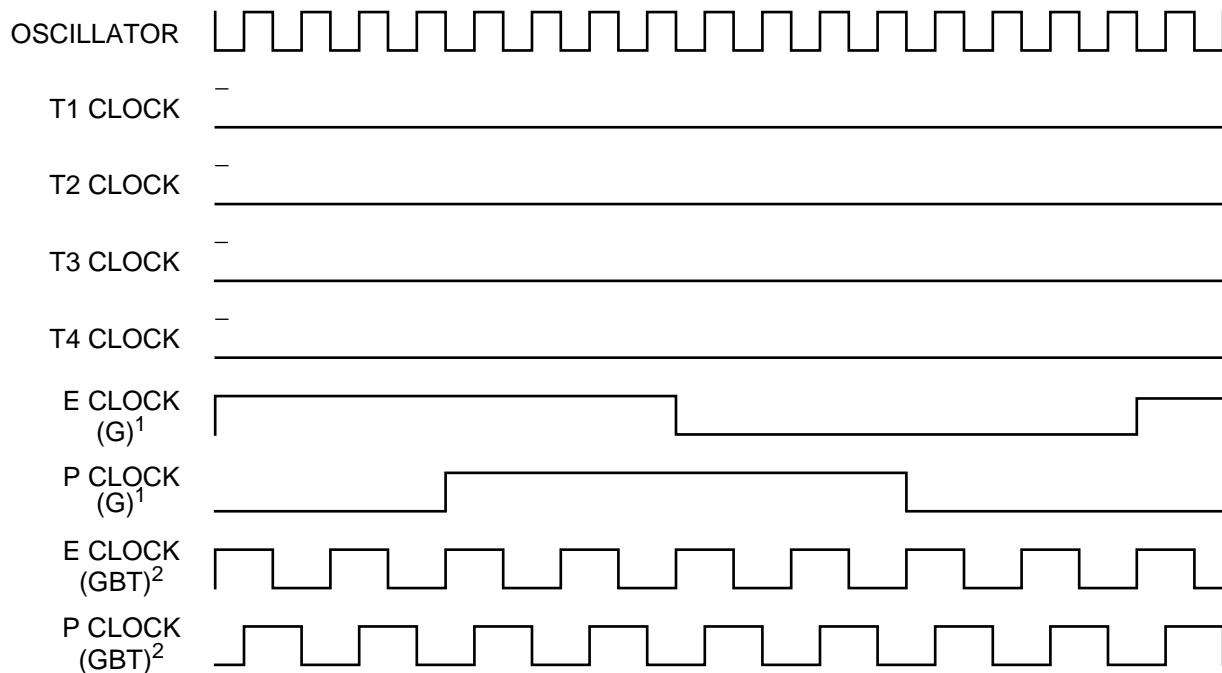

Figure 10 Internal Clock Relationships in Normal Run Modes

There are two types of P clocks and E clocks while in wait mode that are of interest to users:

- Global type (G) which is driven by the slow clock divider in wait mode and drives all on-chip peripherals except the timer
- Global type (GBT) which remains at the oscillator divide-by-2 rate in wait mode and drives and the timer.

Figure 12 shows clock timing relationships while in wait mode.



Notes:

1. Driven by slow clock divider in wait mode. Drives on-chip peripherals except timer.
2. Remains at oscillator divided by 2 rate in wait mode. Drives timer.

**Figure 11 Internal Clock Relationships in Wait Mode**

---



---

## Slow Mode Divider

The slow mode divider is included to deliver a variable bus frequency to the MCU in wait mode. The bus clocks are derived from the constant P clock. The slow clock counter divides the P clock and E clock frequency in powers of 2, up to 128. When the slow control register is cleared or the part is not in wait mode, the slow mode divider is off and the bus clocks frequency is not changed.

**NOTE:** *The clock monitor is clocked by the system clock (oscillator) reference; the slow mode divider allows operation of the MCU at clock periods longer than the clock monitor trigger time.*

---



---

## CGM Register Description

**SLOW** — Slow Mode Divider Register

**\$00E0**

	Bit 7	6	5	4	3	2	1	Bit 0
	0	0	0	0	0	SLDV2	SLDV1	SLDV0
RESET:	0	0	0	0	0	0	0	0

### SLDV2–SLDV0 — Slow Mode Divisor Selector Bits

The value 2 raised to the power indicated by these three bits, produce the slow mode frequency divider. The range of the divider is 2 to 128 by steps of power of 2. When the bits are clear, the divider is bypassed. [Figure 19](#) shows the divider for all bit conditions and the resulting bus rate for three example oscillator frequencies.



**Table 19 Slow Mode Register Divider Rates**

SLDV2	SLDV1	SLDV0	Divder (2 <sup>x</sup> )	Bus Rate (16 MHz Oscillator)	Bus Rate (32 MHz Oscillator)	Bus Rate (40 MHz Oscillator)
0	0	0	Off	4 MHz	8 MHz	20 MHz
0	0	1	2	2 MHz	4 MHz	10 MHz
0	1	0	4	1 MHz	2 MHz	5 MHz
0	1	1	8	500 kHz	1 MHz	2.5 MHz
1	0	0	16	250 kHz	500 kHz	1.25 MHz
1	0	1	32	125 kHz	250 kHz	625 kHz
1	1	0	64	62.5 kHz	125 kHz	312 kHz
1	1	1	128	31.2 kHz	62.5 kHz	156 kHz

---



---

## Clock Functions

The clock generation module generates and controls the timing of the reset and power-on reset logic.

---



---

## Computer Operating Properly (COP)

The COP or watchdog timer is an added check that a program is running and sequencing properly. When the COP is being used, software is responsible for keeping a free-running watchdog timer from timing out. If the watchdog timer times out it is an indication that the software is no longer being executed in the intended sequence; thus a system reset is initiated. Three control bits allow selection of seven COP time-out periods or COP disable. When COP is enabled, sometime during the selected period the program must write \$55 and \$AA (in this order) to the COPRST register. If the program fails to do this the part will reset. If any value other than \$55 or \$AA is written to COPRST, the part is reset.

---



---

## Real-Time Interrupt

There is a real-time (periodic) interrupt available to the user. This interrupt will occur at one of seven selected rates. An interrupt flag and an interrupt enable bit are associated with this function. There are three bits for the rate select.

---



---

## Clock Monitor

The clock monitor circuit is based on an internal resistor-capacitor (RC) time delay. If no MCU clock edges are detected within this RC time delay, the clock monitor can optionally generate a system reset. The clock monitor function is enabled/disabled by the CME control bit in the COPCTL register. This time-out is based on an RC delay so that the clock monitor can operate without any MCU clocks.

Clock monitor time-outs are shown in [Table 20](#).

**Table 20 Clock Monitor Time-Outs**

Supply	Range
5V +/- 5%	2-20 $\mu$ S

---



---

## Clock Function Registers

All register addresses shown reflect the reset state. Registers may be mapped to any 2-Kbyte space.

### RTICTL — Real-Time Interrupt Control Register

**\$0014**

	Bit 7	6	5	4	3	2	1	Bit 0
	RTIE	RSWAI	RSBCK	0	RTBYP	RTR2	RTR1	RTR0
RESET:	0	0	0	0	0	0	0	0

#### RTIE — Real-Time Interrupt Enable

Read and write anytime.

0 = Interrupt requests from RTI are disabled.

1 = Interrupt will be requested whenever RTIF is set.

#### RSWAI — RTI and COP Stop While in Wait

Write once in normal modes, anytime in special modes. Read anytime.

0 = Allows the RTI and COP to continue running in wait.

1 = Disables both the RTI and COP whenever the part goes into wait.

#### RSBCK — RTI and COP Stop While in Background Debug Mode

Write once in normal modes, anytime in special modes. Read anytime.

0 = Allows the RTI and COP to continue running while in background mode.

1 = Disables both the RTI and COP whenever the part is in background mode. This is useful for emulation.

#### RTBYP — Real-Time Interrupt Divider Chain Bypass

Write not allowed in normal modes, anytime in special modes. Read anytime.

0 = Divider chain functions normally.

1 = Divider chain is bypassed, allows faster testing (the divider chain is normally  $P$  divided by  $2^{13}$ , when bypassed becomes  $P$  divided by 4).

RTR2, RTR1, RTR0 — Real-Time Interrupt Rate Select

Read and write anytime.

Rate select for real-time interrupt. The clock used for this module is the E clock.

**Table 21 Real Time Interrupt Rates**

RTR2	RTR1	RTR0	Divide E By:	Time-Out Period E = 4.0 MHz	Time-Out Period E = 8.0 MHz	Time-Out Period E = 10.0 MHz
0	0	0	OFF	OFF	OFF	OFF
0	0	1	2 <sup>13</sup>	2.048 ms	1.024 ms	0.819 ms
0	1	0	2 <sup>14</sup>	4.096 ms	2.048 ms	1.638 ms
0	1	1	2 <sup>15</sup>	8.192 ms	4.096 ms	3.277 ms
1	0	0	2 <sup>16</sup>	16.384 ms	8.192 ms	6.554 ms
1	0	1	2 <sup>17</sup>	32.768 ms	16.384 ms	13.107 ms
1	1	0	2 <sup>18</sup>	65.536 ms	32.768 ms	26.214 ms
1	1	1	2 <sup>19</sup>	131.072 ms	65.536 ms	52.429 ms

**RTIFLG** — Real-Time Interrupt Flag Register

**\$0015**

	Bit 7	6	5	4	3	2	1	Bit 0
RTIF	0	0	0	0	0	0	0	0
RESET:	0	0	0	0	0	0	0	0

**RTIF** — Real-Time Interrupt Flag

This bit is cleared automatically by a write to this register with this bit set.

0 = Time-out has not yet occurred.

1 = Set when the time-out period is met.

**COPCTL** — COP Control Register

**\$0016**

	Bit 7	6	5	4	3	2	1	Bit 0	
	CME	FCME	FCM	FCOP	DISR	CR2	CR1	CR0	
RESET:	0	0	0	0	0	0	0	1	Normal
RESET:	0	0	0	0	1	0	0	1	Special

**CME** — Clock Monitor Enable

Read and write anytime.

If FCME is set, this bit has no meaning nor effect.

0 = Clock monitor is disabled. Slow clocks and stop instruction may be used.

1 = Slow or stopped clocks (including the stop instruction) will cause a clock reset sequence.

## FCME — Force Clock Monitor Enable

Write once in normal modes, anytime in special modes. Read anytime.

In normal modes, when this bit is set, the clock monitor function cannot be disabled until a reset occurs.

0 = Clock monitor follows the state of the CME bit.

1 = Slow or stopped clocks will cause a clock reset sequence.

In order to use both STOP and clock monitor, the CME bit should be cleared prior to executing a STOP instruction and set after recovery from STOP. If you plan on using STOP always keep FCME = 0.

## FCM — Force Clock Monitor Reset

Writes are not allowed in normal modes, anytime in special modes. Read anytime.

If DISR is set, this bit has no effect.

0 = Normal operation.

1 = Force a clock monitor reset (if clock monitor is enabled).

## FCOP — Force COP Watchdog Reset

Writes are not allowed in normal modes; can be written anytime in special modes. Read anytime.

If DISR is set, this bit has no effect.

0 = Normal operation.

1 = Force a COP reset (if COP is enabled).

## DISR — Disable Resets from COP Watchdog and Clock Monitor

Writes are not allowed in normal modes, anytime in special modes. Read anytime.

0 = Normal operation.

1 = Regardless of other control bit states, COP and clock monitor will not generate a system reset.

CR2, CR1, CR0 — COP Watchdog Timer Rate Select Bits

The COP system is driven by a constant frequency of  $E/2^{13}$ . (RTBYP in the RTICTL register allows all but two stages of this divider to be bypassed for testing in special modes only.) These bits specify an additional division factor to arrive at the COP time-out rate (the clock used for this module is the E clock).

Write once in normal modes, anytime in special modes. Read anytime.

Table 22 COP Watchdog Rates (RTBYP = 0)

CR2	CR1	CR0	Divide E By:	At E = 4.0 MHz Time-Out -0 to +2.048 s	At E = 8.0 MHz Time-Out -0 to +1.024 s	At E = 10.0 MHz Time-Out -0 to +838.861 ms
0	0	0	OFF	OFF	OFF	OFF
0	0	1	$2^{13}$	2.048 ms	1.024 ms	0.819 ms
0	1	0	$2^{15}$	8.192 ms	4.096 ms	3.277 ms
0	1	1	$2^{17}$	32.768 ms	16.384 ms	13.107 ms
1	0	0	$2^{19}$	131.072 ms	65.536 ms	52.429 ms
1	0	1	$2^{21}$	524.288 ms	262.144 ms	209.715 ms
1	1	0	$2^{22}$	1.048 s	524.288 ms	419.430 ms
1	1	1	$2^{23}$	2.097 s	1.048576 s	838.861 ms

COPRST — Arm/Reset COP Timer Register

\$0017

Bit 7	6	5	4	3	2	1	Bit 0
Bit 7	6	5	4	3	2	1	Bit 0
RESET:	0	0	0	0	0	0	0

Always reads \$00.

Writing \$55 to this address is the first step of the COP watchdog sequence.

Writing \$AA to this address is the second step of the COP watchdog sequence. Other instructions may be executed between these writes but both must be completed in the correct order prior to time-out to avoid a watchdog reset. Writing anything other than \$55 or \$AA causes a COP reset to occur.

Clock Divider Chains

Figure 12, Figure 13, and Figure 14 summarize the clock divider chains for the various peripherals on the MC68HC912BD32.

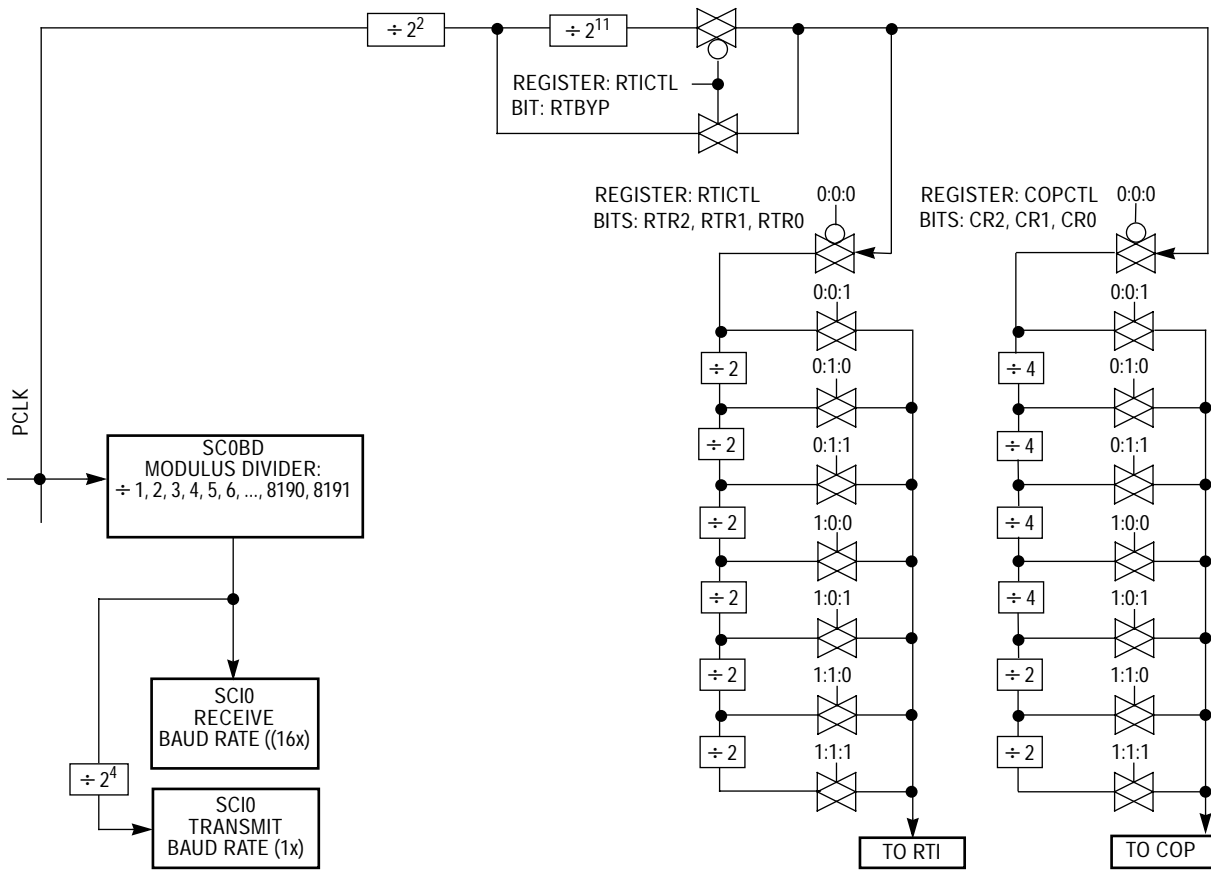

Figure 12 Clock Chain for SCI, RTI, COP

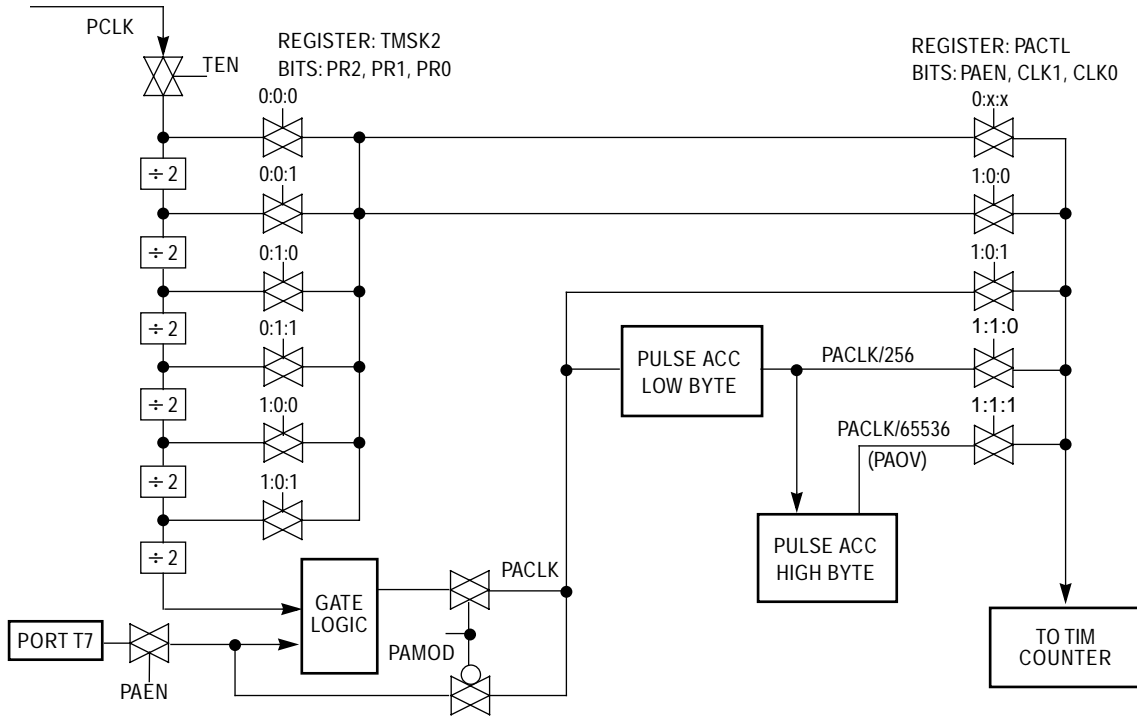

Figure 13 Clock Chain for TIM

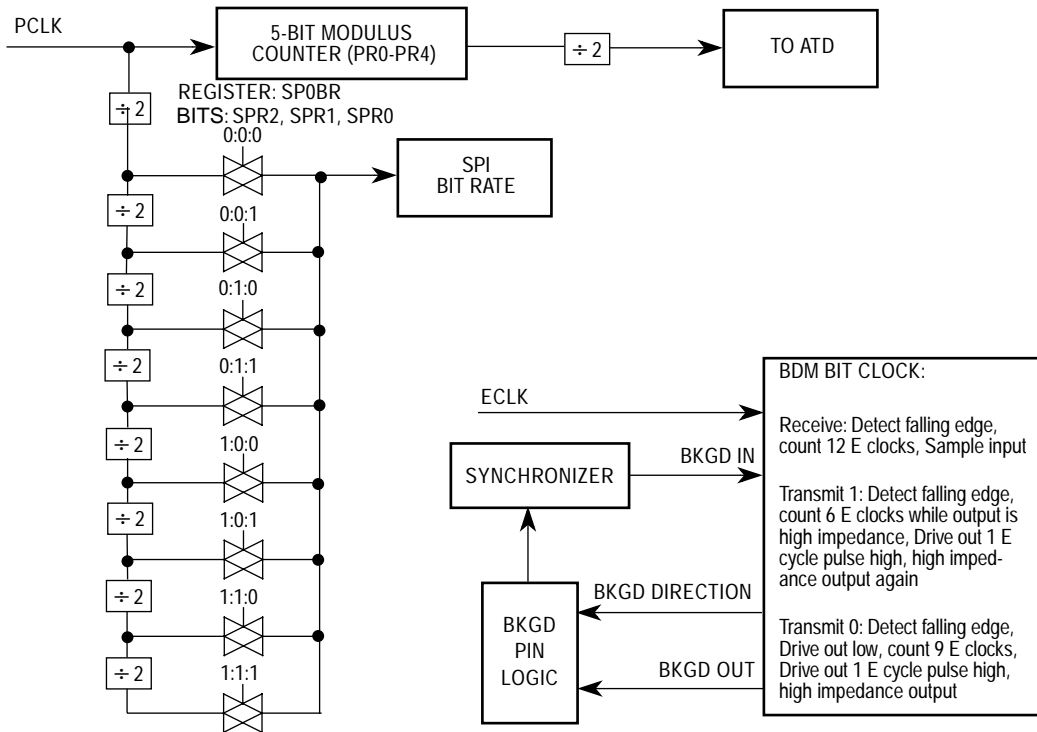

Figure 14 Clock Chain for SPI, ATD and BDM



# Pulse Width Modulator

---

---

## Contents

Introduction . . . . .	109
PWM Register Description . . . . .	114
PWM Boundary Cases . . . . .	125

---

---

## Introduction

The pulse-width modulator (PWM) subsystem provides four independent 8-bit PWM waveforms or two 16-bit PWM waveforms or a combination of one 16-bit and two 8-bit PWM waveforms. Each waveform channel has a programmable period and a programmable duty-cycle as well as a dedicated counter. A flexible clock select scheme allows four different clock sources to be used with the counters. Each of the modulators can create independent, continuous waveforms with software-selectable duty rates from 0 percent to 100 percent. The PWM outputs can be programmed as left-aligned outputs or center-aligned outputs.

The four PWM channel outputs share general-purpose port P pins. Enabling PWM pins takes precedence over the general-purpose port. When PWM are not in use, the port pins may be used for discrete input/output.

The period and duty registers are double buffered so that if they change while the channel is enabled, the change will not take effect until the counter reaches zero or the channel is disabled and then re-enabled. If the channel is not enabled then writes to the period and/or duty register will go only to the shadow latches. When the channel is enabled (PWENx) is written from 0 to 1) the counter direction is set to UP and the Shadow to Register transfer for PWPERx and PWDTYx is done.

For Center Aligned mode two additional initialization operations occur: the PWM counter is reset to \$00 and a decision for the PWM output value takes place. In this way the output of the PWM will always be; the old waveform, or the new waveform and not some variation of the two.

The pulse modulated signal becomes available at port P output when the PWM channel clock source begins its next cycle.

A change in duty or period can be forced into immediate effect by writing the new value to the duty and/or period registers and then writing to the counter. This causes the counter to reset and the new duty and/or period values to be latched (this may cause a truncated PWM period). In addition, since the counter is readable it is possible to know where the count is with respect to the duty value and software can be used to make adjustments by turning the enable bit off and on (only in Left Aligned output mode).

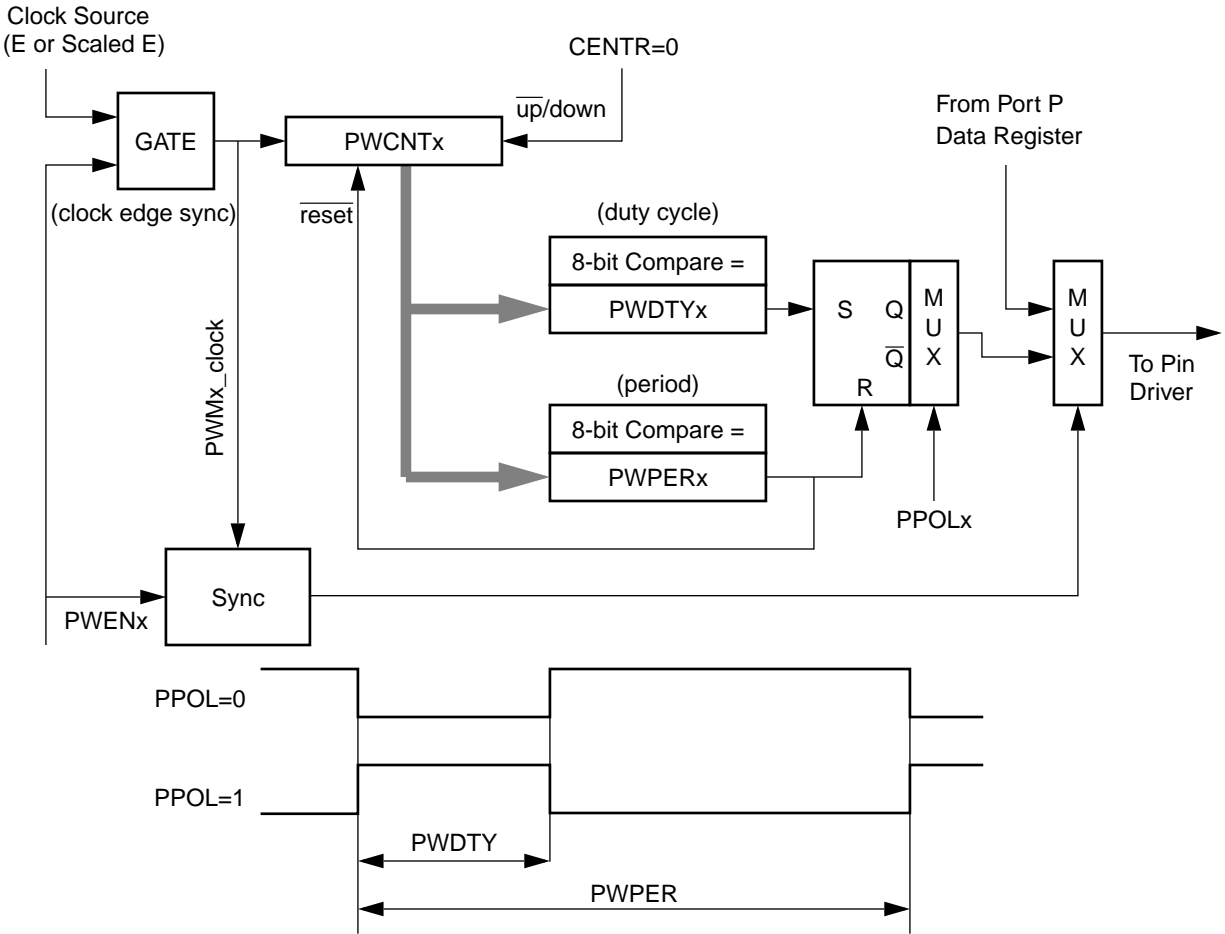

Figure 15 Block Diagram of PWM Left-Aligned Output Channel

Pulse Width Modulator

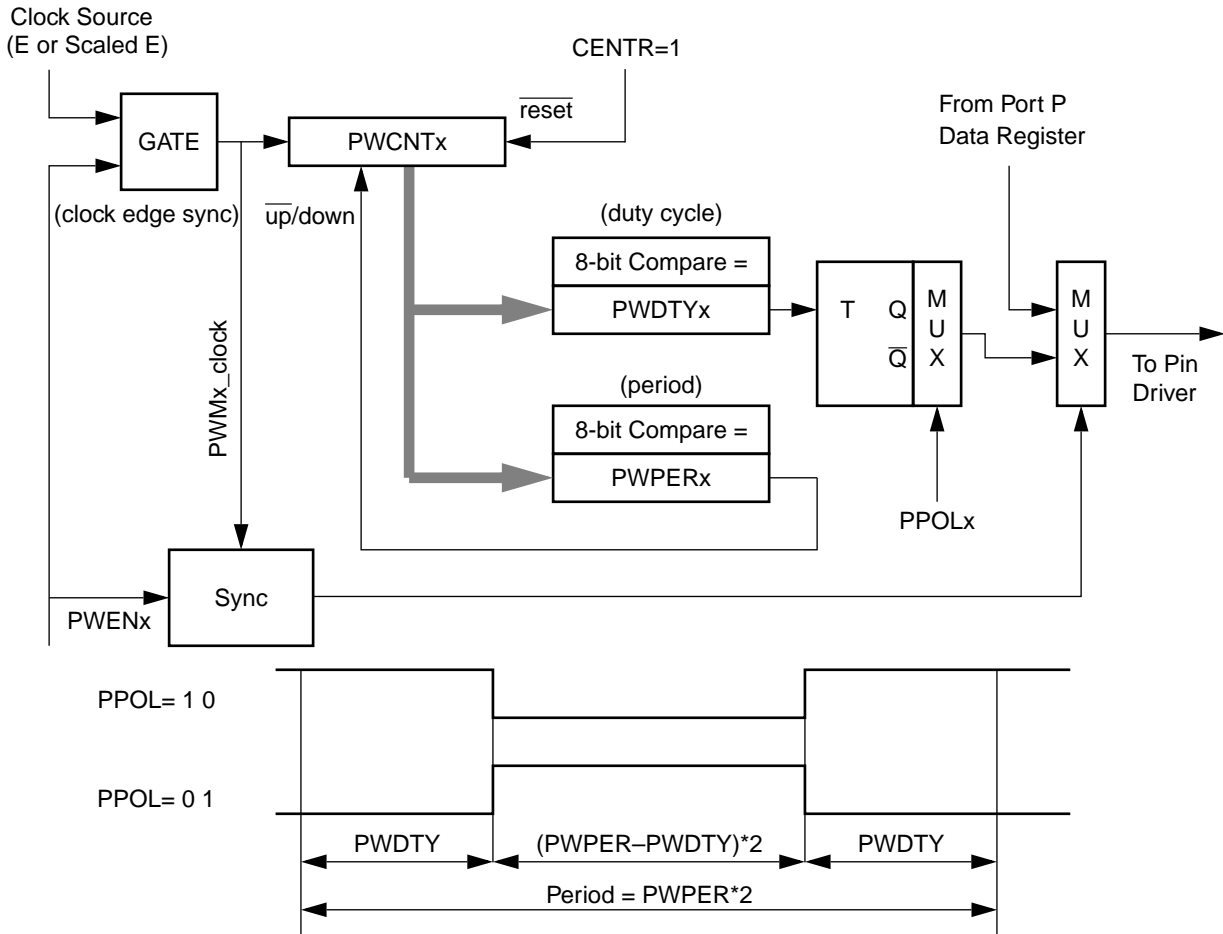

Figure 16 Block Diagram of PWM Center-Aligned Output Channel

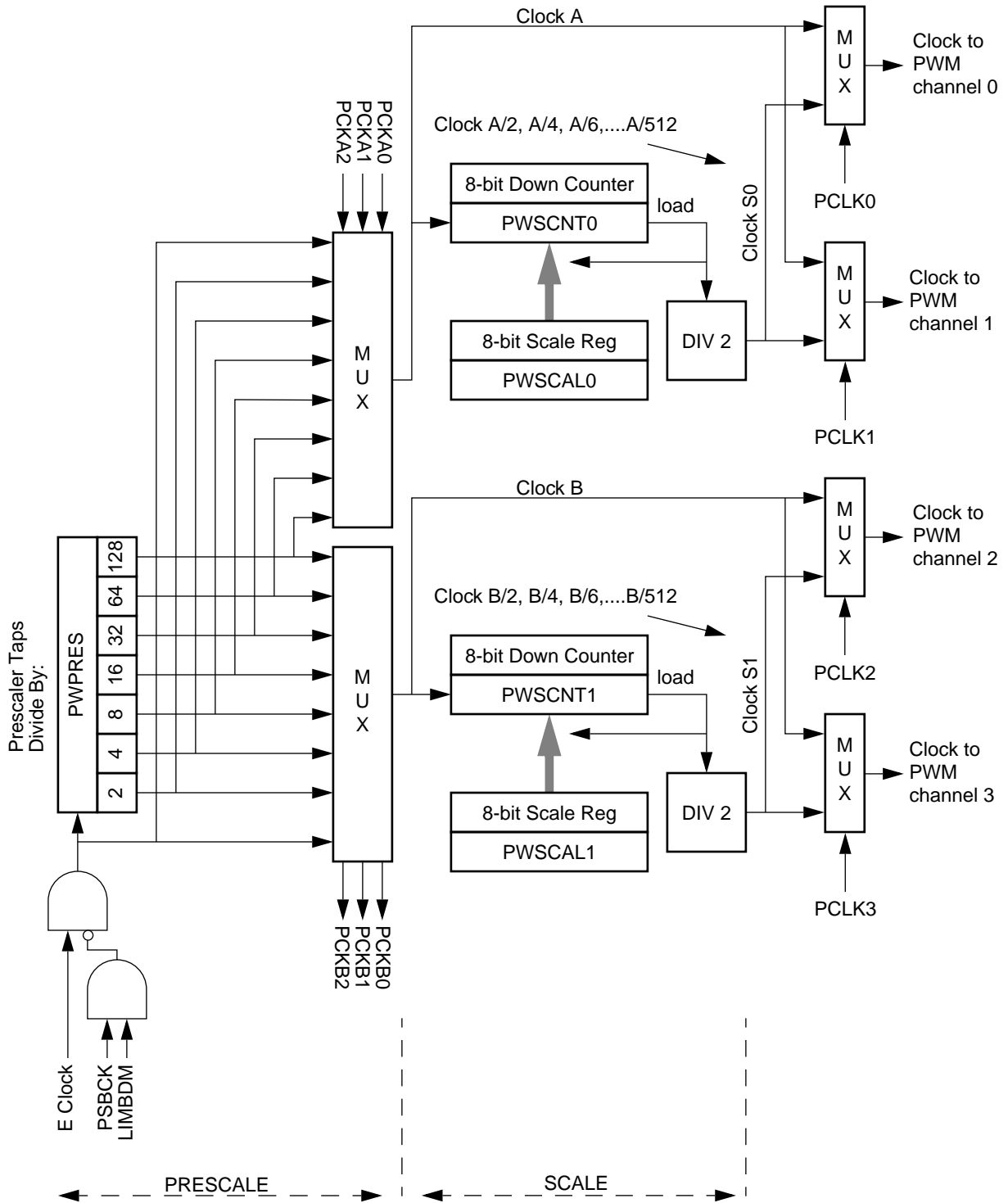

Figure 17 PWM Clock Sources

PWM Register Description

PWCLK — PWM Clock Select Register with Concatenate Bits \$0040

	Bit 7	6	5	4	3	2	1	Bit 0
	CON23	CON01	PCKA2	PCKA1	PCKA0	PCKB2	PCKB1	PCKB0
RESET:	0	0	0	0	0	0	0	0

Read and write anytime.

CON23 — Concatenate PWM Channels 2 and 3

When concatenated, channel 2 becomes the high-order byte and channel 3 becomes the low-order byte. Channel 2 output pin is used as the output for this 16-bit PWM (bit 2 of port P). Channel 3 clock-select control bits determines the clock source.

0 = Channels 2 and 3 are separate 8-bit PWMs.

1 = Channels 2 and 3 are concatenated to create one 16-bit PWM channel.

CON01 — Concatenate PWM Channels 0 and 1

When concatenated, channel 0 becomes the high-order byte and channel 1 becomes the low-order byte. Channel 0 output pin is used as the output for this 16-bit PWM (bit 0 of port P). Channel 1 clock-select control bits determines the clock source.

0 = Channels 0 and 1 are separate 8-bit PWMs.

1 = Channels 0 and 1 are concatenated to create one 16-bit PWM channel.

**NOTE:** *These bits should be changed only when both corresponding channels are disabled. For Left Aligned output mode operation when changing these bits the user should write to the associated PWM counters as the LAST operation before enabling (setting PWENx = q) the channel(s).*

PCKA2–PCKA0 — Prescaler for Clock A

Clock A is one of two clock sources which may be used for channels 0 and 1. These three bits determine the rate of clock A, as shown in [Table 23](#).

**PCKB2–PCKB0 — Prescaler for Clock B**

Clock B is one of two clock sources which may be used for channels 2 and 3. These three bits determine the rate of clock B, as shown in [Table 23](#).

**Table 23 Clock A and Clock B Prescaler**

PCKA2 (PCKB2)	PCKA1 (PCKB1)	PCKA0 (PCKB0)	Value of Clock A (B)
0	0	0	E
0	0	1	E/ 2
0	1	0	E/4
0	1	1	E/ 8
1	0	0	E/16
1	0	1	E/ 32
1	1	0	E/ 64
1	1	1	E/ 128

**PWPOL— PWM Clock Select and Polarity**

**\$0041**

	Bit 7	6	5	4	3	2	1	Bit 0
	PCLK3	PCLK2	PCLK1	PCLK0	PPOL3	PPOL2	PPOL1	PPOL0
RESET:	0	0	0	0	0	0	0	0

Read and write anytime.

**PCLK3 — PWM Channel 3 Clock Select**

- 0 = Clock B is the clock source for channel 3.
- 1 = Clock S1 is the clock source for channel 3.

**PCLK2 — PWM Channel 2 Clock Select**

- 0 = Clock B is the clock source for channel 2.
- 1 = Clock S1 is the clock source for channel 2.

**PCLK1 — PWM Channel 1 Clock Select**

- 0 = Clock A is the clock source for channel 1.
- 1 = Clock S0 is the clock source for channel 1.

**PCLK0 — PWM Channel 0 Clock Select**

- 0 = Clock A is the clock source for channel 0.
- 1 = Clock S0 is the clock source for channel 0.

### PPOL3 — PWM Channel 3 Polarity

0 = Channel 3 output is low at the beginning of the period; high when the duty count is reached.

1 = Channel 3 output is high at the beginning of the period; low when the duty count is reached.

### PPOL2 — PWM Channel 2 Polarity

0 = Channel 2 output is low at the beginning of the period; high when the duty count is reached.

1 = Channel 2 output is high at the beginning of the period; low when the duty count is reached.

### PPOL1 — PWM Channel 1 Polarity

0 = Channel 1 output is low at the beginning of the period; high when the duty count is reached.

1 = Channel 1 output is high at the beginning of the period; low when the duty count is reached.

### PPOL0 — PWM Channel 0 Polarity

0 = Channel 0 output is low at the beginning of the period; high when the duty count is reached.

1 = Channel 0 output is high at the beginning of the period; low when the duty count is reached.

**NOTE:** Register bits *PCLK0* to *PCLK3* may be written anytime. If a clock select is changed while a PWM signal is being generated, a truncated or stretched pulse may occur during transition.

**NOTE:** Depending on the polarity bit, the duty registers may contain the count of either the high time or the low time. If the polarity bit is one, the output starts high and then goes low when the duty count is reached, so the duty registers contain a count of the high time. If the polarity bit is zero, the output starts low and then goes high when the duty count is reached, so the duty registers contain a count of the low time.



**PWEN — PWM Enable**

**\$0042**

	Bit 7	6	5	4	3	2	1	Bit 0
	0	0	0	0	PWEN3	PWEN2	PWEN1	PWEN0
RESET:	0	0	0	0	0	0	0	0

Read and Write any time.

Setting any of the PWENx bits causes the associated port P line to become an output regardless of the state of the associated data direction register (DDRP) bit. This does not change the state of the data direction bit. When PWENx returns to zero, the data direction bit controls I/O direction. On the front end of the PWM channel, the scaler clock is enabled to the PWM circuit by the PWENx enable bit being high. When all four PWM channels are disabled, the prescaler counter shuts off to save power. There is an edge-synchronizing gate circuit to guarantee that the clock will only be enabled or disabled at an edge.

Read and write anytime.

**PWEN3 — PWM Channel 3 Enable**

The pulse modulated signal will be available at port P, bit 3 when its clock source begins its next cycle.

- 0 = Channel 3 is disabled.
- 1 = Channel 3 is enabled.

**PWEN2 — PWM Channel 2 Enable**

The pulse modulated signal will be available at port P, bit 2 when its clock source begins its next cycle.

- 0 = Channel 2 is disabled.
- 1 = Channel 2 is enabled.

**PWEN1 — PWM Channel 1 Enable**

The pulse modulated signal will be available at port P, bit 1 when its clock source begins its next cycle.

- 0 = Channel 1 is disabled.
- 1 = Channel 1 is enabled.

Pulse Width Modulator

PWEN0 — PWM Channel 0 Enable

The pulse modulated signal will be available at port P, bit 0 when its clock source begins its next cycle.

- 0 = Channel 0 is disabled.
- 1 = Channel 0 is enabled.

PWPRES— PWM Prescale Counter

\$0043

	Bit 7	6	5	4	3	2	1	Bit 0
	0	Bit 6	5	4	3	2	1	Bit 0
RESET:	0	0	0	0	0	0	0	0

PWPRES is a free running 7-bit counter. Read anytime. Write only in Special mode (SMOD = 1).

PWSCAL0— PWM Scale Register 0

\$0044

	Bit 7	6	5	4	3	2	1	Bit 0
	Bit 7	6	5	4	3	2	1	Bit 0
RESET:	0	0	0	0	0	0	0	0

Read and write anytime. A write will cause the scaler counter PWSCNT0 to load the PWSCAL0 value unless in Special mode with DISCAL = 1 in the PWTST register.

PWM channels 0 and 1 can select clock S0 (scaled) as its input clock by setting the control bit PCLK0 and PCLK1 respectively. Clock S0 is generated by dividing clock A by the value in the PWSCAL0 register and dividing again by two. When PWSCAL0 = \$FF, clock A is divided by 256 then divided by two to generate clock S0. In Special Mode when DISCAL = 1, writes to PWSCAL0 does not load Scale-Counter 0 (PWSCNT0).

**PWSCNT0— PWM Scale Counter 0 Value**

**\$0045**

	Bit 7	6	5	4	3	2	1	Bit 0
	Bit 7	6	5	4	3	2	1	Bit 0
RESET:	0	0	0	0	0	0	0	0

PWSCNT0 is a down-counter that, upon reaching \$00, loads the value of PWSCAL0. Read any time.

**PWSCAL1— PWM Scale Register 1**

**\$0046**

	Bit 7	6	5	4	3	2	1	Bit 0
	Bit 7	6	5	4	3	2	1	Bit 0
RESET:	0	0	0	0	0	0	0	0

Read and write anytime. A write will cause the scaler counter PWSCNT1 to load the PWSCAL1 value unless in Special mode with DISCAL =1 in the PWTST register.

PWM channels 2 and 3 can select clock S1 (scaled) as its input clock by setting the control bit PCLK2 and PCLK3 respectively. Clock S1 is generated by dividing clock B by the value in the PWSCAL1 register and dividing again by two. When PWSCAL1 = \$FF, clock B is divided by 256 then divided by two to generate clock S1.

**PWSCNT1— PWM Scale Counter 1 Value**

**\$0047**

	Bit 7	6	5	4	3	2	1	Bit 0
	Bit 7	6	5	4	3	2	1	Bit 0
RESET:	0	0	0	0	0	0	0	0

PWSCNT1 is a down-counter that, upon reaching \$00, loads the value of PWSCAL1. Read any time.

Pulse Width Modulator

**PWCNTx** — PWM Channel Counters

	Bit 7	6	5	4	3	2	1	Bit 0	
PWCNT0	Bit 7	6	5	4	3	2	1	Bit 0	\$0048
PWCNT1	Bit 7	6	5	4	3	2	1	Bit 0	\$0049
PWCNT2	Bit 7	6	5	4	3	2	1	Bit 0	\$004A
PWCNT3	Bit 7	6	5	4	3	2	1	Bit 0	\$004B
RESET	0	0	0	0	0	0	0	0	

Read and write anytime. A write will cause the PWM counter to reset to \$00.

In Special mode, if DISCR = 1, a write does not reset the PWM counter.

Each channel has its own counter. Each counter may be read any time without affecting the count or the operation of the corresponding PWM channel. Writes to a counter cause the counter to be reset to \$00 and force an immediate load of both duty and period registers with new values. In concatenated mode, writes to the 16-bit counter by using 16 bit access, or writes to the high order byte of the counter, will cause reset of the 16-bit counters. Writes to the lower byte of the counter have no effect. Reads of the 16-bit counter should be made only by 16 bit access to maintain data coherency.

**PWPERx** — PWM Channel Period Registers

	Bit 7	6	5	4	3	2	1	Bit 0	
PWPER0	Bit 7	6	5	4	3	2	1	Bit 0	\$004C
PWPER1	Bit 7	6	5	4	3	2	1	Bit 0	\$004D
PWPER2	Bit 7	6	5	4	3	2	1	Bit 0	\$004E
PWPER3	Bit 7	6	5	4	3	2	1	Bit 0	\$004F
RESET	1	1	1	1	1	1	1	1	

Read and write anytime.

There is a dedicated period register for each channel. The value in the period register determines the period of the associated PWM channel. If written while the channel is enabled, the new value will not take effect until the existing period terminates, forcing the counter to reset. The new period is then latched and is used until a new period

value is written. Reading this register returns the most recent value written. When in concatenated mode, the new period should be written with a 16-bit access to both channels registers (0 & 1, or 2 & 3) for data coherency. To start a new period immediately, write the new period value and then write the counter forcing a new period to start with the new period value.

$$\text{Period} = [\text{Channel-Clock-Period} \times (\text{PWPER} + 1)](\text{CENTR} = 0)$$

$$\text{Period} = [\text{Channel-Clock-Period} \times (\text{PWPER} \times 2)](\text{CENTR} = 1)$$

**NOTE:** For Boundary Case programming values please refer to [PWM Boundary Cases](#).

## PWDTYx — PWM Channel Duty Registers

	Bit 7	6	5	4	3	2	1	Bit 0	
PWDTY0	Bit 7	6	5	4	3	2	1	Bit 0	\$0050
PWDTY1	Bit 7	6	5	4	3	2	1	Bit 0	\$0051
PWDTY2	Bit 7	6	5	4	3	2	1	Bit 0	\$0052
PWDTY3	Bit 7	6	5	4	3	2	1	Bit 0	\$0053
RESET	1	1	1	1	1	1	1	1	

Read and write anytime.

The value in each duty register determines the duty of the associated PWM channel. The duty value is compared to the counter and if it is equal to the counter value a match occurs and the output changes state. If the register is written to while the channel is enabled, then the new value is held in the buffer until the counter reaches zero or the channel is disabled and re-enabled. When in concatenated mode the new period should be written to both channels registers (0 & 1, or 2 & 3) with a 16 bit access for data coherency. Reading this register returns the most recent value written.

**NOTE:** For Boundary Case programming values please refer to [PWM Boundary Cases](#).

Left-Aligned-Output Mode (CENTR = 0):

$$\text{Duty cycle} = [(PWDTYx + 1) / (PWPERx + 1)] \times 100\% \text{ (PPOLx = 1)}$$

$$\text{Duty cycle} = [(PWPERx - PWDTYx) / (PWPERx + 1)] \times 100\% \text{ (PPOLx = 0)}$$

Center-Aligned-Output Mode (CENTR = 1):

$$\text{Duty cycle} = [(PWPERx - PWDTYx) / PWPERx] \times 100\% \text{ (PPOLx = 1)}$$

$$\text{Duty cycle} = (PWDTYx) / (PWPERx) \times 100\% \text{ (PPOLx = 0)}$$

**PWCTL— PWM Control Register**

**\$0054**

	Bit 7	6	5	4	3	2	1	Bit 0
	0	0	0	PSWAI	CENTR	RDP	PUPP	PSBCK
RESET:	0	0	0	0	0	0	0	0

Read and write anytime.

**PSWAI — PWM Halts while in Wait Mode**

0 = Allows PWM main clock generator to continue while in Wait mode.

1 = Halt PWM main clock generator when the part is in Wait mode.

**CENTR — Center-Aligned Output Mode**

Program change of CENTR bit should be done when PWM channels are disabled. All PWM counters should be written to as the last operation before enabling the channels. Otherwise, asserting/de-asserting the CENTR bit may cause irregularities in the PWM output.

0 = PWM channels operate in Left-Aligned Output mode

1 = PWM channels operate in Center-Aligned Output mode

**RDP — Reduced Drive of Port P**

0 = All port P output pins have normal drive capability.

1 = All port P output pins have reduced drive capability.

**PUPP — Pull-Up Port P Enable**

0 = All port P pins have an active pull-up device disabled.

1 = All port P pins have an active pull-up device enabled.

## PSBCK — PWM Stops while in Background Mode

0 = Allows PWM to continue while in background mode. This is useful for emulation.

1 = Disable PWM input clock when the part is in background mode.

## PWTST— PWM Special Mode Register (“Test”)

**\$0055**

	Bit 7	6	5	4	3	2	1	Bit 0
	DISCR	DISCP	DISCAL	0	0	0	0	0
RESET:	0	0	0	0	0	0	0	0

Read anytime but write only in Special mode (SMOD = 1). These bits are available only in Special mode and are reset in Normal mode.

The PWM has some special test functions which are only accessible when the device is in Special Mode. Special Mode is indicated to the PWM module when the SMOD line on the LIB is asserted.

When the SMOD line is asserted, the Special Mode register control bits are accessed via the LIB. When SMOD is not asserted, writes to the Special Mode control bits have no effect and all bits in the Special Mode register are forced to 0. This ensures that the PWM Special Mode can not be invoked inadvertently during normal operation.

### DISCR — Disable Reset of Channel Counter on Write to Channel Counter

0 = Normal operation. Write to PWM channel counter will reset channel counter.

1 = Write to PWM channel counter does not reset channel counter.

### DISCP — Disable Compare Count Period

0 = Normal Operation

1 = In Left-Aligned Output mode, match of period does not reset the associated PWM counter register.

### DISCAL — Disable load of Scale-counters on write to the associated scale-registers

0 = Normal Operation

1 = Write to PWSCAL0 and PWSCAL1 does not load scale counters

Pulse Width Modulator

PORTPP — Port P Data Register

\$0056

	Bit 7	6	5	4	3	2	1	Bit 0
	PP7	PP6	PP5	PP4	PP3	PP2	PP1	PP0
PWM	–	–	–	–	PWM3	PWM2	PWM1	PWM0
RESET:	–	–	–	–	–	–	–	–

PWM functions share port P pins 3 to 0 and take precedence over the general-purpose port when enabled.

READ: any time (input configured pin return pin level; output configured pin return internal latch pin driver input level.

WRITE: Data stored in an internal latch (drives pins only if configured for output and corresponding PWM channel not enabled).

**NOTE:** Writes do not change pin state when pin is configured for PWM outputs, only after the PWM channel becomes available on port P pin, see PWEN bit description.

PORTPD — Port P Data Direction Register

\$0057

	Bit 7	6	5	4	3	2	1	Bit 0
	DDP7	DDP6	DDP5	DDP4	DDP3	DDP2	DDP1	DDP0
RESET:	0	0	0	0	0	0	0	0

This register determines whether each pin is input or output when it is selected to be a general purpose I/O pin. Reading Port P Data Register always follows pin data associated with the Port P Data Direction bit. Read and write any time.

DDRP[7:0] — Data Direction Port P pins  
 0 = Configure I/O pin for input only  
 1 = Configure I/O for output



---



---

## PWM Boundary Cases

The boundary conditions for the PWM channel duty registers and the PWM channel period registers cause these results:

**Table 24 PWM Boundary Conditions**

PWDTYx	PWPERx	PPOLx	Output
\$FF	>\$00	1	Low
\$FF	>\$00	0	High
≥PWPERx	–	1	High
≥PWPERx	–	0	Low
–	\$00	1	High
–	\$00	0	Low



# Standard Timer Module

---

---

## Contents

Introduction . . . . .	127
Timer Registers . . . . .	129
Timer Operation in Modes . . . . .	142

---

---

## Introduction

The standard timer module consists of a 16-bit software-programmable counter driven by a prescaler. It contains eight complete 16-bit input capture/output compare channels and one 16-bit pulse accumulator.

This timer can be used for many purposes, including input waveform measurements while simultaneously generating an output waveform. Pulse widths can vary from less than a microsecond to many seconds. It can also generate PWM signals without CPU intervention.

Standard Timer Module

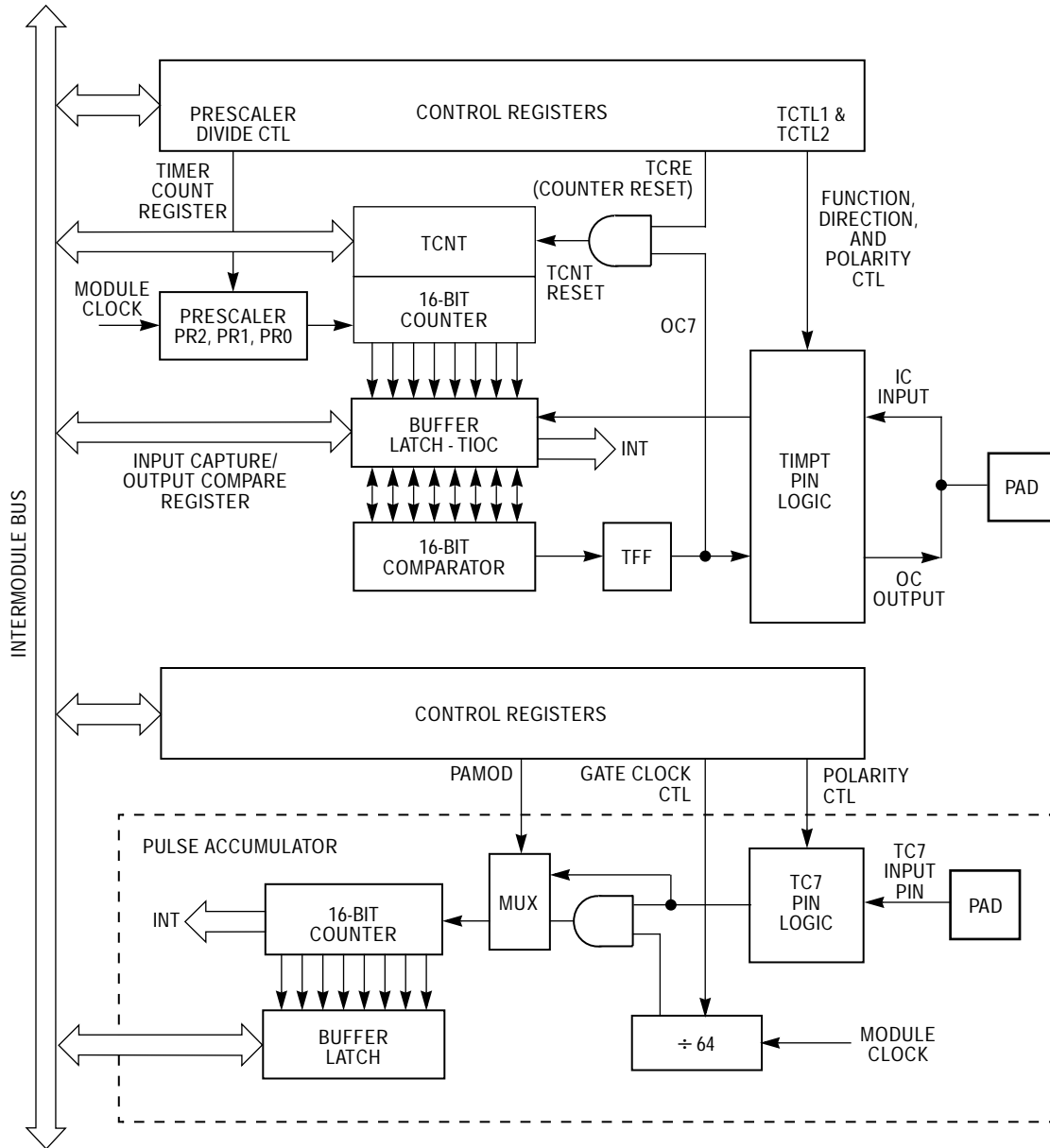

Figure 18 Timer Block Diagram: Input Capture, Output Compare, Pulse Accumulator

---



---

## Timer Registers

Input/output pins default to general-purpose I/O lines until an internal function which uses that pin is specifically enabled. The timer overrides the state of the DDR to force the I/O state of each associated port line when an output compare using a port line is enabled. In these cases the data direction bits will have no affect on these lines.

When a pin is assigned to output an on-chip peripheral function, writing to this PORTTn bit does not affect the pin but the data is stored in an internal latch such that if the pin becomes available for general-purpose output the driven level will be the last value written to the PORTTn bit.

### **TIOS** — Timer Input Capture/Output Compare Select

**\$0080**

	Bit 7	6	5	4	3	2	1	Bit 0
	IOS7	IOS6	IOS5	IOS4	IOS3	IOS2	IOS1	IOS0
RESET:	0	0	0	0	0	0	0	0

Read or write anytime.

#### IOS[7:0] — Input Capture or Output Compare Channel Configuration

0 = The corresponding channel acts as an input capture

1 = The corresponding channel acts as an output compare.

### **CFORC** — Timer Compare Force Register

**\$0081**

	Bit 7	6	5	4	3	2	1	Bit 0
	FOC7	FOC6	FOC5	FOC4	FOC3	FOC2	FOC1	FOC0
RESET:	0	0	0	0	0	0	0	0

Read anytime but will always return \$00 (1 state is transient). Write anytime.

#### FOC[7:0] — Force Output Compare Action for Channel 7-0

A write to this register with the corresponding data bit(s) set causes the action which is programmed for output compare “n” to occur immediately. The action taken is the same as if a successful comparison had just taken place with the TCn register except the interrupt flag does not get set.

Standard Timer Module

**OC7M** — Output Compare 7 Mask Register

**\$0082**

	Bit 7	6	5	4	3	2	1	Bit 0
	OC7M7	OC7M6	OC7M5	OC7M4	OC7M3	OC7M2	OC7M1	OC7M0
RESET:	0	0	0	0	0	0	0	0

Read or write anytime.

The bits of OC7M correspond bit-for-bit with the bits of timer port (PORTT). Setting the OC7Mn will set the corresponding port to be an output port regardless of the state of the DDRTn bit when the corresponding TIOSn bit is set to be an output compare. This does not change the state of the DDRT bits.

**OC7D** — Output Compare 7 Data Register

**\$0083**

	Bit 7	6	5	4	3	2	1	Bit 0
	OC7D7	OC7D6	OC7D5	OC7D4	OC7D3	OC7D2	OC7D1	OC7D0
RESET:	0	0	0	0	0	0	0	0

Read or write anytime.

The bits of OC7D correspond bit-for-bit with the bits of timer port (PORTT). When a successful OC7 compare occurs, for each bit that is set in OC7M, the corresponding data bit in OC7D is stored to the corresponding bit of the timer port.

When the OC7Mn bit is set, a successful OC7 action will override a successful OC[6:0] compare action during the same cycle; therefore, the OCn action taken will depend on the corresponding OC7D bit.

**TCNT** — Timer Count Register

**\$0084–\$0085**

	Bit 7	6	5	4	3	2	1	Bit 0
	Bit 15	14	13	12	11	10	9	Bit 8
	Bit 7	6	5	4	3	2	1	Bit 0
RESET:	0	0	0	0	0	0	0	0

A full access for the counter register should take place in one clock cycle. A separate read/write for high byte and low byte will give a different result than accessing them as a word.

Read anytime.

Write has no meaning or effect in the normal mode; only writable in special modes (SMODN = 0).

The period of the first count after a write to the TCNT registers may be a different size because the write is not synchronized with the prescaler clock.

**TSCR — Timer System Control Register**

**\$0086**

	Bit 7	6	5	4	3	2	1	Bit 0
	TEN	TSWAI	TSBCK	TFFCA	0	0	0	0
RESET:	0	0	0	0	0	0	0	0

Read or write anytime.

**TEN — Timer Enable**

0 = Disables the timer, including the counter. Can be used for reducing power consumption.

1 = Allows the timer to function normally.

If for any reason the timer is not active, there is no  $\div 64$  clock for the pulse accumulator since the  $E\div 64$  is generated by the timer prescaler.

**TSWAI — Timer Stops While in Wait**

0 = Allows the timer to continue running during wait.

1 = Disables the timer when the MCU is in the wait mode. Timer interrupts cannot be used to get the MCU out of wait.

**TSBCK — Timer Stops While in Background Mode**

0 = Allows the timer to continue running while in background mode.

1 = Disables the timer whenever the MCU is in background mode. This is useful for emulation.

**TFFCA — Timer Fast Flag Clear All**

0 = Allows the timer flag clearing to function normally.

1 = For TFLG1(\$8E), a read from an input capture or a write to the output compare channel (\$90–\$9F) causes the corresponding channel flag, CnF, to be cleared. For TFLG2 (\$8F), any access to the TCNT register (\$84, \$85) clears the TOF flag. Any access to the PACNT register (\$A2, \$A3) clears the PAOVF and PAIF flags in the PAFLG register (\$A1). This has the

Standard Timer Module

advantage of eliminating software overhead in a separate clear sequence. Extra care is required to avoid accidental flag clearing due to unintended accesses.

**TQCR — Reserved**

**\$0087**

	Bit 7	6	5	4	3	2	1	Bit 0
	0	0	0	0	0	0	0	0
RESET:	0	0	0	0	0	0	0	0

**TCTL1 — Timer Control Register 1**

**\$0088**

	Bit 7	6	5	4	3	2	1	Bit 0
	OM7	OL7	OM6	OL6	OM5	OL5	OM4	OL4
RESET:	0	0	0	0	0	0	0	0

**TCTL2 — Timer Control Register 2**

**\$0089**

	Bit 7	6	5	4	3	2	1	Bit 0
	OM3	OL3	OM2	OL2	OM1	OL1	OM0	OL0
RESET:	0	0	0	0	0	0	0	0

Read or write anytime.

OMn — Output Mode

OLn — Output Level

These eight pairs of control bits are encoded to specify the output action to be taken as a result of a successful OCn compare. When either OMn or OLn is one, the pin associated with OCn becomes an output tied to OCn regardless of the state of the associated DDRT bit.

**Table 25 Compare Result Output Action**

OMn	OLn	Action
0	0	Timer disconnected from output pin logic
0	1	Toggle OCn output line
1	0	Clear OCn output line to zero
1	1	Set OCn output line to one



**TCTL3 — Timer Control Register 3**

**\$008A**

	Bit 7	6	5	4	3	2	1	Bit 0
	EDG7B	EDG7A	EDG6B	EDG6A	EDG5B	EDG5A	EDG4B	EDG4A
RESET:	0	0	0	0	0	0	0	0

**TCTL4 — Timer Control Register 4**

**\$008B**

	Bit 7	6	5	4	3	2	1	Bit 0
	EDG3B	EDG3A	EDG2B	EDG2A	EDG1B	EDG1A	EDG0B	EDG0A
RESET:	0	0	0	0	0	0	0	0

Read or write anytime.

EDGnB, EDGnA — Input Capture edge control

These eight pairs of control bits configure the input capture edge detector circuits.

**Table 26 Edge Detector Circuit Configuration**

EDGnB	EDGnA	Configuration
0	0	Capture disabled
0	1	Capture on rising edges only
1	0	Capture on falling edges only
1	1	Capture on any edge (rising or falling)

**TMSK1 — Timer Interrupt Mask 1**

**\$008C**

	Bit 7	6	5	4	3	2	1	Bit 0
	C7I	C6I	C5I	C4I	C3I	C2I	C1I	C0I
RESET:	0	0	0	0	0	0	0	0

The bits in TMSK1 correspond bit-for-bit with the bits in the TFLG1 status register. If cleared, the corresponding flag is disabled from causing a hardware interrupt. If set, the corresponding flag is enabled to cause a hardware interrupt.

Read or write anytime.

C7I–C0I—Input Capture/Output Compare “x” Interrupt enable.

Standard Timer Module

**TMSK2** — Timer Interrupt Mask 2

**\$008D**

	Bit 7	6	5	4	3	2	1	Bit 0
	TOI	0	PUPT	RDPT	TCRE	PR2	PR1	PR0
RESET:	0	0	0	0	0	0	0	0

Read or write anytime.

**TOI** — Timer Overflow Interrupt Enable

0 = Interrupt inhibited

1 = Hardware interrupt requested when TOF flag set

**PUPT** — Timer Pull-Up Resistor Enable

This enable bit controls pull-up resistors on the timer port pins when the pins are configured as inputs.

1 = Enable pull-up resistor function

0 = Disable pull-up resistor function

**RDPT** — Timer Drive Reduction

This bit reduces the effective output driver size which can reduce power supply current and generated noise depending upon pin loading.

1 = Enable output drive reduction function

0 = Normal output drive capability

**TCRE** — Timer Counter Reset Enable

This bit allows the timer counter to be reset by a successful output compare 7 event.

0 = Counter reset inhibited and counter free runs

1 = Counter reset by a successful output compare 7

If TC7 = \$0000 and TCRE = 1, TCNT will stay at \$0000 continuously.

If TC7 = \$FFFF and TCRE = 1, TOF will never get set even though TCNT will count from \$0000 through \$FFFF.

**PR2, PR1, PR0** — Timer Prescaler Select

These three bits specify the number of ÷2 stages that are to be inserted between the module clock and the timer counter.

**Table 27 Prescaler Selection**

PR2	PR1	PR0	Prescale Factor
0	0	0	1
0	0	1	2
0	1	0	4
0	1	1	8
1	0	0	16
1	0	1	32
1	1	0	Reserved
1	1	1	Reserved

The newly selected prescale factor will not take effect until the next synchronized edge where all prescale counter stages equal zero.

**TFLG1** — Timer Interrupt Flag 1

**\$008E**

	Bit 7	6	5	4	3	2	1	Bit 0
	C7F	C6F	C5F	C4F	C3F	C2F	C1F	C0F
RESET:	0	0	0	0	0	0	0	0

TFLG1 indicates when interrupt conditions have occurred. To clear a bit in the flag register, write a one to the bit.

Read anytime. Write used in the clearing mechanism (set bits cause corresponding bits to be cleared). Writing a zero will not effect current status of the bit.

When TFFCA bit in TSCR register is set, a read from an input capture or a write into an output compare channel (\$90–\$9F) will cause the corresponding channel flag CnF to be cleared.

C7F–C0F — Input Capture/Output Compare Channel “n” Flag.

**TFLG2** — Timer Interrupt Flag 2

**\$008F**

	Bit 7	6	5	4	3	2	1	Bit 0
TOF	0	0	0	0	0	0	0	0
RESET:	0	0	0	0	0	0	0	0

TFLG2 indicates when interrupt conditions have occurred. To clear a bit in the flag register, set the bit to one.

Read anytime. Write used in clearing mechanism (bits set cause corresponding bits to be cleared).

Any access to TCNT will clear TFLG2 register if the TFFCA bit in TSCR register is set.

**TOF** — Timer Overflow Flag

Set when 16-bit free-running timer overflows from \$FFFF to \$0000. This bit is cleared automatically by a write to the TFLG2 register with bit 7 set. (See also TCRE control bit explanation.)

**TC0 — Timer Input Capture/Output Compare Register 0 \$0090–\$0091**

Bit 7	6	5	4	3	2	1	Bit 0
Bit 15	14	13	12	11	10	9	Bit 8
Bit 7	6	5	4	3	2	1	Bit 0

**TC1 — Timer Input Capture/Output Compare Register 1 \$0092–\$0093**

Bit 7	6	5	4	3	2	1	Bit 0
Bit 15	14	13	12	11	10	9	Bit 8
Bit 7	6	5	4	3	2	1	Bit 0

**TC2 — Timer Input Capture/Output Compare Register 2 \$0094–\$0095**

Bit 7	6	5	4	3	2	1	Bit 0
Bit 15	14	13	12	11	10	9	Bit 8
Bit 7	6	5	4	3	2	1	Bit 0

**TC3 — Timer Input Capture/Output Compare Register 3 \$0096–\$0097**

Bit 7	6	5	4	3	2	1	Bit 0
Bit 15	14	13	12	11	10	9	Bit 8
Bit 7	6	5	4	3	2	1	Bit 0

**TC4 — Timer Input Capture/Output Compare Register 4 \$0098–\$0099**

Bit 7	6	5	4	3	2	1	Bit 0
Bit 15	14	13	12	11	10	9	Bit 8
Bit 7	6	5	4	3	2	1	Bit 0

**TC5 — Timer Input Capture/Output Compare Register 5 \$009A–\$009B**

Bit 7	6	5	4	3	2	1	Bit 0
Bit 15	14	13	12	11	10	9	Bit 8
Bit 7	6	5	4	3	2	1	Bit 0

**TC6 — Timer Input Capture/Output Compare Register 6 \$009C–\$009D**

Bit 7	6	5	4	3	2	1	Bit 0
Bit 15	14	13	12	11	10	9	Bit 8
Bit 7	6	5	4	3	2	1	Bit 0

**TC7 — Timer Input Capture/Output Compare Register 7 \$009E–\$009F**

Bit 7	6	5	4	3	2	1	Bit 0
Bit 15	14	13	12	11	10	9	Bit 8
Bit 7	6	5	4	3	2	1	Bit 0

Depending on the TIOS bit for the corresponding channel, these registers are used to latch the value of the free-running counter when a defined transition is sensed by the corresponding input capture edge detector or to trigger an output action for output compare.

Read anytime. Write anytime for output compare function. Writes to these registers have no meaning or effect during input capture. All timer input capture/output compare registers are reset to \$0000.

**PACTL — Pulse Accumulator Control Register**

**\$00A0**

	Bit 7	6	5	4	3	2	1	Bit 0
	0	PAEN	PAMOD	PEDGE	CLK1	CLK0	PAOVI	PAI
RESET:	0	0	0	0	0	0	0	0

Read or write anytime.

**PAEN — Pulse Accumulator System Enable**

0 = Pulse Accumulator system disabled

1 = Pulse Accumulator system enabled

PAEN is independent from TEN.

**PAMOD — Pulse Accumulator Mode**

0 = Event counter mode

1 = Gated time accumulation mode

**PEDGE — Pulse Accumulator Edge Control**

For PAMOD = 0 (event counter mode)

0 = Falling edges on the pulse accumulator input pin (PT7/PAI) cause the count to be incremented

1 = Rising edges on the pulse accumulator input pin cause the count to be incremented

For PAMOD = 1 (gated time accumulation mode)

0 = Pulse accumulator input pin high enables E÷64 clock to pulse accumulator and the trailing falling edge on the pulse accumulator input pin sets the PAIF flag.

1 = Pulse accumulator input pin low enables E÷64 clock to pulse accumulator and the trailing rising edge on the pulse accumulator input pin sets the PAIF flag.

If the timer is not active (TEN = 0 in TSCR), there is no ÷64 clock since the E÷64 clock is generated by the timer prescaler.

CLK1, CLK0 — Clock Select Register

**Table 28 Clock Selection**

CLK1	CLK0	Selected Clock
0	0	Use timer prescaler clock as timer counter clock
0	1	Use PCLK as input to timer counter clock
1	0	Use PCLK/256 as timer counter clock frequency
1	1	Use PCLK/65536 as timer counter clock frequency

If the pulse accumulator is disabled (PAEN = 0), the prescaler clock from the timer is always used as an input clock to the timer counter. The change from one selected clock to the other happens immediately after these bits are written.

PAOVI — Pulse Accumulator Overflow Interrupt Enable

- 0 = Interrupt inhibited
- 1 = Interrupt requested if PAOVF is set

PAI — Pulse Accumulator Input Interrupt Enable

- 0 = Interrupt inhibited
- 1 = Interrupt requested if PAIF is set

**PAFLG — Pulse Accumulator Flag Register**

**\$00A1**

	Bit 7	6	5	4	3	2	1	Bit 0
	0	0	0	0	0	0	PAOVF	PAIF
RESET:	0	0	0	0	0	0	0	0

Read or write anytime.

When TFFCA bit in the TSCR register is set, any access to the PACNT register will clear all the flags in the PAFLG register.

PAOVF — Pulse Accumulator Overflow Flag

Set when the 16-bit pulse accumulator overflows from \$FFFF to \$0000. This bit is cleared automatically by a write to the PAFLG register with bit 1 set.

**PAIF — Pulse Accumulator Input Edge Flag**

Set when the selected edge is detected at the pulse accumulator input pin. In event mode, the event edge triggers PAIF. In gated time accumulation mode, the trailing edge of the gate signal at the pulse accumulator input pin triggers PAIF. This bit is cleared automatically by a write to the PAFLG register with bit 0 set.

**PACNT — 16-bit Pulse Accumulator Count Register**

**\$00A2–\$00A3**

	Bit 7	6	5	4	3	2	1	Bit 0
	Bit 15	14	13	12	11	10	9	Bit 8
	Bit 7	6	5	4	3	2	1	Bit 0
RESET:	0	0	0	0	0	0	0	0

Full count register access should take place in one clock cycle. A separate read/write for high byte and low byte will give a different result than accessing them as a word.

Read or write anytime.

**TIMTST — Timer Test Register**

**\$00AD**

	Bit 7	6	5	4	3	2	1	Bit 0
	0	0	0	0	0	0	TCBYP	PCBYP
RESET:	0	0	0	0	0	0	0	0

Read anytime. Write only in special mode (SMODN = 0)

**TCBYP — Timer Divider Chain Bypass**

0 = Normal operation

1 = The 16-bit free-running timer counter is divided into two 8-bit halves and the prescaler is bypassed. The clock drives both halves directly.

**PCBYP — Pulse Accumulator Divider Chain Bypass**

0 = Normal operation

1 = The 16-bit pulse accumulator counter is divided into two 8-bit halves and the prescaler is bypassed. The clock drives both halves directly.



**PORTT** — Timer Port Data Register

**\$00AE**

	Bit 7	6	5	4	3	2	1	Bit 0
	PT7	PT6	PT5	PT4	PT3	PT2	PT1	PT0
TIMER	I/OC7	I/OC6	I/OC5	I/OC4	I/OC3	I/OC2	I/OC1	I/OC0
PA	PAI							

PORTT can be read anytime. When configured as an input, a read will return the pin level. When configured as output, a read will return the latched output data.

**NOTE:** *Writes do not change pin state when the pin is configured for timer output. The minimum pulse width for pulse accumulator input should always be greater than two module clocks due to input synchronizer circuitry. The minimum pulse width for the input capture should always be greater than the width of two module clocks due to input synchronizer circuitry.*

**DDRT** — Data Direction Register for Timer Port

**\$00AF**

	Bit 7	6	5	4	3	2	1	Bit 0
	DDT7	DDT6	DDT5	DDT4	DDT3	DDT2	DDT1	DDT0
RESET:	0	0	0	0	0	0	0	0

Read or write anytime.

- 0 = Configures the corresponding I/O pin for input only
- 1 = Configures the corresponding I/O pin for output

The timer forces the I/O state to be an output for each timer port pin associated with an enabled output compare. In these cases the data direction bits will not be changed but have no affect on the direction of these pins. The DDRT will revert to controlling the I/O direction of a pin when the associated timer output compare is disabled. Input captures do not override the DDRT settings.

---

---

## Timer Operation in Modes

- STOP: Timer is off since both PCLK and ECLK are stopped.
- BDM: Timer keeps running, unless TSBCK = 1
- WAIT: Counters keep running, unless TSWAI = 1
- NORMAL: Timer keeps running, unless TEN = 0
- TEN = 0: All timer operations are stopped, registers may be accessed.  
Gated pulse accumulator  $\div 64$  clock is also disabled.
- PAEN = 0: All pulse accumulator operations are stopped, registers may be accessed.

# Serial Interface

---

---

## Contents

Introduction . . . . .	143
Block diagram . . . . .	144
Serial Communication Interface (SCI) . . . . .	144
Serial Peripheral Interface (SPI) . . . . .	155
Port S . . . . .	164

---

---

## Introduction

The serial interface of the MC68HC912BD32 consists of two independent serial I/O sub-systems: the serial communication interface (SCI) and the serial peripheral interface (SPI). Each serial pin shares function with the general-purpose port pins of port S. The SCI is an NRZ type system that is compatible with standard RS-232 systems. The SCI system has a single wire operation mode which allows the unused pin to be available as general-purpose I/O. The SPI subsystem, which is compatible with the M68HC11 SPI, includes new features such as  $\overline{SS}$  output and bidirectional mode.

Block diagram

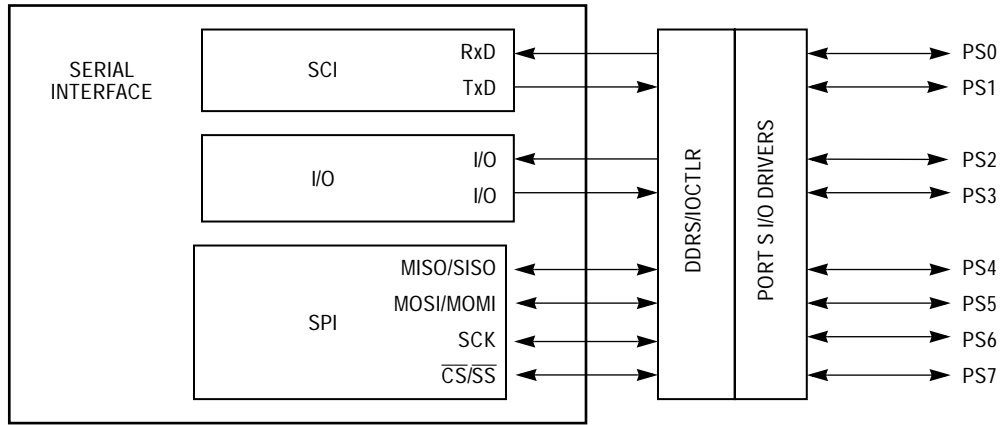

Figure 19 Serial Interface Block Diagram

Serial Communication Interface (SCI)

The serial communication interface on the MC68HC912BD32 is an NRZ format (one start, eight or nine data, and one stop bit) asynchronous communication system with independent internal baud rate generation circuitry and an SCI transmitter and receiver. It can be configured for eight or nine data bits (one of which may be designated as a parity bit, odd or even). If enabled, parity is generated in hardware for transmitted and received data. Receiver parity errors are flagged in hardware. The baud rate generator is based on a modulus counter, allowing flexibility in choosing baud rates. There is a receiver wake-up feature, an idle line detect feature, a loop-back mode, and various error detection features. Two port pins provide the external interface for the transmitted data (TXD) and the received data (RXD).

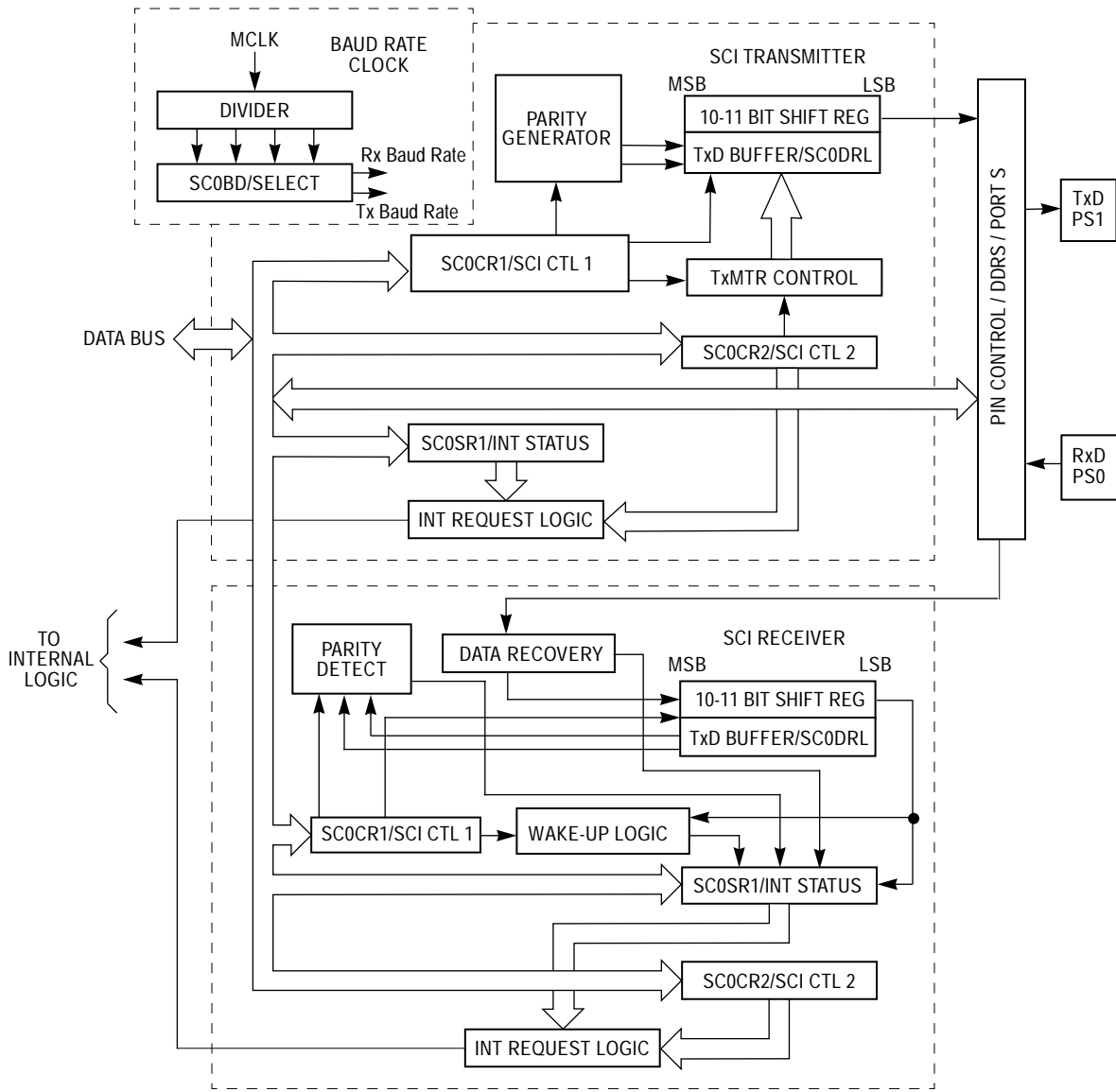

Figure 20 Serial Communications Interface Block Diagram

Data Format

The serial data format requires the following conditions:

- An idle-line in the high state before transmission or reception of a message.
- A start bit (logic zero), transmitted or received, that indicates the start of each character.

- Data that is transmitted or received least significant bit (LSB) first.
- A stop bit (logic one), used to indicate the end of a frame. (A frame consists of a start bit, a character of eight or nine data bits and a stop bit.)
- A BREAK is defined as the transmission or reception of a logic zero for one frame or more.
- This SCI supports hardware parity for transmit and receive.

**SCI Baud Rate Generation**

The basis of the SCI baud rate generator is a 13-bit modulus counter. This counter gives the generator the flexibility necessary to achieve a reasonable level of independence from the CPU operating frequency and still be able to produce standard baud rates with a minimal amount of error. The clock source for the generator comes from the P Clock.

**Table 29 Baud Rate Generation**

Desired SCI Baud Rate	BR Divisor for P = 4.0 MHz	BR Divisor for P = 8.0 MHz	BR Divisor for P = 10.0 MHz
110	2273	4545	5682
300	833	1667	2083
600	417	833	1042
1200	208	417	521
2400	104	208	260
4800	52	104	130
9600	26	52	65
14400	17	35	43
19200	13	26	33
38400	—	13	16

**Register Descriptions**

Control and data registers for the SCI subsystem are described below. The memory address indicated for each register is the default address that is in use after reset. The entire 512-byte register block can be mapped to any 2K byte boundary within the standard 64K byte address space.

## SC0BDH — SCI Baud Rate Control Register

\$00C0

	Bit 7	6	5	4	3	2	1	Bit 0	
	BTST	BSPL	BRLD	SBR12	SBR11	SBR10	SBR9	SBR8	High
RESET:	0	0	0	0	0	0	0	0	

## SC0BDL — SCI Baud Rate Control Register

\$00C1

	Bit 7	6	5	4	3	2	1	Bit 0	
	SBR7	SBR6	SBR5	SBR4	SBR3	SBR2	SBR1	SBR0	Low
RESET:	0	0	0	0	0	1	0	0	

SC0BDH and SC0BDL are considered together as a 16-bit baud rate control register.

Read any time. Write SBR[12:0] anytime. Low order byte must be written for change to take effect. Write SBR[15:13] only in special modes. The value in SBR[12:0] determines the baud rate of the SCI. The desired baud rate is determined by the following formula:

$$\text{SCI Baud Rate} = \frac{\text{MCLK}}{16 \times \text{BR}}$$

which is equivalent to:

$$\text{BR} = \frac{\text{MCLK}}{16 \times \text{SCI Baud Rate}}$$

BR is the value written to bits SBR[12:0] to establish baud rate.

**NOTE:** *The baud rate generator is disabled until the TE or RE bit in SC0CR2 register is set for the first time after reset, and/or the baud rate generator is disabled when SBR[12:0] = 0.*

BTST — Baud Register Test

Reserved for test function

BSPL — Baud Rate Counter Split

Reserved for test function

BRLD — Baud Rate Reload

Reserved for test function

SC0CR1 — SCI Control Register 1

\$00C2

	Bit 7	6	5	4	3	2	1	Bit 0
	LOOPS	WOMS	RSRC	M	WAKE	ILT	PE	PT
RESET:	0	0	0	0	0	0	0	0

Read or write anytime.

LOOPS — SCI LOOP Mode/Single Wire Mode Enable

0 = SCI transmit and receive sections operate normally.

1 = SCI receive section is disconnected from the RXD pin and the RXD pin is available as general purpose I/O. The receiver input is determined by the RSRC bit. The transmitter output is controlled by the associated DDRS bit. Both the transmitter and the receiver must be enabled to use the LOOP or the single wire mode.

If the DDRS bit associated with the TXD pin is set during the LOOPS = 1, the TXD pin outputs the SCI waveform. If the DDRS bit associated with the TXD pin is clear during the LOOPS = 1, the TXD pin becomes high (IDLE line state) for RSRC = 0 and high impedance for RSRC = 1. Refer to [Table 30](#).

WOMS — Wired-Or Mode for Serial Pins

This bit controls the two pins (TXD and RXD) associated with the SCI section.

0 = Pins operate in a normal mode with both high and low drive capability. To affect the RXD bit, that bit would have to be configured as an output (via DDRS) which is the single wire case when using the SCI. WOMS bit still affects general purpose output on TXD and RXD pins when SCI is not using these pins.

1 = Each pin operates in an open drain fashion if that pin is declared as an output.

RSRC — Receiver Source

When LOOPS = 1, the RSRC bit determines the internal feedback path for the receiver.

0 = Receiver input is connected to the transmitter internally (not TXD pin)

1 = Receiver input is connected to the TXD pin



**Table 30 Loop Mode Functions**

LOOPS	RSRC	DDS1(3)	WOMS	Function of Port S Bit 1/3
0	x	x	x	Normal Operations
1	0	0	0/1	LOOP mode without TXD output (TXD = High Impedance)
1	0	1	0	LOOP mode with TXD output (CMOS)
1	0	1	1	LOOP mode with TXD output (open-drain)
1	1	0	x	Single wire mode without TXD output (the pin is used as receiver input only, TXD = High Impedance)
1	1	1	0	Single wire mode with TXD output (the output is also fed back to receiver input, CMOS)
1	1	1	1	Single wire mode for the receiving and transmitting (open-drain)

M — Mode (select character format)  
 0 = One start, eight data, one stop bit  
 1 = One start, eight data, ninth data, one stop bit

WAKE — Wakeup by Address Mark/Idle  
 0 = Wake up by IDLE line recognition  
 1 = Wake up by address mark (last data bit set)

ILT — Idle Line Type

Determines which of two types of idle line detection will be used by the SCI receiver.

0 = Short idle line mode is enabled.  
 1 = Long idle line mode is detected.

In the short mode, the SCI circuitry begins counting ones in the search for the idle line condition immediately after the start bit. This means that the stop bit and any bits that were ones before the stop bit could be counted in that string of ones, resulting in earlier recognition of an idle line.

In the long mode, the SCI circuitry does not begin counting ones in the search for the idle line condition until a stop bit is received. Therefore, the last byte's stop bit and preceding "1" bits do not affect how quickly an idle line condition can be detected.

PE — Parity Enable  
 0 = Parity is disabled.  
 1 = Parity is enabled.

PT — Parity Type

If parity is enabled, this bit determines even or odd parity for both the receiver and the transmitter.

0 = Even parity is selected. An even number of ones in the data character causes the parity bit to be zero and an odd number of ones causes the parity bit to be one.

1 = Odd parity is selected. An odd number of ones in the data character causes the parity bit to be zero and an even number of ones causes the parity bit to be one.

SC0CR2 — SCI Control Register 2

\$00C3

	Bit 7	6	5	4	3	2	1	Bit 0
	TIE	TCIE	RIE	ILIE	TE	RE	RWU	SBK
RESET:	0	0	0	0	0	0	0	0

Read or write anytime.

TIE — Transmit Interrupt Enable

0 = TDRE interrupts disabled

1 = SCI interrupt will be requested whenever the TDRE status flag is set.

TCIE — Transmit Complete Interrupt Enable

0 = TC interrupts disabled

1 = SCI interrupt will be requested whenever the TC status flag is set.

RIE — Receiver Interrupt Enable

0 = RDRF and OR interrupts disabled

1 = SCI interrupt will be requested whenever the RDRF status flag or the OR status flag is set.

ILIE — Idle Line Interrupt Enable

0 = IDLE interrupts disabled

1 = SCI interrupt will be requested whenever the IDLE status flag is set.

**TE — Transmitter Enable**

0 = Transmitter disabled

1 = SCI transmit logic is enabled and the TXD pin (Port S bit 1) is dedicated to the transmitter. The TE bit can be used to queue an idle preamble.

**RE — Receiver Enable**

0 = Receiver disabled

1 = Enables the SCI receive circuitry

**RWU — Receiver Wake-Up Control**

0 = Normal SCI Receiver

1 = Enables the wake-up function and inhibits further receiver interrupts. Normally hardware wakes the receiver by automatically clearing this bit.

**SBK — Send Break**

0 = Break generator off

1 = Generate a break code (at least 10 or 11 contiguous zeros)

As long as SBK remains set the transmitter will send zeros. When SBK is changed to zero, the current frame of all zeros is finished before the TxD line goes to the idle state. If SBK is toggled on and off, the transmitter will send 10 (or 11) zeros and then revert to mark idle or sending data.

**SC0SR1 — SCI Status Register 1**

**\$00C4**

	Bit 7	6	5	4	3	2	1	Bit 0
	TDRE	TC	RDRF	IDLE	OR	NF	FE	PF
RESET:	1	1	0	0	0	0	0	0

The bits in these registers are set by various conditions in the SCI hardware and are automatically cleared by special acknowledge sequences. The receive related flag bits in SC0SR1 (RDRF, IDLE, OR, NF, FE, and PF) are all cleared by a read of the SC0SR1 register followed by a read of the transmit/receive data register L. However, only those bits which were set when SC0SR1 was read will be cleared by the subsequent read of the transmit/receive data register L. The

transmit related bits in SC0SR1 (TDRE and TC) are cleared by a read of the SC0SR1 register followed by a write to the transmit/receive data register L.

Read anytime (used in auto clearing mechanism). Write has no meaning or effect.

### TDRE — Transmit Data Register Empty Flag

New data will not be transmitted unless SC0SR1 is read before writing to the transmit data register. Reset sets this bit.

0 = SC0DR busy

1 = Any byte in the transmit data register is transferred to the serial shift register so new data may now be written to the transmit data register.

### TC — Transmit Complete Flag

Flag is set when the transmitter is idle (no data, preamble, or break transmission in progress). Clear by reading SC0SR1 with TC set and then writing to SC0DR.

0 = Transmitter busy

1 = Transmitter is idle

### RDRF — Receive Data Register Full Flag

Once cleared, IDLE is not set again until the RxD line has been active and becomes idle again. RDRF is set if a received character is ready to be read from SC0DR. Clear the RDRF flag by reading SC0SR1 with RDRF set and then reading SC0DR.

0 = SC0DR empty

1 = SC0DR full

### IDLE — Idle Line Detected Flag

Receiver idle line is detected (the receipt of a minimum of 10/11 consecutive ones). This bit will not be set by the idle line condition when the RWU bit is set. Once cleared, IDLE will not be set again until after RDRF has been set (after the line has been active and becomes idle again).

0 = RxD line is idle

1 = RxD line is active

## OR — Overrun Error Flag

New byte is ready to be transferred from the receive shift register to the receive data register and the receive data register is already full (RDRF bit is set). Data transfer is inhibited until this bit is cleared.

- 0 = No overrun
- 1 = Overrun detected

## NF — Noise Error Flag

Set during the same cycle as the RDRF bit but not set in the case of an overrun (OR).

- 0 = Unanimous decision
- 1 = Noise on a valid start bit, any of the data bits, or on the stop bit

## FE — Framing Error Flag

Set when a zero is detected where a stop bit was expected. Clear the FE flag by reading SC0SR1 with FE set and then reading SC0DR.

- 0 = Stop bit detected
- 1 = Zero detected rather than a stop bit

## PF — Parity Error Flag

Indicates if received data's parity matches parity bit. This feature is active only when parity is enabled. The type of parity tested for is determined by the PT (parity type) bit in SC0CR1.

- 0 = Parity correct
- 1 = Incorrect parity detected

Serial Interface

**SC0SR2** — SCI Status Register 2

**\$00C5**

	Bit 7	6	5	4	3	2	1	Bit 0
	0	0	0	0	0	0	0	RAF
RESET:	0	0	0	0	0	0	0	0

Read anytime. Write has no meaning or effect.

**RAF** — Receiver Active Flag

This bit is controlled by the receiver front end. It is set during the RT1 time period of the start bit search. It is cleared when an idle state is detected or when the receiver circuitry detects a false start bit (generally due to noise or baud rate mismatch).

0 = A character is not being received

1 = A character is being received

**SC0DRH** — SCI Data Register High

**\$00C6**

	Bit 7	6	5	4	3	2	1	Bit 0
	R8	T8	0	0	0	0	0	0
RESET:	0	0	0	0	0	0	0	0

**SC0DRL** — SCI Data Register Low

**\$00C7**

	Bit 7	6	5	4	3	2	1	Bit 0
	R7/T7	R6/T6	R5/T5	R4/T4	R3/T3	R2/T2	R1/T1	R0/T0
RESET:	0	0	0	0	0	0	0	0

**R8** — Receive Bit 8

Read anytime. Write has no meaning or affect.

This bit is the ninth serial data bit received when the SCI system is configured for nine-data-bit operation.

**T8** — Transmit Bit 8

Read or write anytime.

This bit is the ninth serial data bit transmitted when the SCI system is configured for nine-data-bit operation. When using 9-bit data format this bit does not have to be written for each data word. The same value will be transmitted as the ninth bit until this bit is rewritten.

## R7/T7–R0/T0 — Receive/Transmit Data Bits 7 to 0

Reads access the eight bits of the read-only SCI receive data register (RDR). Writes access the eight bits of the write-only SCI transmit data register (TDR). SC0DRL:SC0DRH form the 9-bit data word for the SCI. If the SCI is being used with a 7- or 8-bit data word, only SC0DRL needs to be accessed. If a 9-bit format is used, the upper register should be written first to ensure that it is transferred to the transmitter shift register with the lower register.

---

---

## Serial Peripheral Interface (SPI)

The serial peripheral interface allows the MC68HC912BD32 to communicate synchronously with peripheral devices and other microprocessors. The SPI system in the MC68HC912BD32 can operate as a master or as a slave. The SPI is also capable of interprocessor communications in a multiple master system.

When the SPI is enabled, all pins that are defined by the configuration as inputs will be inputs regardless of the state of the DDRS bits for those pins. All pins that are defined as SPI outputs will be outputs only if the DDRS bits for those pins are set. Any SPI output whose corresponding DDRS bit is cleared can be used as a general-purpose input.

A bidirectional serial pin is possible using the DDRS as the direction control.

### SPI Baud Rate Generation

The P clock is input to a divider series and the resulting SPI clock rate may be selected to be P divided by 2, 4, 8, 16, 32, 64, 128 or 256. Three bits in the SP0BR register control the SPI clock rate. This baud rate generator is activated only when SPI is in the master mode and serial transfer is taking place. Otherwise this divider is disabled to save power.

### SPI Operation

In the SPI system the 8-bit data register in the master and the 8-bit data register in the slave are linked to form a distributed 16-bit register. When a data transfer operation is performed, this 16-bit register is serially shifted eight bit positions by the SCK clock from the master so the data

is effectively exchanged between the master and the slave. Data written to the SP0DR register of the master becomes the output data for the slave and data read from the SP0DR register of the master after a transfer operation is the input data from the slave.

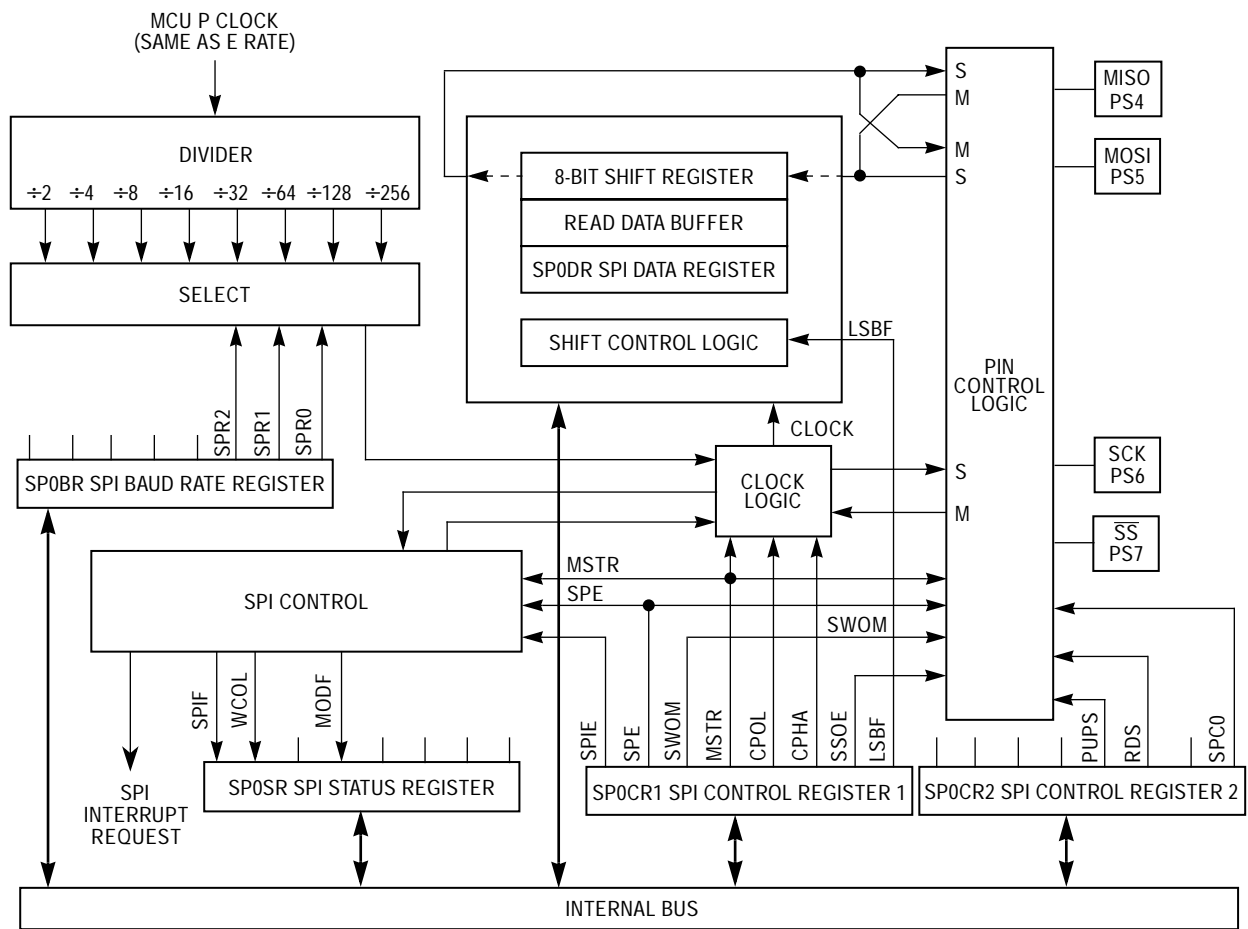

Figure 21 Serial Peripheral Interface Block Diagram

A clock phase control bit (CPHA) and a clock polarity control bit (CPOL) in the SP0CR1 register select one of four possible clock formats to be used by the SPI system. The CPOL bit simply selects non-inverted or inverted clock. The CPHA bit is used to accommodate two fundamentally different protocols by shifting the clock by one half cycle or no phase shift.



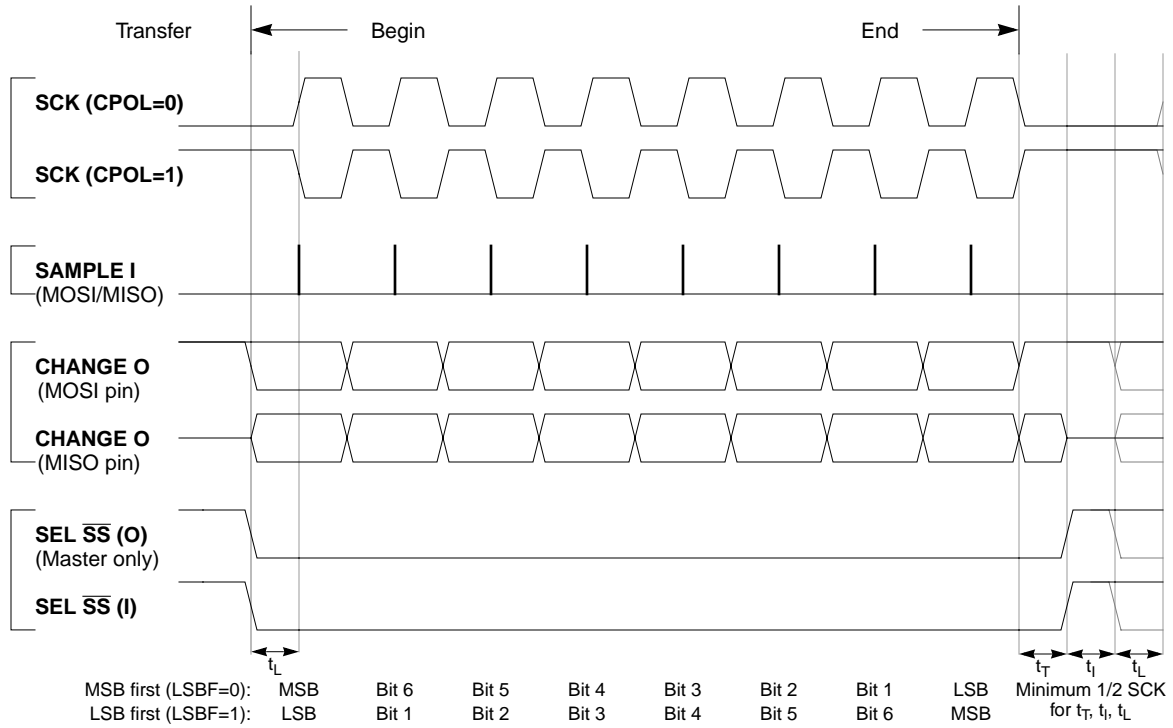

Figure 22 SPI Clock Format 0 (CPHA = 0)

Serial Interface

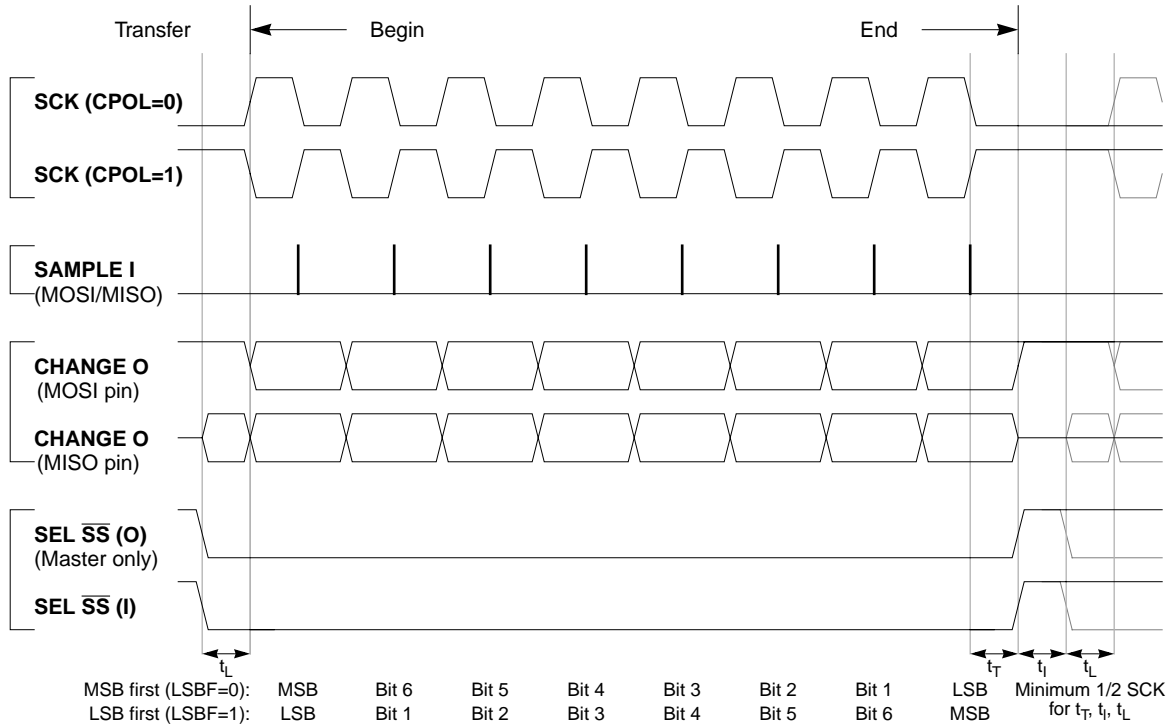

Figure 23 SPI Clock Format 1 (CPHA = 1)

$\overline{SS}$  Output

Available in master mode only,  $\overline{SS}$  output is enabled with the SSOE bit in the SP0CR1 register if the corresponding DD RS bit is set. The  $\overline{SS}$  output pin will be connected to the  $\overline{SS}$  input pin of the external slave device. The  $\overline{SS}$  output automatically goes low for each transmission to select the external device and it goes high during each idling state to deselect external devices.

Table 31  $\overline{SS}$  Output Selection

DDS7	SSOE	Master Mode	Slave Mode
0	0	$\overline{SS}$ Input with MODF Feature	$\overline{SS}$ Input
0	1	Reserved	$\overline{SS}$ Input
1	0	General-Purpose Output	$\overline{SS}$ Input
1	1	$\overline{SS}$ Output	$\overline{SS}$ Input

**Bidirectional Mode (MOMI or SISO)**

In bidirectional mode, the SPI uses only one serial data pin for external device interface. The MSTR bit decides which pin to be used. The MOSI pin becomes serial data I/O (MOMI) pin for the master mode, and the MISO pin becomes serial data I/O (SISO) pin for the slave mode. The direction of each serial I/O pin depends on the corresponding DDRS bit.

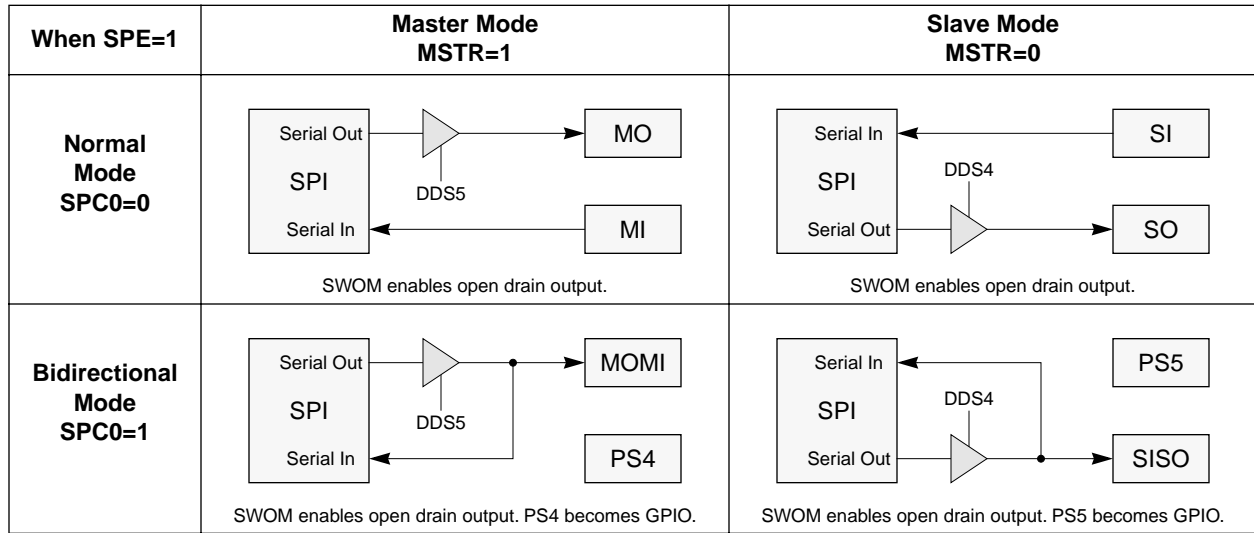

**Figure 24 Normal Mode and Bidirectional Mode**

**Register Descriptions**

Control and data registers for the SPI subsystem are described below. The memory address indicated for each register is the default address that is in use after reset. The entire 512-byte register block can be mapped to any 2K byte boundary within the standard 64K byte address space. For more information refer to [Operating Modes](#).

**SP0CR1** — SPI Control Register 1

**\$00D0**

	Bit 7	6	5	4	3	2	1	Bit 0
	SPIE	SPE	SWOM	MSTR	CPOL	CPHA	SSOE	LSBF
RESET:	0	0	0	0	0	1	0	0

Read or write anytime.

**SPIE** — SPI Interrupt Enable

- 1 = Hardware interrupt sequence is requested each time the SPIF or MODF status flag is set
- 0 = SPI interrupts are inhibited

**SPE** — SPI System Enable

- 0 = SPI internal hardware is initialized and SPI system is in a low-power disabled state.
- 1 = PS[4:7] are dedicated to the SPI function

When MODF is set, SPE always reads zero. SP0CR1 must be written as part of a mode fault recovery sequence.

**SWOM** — Port S Wired-OR Mode

- Controls not only SPI output pins but also the general-purpose output pins (PS[4:7]) which are not used by SPI.
- 0 = SPI and/or PS[4:7] output buffers operate normally
  - 1 = SPI and/or PS[4:7] output buffers behave as open-drain outputs

**MSTR** — SPI Master/Slave Mode Select

- 0 = Slave mode
- 1 = Master mode

**CPOL, CPHA** — SPI Clock Polarity, Clock Phase

These two bits are used to specify the clock format to be used in SPI operations. When the clock polarity bit is cleared and data is not being transferred, the SCK pin of the master device is low. When CPOL is set, SCK idles high. See [Figure 22](#) and [Figure 23](#).

**SSOE** — Slave Select Output Enable

The  $\overline{SS}$  output feature is enabled only in the master mode by asserting the SSOE and DDS7.

LSBF — SPI LSB First enable

0 = Data is transferred most significant bit first

1 = Data is transferred least significant bit first

Normally data is transferred most significant bit first. This bit does not affect the position of the MSB and LSB in the data register. Reads and writes of the data register will always have MSB in bit 7.

**SP0CR2** — SPI Control Register 2

**\$00D1**

	Bit 7	6	5	4	3	2	1	Bit 0
	0	0	0	0	0	0	SSWAI	SPC0
RESET:	0	0	0	0	0	0	0	0

Read or write anytime.

SSWAI — SSI Stop in Wait Mode

0 = SSI clock operate normally

1 = Halt SSI clock generation when in Wait mode

SPC0 — Serial Pin Control 0

This bit decides serial pin configurations with MSTR control bit.

**Table 32**

Pin Mode		SPC0 <sup>(1)</sup>	MSTR	MISO <sup>(2)</sup>	MOSI <sup>(3)</sup>	SCK <sup>(4)</sup>	SS <sup>(5)</sup>
#1	Normal	0	0	Slave Out	Slave In	SCK In	SS In
#2			1	Master In	Master Out	SCK Out	SS I/O
#3	Bidirectional	1	0	Slave I/O	GPI/O	SCK In	SS In
#4			1	GPI/O	Master I/O	SCK Out	SS I/O

1. The serial pin control 0 bit enables bidirectional configurations.
2. Slave output is enabled if DDS4 = 1, SS = 0 and MSTR = 0. (#1, #3)
3. Master output is enabled if DDS5 = 1 and MSTR = 1. (#2, #4)
4. SCK output is enabled if DDS6 = 1 and MSTR = 1. (#2, #4)
5. SS output is enabled if DDS7 = 1, SSOE = 1 and MSTR = 1. (#2, #4)

Serial Interface

**SP0BR** — SPI Baud Rate Register

**\$00D2**

	Bit 7	6	5	4	3	2	1	Bit 0
	0	0	0	0	0	SPR2	SPR1	SPR0
RESET:	0	0	0	0	0	0	0	0

Read anytime. Write anytime.

At reset, E Clock divided by 2 is selected.

**SPR[2:0]** — SPI Clock (SCK) Rate Select Bits

These bits are used to specify the SPI clock rate.

**Table 33 SPI Clock Rate Selection**

SPR2	SPR1	SPR0	E Clock Divisor	Frequency at E Clock = 4 MHz	Frequency at E Clock = 8 MHz	Frequency at E Clock = 10 MHz
0	0	0	2	2.0 MHz	4.0 MHz	5.0 MHz
0	0	1	4	1.0 MHz	2.0 MHz	2.5 MHz
0	1	0	8	500 KHz	1.0 MHz	1.25 MHz
0	1	1	16	250 KHz	500 KHz	625 KHz
1	0	0	32	125 KHz	250 KHz	313 KHz
1	0	1	64	62.5 KHz	125 KHz	156 KHz
1	1	0	128	31.3 KHz	62.5 KHz	78.1 KHz
1	1	1	256	15.6 KHz	31.3 KHz	39.1 KHz

**SP0SR** — SPI Status Register

**\$00D3**

	Bit 7	6	5	4	3	2	1	Bit 0
	SPIF	WCOL	0	MODF	0	0	0	0
RESET:	0	0	0	0	0	0	0	0

Read anytime. Write has no meaning or effect.

**SPIF** — SPI Interrupt Request

SPIF is set after the eighth SCK cycle in a data transfer and it is cleared by reading the SP0SR register (with SPIF set) followed by an access (read or write) to the SPI data register.

**WCOL — Write Collision Status Flag**

The MCU write is disabled to avoid writing over the data being transferred. No interrupt is generated because the error status flag can be read upon completion of the transfer that was in progress at the time of the error. Automatically cleared by a read of the SP0SR (with WCOL set) followed by an access (read or write) to the SP0DR register.

0 = No write collision

1 = Indicates that a serial transfer was in progress when the MCU tried to write new data into the SP0DR data register.

**MODF — SPI Mode Error Interrupt Status Flag**

This bit is set automatically by SPI hardware if the MSTR control bit is set and the slave select input pin becomes zero. This condition is not permitted in normal operation. In the case where DDRS bit 7 is set, the PS7 pin is a general-purpose output pin or  $\overline{SS}$  output pin rather than being dedicated as the  $\overline{SS}$  input for the SPI system. In this special case the mode fault function is inhibited and MODF remains cleared. This flag is automatically cleared by a read of the SP0SR (with MODF set) followed by a write to the SP0CR1 register.

**SP0DR — SPI Data Register**

**\$00D5**

	Bit 7	6	5	4	3	2	1	Bit 0
RESET:	0	0	0	0	0	0	0	0

Read anytime (normally only after SPIF flag set). Write anytime (see WCOL write collision flag).

Reset does not affect this address.

This 8-bit register is both the input and output register for SPI data. Reads of this register are double buffered but writes cause data to be written directly into the serial shifter. In the SPI system the 8-bit data register in the master and the 8-bit data register in the slave are linked by the MOSI and MISO wires to form a distributed 16-bit register. When a data transfer operation is performed, this 16-bit register is serially shifted eight bit positions by the SCK clock from the master so the data is effectively exchanged between the master and the slave.

Note that some slave devices are very simple and either accept data from the master without returning data to the master or pass data to the master without requiring data from the master.

Port S

In all modes, port S bits PS[7:0] can be used for either general-purpose I/O, or with the SCI and SPI subsystems. During reset, port S pins are configured as high-impedance inputs (DDRS is cleared).

**PORTS** — Port S Data Register

**\$00D6**

	Bit 7	6	5	4	3	2	1	Bit 0
	PS7	PS6	PS5	PS4	PS3	PS2	PS1	PS0
Pin Function	SS CS	SCK	MOSI MOMI	MISO SISO	I/O	I/O	TXD0	RXD0

PORTS can be read anytime. When configured as an input, a read will return the pin level. When configured as output, a read will return the latched output data. Writes do not change pin state when pin configured for SPI or SCI output.

After reset all bits are configured as general-purpose inputs.

Port S shares function with the on-chip serial systems (SPI0 and SCI0).

**DDRS** — Data Direction Register for Port S

**\$00D7**

	Bit 7	6	5	4	3	2	1	Bit 0
	DDS7	DDS6	DDS5	DDS4	DDS3	DDS2	DDS1	DDS0
RESET:	0	0	0	0	0	0	0	0

Read or write anytime.

After reset, all general-purpose I/O are configured for input only.

0 = Configure the corresponding I/O pin for input only

1 = Configure the corresponding I/O pin for output



## DDS0 — Data Direction for Port S, Bit 0

If the SCI receiver is configured for two-wire SCI operation, corresponding port S pins will be input regardless of the state of these bits.

## DDS1 — Data Direction for Port S, Bit 1

If the SCI transmitter is configured for two-wire SCI operation, corresponding port S pins will be output regardless of the state of these bits.

## DDS[2:3] — Data Direction for Port S Bit 2 and Bit 3

These bits are for general purpose I/O only.

## DDS[6:4] — Data Direction for Port S Bits 6 through 4

If the SPI is enabled and expects the corresponding port S pin to be an input, it will be an input regardless of the state of the DDRS bit. If the SPI is enabled and expects the bit to be an output, it will be an output only if the DDRS bit is set.

## DDS7 — Data Direction for Port S Bit 7

In SPI slave mode, DDS7 has no meaning or effect; the PS7 pin is dedicated as the  $\overline{SS}$  input. In SPI master mode, DDS7 determines whether PS7 is an error detect input to the SPI or a general-purpose or slave select output line.

## PURDS — Pullup and Reduced Drive for Port S

**\$00DB**

	Bit 7	6	5	4	3	2	1	Bit 0
	0	RDPS2	RDPS1	RDPS0	0	PUPS2	PUPS1	PUPS0
RESET:	0	0	0	0	0	0	0	0

Read or write anytime.

## RDPS2 — Reduce Drive of PS[7:4]

- 0 = Port S output drivers for bits 7 through 4 operate normally.
- 1 = Port S output pins for bits 7 through 4 have reduced drive capability for lower power and less noise.

- RDPS1** — Reduce Drive of PS[3:2]  
0 = Port S output drivers for bits 3 and 2 operate normally.  
1 = Port S output pins for bits 3 and 2 have reduced drive capability for lower power and less noise.
- RDPS0** — Reduce Drive of PS[1:0]  
0 = Port S output drivers for bits 1 and 0 operate normally.  
1 = Port S output pins for bits 1 and 0 have reduced drive capability for lower power and less noise.
- PUPS2** — Pull-Up Port S Enable PS[7:4]  
0 = No internal pull-ups on port S bits 7 through 4.  
1 = Port S input pins for bits 7 through 4 have an active pull-up device. If a pin is programmed as output, the pull-up device becomes inactive.
- PUPS1** — Pull-Up Port S Enable PS[3:2]  
0 = No internal pull-ups on port S bits 3 and 2.  
1 = Port S input pins for bits 3 and 2 have an active pull-up device. If a pin is programmed as output, the pull-up device becomes inactive.
- PUPS0** — Pull-Up Port S Enable PS[1:0]  
0 = No internal pull-ups on port S bits 1 and 0.  
1 = Port S input pins for bits 1 and 0 have an active pull-up device. If a pin is programmed as output, the pull-up device becomes inactive.

# Byteflight™ Module

---

---

## Contents

Introduction .....	167
Features .....	168
External Pins .....	169
Byteflight™ System .....	169
Byteflight™ Protocol .....	171
Functional Overview .....	176
Low Power Modes .....	186
Programmer's Model .....	189
Initialization .....	216
FIFO Usage .....	217

---

---

## Introduction

The serial bus interface module is the specific implementation of the BMW Byteflight™ concept targeted for the Motorola M68HC12 microcontroller family.

For the BMW Byteflight™ specification and related matters refer to the following documents:

*BMW – Lastenheft SI-BUS , Ident-Nr.: LH 8 385 743.4*  
*ELMOS E100.34 S/E-Module, Rev. 02*

---

---

### Features

The basic features of the Serial Bus Interface are as follows:

- Modular Architecture.
- Implementation of the BMW Byteflight™ protocol.
  - 1 byte identifier.
  - 1 byte data length field (4 bits length, 4 bits reserved).
  - 0–12 bytes data.
  - 2 bytes checksum, hardware CRC generation and checking.
  - bit rate 10 Mbps.
  - no collision on the bus.
  - non-return-to-zero (NRZ) format.
- Double buffered receive storage scheme.
- 16 Message Buffers of 0–12 bytes data length.
- Programmable Message Buffer Configuration (transmit, receive, FIFO).
- Content-related addressing.
- Receive FIFO for bus monitoring with programmable acceptance filter.
- 11 maskable interrupt sources, generating five CPU interrupt vectors.
- Programmable bus master function.
- Programmable wake-up function.
- Low power sleep mode.

---

---

## External Pins

The serial bus interface module uses 2 external pins, 1 input (Rx) and 1 output (Tx).

Rx is on bit 0 of Port SBI, Tx is on bit 1. The remaining six signals of Port SBI are controlled by registers in the Byteflight™ address map

**NOTE:** *Depending on the chip package, not all Port SBI signals may be available.*

---

---

## Byteflight™ System

A typical Byteflight™ system with the serial bus interface is shown in [Figure 25](#) below.

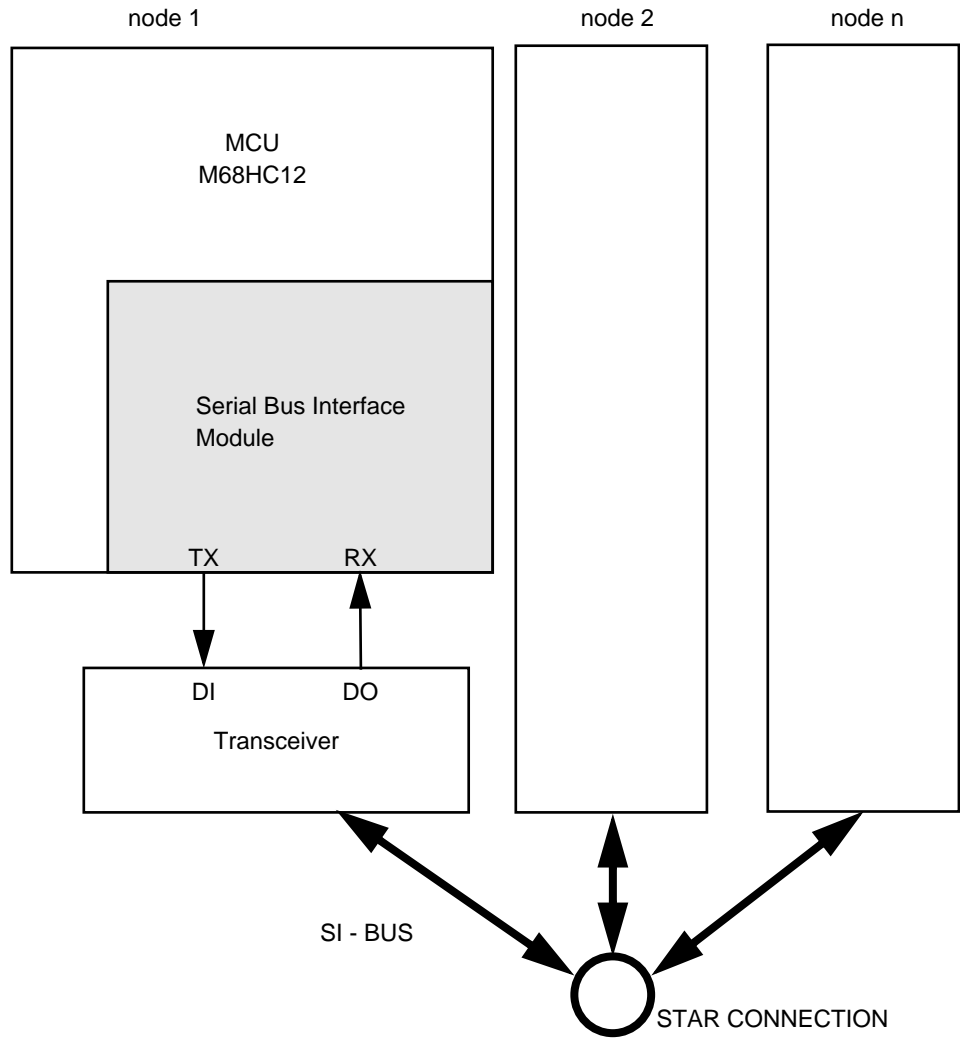
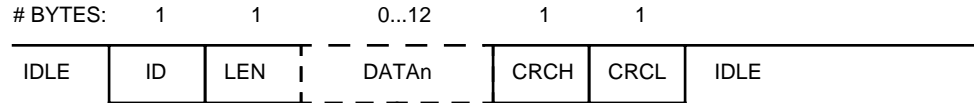

Figure 25 Byteflight™ System

Each node is connected physically to the Byteflight™ through a special transceiver chip. All nodes are connected by a star configuration. The propagation times between each different node and the star can be different.

Byteflight™ Protocol

**Byteflight™ Format and Timing** The BMW Byteflight™ protocol defines the message format, as follows:



**Figure 26 Byteflight™ Message Format**

The identifier (ID) byte is followed by the length (LEN) byte, which contains the number of data bytes (0..12) of the message. Following the data bytes (DATAn) are two CRC bytes (CRCH,CRCL), which contain the checksum. The value zero is not allowed for any identifier (ID). The priority of an identifier is inversely proportional to its value.

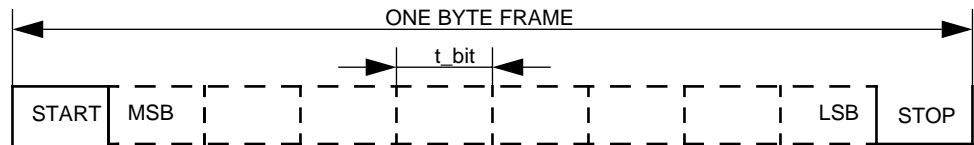

**Figure 27 Byteflight™ Byte Format**

One byte of a message is embedded into a start bit ('1') and a stop bit ('0'), which are synchronization symbols and distinguish a message from a SYNC pulse. The transfer starts with the MSB first. The dominant state is represented by a logical '0' and the recessive state is represented by a logical '1'.

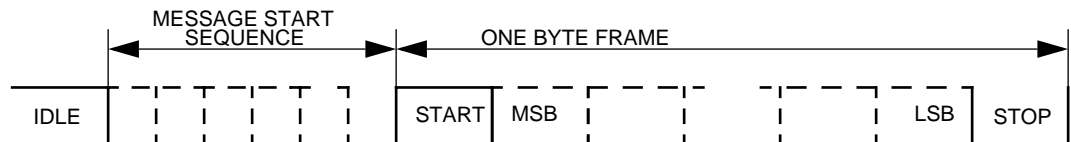

**Figure 28 Byteflight™ Message Start Sequence**

Every transmitted message contains an additional message start sequence of 6 bits logic '0' followed by the startbit ('1') of the first byte. The receiver must recognize at least one bit ('0') of the start sequence and the following startbit ('1').

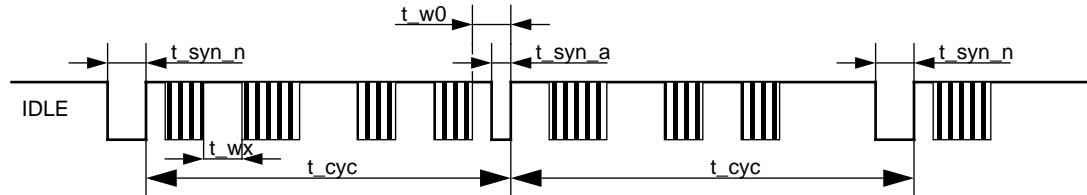

Figure 29 Byteflight™ Cycle Timing

The current bus master generates periodic synchronization (SYNC) pulses in the cycle of  $t_{cyc}$ . There are two types of SYNC pulses, the normal SYNC pulse with a duration of  $t_{syn\_n}$  and the ALARM pulse with the duration of  $t_{syn\_a}$ .

Every node can be configured as bus master by software. In the Byteflight™ system only one bus master should exist. All other nodes are bus slaves and use the SYNC pulses for their internal synchronization. The bus master and the bus slaves can send and receive messages in the communication cycle, which is the time between the SYNC pulses.

The order of the messages is determined by their priorities which are given by their identifiers ID (highest priority = lowest identifier). Every identifier can appear only once during a cycle. This warrants that a certain amount of high priority messages can be transferred, the bus cannot be occupied by the message with the highest priority.

Based on TCR1, TCR2, TCR3 (Table 34) a slot counter is running after a sync pulse was transmitted (master) or received (slave).

Master:

From sync pulse:  $TCR1 + TCR3$ : slot counter becomes 1

From sync pulse:  $TCR1 + 2*TCR3$ : slot counter becomes 2

Form sync pulse:  $TCR1 + 3*TCR3$ : slot counter becomes 3



Slave:

From sync pulse:  $TCR2 + TCR3$ : slot counter becomes 1

From sync pulse:  $TCR2 + 2*TCR3$ : slot counter becomes 2

Form sync pulse:  $TCR2 + 3*TCR3$ : slot counter becomes 3

When a node wants to transmit e.g. ID=2 and the slot counter reaches the value 2, the node starts to transmit and stops the slot counter. All other nodes receive that message in time slot = 2 and also stop their slot counters as soon as they detect bus activity. When a rising edge (e.g. end of message) on the bus is detected the wait time is calculated again, i.e. the slot counter is incremented again after  $TCR1+TCR3$  (last bus activity was transmitted) or  $TCR2+TCR3$  (last bus activity was received):

Assuming that a message with ID = 2 was received or transmitted in the time slot = 2 the slot counter is restarted in the following way:

Last bus activity was transmitted:

Waiting from rising edge:  $TCR1 + TCR3$ : slot counter is incremented by one.

$TCR3$  later: slot counter is incremented again.

Last bus activity was received:

Waiting from rising edge:  $TCR12+ TCR3$ : slot counter is incremented by one.

$TCR3$  later: slot counter is incremented again.

## Cyclic Redundancy Check c(CRC)

Every message transmitted onto a Byteflight™ network contains two CRC bytes for error detection. These two bytes are produced by shifting the ID, LEN and DATA bytes through a preset series of feedback shift registers (For more details refer to *BMW – Lastenheft SI-Bus*). The 15-bit CRC result is appended to the message following the data portion. The byte CRCH contains the upper 8 bits of the CRC result, the byte CRCL contains the lower 7 bits, the LSB of CRCL is set to '0'.

Any node which receives the message recalculates the CRC value with the same hardware and compares bitwise the result against the received CRC value. In the case of a mismatch a CRC Error is detected.

Byteflight™ Timing  
Parameters

Table 34 Parameter of the Byteflight™ System

Symbol	Characteristic	Description	Typ
t_bit	bit time	time for the transmission of one bit, defined by the physical limitations of the system	100 ns
t_cyc	cycle time (note 2)	time distance between the end of the SYNC pulses	250 μs <sup>(1)</sup>
t_cyc_min	min cycle time	min time distance between the end of the SYNC pulses	249.725μs
t_cyc_max	max cycle time	max time distance between the end of the SYNC pulses	250.275μs
t_max	maximum run time of a signal in the bus system	max run time of a signal between a transmit module and the recognition by a receive module	tbd, ca 400ns
t_tolerance	tolerance of the run time of a signal in the bus system	is the sum of all tolerances	tbd, ca 300ns
t_idle_min	min bus idle time	min bus idle time between two messages or the SYNC pulse and a message	11 * t_bit
t_syn_a	Sync pulse ALARM	duration of the Sync pulse in the case of ALARM	2 μs <sup>(2)</sup>
t_syn_a_min	Sync pulse ALARM, min pulse width	min duration of the Sync pulse in the case of ALARM	1.85 μs
t_syn_a_max	Sync pulse ALARM, max pulse width	max duration of the Sync pulse in the case of ALARM	2.15 μs
t_syn_n	Sync pulse NORMAL	duration of the Sync pulse in the normal case	3 μs <sup>(3)</sup>
t_syn_n_min	Sync pulse NORMAL, min pulse width	min duration of the Sync pulse in the normal case	2.85 μs
t_syn_n_max	Sync pulse NORMAL, max pulse width	max duration of the Sync pulse in the normal case	3.15 μs
t_w0	Sync pulse wait time	minimum time between end of a message and end of SYNC pulse, t_w0 >= t_idle_min + t_syn_n_max	< 6000ns
ID	Identifier	allowed values between 1 .. 255	
ID <sub>x-1</sub>	previous Identifier	Identifier of the previously received or transmitted message. When the Sync pulse was the last activity on the bus, then ID <sub>x-1</sub> = 0	

Table 34 Parameter of the Byteflight™ System

Symbol	Characteristic	Description	Typ
t_wx	message idle time	time between the end of the Sync pulse or end of the previous message and the start of the transmitted message. t_wx >= t_idle_min  t_wx = twx0_tx + twx_delta * (ID - IDx-1), when the node sent the last activity on the bus  t_wx = twx0_rx + twx_delta * (ID - IDx-1), when the node received the last activity on the bus	
t_wx0_tx	constant part of t_wx when last bus activity was transmitted	t_wx0_tx can be programmed individually for each node in the register TCR1	<1900ns
t_wx0_rx	constant part of t_wx when last bus activity was received	t_wx0_rx can be programmed individually for each node in the register TCR2	<1900ns
t_latest_tx	latest start of transmit	t_latest_tx is currently hard wired	229.0 μs
t_start_seq_tx	length of tx start sequence	t_start_seq_tx is currently hard wired	600ns
t_start_seq_rx	length of rx start sequence (max)	t_start_seq_rx is currently hard wired	975ns
t_start_seq_rx	length of rx start sequence (min)	t_start_seq_rx is currently hard wired	100ns
t_wx_delta	multiplier part of t_wx	this value must be assigned identically for each node using register TCR3. t_wx_delta = t_max + t_tolerance	< 1200ns > 200ns
t_recognize	recognition time for bus activity	time required for recognition of bus activity: time from falling edge of RX pin until the bus controller can stop a waiting transmit process	<125ns
t_wake_up	length of wake up pulse	a sequence of dominant and recessive pulses of length t_wake_up is sent out if WPULSE is set	6.4 μs

1.  $249.75\mu s \leq t_{cyc} \leq 250.25\mu s$  in 100% of cases there is no error,  $t_{cyc} < 249.7\mu s$  or  $t_{cyc} > 250.3\mu s$  in 100% of cases sync too early/ lost
2.  $1.875\mu s \leq t_{syn\_a} \leq 2.125\mu s$  in 100% of cases sync alarm is accepted,  $t_{syn\_a} < 1.825\mu s$  or  $t_{syn\_a} > 2.175\mu s$  in 100% of sync alarm is not accepted, but illegal pulse is detected
3.  $2.875\mu s \leq t_{syn\_n} \leq 3.125\mu s$  in 100% of cases sync normal is accepted,  $t_{syn\_n} < 2.825\mu s$  or  $t_{syn\_n} > 3.175\mu s$  in 100% of sync normal is not accepted, but illegal pulse is detected

Tolerances

The receiver is designed to handle signals on the Byteflight™ with the tolerances shown in Figure 30 and in Table 35.

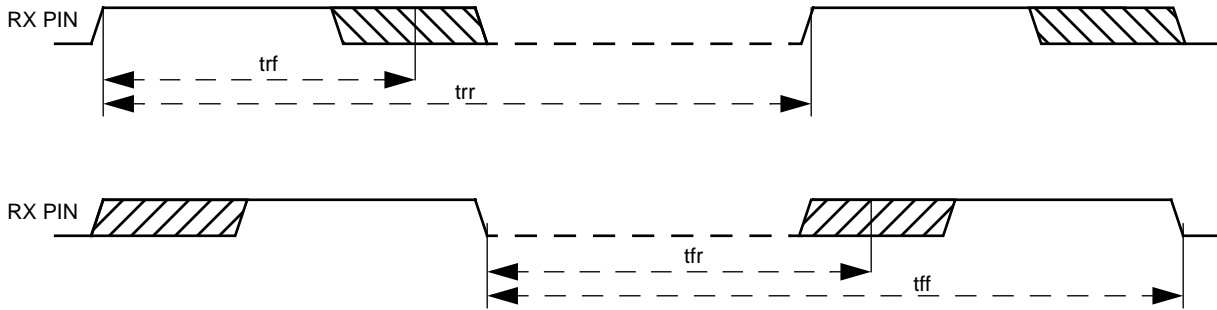

Figure 30 Pulse Time Tolerance

Table 35 Tolerances

Tolerance		Range
t <sub>rr</sub>	$n * t_{bit} \pm 5ns$	$2 \leq n \leq 10$
t <sub>ff</sub>	$n * t_{bit} \pm 5ns$	$2 \leq n \leq 10$
t <sub>rf</sub>	$n * t_{bit} \pm 35ns$	$1 \leq n \leq 10$
t <sub>fr</sub>	$n * t_{bit} \pm 35ns$	$1 \leq n \leq 10$

Glitch Filtering

Glitches of a duration less than 25ns are filtered out.

---



---

Functional Overview

Recieve Process

A part or all of the message buffers can be configured as a mailbox system consisting of dedicated receive buffers. The mailbox must be contiguous in the register map starting after the last FIFO buffer and ending before the first transmit buffer. The Byteflight™ transfers received messages from the serial message buffer to the mailbox message buffer with matching ID.

To prepare or change a message buffer for reception the following steps in soft reset mode are required:

- Lock the corresponding message buffer in order to appear in the Active Receive Buffer window in the memory map.
- Wait for lock acknowledge.
- Write the matching ID to this Active Receive Buffer.
- Clear the IFLG (buffer empty) by writing a '1' to it.

**NOTE:** *It is recommended to split clearing of the IFLG and unlocking the message buffer into two separate instructions, i.e. clear the IFLG and then unlock the buffer.*

Once these steps are performed, the message buffer functions as an active receive buffer and participates in the internal matching process, which takes place every time the Byteflight™ receives a message. In this process, all active receive buffers compare their ID value to the newly received one. The buffer matching the received ID will be updated with the new message at the end of reception if the buffer is not locked. The matching buffer will be overwritten if the buffer was already full (IFLG = 1). The matching buffer will not be updated if it is still locked. The buffer will be updated as soon as it is unlocked. If the buffer is locked for more than one cycle and if the same ID is received twice during this period, the buffer will be updated with the newer message as soon as it is unlocked.

The corresponding IFLG flag (buffer full) is set every time the buffer is updated, and if enabled a receive interrupt is generated. Erroneous messages will be ignored and will not overwrite unlocked full buffers. Only unique IDs must be used. ID '0' should be used to deactivate a receive buffer.

To read a receive message buffer the following steps are required:

- Lock the corresponding message buffer in order to appear in the Active Receive Buffer window in the memory map.
- Wait for lock acknowledge.
- Read the Active Receive Buffer.

- Clear the IFLG (buffer empty) by writing a '1' to it.
- Unlock the message buffer.

**NOTE:** *Bit manipulation instructions (BSET or BCLR) shall not be used to clear interrupt flags.*

### Receive FIFO Function

A part or all of the message buffers can be configured to a Receive First-In-First-Out (FIFO) System, which can be used as logic analyzer buffers or for receiving consecutive data streams.

The FIFO starts with message buffer 0 and can be configured to the maximum of all 16 message buffers. Every incoming message not matching with any receive identifier but matching the programmable FIFO filter is stored into the FIFO buffer system. A status bit shows that the Receive FIFO is not empty, another status bit shows that a Receive FIFO Overrun has been detected. If enabled, interrupts are generated.

There are two index registers associated with the FIFO. The PUT Index Register (PUTIDX) is used as an index to the next available location in the FIFO buffer system. When a new message has been received it is written into the buffer addressed by the PUTIDX; the PUTIDX is then incremented so it addresses the next buffer. If the PUTIDX is incremented past the highest FIFO message buffer the PUTIDX is reset to 0. The GET Index Register (GETIDX) is used to address the next FIFO buffer to be read. The GETIDX is incremented when unlocking the Receive FIFO buffer. The FIFO buffer system is completely filled, when the PUT Pointer (PUTIDX) has reached again the value of the GET Pointer (GETIDX). A new incoming messages cannot be stored into the FIFO. The FIFO overrun flag is set at the end of this message if no error has occurred. A Receive FIFO non empty status is detected when the PUTIDX differs from the GETIDX. This indicates there is at least one received message in the FIFO buffer system. The PUTIDX and the GETIDX are not addressable by the CPU.

The FIFO empty, FIFO not empty and the FIFO overrun situations are explained in [Figure 31](#) below for a three buffer FIFO.

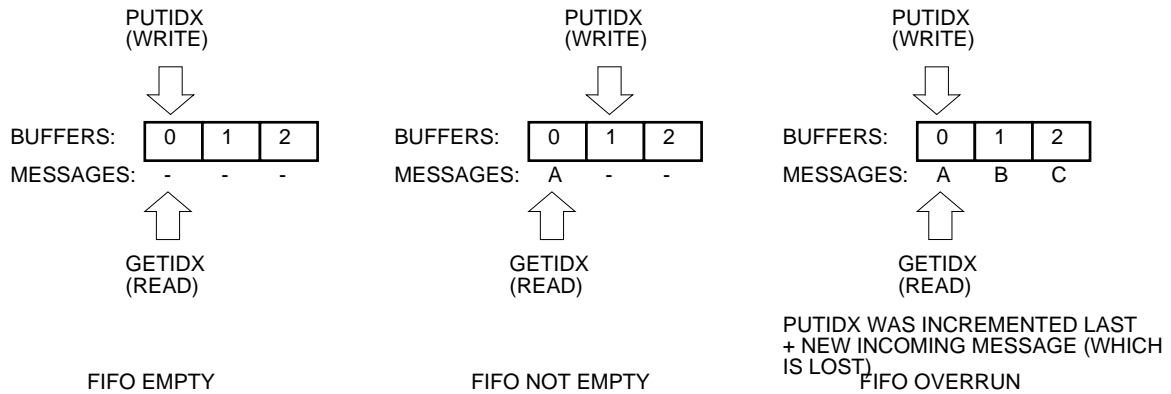

**Figure 31 FIFO Status (empty, not empty, overrun) - Example with 3 buffers**

To read a Receive FIFO buffer the FIFO must be locked by setting the LOCK bit of buffer 0. The message buffer addressed by GETIDX appears in the Active Receive FIFO Buffer window in the memory map. After reading the FIFO must be unlocked and the GETIDX will be incremented.

There is a programmable identifier acceptance filter for the Receive FIFO system. The FIFO identifier acceptance register (FIDAC) defines the acceptable pattern of the identifier to be received. The FIFO identifier mask register (FIDMR) specifies which of the corresponding bits are marked 'don't care' for acceptance filtering.

There is also a programmable identifier rejection filter for the Receive FIFO system. The FIFO identifier rejection register (FIDRJ) defines the acceptable pattern of the identifier to be rejected. The FIFO identifier rejection mask register (FIDRMR) specifies which of the corresponding bits are marked 'don't care' for rejection filtering.

If acceptance and rejection filter are configured to match the same identifier, the message will be rejected.

**Table 36 Acceptance/rejection filter mechanism - Examples**

	Example 1 <sup>(1)</sup>	Example 2 <sup>(2)</sup>	Example 3 <sup>(3)</sup>	Example 4 <sup>(4)</sup>
FIDAR	\$00	\$55	\$xx	%0xxx xxxx
FIDMR	\$00	\$00	\$FF	%0111 1111
FIDRJ	\$xx	\$55	\$0x	%xx11 xxxx
FIDRMR	\$FF	\$00	\$0F	%1100 1111
Stage I: Accept ID	\$00	\$55	\$00...\$FF	\$00...\$7F
Stage II: Reject ID	none	\$55	\$00...\$0F	\$30...\$3F \$70...\$7F
Receive ID	\$00	none	\$10...\$FF	\$00...\$2F \$40...\$6F

1. All registers in reset state: Do not accept any valid system ID (\$01...\$FF).
2. Acceptance and rejection filter set to match same ID: Do not accept ID's other than \$55, then reject \$55.
3. Accept all ID's (\$00 no valid system ID), then reject all ID's with high nibble=0.
4. Do not accept ID's \$80 to \$FF, accept all \$00 to \$7F (\$00 no valid system ID), then reject all ID's with bit 4 and 5 set.

**Transmit Process**

A part or all of the message buffers can be configured as transmit buffers. The set of transmit buffers must be contiguous in the register map starting at buffer 15 and ending before the first receive buffer. A message is submitted for transmission by unlocking the corresponding non-empty (IFLG = 0) transmit buffer. The transmit buffer remains active until the message is transmitted or aborted.

If there are several messages pending for transmission within the interface, the message with the highest priority (lowest identifier) is selected next. Only transmit buffers which were unlocked and full before a sync pulse are transmitted in the following cycle. If there are two or more transmit buffers with the same identifier, the buffer with the lowest address wins the internal arbitration and will be transmitted, the remaining buffer(s) with the same ID will be removed from the arbitration process until the next communication cycle. A full buffer can be aborted by setting the corresponding abort request bit. At the next sync pulse the interrupt status flag (buffer is empty) and the abort acknowledge flag are set if the buffer has been aborted. Only the interrupt status flag is set if the buffer has been sent out.



To prepare a transmit message buffer for transmission the following steps are required:

- Lock the corresponding message buffer in order to appear in the Active Transmit Buffer window in the memory map.
- Wait for lock acknowledge.
- Write to the Active Transmit Buffer (ID, LEN, DATA). If no update is needed, write is not required.
- Unlock the message buffer and clear the IFLG (buffer full) by writing a '1' to it.

**NOTE:** *Bit manipulation instructions (BSET or BCLR) shall not be used to clear interrupt flags.  
It is recommended to use one single instruction to clear the IFLG and to unlock the buffer.*

## Synchronization Process

The node can be configured as bus master. In this case the module generates the periodic synchronization (SYNC) pulses. If the ALARM bit is set, the master generates the ALARM pulses as long as this bit is asserted. The ALARM bit is reset after 255ms - 256ms if it has not been set again by the CPU within that period.

**Error Handling** The serial bus interface module detects and handles the following types of errors:

**Table 37 Error Handling**

Error Type	Error Description	Error Handling
Message Format Error	Incorrect CRC, incorrect START bit or STOP bit (Frame), missing or corrupted message start sequence, bus-activity during the bus idle time or before expiry of (t_cyc_min - t_syn_n) since the last correct sync pulse: dominant pulse of length t: t_start_seq < t < t_syn_a_min	The node is still synchronized. Transmission and reception is possible after t_idle_min. Set flag and generate interrupt if enabled.
SYNC Pulse Too Early Error	A pulse has not the required position of an ALARM or NORMAL pulse, the pulse appears too early	SYNC pulse is used for synchronization. Set flag and generate interrupt if enabled.
SYNC Pulse Lost Error	No valid SYNC pulse detected until end of cycle t_cyc_max	No transmission or reception until the next correct SYNC pulse. Set flag and generate interrupt if enabled.
Illegal Pulse Error	Before expiry of (t_cyc_min - t_syn_n) since the last correct sync pulse: dominant pulse of length t detected on the bus: t_syn_a_max < t < t_syn_n_min or t > t_syn_n_max after expiry of (t_cyc_min - t_syn_n) since the last correct sync pulse: all dominant pulses which are not correct sync-normal or sync-alarm pulses lead to this error	No transmission or reception until the next correct SYNC pulse. Set flag and generate interrupt if enabled.

The Rx pin of the serial bus interface module is internally connected to its own Tx pin during Tx activity and for 8\*t\_bit after last Tx activity (to avoid receiving of echoes).

**SYNC Pulse Detection** A Sync Pulse is defined as a continuous dominant pulse with :

$$t\_syn\_a\_min < t\_syn\_a < t\_syn\_a\_max \text{ or}$$

$$t\_syn\_n\_min < t\_syn\_n < t\_syn\_n\_max$$

Any dominant pulse within the wait times t\_wx, t\_w0 - t\_syn\_n\_max is considered as an error. If this pulse has a valid SYNC length the cycle is restarted and a SYNC too early error is set. If the pulse has not a valid length an illegal pulse error or a message format error is issued (see

Table 37). A valid synchronization edge is detected if the pulse length is correct independent of the pulse position. If the pulse position is not correct either a pulse too early or a sync lost error condition is set. ALARM and NORMAL SYNC are distinguished only by the bits SYNAIF and SYNNAIF.

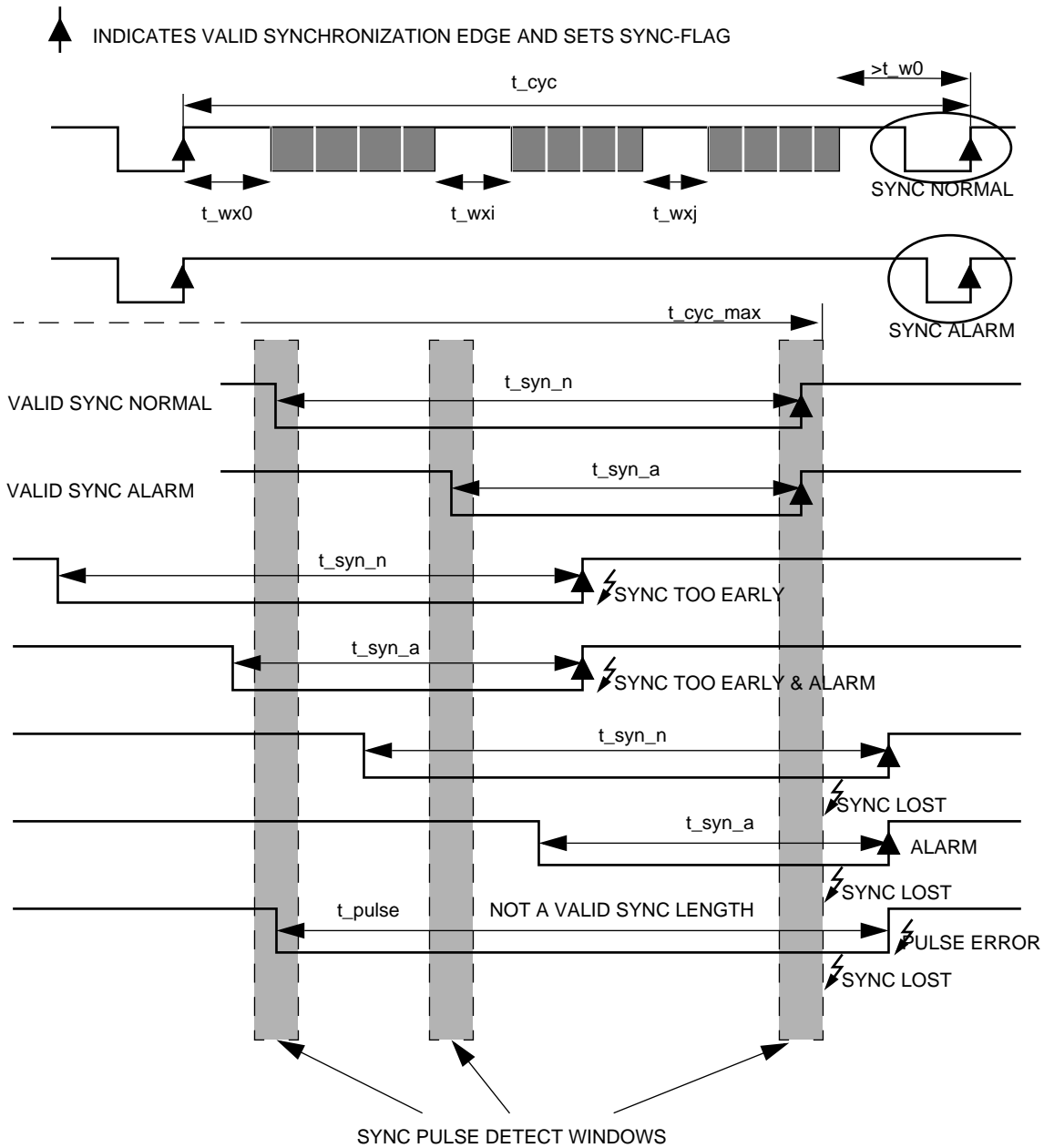

Figure 32 SYNC Pulse Errors Detection

### Interrupts

The Serial Bus Interface module is capable of generating five different interrupt requests (vectors) mapped onto different interrupt sources:

1. SYNC pulse interrupt at high priority (SYNC pulse NORMAL or ALARM received)
2. Receive FIFO not empty
3. Receive Interrupt
4. Synchronization Interrupt (SYNC pulse NORMAL or ALARM received)
5. General Interrupt (all errors, transmit and other interrupt sources)
  - Transmit Interrupt
  - Receive FIFO overrun
  - Message Format Error (CRC Error, Frame Error)
  - SYNC Pulse To Early Error
  - SYNC Pulse Lost Error
  - Illegal Pulse Error
  - Wake-Up Interrupt
  - Locking Error Interrupt
  - Slot Mismatch Interrupt

**Table 38 Module Interrupt Vectors**

Function	Source	Local Mask	Global Mask
High priority SYNC pulse interrupt	XSYNIF	XSYNIE	X Bit <sup>(1)</sup>
FIFO Not Empty Interrupt	RCVFIF	RCVFIE	I Bit <sup>(2)</sup>
Receive Interrupt	IFLG [15..0] (RX)	IENA [15:0]	
Synchronization Interrupt	SYNAIF	SYNAIE	
	SYNNIF	SYNNIE	
General Interrupt	IFLG [15..0] (TX)	IENA [15:0]	
	OVNIF	OVRNIE	
	ERRIF	ERRIE	
	SYNEIF	SYNEIE	
	SYNLIF	SYNLIE	
	ILLPIF	ILLPIE	
	WAKEIF	WAKEIE	
LOCKIF	LOCKIE		
SLMMIF	SLMMIE		

1. The X Bit in the condition code register (CCR) is the interrupt mask for the XIRQ pin
2. The I Bit in the condition code register (CCR) is the global interrupt mask for all HC12 CPU interrupts.

**NOTE:** *Bit manipulation instructions (BSET or BCLR) shall not be used to clear interrupt flags.*

**Wakeup**

The serial bus interface module is able to wake-up from CPU STOP mode or Module SLEEP mode by the recognition of a falling edge at the input Rx. The local mask for the wakeup interrupt is the Wakeup Interrupt Enable bit (WAKEIE). After wake-up a node configured as Master should start to send SYNC pulses during *tsl\_min* (refer to transceiver spec ELMOS 100.34) in order to avoid that the transceiver enters sleep mode again.

## Low Power Modes

In addition to normal mode, the Serial Bus Interface module has three modes with reduced power consumption: Sleep, Soft Reset and Power Save mode. In Sleep and Soft Reset mode, power consumption is reduced by stopping all clocks except those to access the register. In Power Save mode, all clocks are stopped and no power is consumed (except leakage current).

The WAI and STOP instruction put the MCU in low power consumption stand-by modes. Table 39 summarizes the combinations of Byteflight™ and CPU modes. A particular combination of modes is entered for the given settings of the bits SSWAI, SLPK, and SFTRES. For all modes, an Byteflight™ wake-up interrupt can occur only if SLPK=WAKEIE=1. While the CPU is in Wait mode, the Byteflight™ can be operated in normal mode and generate interrupts. Registers can still be accessed via background debug mode.

**Table 39 Byteflight™ vs. CPU operating modes**

Byteflight™ Mode	CPU Mode		
	STOP	WAIT	RUN
Power Save	SSWAI = X <sup>(1)</sup> SLPAK = X SFTRES = X	SSWAI = 1 SLPAK = X SFTRES = X	
Sleep		SSWAI = 0 SLPAK = 1 SFTRES = 0	SSWAI = X SLPAK = 1 SFTRES = 0
Soft Reset		SSWAI = 0 SLPAK = 0 SFTRES = 1	SSWAI = X SLPAK = 0 SFTRES = 1
Normal		SSWAI = 0 SLPAK = 0 SFTRES = 0	SSWAI = X SLPAK = 0 SFTRES = 0

1. 'X' means don't care.

Module Sleep  
Mode

The CPU can request the Byteflight™ to enter this low-power mode by asserting the SLPRQ bit in the Module Configuration Register. The time when the Byteflight™ enters Sleep Mode depends on its activity:

- if it is transmitting, it continues to transmit until there is no more message to be transmitted, and then goes into Sleep Mode.
- if it is receiving, it waits for the end of this message and then goes into Sleep Mode.
- if it is neither transmitting nor receiving, it immediately goes into Sleep Mode.

**NOTE:** *The application software must avoid setting up a transmission (by clearing one or more IFLG flag(s)) and immediately request Sleep Mode (by setting SLPRQ). It then depends on the exact sequence of operations whether the Byteflight™ starts transmitting or goes into Sleep Mode directly. The application software should use SLPK as a handshake indication for the request (SLPRQ) to go into Sleep Mode.*

During Sleep Mode, the SLPK flag is set. When in Sleep Mode, the Byteflight™ stops its internal clocks. However, clocks to allow register accesses still run. The Tx pin stays in recessive state. It is possible to access locked transmit and receive buffers but no message abort and buffer lock/unlock takes place while in sleep mode.

The Byteflight™ leaves Sleep Mode (wake-up) when

- bus activity occurs or
- the MCU clears the SLPRQ or
- the MCU sets SFTRES.

**NOTE:** *The MCU cannot clear the SLPRQ bit before the Byteflight™ is in Sleep Mode (SLPK = 1).*

After wake-up, the Byteflight™ waits for a sync pulse to synchronize to the bus. As a consequence, if the Byteflight™ is woken-up by a valid message, this message is not received. The receive message buffer content is not affected by sleep-mode. All pending actions are executed upon wake-up: message aborts, buffer lock and message transmissions.

## Byteflight™ Module

- CPU WAIT Mode**      The WAIT instruction places the MCU in the low-power consumption WAIT mode. Depends on the SSWAI-bit the module can be stopped or remains active during CPU wait mode. When SSWAI is cleared the module will stay synchronized to the Byteflight™ and can generate interrupts to the CPU if enabled. Any such interrupt will bring the MCU out of wait mode.
- CPU STOP Mode**      A CPU STOP instruction stops the internal oscillator and halts all internal processing. The application software has to bring the module into the module sleep mode before the CPU STOP instruction is executed if the Byteflight™ has to wake up the CPU. The processor can be brought out of the STOP mode only by an external interrupt,  $\overline{\text{RESET}}$  or WAKEUP interrupt of the module.
- SOFT RESET Mode**      In Soft Reset Mode, the Byteflight™ module is stopped. Registers can still be accessed. This mode is used to initialize the module configuration.
- When setting the SFTRES bit, the Byteflight™ module immediately stops all ongoing transmission and reception, potentially causing protocol violations. The user is required to take care that the Byteflight™ is not active when Soft Reset Mode is entered. The recommended procedure is to bring the Byteflight™ module into Sleep Mode before the SFTRES bit is set.



Programmer's Model

This section describes the content and use of the registers in the serial bus interface module. An overview of all registers is shown in Figure 33.

There are three sets of registers which are accessible by the CPU:

- the general control registers,
- the 16 buffer control registers,
- and the 16 configurable message buffers with one 14 bytes active transmit buffer, one 14 bytes active receive buffer and one 14 bytes active receive FIFO buffer mirrored to the memory map.

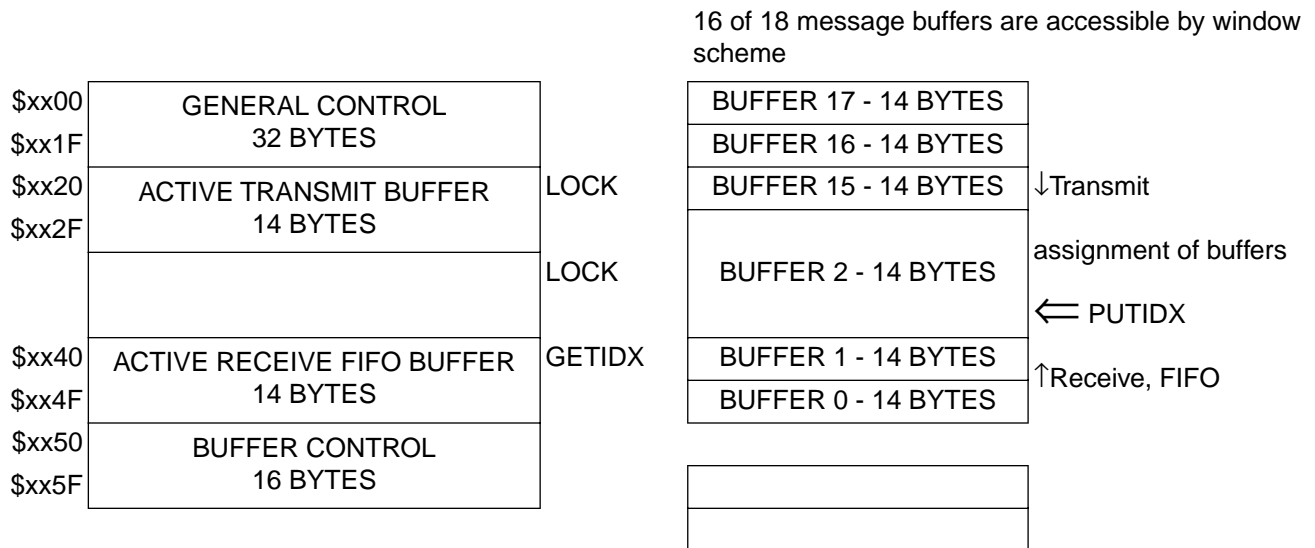

Figure 33 Register Map

Byteflight™ Module

Overview of All Registers

**NOTE:** All register bits marked by “\*” can be updated during soft reset only!

ADDR	REGISTER	R/W	BIT 7	BIT 6	BIT 5	BIT 4	BIT 3	BIT 2	BIT 1	BIT 0
\$xx00	MCR	R W	SFTRES	MASTER*	ALARM	SLPAK	SLPRQ	WPULSE*	SSWAI	0
\$xx01	FSIZR	R W	0	0	0	FSIZ4*	FSIZ3*	FSIZ2*	FSIZ1*	FSIZ0*
\$xx02	TCR1	R W	TWX0T7*	TWX0T6*	TWX0T5*	TWX0T4*	TWX0T3*	TWX0T2*	TWX0T1*	TWX0T0*
\$xx03	TCR2	R W	TWX0R7*	TWX0R6*	TWX0R5*	TWX0R4*	TWX0R3*	TWX0R2*	TWX0R1*	TWX0R0*
\$xx04	TCR3	R W	TWXD7*	TWXD6*	TWXD5*	TWXD4*	TWXD3*	TWXD2*	TWXD1*	TWXD0*
\$xx05	RESERVED FOR TEST	R W								
\$xx06	RISR	R W	RCVFIF	RXIF	SYNAIF	SYNNIF	SLMMIF	0	XSYNIF	OPTDF
\$xx07	GISR	R W	TXIF	OVRNIF	ERRIF	SYNEIF	SYNLIF	ILLPIF	LOCKIF	WAKEIF
\$xx08	RIER	R W	RCVFIE	RXIE	SYNAIE	SYNNIE	SLMMIE	0	XSYNIE	0
\$xx09	GIER	R W	TXIE	OVRNIE	ERRIE	SYNEIE	SYNLIE	ILLPIE	LOCKIE*	WAKEIE
\$xx0A	RIVEC	R W	0	0	0	0	RIVEC3	RIVEC2	RIVEC1	RIVEC0
\$xx0B	TIVEC	R W	0	0	0	0	TIVEC3	TIVEC2	TIVEC1	TIVEC0
\$xx0C	FIDAC	R W	FIDAC7*	FIDAC6*	FIDAC5*	FIDAC4*	FIDAC3*	FIDAC2*	FIDAC1*	FIDAC0*
\$xx0D	FIDMR	R W	FIDMR7*	FIDMR6*	FIDMR5*	FIDMR4*	FIDMR3*	FIDMR2*	FIDMR1*	FIDMR0*
\$xx0E	MVR	R W	MVR7	MVR6	MVR5	MVR4	MVR3	MVR2	MVR1	MVR0
\$xx0F	RESERVED FOR TEST	R W								

Table 40 General Control Registers \$xx00–\$xx0F

ADDR	REGISTER	R/W	BIT 7	BIT 6	BIT 5	BIT 4	BIT 3	BIT 2	BIT 1	BIT 0
\$xx10	PCTLSBI		PMEREN	0	PSLMEN	PERREN	PROKEN	PSYNEN	PUESBI	RDRSBI
\$xx11	PORTSBI	R W	PSBI7	PSBI6	PSBI5	PSBI4	PSBI3	PSBI2	TX	RX
\$xx12	DDRSBI	R W	DDRSBI7	DDRSBI6	DDRSBI5	DDRSBI4	DDRSBI3	DDRSBI2	0	0
\$xx13	RESERVED FOR TEST	R W								
\$xx14	FIDRJ	R W	FIDRJ7*	FIDRJ6*	FIDRJ5*	FIDRJ4*	FIDRJ3*	FIDRJ2*	FIDRJ1*	FIDRJ0*
\$xx15	FIDRMR	R W	FIDRMR7*	FIDRMR6*	FIDRMR5*	FIDRMR4*	FIDRMR3*	FIDRMR2*	FIDRMR1*	FIDRMR0*
\$xx16	RESERVED FOR TEST	R W								
\$xx17	RESERVED FOR TEST	R W								
\$xx18	RESERVED FOR TEST	R W								
\$xx19	RESERVED FOR TEST	R W								
\$xx1A	RESERVED FOR TEST	R W								
\$xx1B	RESERVED FOR TEST	R W								
\$xx1C	RESERVED FOR TEST	R W								
\$xx1D	RESERVED FOR TEST	R W								
\$xx1E	RESERVED FOR TEST	R W								
\$xx1F	RESERVED FOR TEST	R W								

**Table 41 General Control Registers \$xx10 –\$xx1F**

ADDR	REGISTER	R/W	BIT 7	BIT 6	BIT 5	BIT 4	BIT 3	BIT 2	BIT 1	BIT 0
\$xx20	TIDENT	R W	ID7	ID6	ID5	ID4	ID3	ID2	ID1	ID0
\$xx21	TLEN	R W	reserved	reserved	reserved	reserved	LEN3	LEN2	LEN1	LEN0
\$xx22	TDATA0	R W	D7	D6	D5	D4	D3	D2	D1	D0
\$xx23	TDATA1	R W	D7	D6	D5	D4	D3	D2	D1	D0
\$xx24	TDATA2	R W	D7	D6	D5	D4	D3	D2	D1	D0
\$xx25	TDATA3	R W	D7	D6	D5	D4	D3	D2	D1	D0
\$xx26	TDATA4	R W	D7	D6	D5	D4	D3	D2	D1	D0
\$xx27	TDATA5	R W	D7	D6	D5	D4	D3	D2	D1	D0
\$xx28	TDATA6	R W	D7	D6	D5	D4	D3	D2	D1	D0
\$xx29	TDATA7	R W	D7	D6	D5	D4	D3	D2	D1	D0
\$xx2A	TDATA8	R W	D7	D6	D5	D4	D3	D2	D1	D0
\$xx2B	TDATA9	R W	D7	D6	D5	D4	D3	D2	D1	D0
\$xx2C	TDATA10	R W	D7	D6	D5	D4	D3	D2	D1	D0
\$xx2D	TDATA11	R W	D7	D6	D5	D4	D3	D2	D1	D0
\$xx2E	UNIMPLEMENTED	R W								
\$xx2F	UNIMPLEMENTED	R W								

Table 42 Active Transmit Buffer Registers \$xx20–\$xx2F

ADDR	REGISTER	R/W	BIT 7	BIT 6	BIT 5	BIT 4	BIT 3	BIT 2	BIT 1	BIT 0
\$xx30	RIDENT*	R W	ID7	ID6	ID5	ID4	ID3	ID2	ID1	ID0
\$xx31	RLEN*	R W	reserved	reserved	reserved	reserved	LEN3	LEN2	LEN1	LEN0
\$xx32	RDATA0*	R W	D7	D6	D5	D4	D3	D2	D1	D0
\$xx33	RDATA1*	R W	D7	D6	D5	D4	D3	D2	D1	D0
\$xx34	RDATA2*	R W	D7	D6	D5	D4	D3	D2	D1	D0
\$xx35	RDATA3*	R W	D7	D6	D5	D4	D3	D2	D1	D0
\$xx36	RDATA4*	R W	D7	D6	D5	D4	D3	D2	D1	D0
\$xx37	RDATA5*	R W	D7	D6	D5	D4	D3	D2	D1	D0
\$xx38	RDATA6*	R W	D7	D6	D5	D4	D3	D2	D1	D0
\$xx39	RDATA7*	R W	D7	D6	D5	D4	D3	D2	D1	D0
\$xx3A	RDATA8*	R W	D7	D6	D5	D4	D3	D2	D1	D0
\$xx3B	RDATA9*	R W	D7	D6	D5	D4	D3	D2	D1	D0
\$xx3C	RDATA10*	R W	D7	D6	D5	D4	D3	D2	D1	D0
\$xx3D	RDATA11*	R W	D7	D6	D5	D4	D3	D2	D1	D0
\$xx3E	UNIMPLEMENTED	R W								
\$xx3F	UNIMPLEMENTED	R W								

**Table 43 Active Receive Buffer Registers \$xx30–\$xx3F**

ADDR	REGISTER	R/W	BIT 7	BIT 6	BIT 5	BIT 4	BIT 3	BIT 2	BIT 1	BIT 0
\$xx40	FIDENT*	R W	ID7	ID6	ID5	ID4	ID3	ID2	ID1	ID0
\$xx41	FLEN*	R W	reserved	reserved	reserved	reserved	LEN3	LEN2	LEN1	LEN0
\$xx42	FDATA0*	R W	D7	D6	D5	D4	D3	D2	D1	D0
\$xx43	FDATA1*	R W	D7	D6	D5	D4	D3	D2	D1	D0
\$xx44	FDATA2*	R W	D7	D6	D5	D4	D3	D2	D1	D0
\$xx45	FDATA3*	R W	D7	D6	D5	D4	D3	D2	D1	D0
\$xx46	FDATA4*	R W	D7	D6	D5	D4	D3	D2	D1	D0
\$xx47	FDATA5*	R W	D7	D6	D5	D4	D3	D2	D1	D0
\$xx48	FDATA6*	R W	D7	D6	D5	D4	D3	D2	D1	D0
\$xx49	FDATA7*	R W	D7	D6	D5	D4	D3	D2	D1	D0
\$xx4A	FDATA8*	R W	D7	D6	D5	D4	D3	D2	D1	D0
\$xx4B	FDATA9*	R W	D7	D6	D5	D4	D3	D2	D1	D0
\$xx4C	FDATA10*	R W	D7	D6	D5	D4	D3	D2	D1	D0
\$xx4D	FDATA11*	R W	D7	D6	D5	D4	D3	D2	D1	D0
\$xx4E	UNIMPLEMENTED	R W								
\$xx4F	UNIMPLEMENTED	R W								

Table 44 Active Receive FIFO Buffer Registers \$xx40–\$xx4F

ADDR	REGISTER	R/W	BIT 7	BIT 6	BIT 5	BIT 4	BIT 3	BIT 2	BIT 1	BIT 0
\$xx50	BUFCTL0	R W	IFLG	IENA	LOCK	ABTAK	ABTRQ	0	0	CFG*
\$xx51	BUFCTL1	R W	IFLG	IENA	LOCK	ABTAK	ABTRQ	0	0	CFG*
\$xx52	BUFCTL2	R W	IFLG	IENA	LOCK	ABTAK	ABTRQ	0	0	CFG*
\$xx53	BUFCTL3	R W	IFLG	IENA	LOCK	ABTAK	ABTRQ	0	0	CFG*
\$xx54	BUFCTL4	R W	IFLG	IENA	LOCK	ABTAK	ABTRQ	0	0	CFG*
\$xx55	BUFCTL5	R W	IFLG	IENA	LOCK	ABTAK	ABTRQ	0	0	CFG*
\$xx56	BUFCTL6	R W	IFLG	IENA	LOCK	ABTAK	ABTRQ	0	0	CFG*
\$xx57	BUFCTL7	R W	IFLG	IENA	LOCK	ABTAK	ABTRQ	0	0	CFG*
\$xx58	BUFCTL8	R W	IFLG	IENA	LOCK	ABTAK	ABTRQ	0	0	CFG*
\$xx59	BUFCTL9	R W	IFLG	IENA	LOCK	ABTAK	ABTRQ	0	0	CFG*
\$xx5A	BUFCTL10	R W	IFLG	IENA	LOCK	ABTAK	ABTRQ	0	0	CFG*
\$xx5B	BUFCTL11	R W	IFLG	IENA	LOCK	ABTAK	ABTRQ	0	0	CFG*
\$xx5C	BUFCTL12	R W	IFLG	IENA	LOCK	ABTAK	ABTRQ	0	0	CFG*
\$xx5D	BUFCTL13	R W	IFLG	IENA	LOCK	ABTAK	ABTRQ	0	0	CFG*
\$xx5E	BUFCTL14	R W	IFLG	IENA	LOCK	ABTAK	ABTRQ	0	0	CFG*
\$xx5F	BUFCTL15	R W	IFLG	IENA	LOCK	ABTAK	ABTRQ	0	0	CFG*

**Table 45 Buffer Control Registers \$xx50–\$xx5F**

### Receive and Transmit Message Buffers

There are 16 configurable message buffers, consisting of 14 bytes each. The organization of one message buffer is shown in [Figure 34](#). The first byte contains the 8-bit identifier (ID), the second byte contains the length (LEN) byte (the 4 msb are reserved), followed by a maximum of 12 data bytes (DATA0..11) and two reserved bytes. A LEN value greater than 12 will be transmitted and used in the CRC calculation of transmitter and receiver, but the stored LEN value in the receive buffer will be 12.

The message buffers are configurable as receive, receive FIFO or transmit buffers. The receive and receive FIFO buffer system starts with message buffer 0 and can be configured to the maximum of all 16 message buffers (no transmit buffer). The transmit buffer system starts with message buffer 15 and can be configured to the maximum of all 16 message buffers (no receive buffer).

**NOTE:** *No mixing of receiver, FIFO or transmit buffers is allowed.*

Only the 'active' buffers (transmit buffer, receive buffer and receive FIFO buffer) are addressable by the CPU and allocate 14 bytes each in the memory map. The 'non-active' buffers do not appear in the memory map. To activate a buffer the buffer must be locked. Only one transmit buffer, one receive buffer and one receive FIFO buffer may be locked at a time. A locking error interrupt flag is set and if enabled a locking interrupt is generated when the CPU tries to lock two buffers of the same type.



Addr	Register Name
\$xxx0	Identifier Register
\$xxx1	Data Length Register (4 msb reserved)
\$xxx2	Data Register 0
\$xxx3	Data Register 1
\$xxx4	Data Register 2
\$xxx5	Data Register 3
\$xxx6	Data Register 4
\$xxx7	Data Register 5
\$xxx8	Data Register 6
\$xxx9	Data Register 7
\$xxxA	Data Register 8
\$xxxB	Data Register 9
\$xxxC	Data Register 10
\$xxxD	Data Register 11
\$xxxE	reserved
\$xxxF	reserved

**Figure 34 Message Buffer Organization**

**Message Buffer Control Registers (BUFCTL15..0)**

Each of the 16 configurable message buffers is associated with one Buffer Control Register. All 16 registers are addressable by the CPU. Only a hard reset will clear the register.

	BIT 7	BIT 6	BIT 5	BIT 4	BIT 3	BIT 2	BIT 1	BIT 0
BUFCTLn	R IFLG	IENA	LOCK	ABTAK	ABTRQ	0	0	CFG*
HARDRESET	0	0	0	0	0	0	0	0

**Figure 35 Message Buffer Control Registers (BUFCTL15:BUFCTL0)**

**CFG — Message Buffer Configuration Bit**

This bit is used to configure the corresponding buffer as transmit buffer or as receive or receive FIFO buffer. This bit is readable and is only cleared by hard reset. Writing to this bit is allowed during soft reset only.

- 1 = The corresponding buffer is configured as transmit buffer.
- 0 = The corresponding buffer is configured as receive buffer or receive FIFO buffer.

### ABTRQ — Abort Request

The CPU sets the ABTRQ bit to request that a full transmit buffer (IFLG = 0) is aborted. The request is granted at the next sync pulse if the buffer is still full. The IFLG and the ABTAK flag are set when the message is aborted. The ABTRQ bit is cleared implicitly by setting of the IFLG.

- 1 = Abort request pending.
- 0 = No abort request.

### ABTAK — Abort Acknowledge

This flag acknowledges that a message has been aborted due to a pending abort request from the CPU. The message is aborted at the next sync pulse if the request was pending before the this sync pulse. The application software can use this flag to determine if the message has been sent out or has been aborted. The ABTAK flag is cleared implicitly by clearing the IFLG, i.e. the buffer has been set up again.

- 1 = The message has been aborted.
- 0 = The message has not been aborted, thus has been sent out.

### LOCK — Message Buffer Lock

The bit has various functions depending on the configuration of the corresponding message buffer.

If the buffer is configured as **receive** buffer and the CPU wants to access the buffer it has to lock it first to prevent an overwrite . The locking is done by writing a “1” to the LOCK bit. Only one receive buffer must be locked at a time. The buffer is released by writing a ‘0’ to the lock bit.

If the buffer is configured as **transmit** buffer and the CPU wants to access the buffer it has to lock it first. The locking is done by writing a “1” to the LOCK bit. Only one transmit buffer must be locked at a time. The buffer is released by writing a ‘0’ to the lock bit. The request to lock a full transmit buffer (IFLG = 0) is granted as soon as the buffer has been transmitted.

If there are buffers configured as **receive FIFO** the LOCK bit of buffer 0 is used for locking the FIFO. Writing a ‘1’ locks the FIFO, no verifying is required. The lock controls the GETIDX. The FIFO buffer addressed by the GETIDX is “visible” in the memory map. The

GETIDX is incremented when unlocking the FIFO by writing a '0' to the lock bit of buffer 0. Locking a buffer other than buffer 0 within the FIFO does not influence the FIFO window scheme.

**NOTE:** *The lock request is stored, i.e. only one write is necessary. Internal synchronization takes up to two CPU cycle to update the LOCK bit, i.e. the application software should access a locked buffer after verifying the lock bit*

#### IENA — Interrupt Enable Bit

This bit enables the corresponding buffer as interrupt source.

1 = The corresponding buffer interrupt enabled.

0 = The corresponding buffer interrupt disabled.

#### IFLG — Interrupt Status Flag

This flag has various functions depending on the configuration of the corresponding message buffer.

If the buffer is configured as **receive** buffer this flag indicates that the buffer is full. The status flag is cleared if a '1' is written to the bit position. The soft reset value is '0'.

1 = Flag set when the receive buffer is full.

0 = Flag cleared when the receive buffer is empty.

If the buffer is configured as **transmit** buffer this flag indicates that the buffer is empty. The status flag is cleared if a '1' is written to the bit position. The soft reset value is '1'.

1 = Flag set when the transmit buffer is empty (i.e. has been transmitted or has been aborted).

0 = Flag cleared when the transmit buffer is full and ready for transmit.

If the buffer is configured as **receive FIFO** buffer this flag has no meaning. It will never be set. The soft reset value is '0'.

Module  
Configuration  
Register (MCR)

		BIT 7	BIT 6	BIT 5	BIT 4	BIT 3	BIT 2	BIT 1	BIT 0
MCR \$xx00	R	SFTRES	MASTER*	ALARM	SLPAK	SLPRQ	WPULSE*	SSWAI	0
	W								
HARDRESET		1	0	0	0	0	0	0	0

Figure 36 General Configuration Register (MCR)

**NOTE:** Setting SFTRES and writing to other bits in the MCR can be done in separate instructions only! Trying to set SFTRES and change other bits together will change the SFTRES only, the other bits will be unchanged. Clearing SFTRES and writing to other bits in the MCR can be done in one instruction.

SFTRES — Soft Reset

When this bit is set by the CPU, the module immediately enters the soft reset state. Any ongoing transmission or reception is aborted and synchronization to the bus is lost.

When this bit is cleared by the CPU, the interface will start to connect back to the bus. It will be synchronized after the next SYNC pulse on the bus.

- 1 = Soft reset state.
- 0 = Normal operation.

MASTER — Master Select

This bit selects the node as bus master or as bus slave. Writing to this bit is allowed during soft reset only.

- 1 = The interface is a master and generates the SYNC pulses.
- 0 = The interface is a slave and verifies the SYNC pulses.

ALARM — Master Alarm Pulses

If the Master bit and the Alarm bit are set, ALARM pulses are transmitted.

- 1 = The interface generates ALARM pulses.
- 0 = The interface generates normal SYNC pulses.

The ALARM bit is reset after 255ms - 256ms if it has not been set again by the CPU within that period. The Alarm bit can be set and cleared any time.

**SLPACK — Sleep Acknowledge**

This read-only bit indicates that the interface has reached the sleep mode state. This allows an accurate shut off of the module before the shut off of the remaining system.

- 1 = Module is in sleep mode.
- 0 = Module is in normal run mode.

**SLPRQ — Sleep request, enter Low Power Module Sleep Mode**

This bit requests the module to enter sleep mode, the clock will be stopped. This allows the module to be shut off when not in use. The CPU can still access the Module Configuration Register. If SLPRQ is asserted in the middle of transmission or reception of a message or is asserted while the temporary message buffers are full, the clock will be stopped at the end of this message, respectively when the temporarily buffers are empty. It remains stopped until a wakeup occurs.

- 1 = Enter Low Power Sleep Mode.
- 0 = Normal Mode.

**WPULSE — Wakeup Pulses**

This bit causes to transmit wakeup pulses with the pulse width of  $t_{wake\_up}$ . The wakeup sequence is used to wakeup the transceiver from sleep mode. Writing to this bit is allowed during soft reset only.

- 1 = The interface generates wakeup pulses.
- 0 = The interface does not generate wakeup pulses.

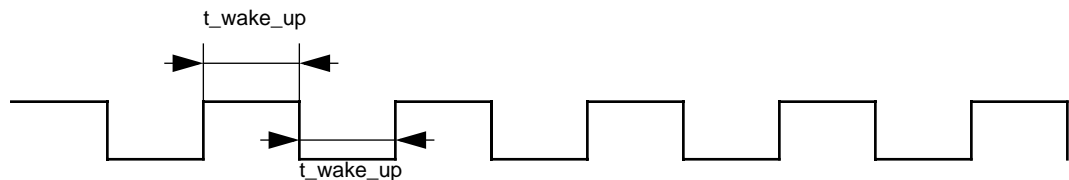

**Figure 37 Wakeup Pulses**

**SSWAI — Serial Bus Interface Stops in Wait Mode**

- 1 = The module ceases to be clocked during WAIT mode.
- 0 = The module is not affected during WAIT mode.

FIFO Size Register (FSIZR)

		BIT 7	BIT 6	BIT 5	BIT 4	BIT 3	BIT 2	BIT 1	BIT 0
FSIZR	R	0	0	0	FSIZ4*	FSIZ3*	FSIZ2*	FSIZ1*	FSIZ0*
\$xx01	W								
RESET		0	0	0	0	0	0	0	0

Figure 38 FIFO Size Register (FSIZR)

FSIZ4:0 — FIFO Size Bits

These bits are used to configure the FIFO. The number of buffers, starting from buffer '0', assigned to the receive FIFO can be selected. The corresponding buffer(s) must be assigned as Receive buffer by the CFG-bits in the message buffer control register(s).

Table 46 FIFO Size

FSIZ[4:0]	FIFO Size
0 0000	No FIFO
0 0001	buffer 0
0 0010	buffers 0, 1
0 0011	buffers 0- 2
:	:
01111	buffers 0-14
10000	buffers 0-15
	buffers 0-15
11111	buffers 0-15

**NOTE:** The FSIZR register can only be written if the SFTRES bit in the Module Configuration register is set.

**Time Configuration Register 1 (TCR1)** The time configuration register 1 contains the specific programmable time  $t_{wx0\_tx}$  for the node. Only a hard reset will clear the register.

		BIT 7	BIT 6	BIT 5	BIT 4	BIT 3	BIT 2	BIT 1	BIT 0
TCR1	R	TWX0T7*	TWX0T6*	TWX0T5*	TWX0T4*	TWX0T3*	TWX0T2*	TWX0T1*	TWX0T0*
\$xx02	W								
HARDRESET		0	0	0	0	0	0	0	0

**Figure 39 Time Configuration Register 1 (TCR1)**

TWX0T7:TWX0T0 — Time  $t_{wx0\_tx}$

These bits select the Offset Time  $t_{wx0\_tx}$  as shown in [Table 47](#).

**Table 47 Time  $t_{wx0\_tx}$**

TWX0T[7:0]	$t_{wx0\_tx}[\text{ns}]/25 - 7$
------------	---------------------------------

**NOTE:** The TCR1 register can only be written if the SFTRES bit in the Module Configuration register is set.

**Time Configuration Register 2 (TCR2)** The time configuration register 2 contains the specific programmable time  $t_{wx0\_rx}$  for the node. Only a hard reset will clear the register.

		BIT 7	BIT 6	BIT 5	BIT 4	BIT 3	BIT 2	BIT 1	BIT 0
TCR2	R	TWX0R7*	TWX0R6*	TWX0R5*	TWX0R4*	TWX0R3*	TWX0R2*	TWX0R1*	TWX0R0*
\$xx03	W								
HARDRESET		0	0	0	0	0	0	0	0

**Figure 40 Time Configuration Register 2 (TCR2)**

TWX0R7:TWX0R0 — Time  $t_{wx0\_rx}$

These bits select the Offset Time  $t_{wx0\_rx}$  as shown in [Table 48](#).

**Table 48 Time  $t_{wx0\_rx}$**

TWX0R[7:0]	$t_{wx0\_rx}[\text{ns}]/25 - 7$
------------	---------------------------------

**NOTE:** The TCR2 register can only be written if the SFTRES bit in the Module Configuration register is set.

**TIME CONFIGURATION REGISTER 3 (TCR3)**

The time configuration register 3 contains the specific programmable time  $t_{wx\_delta}$  for the node. Only a hard reset will clear the register.

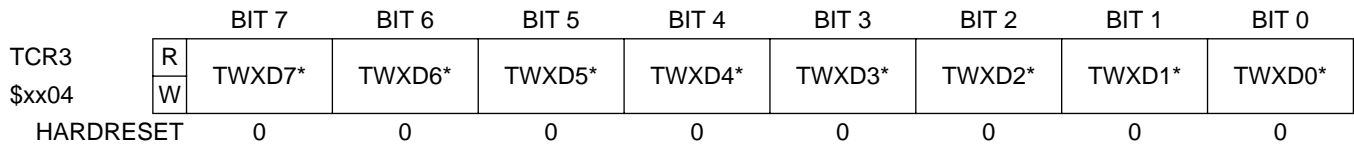

**Figure 41 Time Configuration Register 3 (TCR3)**

TWXD7:TWXD0 — Time  $t_{wx\_delta}$

These bits contain the value for the time  $t_{wx\_delta}$  as shown in [Table 49](#).

**Table 49 Time  $t_{wx\_delta}$  calculation**

TWXD[7:0]	$t_{wx\_delta}[ns]/25 - 1$
-----------	----------------------------

**NOTE:** The TCR3 register can only be written if the SFTRES bit in the Module Configuration register is set. The lower bound for TCR3 is 3.

**Receive Interrupt Status Register (RISR)**

The Receive Interrupt Status Register indicates the occurrence of receive or SYNC pulse events, and together with the Receive Interrupt Enable Register allows the module to operate in a polled or interrupt driven system. Different interrupts can be generated. The Optical Diagnosis Flag (OPTDF) is an indicator for the quality of the optical line between two nodes. The OPTDF flag uses the internal error bit of the optical transceiver which is driven on the Rx line when the photo stream is below a certain level (see ELMOS E100.34 S/E module).

SYNAIF, SYNNIF, SLMMIF, XSYNIF and OPTDF are read and clear only. RCVFIF and RXIF are read only. A flag can be cleared by writing a 1 to the corresponding bit position. Only one write is necessary to request the clearing, i.e. the clear request is stored and executed as soon as the condition which caused the setting is no longer valid. Writing a 0 has no effect on the flag setting. Every flag has an associated interrupt enable flag in the Receive Interrupt Enable Register. A hard or soft reset will clear the register.



	BIT 7	BIT 6	BIT 5	BIT 4	BIT 3	BIT 2	BIT 1	BIT 0	
RISR	R	RCVFIF	RXIF	SYNAIF	SYNNIF	SLMMIF	0	XSYNIF	OPTDF
\$xx06	W								
H/S-RESET	0	0	0	0	0	0	0	0	

**Figure 42 Receive Interrupt Status Register (RISR)**

**RCVFIF — Receive FIFO Not Empty Interrupt Flag**

This read-only bit will be set when the Receive FIFO is not empty. If enabled, a FIFO not empty interrupt is pending while this flag is set. The flag will be cleared if the FIFO is empty and when buffer 0 is unlocked. The flag remains set if the FIFO is not empty.

- 1 = Receive FIFO is not empty.
- 0 = Receive FIFO is empty.

**NOTE:** *The RCVFIF flag is cleared two CPU cycles after unlocking buffer 0 if the FIFO is empty, i.e. the application software should not read the RCVFIF flag immediately after unlocking buffer 0.*

**RXIF — Receive Interrupt Flag**

This read-only bit will be set when any of the enabled (IENAn = 1) receive buffers has successfully received a message. It can be cleared by clearing of the IFLG bit(s) of the corresponding buffer(s). If RXIE is set, a receive interrupt is pending while this flag is set.

- 1 = At least one receive buffer is full.
- 0 = All receive buffers are empty.

**NOTE:** *The RXIF flag is cleared two CPU cycles after clearing of all IFLG bits, i.e. the application software should not read the RXIF flag immediately after clearing the IFLG bit(s).*

**SYNAIF — Synchronization Pulse ALARM Interrupt Flag**

This bit will be set when a SYNC pulse ALARM has been received. If enabled, a SYNC pulse interrupt is pending while this flag is set.

- 1 = SYNC pulse ALARM has been received.
- 0 = No SYNC pulse ALARM has occurred.

**SYNNIF — Synchronization Pulse NORMAL Interrupt Flag**

This bit will be set when a SYNC pulse NORMAL has been received. If enabled, a SYNC pulse interrupt is pending while this flag is set.

1 = SYNC pulse NORMAL has been received.

0 = No SYNC pulse NORMAL has occurred.

**SLMMIF — Slot Mismatch Interrupt Flag**

This bit will be set when the identifier of a successfully received message differs from the current time slot.

1 = A mismatch between successfully received identifier and slot counter has occurred.

0 = No slot mismatch has occurred.

**XSYNIF — XSYNC Pulse Interrupt Flag**

This bit will be set when a valid SYNC pulse (NORMAL or ALARM Sync pulse) has been received. If enabled, an XSYNC pulse interrupt is pending while the flag is set.

1 = SYNC pulse has been received.

0 = No SYNC pulse has occurred.

**OPTDF — Optical Diagnosis Flag**

This bit will be set when the internal error bit of the optical transceiver is driven on the Rx line during transmission.

1 = A pulse on Rx has been detected.

0 = No pulse on Rx has been detected.

**General Interrupt Status Register (GISR)**

The General Interrupt Status Register indicates the occurrence of system events, and together with the General Interrupt Enable Register allows the module to operate in a polled or interrupt driven system. A general interrupt can be generated.

OVRNIF, ERRIF, SYNEIF, SYNLIF, ILLPIF and WAKEIF are read and clear only. TXIF and LOCKIF are read only. A flag can be cleared by writing a 1 to the corresponding bit position. Only one write is necessary to request the clearing, i.e. the clear request is stored and executed as soon as the condition which caused the setting is no longer valid.

SYNLIF can only be cleared after receiving a valid sync pulse. Writing a 0 has no effect on the flag setting. Every flag has an associated interrupt enable bit in the General Interrupt Enable Register. A hard or soft reset will clear the register (except LOCKIF, which can only be cleared by a hard or system reset).

		BIT 7	BIT 6	BIT 5	BIT 4	BIT 3	BIT 2	BIT 1	BIT 0
GISR \$xx07	R	TXIF	OVRNIF	ERRIF	SYNEIF	SYNLIF	ILLPIF	LOCKIF	WAKEIF
	W								
H/S-RESET		0	0	0	0	0	0	0	0

**Figure 43 General Interrupt Status Register (GISR)**

**TXIF — Transmit Interrupt Flag**

This read-only bit will be set when any of the enabled (IENAn = 1) transmit buffers is empty. It can be cleared by clearing the IFLG bit(s) of the corresponding buffer(s). After soft reset the flag is set if there is at least one transmit buffer configured. If TXIE is set, a general interrupt is pending while this flag is set.

- 1 = At least one transmit buffer is empty.
- 0 = All transmit buffers are full.

**NOTE:** *The TXIF flag is cleared two CPU cycles after clearing of all IFLG bits, i.e. the application software should not read the TXIF flag immediately after clearing the IFLG bit(s).*

**OVRNIF — Receive FIFO Overrun Interrupt Flag**

This bit will be set when a Receive FIFO overrun occurred. If enabled, a general interrupt is pending while this flag is set.

- 1 = A Receive FIFO overrun has been detected.
- 0 = No Receive FIFO overrun has occurred.

**ERRIF — Message Format Error (CRC, Frame) Interrupt Flag**

This bit will be set when a Message Format Error (CRC Error, Frame Error) occurred. If enabled, a general interrupt is pending while this flag is set.

- 1 = A Message Format Error has been detected.
- 0 = No Message Format Error has occurred.

**SYNEIF — SYNC Pulse Too Early Error Interrupt Flag**

This bit will be set when a SYNC pulse too early error appears. If enabled, a general interrupt is pending while this flag is set.

- 1 = SYNC pulse to early error.
- 0 = No SYNC pulse to early error has occurred.

**SYNLIF — SYNC Pulse Lost Error Interrupt Flag**

This bit will be set when a SYNC pulse lost error appears. If enabled, a general interrupt is pending while this flag is set. The flag is enabled as soon as the first valid normal/alarm synchronization pulse has been detected.

1 = SYNC pulse lost error.

0 = No SYNC pulse lost error has occurred.

**ILLPIF — Illegal Pulse Error Interrupt Flag**

This bit will be set when an illegal pulse error appears. If enabled, a general interrupt is pending while this flag is set.

1 = Illegal pulse error.

0 = No illegal pulse error has occurred.

**LOCKIF — Locking Error Interrupt Flag**

This bit will be set when two Rx buffers or two Tx buffers are locked at the same time. If enabled, a general interrupt is pending while this flag is set and the module enters soft reset. The bit is only cleared by a hard or system reset.

1 = Locking error.

0 = No locking error has occurred.

**WAKEIF — WAKEUP Interrupt Flag**

This bit will be set when the module detects bus activity whilst it is asleep. If enabled, a general interrupt is pending while this flag is set.

1 = Detected activity on the bus.

0 = No wake-up activity has been observed while in sleep mode.

**Receive Interrupt Enable Register (RIER)**

The Receive Interrupt Enable Register allows to enable/disable the different receive or SYNC pulse interrupt sources for different interrupt requests. A hard or soft reset will clear the register.

		BIT 7	BIT 6	BIT 5	BIT 4	BIT 3	BIT 2	BIT 1	BIT 0
RIER \$xx08	R	RCVFIE	RXIE	SYNAIE	SYNNIE	SLMMIE	0	XSYNIE	0
	W								
H/S-RESET		0	0	0	0	0	0	0	0

**Figure 44 Receive Interrupt Enable Register (RIER)**

**RCVFIE** — Receive FIFO Not Empty Interrupt Enable

1 = A Receive FIFO not empty event will result in a receive FIFO not empty interrupt.

0 = No interrupt will be generated from this event.

**RXIE** — Receive Interrupt Enable

1 = A receive event will result in a receive interrupt.

0 = No interrupt will be generated from this event.

**SYNAIE** — Synchronization Pulse ALARM Interrupt Enable

1 = A SYNC pulse ALARM event will result in a SYNC pulse interrupt.

0 = No interrupt will be generated from this event.

**SYNNIE** — Synchronization Pulse NORMAL Interrupt Enable

1 = A SYNC pulse NORMAL event will result in a SYNC pulse interrupt.

0 = No interrupt will be generated from this event.

**SLMMIE** — Slot Mismatch Interrupt Enable

1 = A slot mismatch event will result in a general interrupt.

0 = No interrupt will be generated from this event.

**XSYNIE** — Xsync Pulse Interrupt Enable

1 = A SYNC pulse event will result in an XSYNC pulse interrupt.

0 = No interrupt will be generated from this event.

**General Interrupt Enable Register (GIER)**

The General Interrupt Enable Register allows to enable/disable the different interrupt sources for the general interrupt request. A hard or soft reset will clear the register.

		BIT 7	BIT 6	BIT 5	BIT 4	BIT 3	BIT 2	BIT 1	BIT 0
GIER \$xx09	R	TXIE	OVRNIE	ERRIE	SYNEIE	SYNLIE	ILLPIE	LOCKIE*	WAKEIE
	W								
H/S-RESET		0	0	0	0	0	0	0	0

**Figure 45 General Interrupt Enable Register (GIER)**

**TXIE** — Transmit Interrupt Enable

- 1 = A transmit event will result in a general interrupt.
- 0 = No interrupt will be generated from this event.

**OVRNIE** — Receive FIFO Overrun Interrupt Enable

- 1 = A Receive FIFO overrun event will result in a general interrupt.
- 0 = No interrupt will be generated from this event.

**ERRIE** — Message Format Error (CRC or Frame) Interrupt Enable

- 1 = A Message Format Error will result in a general interrupt.
- 0 = No interrupt will be generated from this event.

**SYNEIE** — SYNC Pulse Too Early Error Interrupt Enable

- 1 = A SYNC pulse too early error will result in a general interrupt.
- 0 = No interrupt will be generated from this event.

**SYNLIE** — SYNC Pulse Lost Error Interrupt Enable

- 1 = A SYNC pulse lost error will result in a general interrupt.
- 0 = No interrupt will be generated from this event.

**ILLPIE** — Illegal Pulse Error Interrupt Enable

- 1 = An illegal pulse error will result in a general interrupt.
- 0 = No interrupt will be generated from this event.

**LOCKIE** — Locking Error Interrupt Enable

1 = A locking error will result in a general interrupt and the module will enter soft reset.

0 = No interrupt will be generated from this event and the module does not enter soft reset.

**NOTE:** *The LOCKIE bit can only be written if the SFTRES bit in the Module Configuration register is set.*

**WAKEIE** — WAKEUP Interrupt Enable

1 = A requested wake-up will result in a general interrupt.

0 = No interrupt will be generated from this event.

**Receive Interrupt Vector Register (RIVEC)**

The read-only Receive Interrupt Vector Register shows the lowest numbered message buffer that has its interrupt status flag (IFLG) and its interrupt enable bit (IENA) set. A hard or soft reset will clear the register.

		BIT 7	BIT 6	BIT 5	BIT 4	BIT 3	BIT 2	BIT 1	BIT 0
RIVEC	R	0	0	0	0	RIVEC3	RIVEC2	RIVEC1	RIVEC0
\$xx0A	W								
H/S-RESET		0	0	0	0	0	0	0	0

**Figure 46 Receive Interrupt Source Register (RIVEC)**

**NOTE:** *The Receive Interrupt Vector Register contains only valid data if RXIF is set.*

**Transmit Interrupt Vector Register (TIVEC)**

The read-only Transmit Interrupt Vector Register shows the highest numbered message buffer that has its interrupt status flag (IFLG) and its interrupt enable bit (IENA) set. A hard or soft reset will clear the register.

		BIT 7	BIT 6	BIT 5	BIT 4	BIT 3	BIT 2	BIT 1	BIT 0
TIVEC	R	0	0	0	0	TIVEC3	TIVEC2	TIVEC1	TIVEC0
\$xx0B	W								
H/S-RESET		0	0	0	0	1	1	1	1

**Figure 47 Transmit Interrupt Source Register (TIVEC)**

**NOTE:** *The Transmit Interrupt Vector Register contains only valid data if TXIF is set.*

Byteflight™ Module

FIFO Identifier Acceptance Register(FIDAC)

The FIFO identifier acceptance register defines a user specified sequence of bits with which the incoming identifier is compared. This determines whether the message is accepted by the FIFO. Only a hard reset will clear the register.

		BIT 7	BIT 6	BIT 5	BIT 4	BIT 3	BIT 2	BIT 1	BIT 0
FIDAC \$xx0C	R	FIDAC7*	FIDAC6*	FIDAC5*	FIDAC4*	FIDAC3*	FIDAC2*	FIDAC1*	FIDAC0*
	W								
HARDRESET		0	0	0	0	0	0	0	0

Figure 48 FIFO Identifier Acceptance Register

**NOTE:** The FIDAC register can only be written if the SFTRES bit in the Module Configuration register is set.

FIFO Identifier Mask Register (FIDMR)

The identifier mask register specifies which of the corresponding bits in the identifier acceptance register are relevant for acceptance filtering. A cleared bit in this register indicates that the corresponding bit in the identifier acceptance register must be the same as the incoming identifier bit, before a match will be detected. The message will be accepted by the FIFO if all such bits match. If a bit is set, it indicates that the state of the corresponding bit in the identifier acceptance register will not affect whether or not the message is accepted by the FIFO. Only a hard reset will clear the register.

Bit description:

- 1 = Ignore corresponding acceptance register bit
- 0 = Match corresponding acceptance register bit

		BIT 7	BIT 6	BIT 5	BIT 4	BIT 3	BIT 2	BIT 1	BIT 0
FIDMR \$xx0D	R	FIDMR7*	FIDMR6*	FIDMR5*	FIDMR4*	FIDMR3*	FIDMR2*	FIDMR1*	FIDMR0*
	W								
HARDRESET		0	0	0	0	0	0	0	0

Figure 49 FIFO Identifier Mask Register

**NOTE:** The FIDMR register can only be written if the SFTRES bit in the Module Configuration register is set.



**FIFO Identifier  
Rejection Register  
(FIDRJ)**

The FIFO identifier rejection register defines a user specified sequence of bits with which the incoming identifier is compared. This determines whether the message is rejected by the FIFO. Only a hard reset will clear the register.

		BIT 7	BIT 6	BIT 5	BIT 4	BIT 3	BIT 2	BIT 1	BIT 0
FIDRJ \$xx14	R	FIDRJ7*	FIDRJ6*	FIDRJ5*	FIDRJ4*	FIDRJ3*	FIDRJ2*	FIDRJ1*	FIDRJ0*
	W								
HARDRESET		0	0	0	0	0	0	0	0

**Figure 50 FIFO Identifier Rejection Register**

**NOTE:** The FIDRJ register can only be written if the SFTRES bit in the Module Configuration register is set.

**FIFO Identifier  
Rejection Mask  
Register (FIDRMR)**

The identifier rejection mask register specifies which of the corresponding bits in the identifier rejection register are relevant for rejection filtering. A cleared bit in this register indicates that the corresponding bit in the identifier rejection register must be the same as the incoming identifier bit, before a match will be detected. The message will be rejected by the FIFO if all such bits match. If a bit is set, it indicates that the state of the corresponding bit in the identifier rejection register will not affect whether or not the message is rejected by the FIFO. Only a hard reset will set the register.

Bit description:

- 1 = Ignore corresponding rejection register bit
- 0 = Match corresponding rejection register bit

		BIT 7	BIT 6	BIT 5	BIT 4	BIT 3	BIT 2	BIT 1	BIT 0
FIDRMR \$xx15	R	FIDRMR7*	FIDRMR6*	FIDRMR5*	FIDRMR4*	FIDRMR3*	FIDRMR2*	FIDRMR1*	FIDRMR0*
	W								
HARDRESET		1	1	1	1	1	1	1	1

**Table 50 FIFO Rejection Mask Register**

**NOTE:** The FIDRMR register can only be written if the SFTRES bit in the Module Configuration register is set.

Byteflight™ Module

**Module Version Register (MVR)** The read-only Module Version Register contains the version number of the implementation.

		BIT 7	BIT 6	BIT 5	BIT 4	BIT 3	BIT 2	BIT 1	BIT 0
MVR	R	MVR7	MVR6	MVR5	MVR4	MVR3	MVR2	MVR1	MVR0
\$xx0E	W								

**Figure 51 Module Version Register (MVR)**

**Byteflight™ Port SBI Control Register (PCTLSBI)**

		BIT 7	BIT 6	BIT 5	BIT 4	BIT 3	BIT 2	BIT 1	BIT 0
PCTLSBI	R	PMEREN	0	PSLMEN	PERREN	PROKEN	PSYNNEN	PUESBI	RDRSBI
\$xx10	W								
HARDRESET		0	0	0	0	0	0	0	0

**Figure 52 Port SBI Control Register (PCTLSBI)**

The following bits control pins of Port SBI. Pins 1 and 0 are reserved for the Rx (input only) and Tx (output only) pins. Only a hard reset will clear the register.

**PMEREN** — Slot Mismatch Error Enable

- 1 = A 50ns pulse is driven on Port SBI4 after a slot mismatch.
- 0 = Port SBI4 is a general IO pin.

**PSLMEN** — Slot Mismatch Enable

- 1 = A 50ns pulse is driven on Port SBI5 after a slot mismatch.
- 0 = Port SBI5 is a general IO pin.

**PERREN** — Error Pulse Enable

- 1 = A 50ns pulse is driven on Port SBI4 after a message format or illegal pulse error.
- 0 = Port SBI4 is a general IO pin.

**PROKEN** — Reception OK Pulse Enable

- 1 = A 50ns pulse is driven on Port SBI3 after the successful reception of a message or sync pulse.
- 0 = Port SBI3 is a general IO pin.

PSYNEN — Sync Pulse Enable

- 1 = A 50ns pulse is driven on Port SBI2 after the successful reception or transmission of a sync pulse.
- 0 = Port SBI2 is a general IO pin.

PUESBI — Pull Up Enable Port SBI

- 1 = Pull up enabled for Port SBI.
- 0 = Pull up disabled for Port SBI.

RDRSBI — Reduced Drive Port SBI

- 1 = Reduced drive enabled for Port SBI.
- 0 = Reduced drive disabled for Port SBI.

Byteflight™ Port  
SBI Data Register  
(PORTSBI

		BIT 7	BIT 6	BIT 5	BIT 4	BIT 3	BIT 2	BIT 1	BIT 0
PORTSBI \$xx11	R	PSBI7	PSBI6	PSBI5	PSBI4	PSBI3	PSBI2	TX	RX
	W								
HARDRESET		U	U	U	U	U	U	U	U

Figure 53 Port SBI Data Register (PORTSBI)

PSBI7 – PSBI2 — Port SBI Data Bits

Writing to PSBIx stores the bit value in an internal bit memory. This value is driven to the respective pin only if DDRSBIx = 1. Only a hard reset will clear the register.

Reading PSBIx returns

- the value of the internal bit memory driven to the pin, if DDRSBIx = 1
- the value of the respective pin, if DDRSBIx = 0

Reading bits 1 and 0 returns the value of the Tx and Rx pins, respectively.

Byteflight™ Module

Byteflight™ Port  
SBI Data Direction  
Register (DDRSBI)

		BIT 7	BIT 6	BIT 5	BIT 4	BIT 3	BIT 2	BIT 1	BIT 0
DDRSBI \$xx12	R	DDRSBI7	DDRSBI6	DDRSBI5	DDRSBI4	DDRSBI3	DDRSBI2	0	0
	W								
HARDRESET		0	0	0	0	0	0	0	0

Figure 54 Port SBI Data Direction Register (DDRSBI)

DDRSBI7 – DDRSBI2 — Data Direction Port SBI Bits

1 = Respective I/O pin is configured for output.

0 = Respective I/O pin is configured for input.

The Port SBI5–2 pins are outputs, if PMEREN, PSLMEN, PERREN, PROKEN and PSYNEN are set, regardless of their corresponding Data Direction Bits. Only a hard reset will clear the register.

---



---

## Initialization

To ensure correct operation, use the following initialization procedure:

- Enter the soft reset mode by setting the SFTRES bit (MCR)
- Desired setting of module configuration register (MCR) – Master or Slave select, MASTER bit
- Desired setting of the FIFO Size register (FSIZR) – configure FIFO size, FSIZ4:0 bits
- Desired setting of time configuration registers (TCR1–TCR3)
- Desired setting of the message buffer control registers (BUFCTL15..0) – configure the buffers as transmit or receive buffers
  - enable/disable of the corresponding interrupt, IENA bits
- Set FIFO acceptance register (FIDAC) and mask register (FIDMR).
- Exit the soft reset mode by resetting the SFTRES bit (MCR)

---

---

## FIFO Usage

The user's receive FIFO handler has to run the following procedure assuming the FIFO is not empty:

- lock the FIFO buffer by setting the LOCK bit of buffer 0, the buffer with the oldest unaccessed message, addressed by GETIDX, appears in the memory map
- copy over the message
- unlock the FIFO buffer, the GETIDX will be incremented

Unlocking an empty FIFO does not increment the GETIDX and does not set the FIFO empty flag.



# Analog to Digital Converter

---

---

## Contents

Introduction . . . . .	219
Functional Description. . . . .	220
ATD Registers. . . . .	221
ATD Mode Operation . . . . .	230

---

---

## Introduction

The ATD is an 8-channel, 10-bit, multiplexed-input successive-approximation analog-to-digital converter, accurate to  $\pm 2$  least significant bits (LSB). It does not require external sample and hold circuits because of the type of charge redistribution technique used. The ATD converter timing is synchronized to the system P clock. The ATD module consists of a 16-word (32-byte) memory-mapped control register block used for control, testing and configuration.

Analog to Digital Converter

Freescale Semiconductor, Inc.

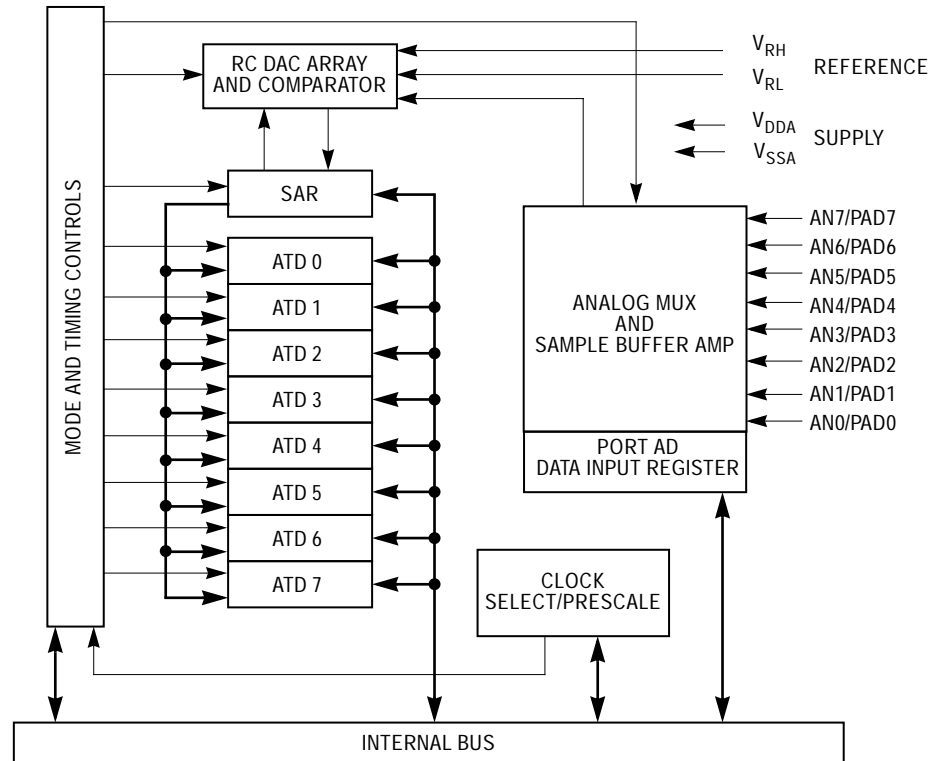

Figure 55 Analog-to-Digital Converter Block Diagram

Functional Description

A single conversion sequence consists of four or eight conversions, depending on the state of the select 8 channel mode (S8CM) bit when ATDCTL5 is written. There are eight basic conversion modes. In the non-scan modes, the SCF bit is set after the sequence of four or eight conversions has been performed and the ATD module halts. In the scan modes, the SCF bit is set after the first sequence of four or eight conversions has been performed, and the ATD module continues to restart the sequence. In both modes, the CCF bit associated with each register is set when that register is loaded with the appropriate conversion result. That flag is cleared automatically when that result register is read. The conversions are started by writing to the control registers.



---



---

## ATD Registers

### ATDCTL0 — Reserved

**\$0060**

	Bit 7	6	5	4	3	2	1	Bit 0
	0	0	0	0	0	0	0	0
RESET:	0	0	0	0	0	0	0	0

Write to this register will abort current conversion sequence. READ: any time, WRITE: any time.

### ATDCTL1 — Reserved

**\$0061**

	Bit 7	6	5	4	3	2	1	Bit 0
	0	0	0	0	0	0	0	0
RESET:	0	0	0	0	0	0	0	0

WRITE: write to this register has no meaning. READ: Special Mode only.

### ATDCTL2 — ATD Control Register 2

**\$0062**

	Bit 7	6	5	4	3	2	1	Bit 0
	ADPU	AFFC	AWAI	0	0	0	ASCIE	ASCIF
RESET:	0	0	0	0	0	0	0	0

The ATD control register 2 and 3 are used to select the power up mode, interrupt control, and freeze control. Writes to these registers abort any current conversion sequence.

Read or write anytime except ASCIF bit, which cannot be written.

Bit positions ATDCTL2[4:2] and ATDCTL3[7:2] are unused and always read as zeros.

#### ADPU — ATD Disable

0 = Disables the ATD, including the analog section for reduction in power consumption.

1 = Allows the ATD to function normally.

Software can disable the clock signal to the ATD converter and power down the analog circuits to reduce power consumption. When reset to zero, the ADPU bit aborts any conversion sequence in progress.

Because the bias currents to the analog circuits are turned off, the ATD requires a period of recovery time to stabilize the analog circuits after setting the ADPU bit.

**AFFC — ATD Fast Flag Clear All**

- 0 = ATD flag clearing operates normally (read the status register before reading the result register to clear the associate CCF bit).
- 1 = Changes all ATD conversion complete flags to a fast clear sequence. Any access to a result register (ATD0–7) will cause the associated CCF flag to clear automatically if it was set at the time.

**AWAI — ATD Stop in Wait Mode**

- 0 = ATD continues to run when the MCU is in wait mode
- 1 = ATD stops to save power when the MCU is in wait mode

**ASCIE — ATD Sequence Complete Interrupt Enable**

- 0 = Disables ATD interrupt
- 1 = Enables ATD interrupt on sequence complete

**ASCIF — ATD Sequence Complete Interrupt**

- Cannot be written in any mode.
- 0 = No ATD interrupt occurred
- 1 = ATD sequence complete

**ATDCTL3 — ATD Control Register 3**

**\$0063**

	Bit 7	6	5	4	3	2	1	Bit 0
	0	0	0	0	0	0	FRZ1	FRZ0
RESET:	0	0	0	0	0	0	0	0

**FRZ1, FRZ0 — Background Debug (Freeze) Enable (suspend module operation at breakpoint)**

When debugging an application, it is useful in many cases to have the ATD pause when a breakpoint is encountered. These two bits determine how the ATD will respond when background debug mode becomes active.

**Table 51 ATD Response to Background Debug Enable**

FRZ1	FRZ0	ATD Response
0	0	Continue conversions in active background mode
0	1	Reserved
1	0	Finish current conversion, then freeze
1	1	Freeze when BDM is active

**ATDCTL4 — ATD Control Register 4**

**\$0064**

	Bit 7	6	5	4	3	2	1	Bit 0
	S10BM	SMP1	SMP0	PRS4	PRS3	PRS2	PRS1	PRS0
RESET:	0	0	0	0	0	0	0	1

The ATD control register 4 is used to select the clock source and set up the prescaler. Writes to the ATD control registers initiate a new conversion sequence. If a write occurs while a conversion is in progress, the conversion is aborted and ATD activity halts until a write to ATDCTL5 occurs.

**S10BM — ATD 10-bit Mode Control**

- 0 = 8 bit operation
- 1 = 10 bit operation

**SMP1, SMP0 — Select Sample Time**

These bits are used to select one of four sample times after the buffered sample and transfer has occurred.

**Table 52 Final Sample Time Selection**

SMP1	SMP0	Final Sample Time	Total 8-Bit Conversion Time	Total 10-Bit Conversion Time
0	0	2 ATD clock periods	18 ATD clock periods	20 ATD clock periods
0	1	4 ATD clock periods	20 ATD clock periods	22 ATD clock periods
1	0	8 ATD clock periods	24 ATD clock periods	26 ATD clock periods
1	1	16 ATD clock periods	32 ATD clock periods	34 ATD clock periods

**PRS4, PRS3, PRS2, PRS1, PRS0 — Select Divide-By Factor for ATD P-Clock Prescaler.**

The binary value written to these bits (1 to 31) selects the divide-by factor for the modulo counter-based prescaler. The P clock is divided by this value plus one and then fed into a ÷2 circuit to generate the

ATD module clock. The divide-by-two circuit insures symmetry of the output clock signal. Clearing these bits causes the prescale value default to one which results in a ÷2 prescale factor. This signal is then fed into the ÷2 logic. The reset state divides the P clock by a total of four and is appropriate for nominal operation between 2 MHz and 8 MHz bus rate. For operation at 10 MHz this value must be reprogrammed first to ÷6 or greater before using the ATD. Table 53 shows the divide-by operation and the appropriate range of system clock frequencies.

**Table 53 Clock Prescaler Values**

Prescale Value	Total Divisor	Max P Clock <sup>(1)</sup>	Min P Clock <sup>(2)</sup>
00000	÷2	4 MHz	1 MHz
00001	÷4	8 MHz	2 MHz
00010	÷6	10 MHz	3 MHz
00011	÷8	10 MHz	4 MHz
00100	÷10	10 MHz	5 MHz
00101	÷12	10 MHz	6 MHz
00110	÷14	10 MHz	7 MHz
00111	÷16	10 MHz	8 MHz
01xxx	Do Not Use		
1xxxx			

1. Maximum conversion frequency is 2 MHz. Maximum P clock divisor value will become maximum conversion rate that can be used on this ATD module.
2. Minimum conversion frequency is 500 KHz. Minimum P clock divisor value will become minimum conversion rate that this ATD can perform.

**ATDCTL5 — ATD Control Register 5**

**\$0065**

	Bit 7	6	5	4	3	2	1	Bit 0
	0	S8CM	SCAN	MULT	CD	CC	CB	CA
RESET:	0	0	0	0	0	0	0	0

The ATD control register 5 is used to select the conversion modes, the conversion channel(s), and initiate conversions.

Read or write anytime. A write to ATDCTL5 initiates a new conversion sequence. If a conversion sequence is in progress when a write occurs, that sequence is aborted and the SCF and CCF bits are reset.

**S8CM — Select 8 Channel Mode**

- 0 = Conversion sequence consists of four conversions
- 1 = Conversion sequence consists of eight conversions

**SCAN** — Enable Continuous Channel Scan

- 0 = Single conversion sequence
- 1 = Continuous conversion sequences (scan mode)

When a conversion sequence is initiated by a write to the ATDCTL register, the user has a choice of performing a sequence of four (or eight, depending on the S8CM bit) conversions or continuously performing four (or eight) conversion sequences.

**MULT** — Enable Multichannel Conversion

- 0 = ATD sequencer runs all four or eight conversions on a **single** input channel selected via the CD, CC, CB, and CA bits.
- 1 = ATD sequencer runs each of the four or eight conversions on **sequential** channels in a specific group. Refer to [Table 54](#).

**CD, CC, CB, and CA** — Channel Select for Conversion

**Table 54 Multichannel Mode Result Register Assignment**

S8CM	CD	CC	CB	CA	Channel Signal	Result in ADRx if MULT = 1
0	0	0	0	0	AN0	ADR0
			0	1	AN1	ADR1
			1	0	AN2	ADR2
			1	1	AN3	ADR3
0	0	1	0	0	AN4	ADR0
			0	1	AN5	ADR1
			1	0	AN6	ADR2
			1	1	AN7	ADR3
0	1	0	0	0	Reserved	ADR0
			0	1	Reserved	ADR1
			1	0	Reserved	ADR2
			1	1	Reserved	ADR3
0	1	1	0	0	V <sub>RH</sub>	ADR0
			0	1	V <sub>RL</sub>	ADR1
			1	0	(V <sub>RH</sub> + V <sub>RL</sub> )/2	ADR2
			1	1	TEST/Reserved	ADR3

Table 54 Multichannel Mode Result Register Assignment

S8CM	CD	CC	CB	CA	Channel Signal	Result in ADRx if MULT = 1
1	0	0	0	0	AN0	ADR0
		0	0	1	AN1	ADR1
		0	1	0	AN2	ADR2
		0	1	1	AN3	ADR3
		1	0	0	AN4	ADR4
		1	0	1	AN5	ADR5
		1	1	0	AN6	ADR6
		1	1	1	AN7	ADR7
1	1	0	0	0	Reserved	ADR0
		0	0	1	Reserved	ADR1
		0	1	0	Reserved	ADR2
		0	1	1	Reserved	ADR3
		1	0	0	V <sub>RH</sub>	ADR4
		1	0	1	V <sub>RL</sub>	ADR5
		1	1	0	(V <sub>RH</sub> + V <sub>RL</sub> )/2	ADR6
		1	1	1	TEST/Reserved	ADR7

Shaded bits are "don't care" if MULT = 1 and the entire block of four or eight channels make up a conversion sequence. When MULT = 0, all four bits (CD, CC, CB, and CA) must be specified and a conversion sequence consists of four or eight consecutive conversions of the single specified channel.

ATDSTAT — ATD Status Register

\$0066

	Bit 7	6	5	4	3	2	1	Bit 0
	SCF	0	0	0	0	CC2	CC1	CC0
RESET:	0	0	0	0	0	0	0	0

ATDSTAT — ATD Status Register

\$0067

	Bit 7	6	5	4	3	2	1	Bit 0
	CCF7	CCF6	CCF5	CCF4	CCF3	CCF2	CCF1	CCF0
RESET:	0	0	0	0	0	0	0	0

The ATD status registers contain the flags indicating the completion of ATD conversions.

Normally, it is read-only. In special mode, the SCF bit and the CCF bits may also be written.

**SCF — Sequence Complete Flag**

This bit is set at the end of the conversion sequence when in the single conversion sequence mode (SCAN = 0 in ATDCTL5) and is set at the end of the first conversion sequence when in the continuous conversion mode (SCAN = 1 in ATDCTL5). When AFFC = 0, SCF is cleared when a write is performed to ATDCTL5 to initiate a new conversion sequence. When AFFC = 1, SCF is cleared after the first result register is read.

**CC[2:0] — Conversion Counter for Current Sequence of Four or Eight Conversions**

This 3-bit value reflects the contents of the conversion counter pointer in a four or eight count sequence. This value also reflects which result register will be written next, indicating which channel is currently being converted.

**CCF[7:0] — Conversion Complete Flags**

Each of these bits are associated with an individual ATD result register. For each register, this bit is set at the end of conversion for the associated ATD channel and remains set until that ATD result register is read. It is cleared at that time if AFFC bit is set, regardless of whether a status register read has been performed (i.e., a status register read is not a pre-qualifier for the clearing mechanism when AFFC = 1). Otherwise the status register must be read to clear the flag.

**ATDTSTH — ATD Test Register**

**\$0068**

	Bit 7	6	5	4	3	2	1	Bit 0
	SAR9	SAR8	SAR7	SAR6	SAR5	SAR4	SAR3	SAR2
RESET:	0	0	0	0	0	0	0	0

**ATDTSTL — ATD Test Register**

**\$0069**

	Bit 7	6	5	4	3	2	1	Bit 0
	SAR1	SAR0	RST	TSTOUT	TST3	TST2	TST1	TST0
RESET:	0	0	0	0	0	0	0	0

The test registers control various special modes which are used during manufacturing. The test register can be read or written only in the special modes. In the normal modes, reads of the test register return zero and writes have no effect.

SAR[9:0] — SAR Data

Reads of this byte return the current value in the SAR. Writes to this byte change the SAR to the value written. Bits SAR[9:0] reflect the ten SAR bits used during the resolution process for an 10-bit result.

RST — Module Reset Bit

When set, this bit causes all registers and activity in the module to assume the same state as out of power-on reset (except for ADPU bit in ATDCTL2, which remains set, allowing the ATD module to remain enabled).

TSTOUT — Multiplex Output of TST[3:0] (Factory Use)

TST[3:0] — Test Bits 3 to 0 (Reserved)

Selects one of 16 reserved factory testing modes

PORTAD — Port AD Data Input Register

\$006F

	Bit 7	6	5	4	3	2	1	Bit 0
	PAD7	PAD6	PAD5	PAD4	PAD3	PAD2	PAD1	PAD0
RESET:	–	–	–	–	–	–	–	–

PAD[7:0] — Port AD Data Input Bits

After reset these bits reflect the state of the input pins.

May be used for general-purpose digital input. When the software reads PORTAD, it obtains the digital levels that appear on the corresponding port AD pins. Pins with signals not meeting  $V_{IL}$  or  $V_{IH}$  specifications will have an indeterminate value. Writes to this register have no meaning at any time.



<b>ADRx0H</b> — A/D Converter Result Register 0	<b>\$0070</b>
<b>ADRx0L</b> — A/D Converter Result Register 0	<b>\$0071</b>
<b>ADRx1H</b> — A/D Converter Result Register 1	<b>\$0072</b>
<b>ADRx1L</b> — A/D Converter Result Register 1	<b>\$0073</b>
<b>ADRx2H</b> — A/D Converter Result Register 2	<b>\$0074</b>
<b>ADRx2L</b> — A/D Converter Result Register 2	<b>\$0075</b>
<b>ADRx3H</b> — A/D Converter Result Register 3	<b>\$0076</b>
<b>ADRx3L</b> — A/D Converter Result Register 3	<b>\$0077</b>
<b>ADRx4H</b> — A/D Converter Result Register 4	<b>\$0078</b>
<b>ADRx4L</b> — A/D Converter Result Register 4	<b>\$0079</b>
<b>ADRx5H</b> — A/D Converter Result Register 5	<b>\$007A</b>
<b>ADRx5L</b> — A/D Converter Result Register 5	<b>\$007B</b>
<b>ADRx6H</b> — A/D Converter Result Register 6	<b>\$007C</b>
<b>ADRx6L</b> — A/D Converter Result Register 6	<b>\$007D</b>
<b>ADRx7H</b> — A/D Converter Result Register 7	<b>\$007E</b>
<b>ADRx7L</b> — A/D Converter Result Register 7	<b>\$007F</b>

ADRxH	Bit 15	14	13	12	11	10	9	Bit 8
ADRxL	Bit 7	6	0	0	0	0	0	0
RESET:	0	0	0	0	0	0	0	0

**ADRxH[15:8], ADRxL[7:0] — ATD Conversion Result**

The reset condition for these registers is undefined.

These bits contain the left justified, unsigned result from the ATD conversion. The channel from which this result was obtained is dependent on the conversion mode selected. These registers are always read-only in normal mode.

---

---

## ATD Mode Operation

STOP — causes all clocks to halt (if the S bit in the CCR is zero). The system is placed in a minimum-power standby mode. This aborts any conversion sequence in progress. During STOP recovery, the ATD must delay for the STOP recovery time ( $t_{SR}$ ) before initiating a new ATD conversion sequence.

WAIT — ATD conversion continues unless AWAI bit in ATDCTL2 register is set.

BDM — Debug options available as set in register ATDCTL3.

USER — ATD continues running unless ADPU is cleared.

ADPU — ATD operations are stopped if ADPU = 0, but registers are accessible.

# Development Support

---

---

## Contents

Introduction . . . . .	231
Instruction Queue . . . . .	231
Background Debug Mode . . . . .	233
Breakpoints . . . . .	247
Instruction Tagging . . . . .	253

---

---

## Introduction

Development support involves complex interactions between MC68HC912BD32 resources and external development systems. The following section concerns instruction queue and queue tracking signals, background debug mode, and instruction tagging.

---

---

## Instruction Queue

The CPU12 instruction queue provides at least three bytes of program information to the CPU when instruction execution begins. The CPU12 always completely finishes executing an instruction before beginning to execute the next instruction. Status signals IPIPE[1:0] provide information about data movement in the queue and indicate when the CPU begins to execute instructions. This makes it possible to monitor CPU activity on a cycle-by-cycle basis for debugging. Information available on the IPIPE[1:0] pins is time multiplexed. External circuitry can latch data movement information on rising edges of the E-clock signal; execution start information can be latched on falling edges. [Table 55](#) shows the meaning of data on the pins.

Table 55 IPIPE Decoding

Data Movement — IPIPE[1:0] Captured at Rising Edge of E Clock <sup>(1)</sup>		
IPIPE[1:0]	Mnemonic	Meaning
0:0	—	No Movement
0:1	LAT	Latch Data From Bus
1:0	ALD	Advance Queue and Load From Bus
1:1	ALL	Advance Queue and Load From Latch
Execution Start — IPIPE[1:0] Captured at Falling Edge of E Clock <sup>(2)</sup>		
IPIPE[1:0]	Mnemonic	Meaning
0:0	—	No Start
0:1	INT	Start Interrupt Sequence
1:0	SEV	Start Even Instruction
1:1	SOD	Start Odd Instruction

1. Refers to data that was on the bus at the previous E falling edge.
2. Refers to bus cycle starting at this E falling edge.

Program information is fetched a few cycles before it is used by the CPU. In order to monitor cycle-by-cycle CPU activity, it is necessary to externally reconstruct what is happening in the instruction queue. Internally the MCU only needs to buffer the data from program fetches. For system debug it is necessary to keep the data and its associated address in the reconstructed instruction queue. The raw signals required for reconstruction of the queue are ADDR, DATA, R/W, ECLK, and status signals IPIPE[1:0].

The instruction queue consists of two 16-bit queue stages and a holding latch on the input of the first stage. To advance the queue means to move the word in the first stage to the second stage and move the word from either the holding latch or the data bus input buffer into the first stage. To start even (or odd) instruction means to execute the opcode in the high-order (or low-order) byte of the second stage of the instruction queue.

---

---

## Background Debug Mode

Background debug mode (BDM) is used for system development, in-circuit testing, field testing, and programming. BDM is implemented in on-chip hardware and provides a full set of debug options.

Because BDM control logic does not reside in the CPU, BDM hardware commands can be executed while the CPU is operating normally. The control logic generally uses CPU dead cycles to execute these commands, but can steal cycles from the CPU when necessary. Other BDM commands are firmware based, and require the CPU to be in active background mode for execution. While BDM is active, the CPU executes a firmware program located in a small on-chip ROM that is available in the standard 64-Kbyte memory map only while BDM is active.

The BDM control logic communicates with an external host development system serially, via the BKGD pin. This single-wire approach minimizes the number of pins needed for development support.

### Enabling BDM Firmware Commands

BDM is available in all operating modes, but must be made active before firmware commands can be executed. BDM is enabled by setting the ENBDM bit in the BDM STATUS register via the single wire interface (using a hardware command; WRITE\_BD\_BYTE at \$FF01). BDM must then be activated to map BDM registers and ROM to addresses \$FF00 to \$FFFF and to put the MCU in active background mode.

After the firmware is enabled, BDM can be activated by the hardware BACKGROUND command, by the BDM tagging mechanism, or by the CPU BGND instruction. An attempt to activate BDM before firmware has been enabled causes the MCU to resume normal instruction execution after a brief delay.

BDM becomes active at the next instruction boundary following execution of the BDM BACKGROUND command, but tags activate BDM before a tagged instruction is executed.

In special single-chip mode, background operation is enabled and active immediately out of reset. This active case replaces the M68HC11 boot function, and allows programming a system with blank memory.

While BDM is active, a set of BDM control registers are mapped to addresses \$FF00 to \$FF06. The BDM control logic uses these registers which can be read anytime by BDM logic, not user programs. Refer to [BDM Registers](#) for detailed descriptions.

Some on-chip peripherals have a BDM control bit which allows suspending the peripheral function during BDM. For example, if the timer control is enabled, the timer counter is stopped while in BDM. Once normal program flow is continued, the timer counter is re-enabled to simulate real-time operations.

### BDM Serial Interface

The BDM serial interface requires the external controller to generate a falling edge on the BKGD pin to indicate the start of each bit time. The external controller provides this falling edge whether data is transmitted or received.

BKGD is a pseudo-open-drain pin that can be driven either by an external controller or by the MCU. Data is transferred MSB first at 16 B-clock cycles per bit (nominal speed). The interface times out if 512 B-clock cycles occur between falling edges from the host. The hardware clears the command register when a time-out occurs.

The BKGD pin can receive a high or low level or transmit a high or low level. The following diagrams show timing for each of these cases. Interface timing is synchronous to MCU clocks but asynchronous to the external host. The internal clock signal is shown for reference in counting cycles.

[Figure 56](#) shows an external host transmitting a logic one or zero to the BKGD pin of a target MC68HC912BD32 MCU. The host is asynchronous to the target so there is a 0-to-1 cycle delay from the host-generated falling edge to where the target perceives the beginning of the bit time. Ten target B cycles later, the target senses the bit level on the BKGD pin. Typically the host actively drives the pseudo-open-drain BKGD pin during host-to-target transmissions to

speed up rising edges. Since the target does not drive the BKGD pin during this period, there is no need to treat the line as an open-drain signal during host-to-target transmissions.

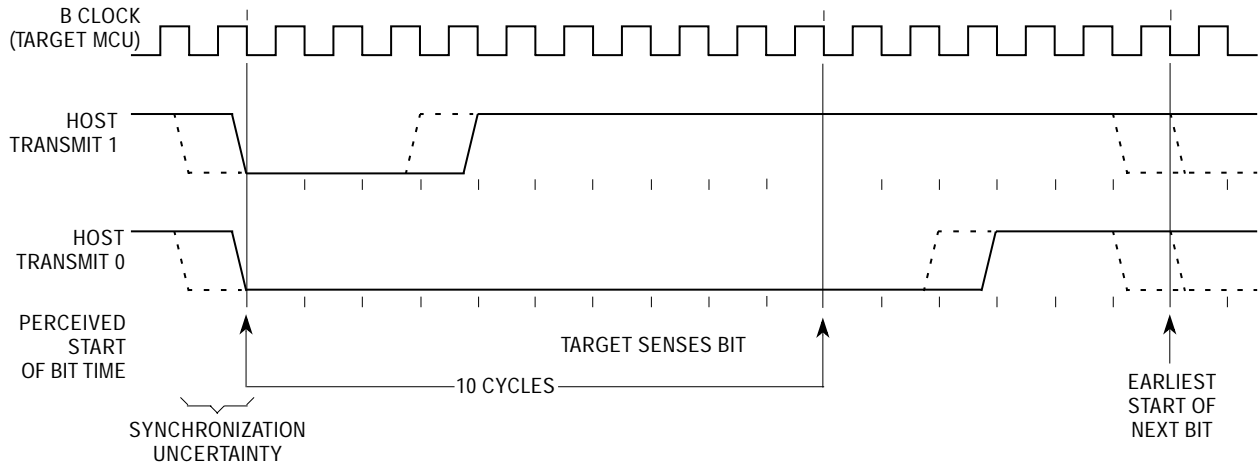

Figure 56 BDM Host to Target Serial Bit Timing

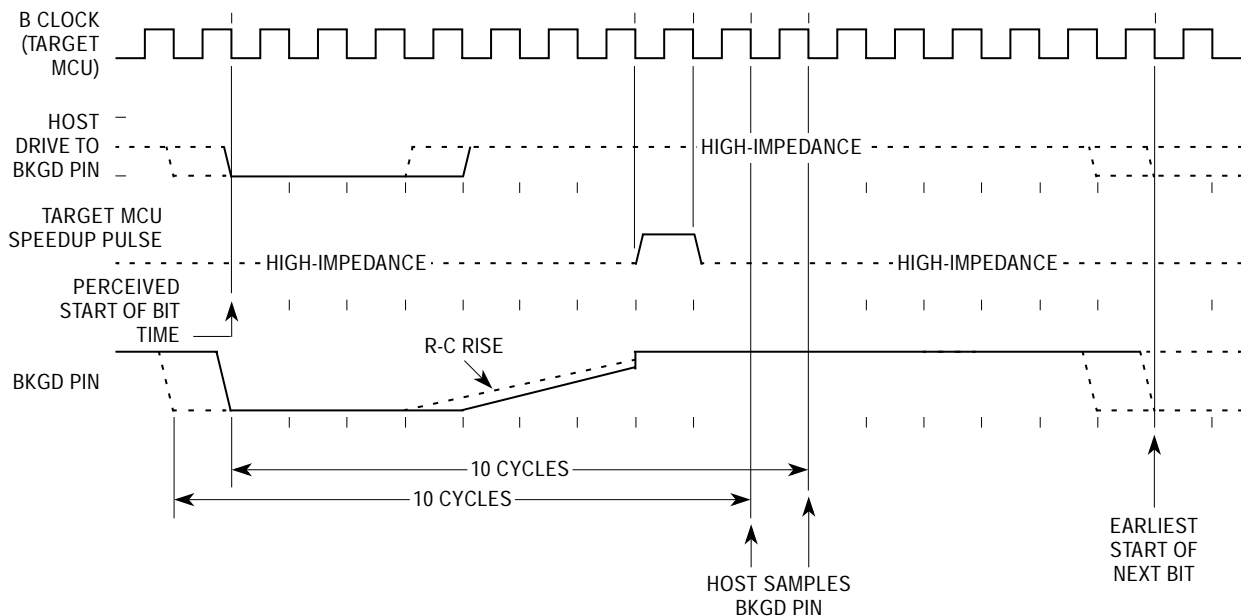

Figure 57 BDM Target to Host Serial Bit Timing (Logic 1)

Figure 57 shows the host receiving a logic one from the target MC68HC912BD32 MCU. Since the host is asynchronous to the target MCU, there is a 0-to-1 cycle delay from the host-generated falling edge on BKGD to the perceived start of the bit time in the target MCU. The host holds the BKGD pin low long enough for the target to recognize it (at least two target B cycles). The host must release the low drive before the target MCU drives a brief active-high speed-up pulse seven cycles after the perceived start of the bit time. The host should sample the bit level about ten cycles after it started the bit time.

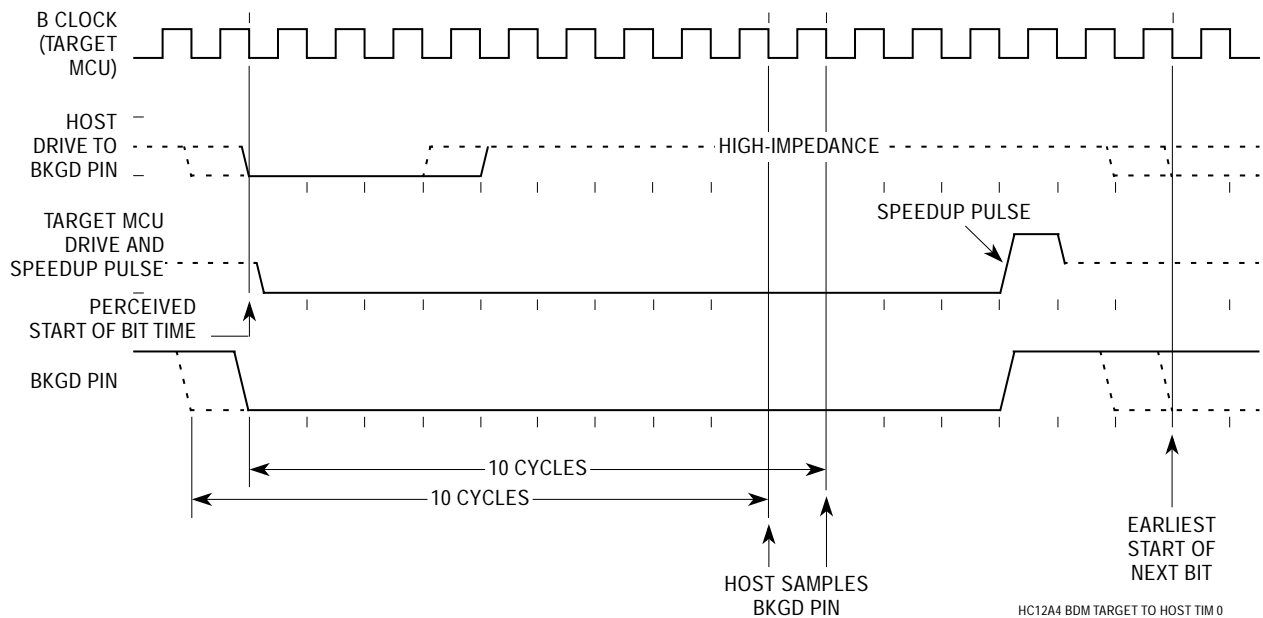

Figure 58 BDM Target to Host Serial Bit Timing (Logic 0)

Figure 58 shows the host receiving a logic zero from the target MC68HC912BD32 MCU. Since the host is asynchronous to the target MCU, there is a 0-to-1 cycle delay from the host-generated falling edge on BKGD to the start of the bit time as perceived by the target MCU. The host initiates the bit time but the target MC68HC912BD32 finishes it. Since the target wants the host to receive a logic zero, it drives the BKGD pin low for 13 B-clock cycles, then briefly drives it high to speed up the rising edge. The host samples the bit level about ten cycles after starting the bit time.



## BDM Commands

The BDM command set consists of two types: hardware and firmware. Hardware commands allow target system memory to be read or written. Target system memory includes all memory that is accessible by the CPU12 including EEPROM, on-chip I/O and control registers, and external memory that is connected to the target HC12 MCU. Hardware commands are implemented in hardware logic and do not require the HC12 MCU to be in BDM mode for execution. The control logic watches the CPU12 buses to find a free bus cycle to execute the command so the background access does not disturb the running application programs. If a free cycle is not found within 128 B-clock cycles, the CPU12 is momentarily frozen so the control logic can steal a cycle. Commands implemented in BDM control logic are listed in [Table 56](#).

**Table 56 Hardware Commands<sup>(1)</sup>**

Command	Opcode (Hex)	Data	Description
BACKGROUND	90	None	Enter background mode if firmware enabled.
READ_BD_BYTE <sup>(1)</sup>	E4	16-bit address 16-bit data out	Read from memory with BDM in map (may steal cycles if external access) data for odd address on low byte, data for even address on high byte.
READ_BD_WORD <sup>(1)</sup>	EC	16-bit address 16-bit data out	Read from memory with BDM in map (may steal cycles if external access). Must be aligned access.
READ_BYTE	E0	16-bit address 16-bit data out	Read from memory with BDM out of map (may steal cycles if external access) data for odd address on low byte, data for even address on high byte.
READ_WORD	E8	16-bit address 16-bit data out	Read from memory with BDM out of map (may steal cycles if external access). Must be aligned access.
WRITE_BD_BYTE <sup>(1)</sup>	C4	16-bit address 16-bit data in	Write to memory with BDM in map (may steal cycles if external access) data for odd address on low byte, data for even address on high byte.
WRITE_BD_WORD <sup>(1)</sup>	CC	16-bit address 16-bit data in	Write to memory with BDM in map (may steal cycles if external access). Must be aligned access.
WRITE_BYTE	C0	16-bit address 16-bit data in	Write to memory with BDM out of map (may steal cycles if external access) data for odd address on low byte, data for even address on high byte.
WRITE_WORD	C8	16-bit address 16-bit data in	Write to memory with BDM out of map (may steal cycles if external access). Must be aligned access.

1. Use these commands only for reading/writing to BDM locations. The BDM firmware ROM and BDM registers are not normally in the HC12 MCU memory map. Since these locations have the same addresses as some of the normal application memory map, there needs to be a way to decide which physical locations are being accessed by the hardware BDM commands. This gives rise to needing separate memory access commands for the BDM locations as opposed to the normal application locations. In logic, this is accomplished by momentarily enabling the BDM memory resources, just for the access cycles of the READ\_BD and WRITE\_BD commands. This logic allows the debugging system to unobtrusively access the BDM locations even if the application program is running out of the same memory area in the normal application memory map.

The second type of BDM commands are called firmware commands implemented in a small ROM within the HC12 MCU. The CPU must be in background mode to execute firmware commands. The usual way to get to background mode is by the hardware command BACKGROUND. The BDM ROM is located at \$FF20 to \$FFFF while BDM is active. There are also seven bytes of BDM registers located at \$FF00 to \$FF06 while BDM is active. The CPU executes code in the BDM firmware to perform the requested operation. The BDM firmware watches for serial commands and executes them as they are received. The firmware commands are shown in Table 57.

**Table 57 BDM Firmware Commands**

Command	Opcode (Hex)	Data	Description
READ_NEXT	62	16-bit data out	$X = X + 2$ ; Read next word pointed to by X
READ_PC	63	16-bit data out	Read program counter
READ_D	64	16-bit data out	Read D accumulator
READ_X	65	16-bit data out	Read X index register
READ_Y	66	16-bit data out	Read Y index register
READ_SP	67	16-bit data out	Read stack pointer
WRITE_NEXT	42	16-bit data in	$X = X + 2$ ; Write next word pointed to by X
WRITE_PC	43	16-bit data in	Write program counter
WRITE_D	44	16-bit data in	Write D accumulator
WRITE_X	45	16-bit data in	Write X index register
WRITE_Y	46	16-bit data in	Write Y index register
WRITE_SP	47	16-bit data in	Write stack pointer
GO	08	None	Go to user program
TRACE1	10	None	Execute one user instruction then return to BDM
TAGGO	18	None	Enable tagging and go to user program

Each of the hardware and firmware BDM commands start with an 8-bit command code (opcode). Depending upon the commands, a 16-bit address and/or a 16-bit data word is required as indicated in the tables by the command. All the read commands output 16-bits of data despite the byte/word implication in the command name.

The external host should wait 150 BCLK cycles for a non-intrusive BDM command to execute before another command is sent. This delay includes 128 BCLK cycles for the maximum delay for a free cycle. For

data read commands, the host must insert this delay between sending the address and attempting to read the data. In the case of a write command, the host must delay after the data portion, before sending a new command, to be sure the write has finished.

The external host should delay about 32 target BCLK cycles between a firmware read command and the data portion of these commands. This allows the BDM firmware to execute the instructions needed to get the requested data into the BDM SHIFTER register.

The external host should delay about 32 target BCLK cycles after the data portion of firmware write commands to allow BDM firmware to complete the requested write operation before a new serial command disturbs the BDM SHIFTER register.

The external host should delay about 64 target BCLK cycles after a TRACE1 or GO command before starting any new serial command. This delay is needed because the BDM SHIFTER register is used as a temporary data holding register during the exit sequence to user code.

BDM logic retains control of the internal buses until a read or write is completed. If an operation can be completed in a single cycle, it does not intrude on normal CPU12 operation. However, if an operation requires multiple cycles, CPU12 clocks are frozen until the operation is complete.

## BDM Lockout

The access to the MCU resources by BDM may be prevented by enabling the BDM lockout feature. When enabled, the BDM lockout mechanism prevents the BDM from being active. In this case the BDM ROM is disabled and does not appear in the MCU memory map.

The BDM lockout is enabled by clearing NOBDML bit of EEMCR register. The NOBDML bit is loaded at reset from the SHADOW byte of EEPROM module. Modifying the state of the NOBDML and corresponding EEPROM SHADOW bit is only possible in special modes.

Please refer to [EEPROM](#) for NOBDML information.

### Enabling the BDM lockout

Enabling the BDM lockout feature is only possible in special modes (SMODN=0) and is accomplished by the following steps.

1. Remove the SHADOW byte protection by clearing SHPROT bit in EEPROT register.
2. Clear NOSHB bit in EEMCR register to make the SHADOW byte visible at \$0FC0.
3. Program bit 7 of the SHADOW byte like a regular EEPROM location at address \$0FC0 (write \$7F into address \$0FC0). Do not program other bits of the SHADOW byte (location \$0FC0); otherwise some regular EEPROM array locations will not be visible. At the next reset, the SHADOW byte is loaded into the EEMCR register. NOBDML bit in EEMCR will be cleared and BDM will not be operational.
4. Protect the SHADOW byte by setting SHPROT bit in EEPROT register.

### Disabling the BDM lockout

Disabling the BDM lockout is only possible in special modes (SMODN=0). Follow the same steps as for enabling the BDM lockout, but erase the SHADOW byte.

At the next reset, the SHADOW byte is loaded into the EEMCR register. NOBDML bit in EEMCR will be set and BDM becomes operational.

### BDM Registers

Seven BDM registers are mapped into the standard 64-Kbyte address space when BDM is active. Mapping is shown in [Table 58](#).

**Table 58 BDM registers**

Address	Register
\$FF00	BDM Instruction Register
\$FF01	BDM Status Register
\$FF02 – \$FF03	BDM Shift Register
\$FF04 – \$FF05	BDM Address Register
\$FF06	BDM CCR Holding Register

The content of the INSTRUCTION register is determined by the type of background command being executed. The STATUS register indicates BDM operating conditions. The SHIFT register contains data being received or transmitted via the serial interface. The ADDRESS register is temporary storage for BDM commands. The CCRSAV register preserves the content of the CPU12 CCR while BDM is active.

The only registers of interest to users are the STATUS register and the CCRSAV register. The other BDM registers are only used by the BDM firmware to execute commands. The registers are accessed by means of the hardware READ\_BD and WRITE\_BD commands, but should not be written during BDM operation (except the CCRSAV register which could be written to modify the CCR value).

STATUS

The STATUS register is read and written by the BDM hardware as a result of serial data shifted in on the BKGD pin.

Read: all modes.

Write: Bits 3 through 5, and bit 7 are writable in all modes. Bit 6, BDMACT, can only be written if bit 7 H/F in the INSTRUCTION register is a zero. Bit 2, CLKSW, can only be written if bit 7 H/F in the INSTRUCTION register is a one. A user would never write ones to bits 3 through 5 because these bits are only used by BDM firmware.

STATUS — BDM Status Register<sup>(1)</sup>

\$FF01

	BIT 7	6	5	4	3	2	1	BIT 0	
	ENBDM	BDMACT	ENTAG	SDV	TRACE	CLKSW	-	-	
RESET:	0 (NOTE 1)	1	0	0	0	0	0	0	Special Single Chip & Periph
RESET:	0	0	0	0	0	0	0	0	All other modes

1. ENBDM is set to 1 by the firmware in Special Single Chip mode.

ENBDM — Enable BDM (permit active background debug mode)

0 = BDM cannot be made active (hardware commands still allowed).

1 = BDM can be made active to allow firmware commands.

### BDMACT — Background Mode Active Status

BDMACT becomes set as active BDM mode is entered so that the BDM firmware ROM is enabled and put into the map. BDMACT is cleared by a carefully timed store instruction in the BDM firmware as part of the exit sequence to return to user code and remove the BDM memory from the map. This bit has 4 clock cycles write delay.

0 = BDM is not active. BDM ROM and registers are not in map.

1 = BDM is active and waiting for serial commands. BDM ROM and registers are in map

**CAUTION:** *The user should be careful that the state of the BDMACT bit is not unintentionally changed with the WRITE\_NEXT firmware command. If it is unintentionally changed from 1 to 0, it will cause a system runaway because it would disable the BDM firmware ROM while the CPU12 was executing BDM firmware. The following two commands show how BDMACT may unintentionally get changed from 1 to 0.*

*WRITE\_X with data \$FEFE*

*WRITE\_NEXT with data \$C400*

*The first command writes the data \$FEFE to the X index register. The second command writes the data \$C4 to the \$FF00 INSTRUCTION register and also writes the data \$00 to the \$FF01 STATUS register.*

### ENTAG — Tagging Enable

Set by the TAGGO command and cleared when BDM mode is entered. The serial system is disabled and the tag function enabled 16 cycles after this bit is written.

0 = Tagging not enabled, or BDM active.

1 = Tagging active. BDM cannot process serial commands while tagging is active.

### SDV — Shifter Data Valid

Shows that valid data is in the serial interface shift register. Used by the BDM firmware.

0 = No valid data. Shift operation is not complete.

1 = Valid Data. Shift operation is complete.

### TRACE — Asserted by the TRACE1 command

## CLKSW — Clock Switch

0 = BDM system operates with BCLK.

1 = BDM system operates with ECLK.

The WRITE\_BD\_BYTE@FF01 command that changes CLKSW including 150 cycles after the data portion of the command should be timed at the old speed. Beginning with the start of the next BDM command, the new clock can be used for timing BDM communications.

If ECLK rate is slower than BCLK rate, CLKSW is ignored and BDM system is forced to operate with ECLK.

## INSTRUCTION – Hardware Instruction Decode

The INSTRUCTION register is written by the BDM hardware as a result of serial data shifted in on the BKGD pin. It is readable and writable in Special Peripheral mode on the parallel bus. It is discussed here for two conditions: when a **hardware** command is executed and when a **firmware** command is executed.

Read and write: all modes

. The hardware clears the INSTRUCTION register if 512 BCLK cycles occur between falling edges from the host.

## INSTRUCTION — BDM Instruction Register (hardware command explanation)

**\$FF00**

	BIT 7	6	5	4	3	2	1	BIT 0
	H/F	DATA	R/W	BKGDND	W/B	BD/U	0	0
RESET:	0	0	0	0	0	0	0	0

The bits in the BDM instruction register have the following meanings when a **hardware** command is executed.

H/F — Hardware/Firmware Flag

0 = Firmware command

1 = Hardware command

DATA — Data Flag – Shows that data accompanies the command.

0 = No data

1 = Data follows the command

R/W — Read/Write Flag

0 = Write

1 = Read

BKGND — Hardware request to enter active background mode

0 = Not a hardware background command

1 = Hardware background command (INSTRUCTION = \$90)

W/B — Word/Byte Transfer Flag

0 = Byte transfer

1 = Word transfer

BD/U — BDM Map/User Map Flag

Indicates whether BDM registers and ROM are mapped to addresses \$FF00 to \$FFFF in the standard 64-Kbyte address space. Used only by hardware read/write commands.

0 = BDM resources not in map

1 = BDM ROM and registers in map

**INSTRUCTION** — BDM Instruction Register (firmware command bit explanation)

**\$FF00**

Bit 7	6	5	4	3	2	1	Bit 0
H/F	DATA	R/W	TTAGO		REGN		

The bits in the BDM instruction register have the following meanings when a **firmware** command is executed.

H/F — Hardware/Firmware Flag

0 = Firmware command

1 = Hardware command

DATA — Data Flag – Shows that data accompanies the command.

0 = No data

1 = Data follows the command

R/W — Read/Write Flag

0 = Write

1 = Read



TTAGO — Trace, Tag, Go Field

**Table 59 TTAGO Decoding**

TTAGO Value	Instruction
00	—
01	GO
10	TRACE1
11	TAGGO

REGN — Register/Next Field

Indicates which register is being affected by a command. In the case of a READ\_NEXT or WRITE\_NEXT command, index register X is pre-incremented by 2 and the word pointed to by X is then read or written.

**Table 60 REGN Decoding**

REGN Value	Instruction
000	—
001	—
010	READ/WRITE NEXT
011	PC
100	D
101	X
110	Y
111	SP

*SHIFTER*

This 16-bit shift register contains data being received or transmitted via the serial interface. It is also used by the BDM firmware for temporary storage.

Read: all modes (but not normally accessed by users)

Write: all modes (but not normally accessed by users)

**SHIFTER — BDM Shift Register – High Byte**

**\$FF02**

	BIT 15	14	13	12	11	10	9	BIT 8
	S15	S14	S13	S12	S11	S10	S9	S8
RESET:	X	X	X	X	X	X	X	X

**SHIFTER — BDM Shift Register – Low Byte**

**\$FF03**

	BIT 7	6	5	4	3	2	1	BIT 0
	S7	S6	S5	S4	S3	S2	S1	S0
RESET:	X	X	X	X	X	X	X	X

*ADDRESS*

This 16-bit address register is temporary storage for BDM hardware and firmware commands.

Read: all modes (but not normally accessed by users)

Write: only by BDM hardware (state machine)

**ADDRESS — BDM Address Register – High Byte**

**\$FF04**

	BIT 15	14	13	12	11	10	9	BIT 8
	A15	A14	A13	A12	A11	A10	A9	A8
RESET:	X	X	X	X	X	X	X	X

**ADDRESS — BDM Address Register – High Byte**

**\$FF05**

	BIT 7	6	5	4	3	2	1	BIT 0
	A7	A6	A5	A4	A3	A2	A1	A0
RESET:	X	X	X	X	X	X	X	X

CCRS<sub>AV</sub>

The CCR<sub>SAV</sub> register is used to save the CCR of the users program when entering BDM. It is also used for temporary storage in the BDM firmware.

Read and write: all modes

**CCRS<sub>AV</sub> — BDM CCR Holding Register**

**\$FF06**

	BIT 7	6	5	4	3	2	1	BIT 0
	CCR7	CCR6	CCR5	CCR4	CCR3	CCR2	CCR1	CCR0
RESET: NOTE 1 (1)	X	X	X	X	X	X	X	X

1. Initialized to equal the CPU12 CCR register by the firmware.

---



---

## Breakpoints

Hardware breakpoints are used to debug software on the MC68HC912BD32 by comparing actual address and data values to predetermined data in setup registers. A successful comparison will place the CPU in background debug mode (BDM) or initiate a software interrupt (SWI). Breakpoint features designed into the BDM256 include:

- Mode selection for BDM or SWI generation
- Program fetch tagging for cycle of execution breakpoint
- Second address compare in dual address modes
- Range compare by disable of low byte address
- Data compare in full feature mode for non-tagged breakpoint
- Byte masking for high/low byte data compares
- R/W compare for non-tagged compares
- Tag inhibit on BDM TRACE

- Breakpoint Modes** Three modes of operation determine the type of breakpoint in effect.
- Dual address-only breakpoints, each of which will cause a software interrupt (SWI)
  - Single full-feature breakpoint which will cause the part to enter background debug mode (BDM)
  - Dual address-only breakpoints, each of which will cause the part to enter BDM

Breakpoints will not occur when BDM is active.

### *SWI Dual Address Mode*

In this mode, dual address-only breakpoints can be set, each of which cause a software interrupt. This is the only breakpoint mode which can force the CPU to execute a SWI. Program fetch tagging is the default in this mode; data breakpoints are not possible. In the dual mode each address breakpoint is affected by the BKPM bit and the BKALE bit. The BKxRW and BKxRWE bits are ignored. In dual address mode the BKDBE becomes an enable for the second address breakpoint. The BKSZ8 bit will have no effect when in a dual address mode.

### *BDM Full Breakpoint Mode*

A single full feature breakpoint which causes the part to enter background debug mode. BDM mode may be entered by a breakpoint only if an internal signal from the BDM indicates background debug mode is enabled.

- Breakpoints are not allowed if the BDM mode is already active. Active mode means the CPU is executing out of the BDM ROM.
- BDM should not be entered from a breakpoint unless the ENABLE bit is set in the BDM. This is important because even if the ENABLE bit in the BDM is negated the CPU actually does execute the BDM ROM code. It checks the ENABLE and returns if not set. If the BDM is not serviced by the monitor then the breakpoint would be re-asserted when the BDM returns to normal CPU flow.
- There is no hardware to enforce restriction of breakpoint operation if the BDM is not enabled.

## *BDM Dual Address Mode*

Dual address-only breakpoints, each of which cause the part to enter background debug mode. In the dual mode each address breakpoint is affected, consistent across modes, by the BKPM bit, the BKALE bit, and the BKxRW and BKxRWE bits. In dual address mode the BKDBE becomes an enable for the second address breakpoint. The BKSZ8 bit will have no effect when in a dual address mode. BDM mode may be entered by a breakpoint only if an internal signal from the BDM indicates background debug mode is enabled.

- BKDBE will be used as an enable for the second address only breakpoint.
- Breakpoints are not allowed if the BDM mode is already active. Active mode means the CPU is executing out of the BDM ROM.
- BDM should not be entered from a breakpoint unless the ENABLE bit is set in the BDM. This is important because even if the ENABLE bit in the BDM is negated the CPU actually does execute the BDM ROM code. It checks the ENABLE and returns if not set. If the BDM is not serviced by the monitor then the breakpoint would be re-asserted when the BDM returns to normal CPU flow. There is no hardware to enforce restriction of breakpoint operation if the BDM is not enabled.

## **Breakpoint Registers**

Breakpoint operation consists of comparing data in the breakpoint address registers (BRKAH/BRKAL) to the address bus and comparing data in the breakpoint data registers (BRKDH/BRKDL) to the data bus. The breakpoint data registers can also be compared to the address bus. The scope of comparison can be expanded by ignoring the least significant byte of address or data matches.

The scope of comparison can be limited to program data only by setting the BKPM bit in breakpoint control register 0.

To trace program flow, setting the BKPM bit causes address comparison of program data only. Control bits are also available that allow checking read/write matches.

**BRKCT0** — Breakpoint Control Register 0

**\$0020**

	Bit 7	6	5	4	3	2	1	Bit 0
	BKEN1	BKEN0	BKPM	0	BK1ALE	BK0ALE	0	0
RESET:	0	0	0	0	0	0	0	0

Read and write anytime.

This register is used to control the breakpoint logic.

BKEN1, BKEN0 — Breakpoint Mode Enable

**Table 61 Breakpoint Mode Control**

BKEN1	BKEN0	Mode Selected	BRKAH/L Usage	BRKDH/L Usage	R/W	Range
0	0	Breakpoints Off	—	—	—	—
0	1	SWI — Dual Address Mode	Address Match	Address Match	No	Yes
1	0	BDM — Full Breakpoint Mode	Address Match	Data Match	Yes	Yes
1	1	BDM — Dual Address Mode	Address Match	Address Match	Yes	Yes

**BKPM** — Break on Program Addresses

This bit controls whether the breakpoint will cause a break on a match (next instruction boundary) or on a match that will be an executable opcode. Data and non-executed opcodes cannot cause a break if this bit is set. This bit has no meaning in SWI dual address mode. The SWI mode only performs program breakpoints.

0 = On match, break at the next instruction boundary

1 = On match, break if the match is an instruction that will be executed. This uses tagging as its breakpoint mechanism.

**BK1ALE** — Breakpoint 1 Range Control

Only valid in dual address mode.

0 = BRKDL will not be used to compare to the address bus.

1 = BRKDL will be used to compare to the address bus.

**BK0ALE** — Breakpoint 0 Range Control

Valid in all modes.

0 = BRKAL will not be used to compare to the address bus.

1 = BRKAL will be used to compare to the address bus.

**Table 62 Breakpoint Address Range Control**

BK1ALE	BK0ALE	Address Range Selected
–	0	Upper 8-bit address only for full mode or dual mode BKP0
–	1	Full 16-bit address for full mode or dual mode BKP0
0	–	Upper 8-bit address only for dual mode BKP1
1	–	Full 16-bit address for dual mode BKP1

**BRKCT1 — Breakpoint Control Register 1**

**\$0021**

	Bit 7	6	5	4	3	2	1	Bit 0
	0	BKDBE	BKMBH	BKMBL	BK1RWE	BK1RW	BK0RWE	BK0RW
RESET:	0	0	0	0	0	0	0	0

This register is read/write in all modes.

**BKDBE — Enable Data Bus**

Enables comparing of address or data bus values using the BRKDH/L registers.

0 = The BRKDH/L registers are not used in any comparison

1 = The BRKDH/L registers are used to compare address or data (depending upon the mode selections BKEN1,0)

**BKMBH — Breakpoint Mask High**

Disables the comparing of the high byte of data when in full breakpoint mode. Used in conjunction with the BKDBE bit (which should be set)

0 = High byte of data bus (bits 15:8) are compared to BRKDH

1 = High byte is not used to in comparisons

**BKMBL — Breakpoint Mask Low**

Disables the matching of the low byte of data when in full breakpoint mode. Used in conjunction with the BKDBE bit (which should be set)

0 = Low byte of data bus (bits 7:0) are compared to BRKDL

1 = Low byte is not used to in comparisons.

**BK1RWE — R/W Compare Enable**

Enables the comparison of the R/W signal to further specify what causes a match. This bit is NOT useful in program breakpoints or in full breakpoint mode. This bit is used in conjunction with a second address in dual address mode when BKDBE=1.

0 = R/W is not used in comparisons

1 = R/W is used in comparisons

**BK1RW — R/W Compare Value**

When BK1RWE = 1, this bit determines the type of bus cycle to match.

0 = A write cycle will be matched

1 = A read cycle will be matched

**BK0RWE — R/W Compare Enable**

Enables the comparison of the R/W signal to further specify what causes a match. This bit is not useful in program breakpoints.

0 = R/W is not used in the comparisons

1 = R/W is used in comparisons

**BK0RW — R/W Compare Value**

When BK0RWE = 1, this bit determines the type of bus cycle to match on.

0 = Write cycle will be matched

1 = Read cycle will be matched

**Table 63 Breakpoint Read/Write Control**

BK1RWE	BK1RW	BK0RWE	BK0RW	Read/Write Selected
–	–	0	X	R/W is don't care for full mode or dual mode BKP0
–	–	1	0	R/W is write for full mode or dual mode BKP0
–	–	1	1	R/W is read for full mode or dual mode BKP0
0	X	–	–	R/W is don't care for dual mode BKP1
1	0	–	–	R/W is write for dual mode BKP1
1	1	–	–	R/W is read for dual mode BKP1

**BRKAH — Breakpoint Address Register, High Byte**

**\$0022**

Bit 7	6	5	4	3	2	1	Bit 0
Bit 15	14	13	12	11	10	9	Bit 8
RESET:	0	0	0	0	0	0	0

These bits are used to compare against the most significant byte of the address bus.



**BRKAL** — Breakpoint Address Register, Low Byte

**\$0023**

	Bit 7	6	5	4	3	2	1	Bit 0
	Bit 7	6	5	4	3	2	1	Bit 0
RESET:	0	0	0	0	0	0	0	0

These bits are used to compare against the least significant byte of the address bus. These bits may be excluded from being used in the match if BK0ALE = 0.

**BRKDH** — Breakpoint Data Register, High Byte

**\$0024**

	Bit 7	6	5	4	3	2	1	Bit 0
	Bit 15	14	13	12	11	10	9	Bit 8
RESET:	0	0	0	0	0	0	0	0

These bits are compared to the most significant byte of the data bus or the most significant byte of the address bus in dual address modes. BKEN[1:0], BKDBE, and BKMBH control how this byte will be used in the breakpoint comparison.

**BRKDL** — Breakpoint Data Register, Low Byte

**\$0025**

	Bit 7	6	5	4	3	2	1	Bit 0
	Bit 7	6	5	4	3	2	1	Bit 0
RESET:	0	0	0	0	0	0	0	0

These bits are compared to the least significant byte of the data bus or the least significant byte of the address bus in dual address modes. BKEN[1:0], BKDBE, BK1ALE, and BKMBL control how this byte will be used in the breakpoint comparison.

---



---

**Instruction Tagging**

The instruction queue and cycle-by-cycle CPU activity can be reconstructed in real time or from trace history that was captured by a logic analyzer. However, the reconstructed queue cannot be used to stop the CPU at a specific instruction, because execution has already

begun by the time an operation is visible outside the MCU. A separate instruction tagging mechanism is provided for this purpose.

Executing the BDM TAGGO command configures two MCU pins for tagging. The  $\overline{\text{TAGLO}}$  signal shares a pin with the  $\overline{\text{LSTRB}}$  signal, and the  $\overline{\text{TAGHI}}$  signal shares a pin with the BKGD signal. Tagging information is latched on the falling edge of ECLK.

Table 64 shows the functions of the two tagging pins. The pins operate independently - the state of one pin does not affect the function of the other. The presence of logic level zero on either pin at the fall of ECLK performs the indicated function. Tagging is allowed in all modes. Tagging is disabled when BDM becomes active and BDM serial commands are not processed while tagging is active.

**Table 64 Tag Pin Function**

$\overline{\text{TAGHI}}$	$\overline{\text{TAGLO}}$	Tag
1	1	no tag
1	0	low byte
0	1	high byte
0	0	both bytes

The tag follows program information as it advances through the queue. When a tagged instruction reaches the head of the queue, the CPU enters active background debugging mode rather than execute the instruction.

# Preliminary Electrical Characteristics

This section contains the most accurate electrical information for the MC68HC912BD32 microcontroller available at the time of publication. The information should be considered preliminary and is subject to change. The following characteristics are contained in this document:

**Table 65 Maximum Ratings<sup>(1)</sup>**

Rating	Symbol	Value	Unit
Supply voltage	$V_{DD}, V_{DDA}, V_{DDX}$	-0.3 to +6.5	V
Input voltage	$V_{IN}$	-0.3 to +6.5	V
Operating temperature range MC68HC912BD32FU MC68HC912BD32CFU	$T_A$	$T_L$ to $T_H$ 0 to +70 -40 to +85	°C
Storage temperature range	$T_{stg}$	-55 to +150	°C
Current drain per pin <sup>(2)</sup> Excluding $V_{DD}$ and $V_{SS}$	$I_{IN}$	±25	mA
$V_{DD}$ differential voltage	$V_{DD}-V_{DDX}$	6.5	V

1. Permanent damage can occur if maximum ratings are exceeded. Exposures to voltages or currents in excess of recommended values affects device reliability. Device modules may not operate normally while being exposed to electrical extremes.
2. One pin at a time, observing maximum power dissipation limits. Internal circuitry protects the inputs against damage caused by high static voltages or electric fields; however, normal precautions are necessary to avoid application of any voltage higher than maximum-rated voltages to this high-impedance circuit. Extended operation at the maximum ratings can adversely affect device reliability. Tying unused inputs to an appropriate logic voltage level (either GND or  $V_{DD}$ ) enhances reliability of operation.

Table 66 Thermal Characteristics

Characteristic	Symbol	Value	Unit
Average junction temperature	$T_J$	$T_A + (P_D \times \Theta_{JA})$	$^{\circ}\text{C}$
Ambient temperature	$T_A$	User-determined	$^{\circ}\text{C}$
Package thermal resistance (junction-to-ambient) 80-pin quad flat pack (QFP)	$\Theta_{JA}$	85	$^{\circ}\text{C}/\text{W}$
Total power dissipation <sup>(1)</sup>	$P_D$	$\frac{P_{INT} + P_{I/O}}{K}$ $\frac{K}{T_J + 273^{\circ}\text{C}}$	W
Device internal power dissipation	$P_{INT}$	$I_{DD} \times V_{DD}$	W
I/O pin power dissipation <sup>(2)</sup>	$P_{I/O}$	User-determined	W
A constant <sup>(3)</sup>	K	$P_D \times (T_A + 273^{\circ}\text{C}) + \Theta_{JA} \times P_D^2$	$\text{W} \cdot ^{\circ}\text{C}$

1. This is an approximate value, neglecting  $P_{I/O}$ .

2. For most applications  $P_{I/O} \ll P_{INT}$  and can be neglected.

3. K is a constant pertaining to the device. Solve for K with a known  $T_A$  and a measured  $P_D$  (at equilibrium). Use this value of K to solve for  $P_D$  and  $T_J$  iteratively for any value of  $T_A$ .

**Table 67 DC Electrical Characteristics**

$V_{DD} = 5.0 \text{ Vdc} \pm 5\%$ ,  $V_{SS} = 0 \text{ Vdc}$ ,  $T_A = T_L$  to  $T_H$ , unless otherwise noted

Characteristic	Symbol	Min	Max	Unit
Input high voltage, all inputs	$V_{IH}$	$0.7 \times V_{DD}$	$V_{DD} + 0.3$	V
Input low voltage, all inputs	$V_{IL}$	$V_{SS} - 0.3$	$0.2 \times V_{DD}$	V
Output high voltage, all I/O and output pins except XTAL Normal drive strength $I_{OH} = -10.0 \mu\text{A}$ $I_{OH} = -0.8 \text{ mA}$	$V_{OH}$	$V_{DD} - 0.2$	—	V
		$V_{DD} - 0.8$	—	V
Reduced drive strength $I_{OH} = -4.0 \mu\text{A}$ $I_{OH} = -0.3 \text{ mA}$		$V_{DD} - 0.2$	—	V
		$V_{DD} - 0.8$	—	V
Output low voltage, all I/O and output pins except XTAL Normal drive strength $I_{OL} = 10.0 \mu\text{A}$ $I_{OL} = 1.6 \text{ mA}$	$V_{OL}$	—	$V_{SS} + 0.2$	V
		—	$V_{SS} + 0.4$	V
Reduced drive strength $I_{OL} = 3.6 \mu\text{A}$ $I_{OL} = 0.6 \text{ mA}$		—	$V_{SS} + 0.2$	V
		—	$V_{SS} + 0.4$	V
Input leakage current <sup>(1)</sup> $V_{in} = V_{DD}$ or $V_{SS}$ All input only pins except $\overline{\text{IRQ}}$ , $\text{ATD}^{(2)}$ and $V_{FP}$ $V_{in} = V_{DD}$ or $V_{SS}$ $\overline{\text{IRQ}}$	$I_{in}$	—	$\pm 2.5$	$\mu\text{A}$
		—	$\pm 10$	$\mu\text{A}$
Three-state leakage, I/O ports, BKGD, and $\overline{\text{RESET}}$	$I_{OZ}$	—	$\pm 2.5$	$\mu\text{A}$
Input capacitance All input pins and ATD pins (non-sampling) ATD pins (sampling) All I/O pins	$C_{in}$	—	10	pF
		—	15	pF
		—	20	pF
Output load capacitance All outputs except PS[7:4] PS[7:4] when configured as SPI	$C_L$	—	90	pF
		—	200	pF
Programmable active pull-up current $\overline{\text{XIRQ}}$ , $\overline{\text{DBE}}$ , $\overline{\text{LSTRB}}$ , R/W, ports A, B, SBI, P, S, T MODA, MODB active pull down during reset BKGD passive pull up	$I_{APU}$	50	500	$\mu\text{A}$
		50	500	$\mu\text{A}$
		50	500	$\mu\text{A}$

1. Specification is for parts in the -40 to +85° C range. Higher temperature ranges will result in increased current leakage.

2. See [ATD DC Electrical Characteristics](#).

Preliminary Electrical Characteristics

Table 68 Supply Current

$V_{DD} = 5.0 \text{ Vdc} \pm 5\%$ ,  $V_{SS} = 0 \text{ Vdc}$ ,  $T_A = T_L$  to  $T_H$ , unless otherwise noted

Characteristic	Symbol	8 MHz Typical	4 MHz	8 MHz	10 MHz	Unit
Maximum total supply current <b>RUN:</b> Single-chip mode Expanded mode	$I_{DD}$		30 50	50 75	60 90	mA mA
<b>WAIT:</b> (All peripheral functions shut down) Single-chip mode Expanded mode	$W_{IDD}$		3 7	5 10	6 12	mA mA
<b>STOP:</b> Single-chip mode, no clocks -40 to +85	$S_{IDD}$		10	10	10	$\mu\text{A}$
Maximum power dissipation <sup>(1)</sup> Single-chip mode Expanded mode	$P_D$		150 250	250 375	300 450	mW mW

1. Includes  $I_{DD}$  and  $I_{DDA}$ .

Table 69 ATD Maximum Ratings

Characteristic	Symbol	Value	Units
ATD reference voltage $V_{RH} \leq V_{DDA}$ $V_{RL} \geq V_{SSA}$	$V_{RH}$ $V_{RL}$	-0.3 to +6.5 -0.3 to +6.5	V V
$V_{SS}$ differential voltage	$ V_{SS} - V_{SSA} $	0.1	V
$V_{DD}$ differential voltage	$V_{DD} - V_{DDA}$ $V_{DDA} - V_{DD}$	6.5 0.3	V V
$V_{REF}$ differential voltage	$ V_{RH} - V_{RL} $	6.5	V
Reference to supply differential voltage	$ V_{RH} - V_{DDA} $	6.5	V

### Table 70 ATD DC Electrical Characteristics

$V_{DD} = 5.0 \text{ Vdc} \pm 5\%$ ,  $V_{SS} = 0 \text{ Vdc}$ ,  $T_A = T_L$  to  $T_H$ , ATD Clock = 2 MHz, unless otherwise noted

Characteristic	Symbol	Min	Max	Unit
Analog supply voltage	$V_{DDA}$	4.75	5.25	V
Analog supply current, normal operation	$I_{DDA}$		1.0	mA
Reference voltage, low	$V_{RL}$	$V_{SSA}$	$V_{DDA}/2$	V
Reference voltage, high	$V_{RH}$	$V_{DDA}/2$	$V_{DDA}$	V
$V_{REF}$ differential reference voltage <sup>(1)</sup>	$V_{RH} - V_{RL}$	4.75	5.25	V
Input voltage <sup>(2)</sup>	$V_{INDC}$	$V_{SSA}$	$V_{DDA}$	V
Input current, off channel <sup>(3)</sup>	$I_{OFF}$		100	nA
Reference supply current	$I_{REF}$		250	$\mu\text{A}$
Input capacitance Not Sampling	$C_{INN}$		10	pF
Sampling	$C_{INS}$		15	pF

1. Accuracy is guaranteed at  $V_{RH} - V_{RL} = 5.0\text{V} \pm 5\%$ .

2. To obtain full-scale, full-range results,  $V_{SSA} \leq V_{RL} \leq V_{INDC} \leq V_{RH} \leq V_{DDA}$ .

3. Maximum leakage occurs at maximum operating temperature. Current decreases by approximately one-half for each 10°C decrease from maximum temperature.

Preliminary Electrical Characteristics

**Table 71 Analog Converter Characteristics (Operating)**

$V_{DD} = 5.0 \text{ Vdc} \pm 5\%$ ,  $V_{SS} = 0 \text{ Vdc}$ ,  $T_A = T_L \text{ to } T_H$ , ATD Clock = 2 MHz, unless otherwise noted

Characteristic	Symbol	Min	Typical	Max	Unit
8-Bit resolution <sup>(1)</sup>	1 count		20		mV
8-Bit Differential non-linearity <sup>(2)</sup>	DNL	-0.5		+0.5	count
8-Bit Integral non-linearity <sup>(2)</sup>	INL	-1		+1	count
8- Bit Absolute error <sup>(2),(3)</sup>	AE	-1		+1	count
10-Bit Resolution <sup>1</sup>	1 count		5		mV
10-Bit Differential non-linearity <sup>(2)</sup>	DNL	-1		1	count
10-Bit Integral non-linearity <sup>(2)</sup>	INL	-2		2	count
10-Bit Absolute error <sup>(2),(3)</sup>	AE	-2		2	count
Maximum source impedance	$R_S$		20	See note <sup>(4)</sup>	$K\Omega$

1.  $V_{RH} - V_{RL} \geq 5.12V$ ;  $V_{DDA} - V_{SSA} = 5.12V$

2. At  $V_{REF} = 5.12V$ , one 8-bit count = 20 mV, and one 10-bit count = 5mV.

3. These values include quantization error which is inherently 1/2 count for any A/D converter.

4. Maximum source impedance is application-dependent. Error resulting from pin leakage depends on junction leakage into the pin and on leakage due to charge-sharing with internal capacitance. Error from junction leakage is a function of external source impedance and input leakage current. Expected error in result value due to junction leakage is expressed in voltage ( $V_{ERRJ}$ ):

$$V_{ERRJ} = R_S \times I_{OFF}$$

where  $I_{OFF}$  is a function of operating temperature. Charge-sharing effects with internal capacitors are a function of ATD clock speed, the number of channels being scanned, and source impedance. For 8-bit conversions, charge pump leakage is computed as follows:

$$V_{ERRJ} = .25pF \times V_{DDA} \times R_S \times ATDCLK / (8 \times \text{number of channels})$$



### Table 72 ATD AC Characteristics (Operating)

$V_{DD} = 5.0 \text{ Vdc} \pm 5\%$ ,  $V_{SS} = 0 \text{ Vdc}$ ,  $T_A = T_L$  to  $T_H$ , ATD Clock = 2 MHz, unless otherwise noted

Characteristic	Symbol	Min	Max	Unit
MCU clock frequency (p-clock)	$f_{PCLK}$	2.0	10.0	MHz
ATD operating clock frequency	$f_{ATDCLK}$	0.5	2.0	MHz
ATD 8-Bit conversion period clock cycles <sup>(1)</sup> conversion time <sup>(2)</sup>	$n_{CONV8}$ $t_{CONV8}$	18 9	32 16	cycles $\mu\text{s}$
ATD 10-Bit conversion period clock cycles <sup>1</sup> conversion time <sup>2</sup>	$n_{CONV10}$ $t_{CONV10}$	20 10	34 17	cycles $\mu\text{s}$
Stop and ATD power up recovery time <sup>(3)</sup> $V_{DDA} = 5.0\text{V}$	$t_{SR}$		10	$\mu\text{s}$

1. The minimum time assumes a final sample period of 2 ATD clock cycles while the maximum time assumes a final sample period of 16ATD clocks.
2. This assumes an ATD clock frequency of 2.0MHz.
3. From the time ADPU is asserted until the time an ATD conversion can begin.

### Table 73 EEPROM Characteristics

$V_{DD} = 5.0 \text{ Vdc} \pm 5\%$ ,  $V_{SS} = 0 \text{ Vdc}$ ,  $T_A = T_L$  to  $T_H$ , unless otherwise noted

Characteristic	Symbol	Min	Typical	Max	Unit
Minimum programming clock frequency <sup>(1)</sup>	$f_{PROG}$	1.0			MHz
Programming time	$t_{PROG}$			10	ms
Clock recovery time, following STOP, to continue programming	$t_{CRSTOP}$			$t_{PROG} + 1$	ms
Erase time	$t_{ERASE}$			10	ms
Write/erase endurance		10,000	30,000 <sup>(2)</sup>		cycles
Data retention		10			years

1. RC oscillator must be enabled if programming is desired and  $f_{SYS} < f_{PROG}$ .
2. If average  $T_H$  is below 85° C.

**Table 74 Flash EEPROM Characteristics**

$V_{DD} = 5.0 \text{ Vdc} \pm 5\%$ ,  $V_{SS} = 0 \text{ Vdc}$ ,  $T_A = T_L \text{ to } T_H$ , unless otherwise noted

Characteristic	Symbol	Min	Typical	Max	Units
Program/erase supply voltage: Read only Program / erase / verify <sup>(1)</sup>	$V_{FP}$	$V_{DD}-0.5$ 11.4	$V_{DD}$ 12.0	$V_{DD}+0.5$ 12.6	V V
Program/erase supply current Word program ( $V_{FP} = 12\text{V}$ ) Erase ( $V_{FP} = 12\text{V}$ )	$I_{FP}$			30 4	mA mA
Number of programming pulses	$n_{PP}$			50	pulses
Programming pulse	$t_{PPULSE}$	20		25	$\mu\text{s}$
Program to verify time	$t_{VPROG}$	10			$\mu\text{s}$
Program margin	$p_m$	100 <sup>(2)</sup>			%
Number of erase pulses	$n_{EP}$			5	pulses
Erase pulse	$t_{EPULSE}$	5		10	ms
Erase to verify time	$t_{VERASE}$	1			ms
Erase margin	$e_m$	100 <sup>(2)</sup>			%
Program/erase endurance		100			cycles
Data retention		10			years

1. Refer to errata for problem description and suggested workaround.
2. The number of margin pulses required is the same as the number of pulses used to program or erase.

## Table 75 Pulse Width Modulator Characteristics

$V_{DD} = 5.0 \text{ Vdc} \pm 5\%$ ,  $V_{SS} = 0 \text{ Vdc}$ ,  $T_A = T_L$  to  $T_H$ , unless otherwise noted

Characteristic	Symbol	Min	Max	Unit
E-clock frequency	$f_{\text{eclk}}$		10.0	MHz
A-clock frequency Selectable	$f_{\text{aclk}}$	$f_{\text{eclk}}/128$	$f_{\text{eclk}}$	Hz
B-clock frequency Selectable	$f_{\text{bclk}}$	$f_{\text{eclk}}/128$	$f_{\text{eclk}}$	Hz
Left-aligned PWM frequency 8-bit 16-bit	$f_{\text{lpwm}}$	$f_{\text{eclk}}/1\text{M}$ $f_{\text{eclk}}/256\text{M}$	$f_{\text{eclk}}/2$ $f_{\text{eclk}}/2$	Hz Hz
Left-aligned PWM resolution	$r_{\text{lpwm}}$	$f_{\text{eclk}}/4\text{K}$	$f_{\text{eclk}}$	Hz
Center-aligned PWM frequency 8-bit 16-bit	$f_{\text{cpwm}}$	$f_{\text{eclk}}/2\text{M}$ $f_{\text{eclk}}/512\text{M}$	$f_{\text{eclk}}$ $f_{\text{eclk}}$	Hz Hz
Center-aligned PWM resolution	$r_{\text{cpwm}}$	$f_{\text{eclk}}/4\text{K}$	$f_{\text{eclk}}$	Hz

Table 76 Control Timing

Characteristic	Symbol	10.0 MHz		Unit
		Min	Max	
Frequency of operation	$f_o$	dc	10.0	MHz
E-clock period	$t_{cyc}$	100	—	ns
Crystal frequency	$f_{XTAL}$	—	40.0	MHz
External oscillator frequency	$4f_o$	dc	40.0	MHz
Processor control setup time $t_{PCSU} = t_{cyc}/2 + 20$	$t_{PCSU}$	70	—	ns
Reset input pulse width To guarantee external reset vector Minimum input time (can be preempted by internal reset)	$PW_{RSTL}$	32 2	—	$t_{cyc}$ $t_{cyc}$
Mode programming setup time	$t_{MPS}$	4	—	$t_{cyc}$
Mode programming hold time	$t_{MPH}$	10	—	ns
Interrupt pulse width, $\overline{IRQ}$ edge-sensitive mode $PW_{IRQ} = 2t_{cyc} + 20$	$PW_{IRQ}$	220	—	ns
Wait recovery startup time $t_{WRS} = 4t_{cyc}$	$t_{WRS}$	—	TBD	$t_{cyc}$
Timer input capture pulse width $PW_{TIM} = 2t_{cyc} + 20$	$PW_{TIM}$	220	—	ns
Pulse accumulator pulse width	$PW_{PA}$	TBD	—	ns

1.  $\overline{RESET}$  is recognized during the first clock cycle it is held low. Internal circuitry then drives the pin low for 16 clock cycles, releases the pin, and samples the pin level 8 cycles later to determine the source of the interrupt.

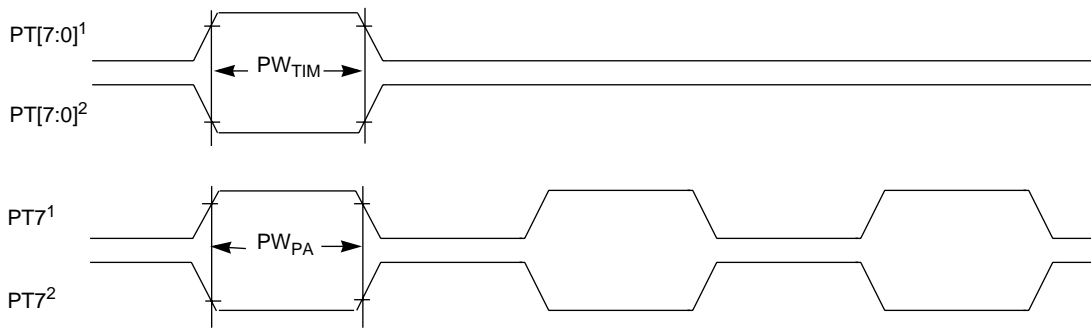

NOTES:  
1. Rising edge sensitive input  
2. Falling edge sensitive input

Figure 59 Timer Inputs

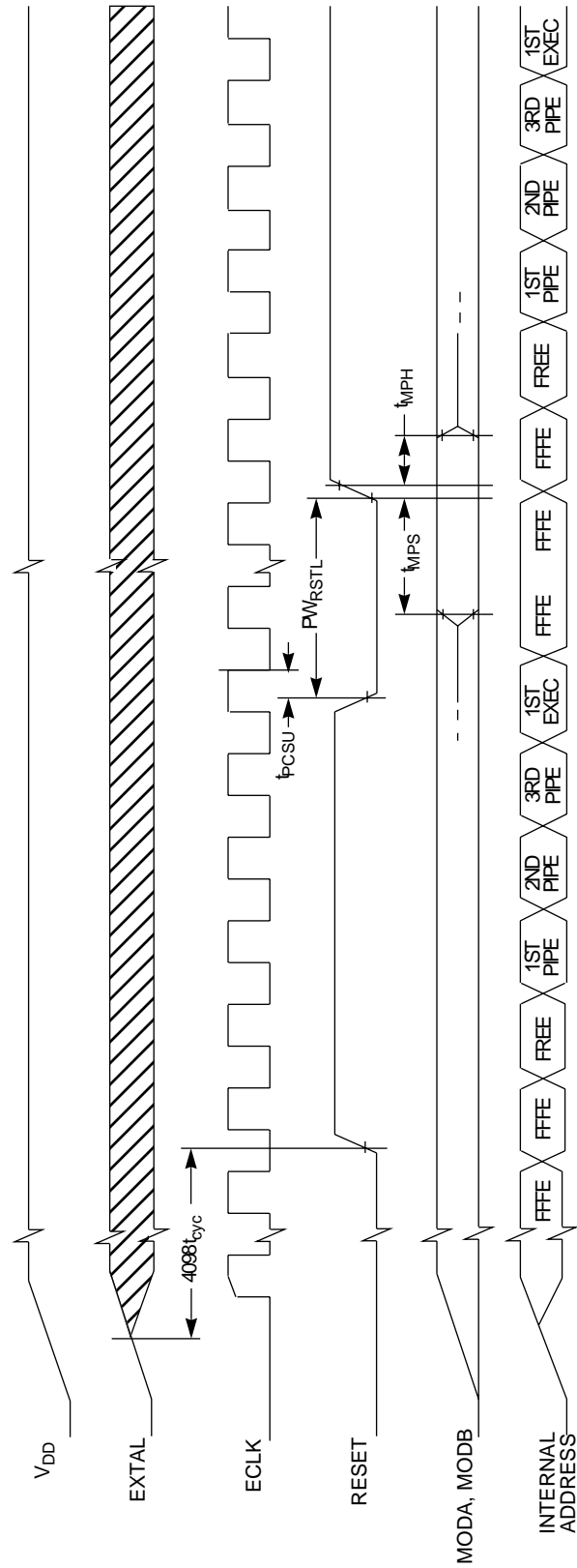

NOTE: Reset timing is subject to change.

**Figure 60 POR and External Reset Timing Diagram**

Preliminary Electrical Characteristics

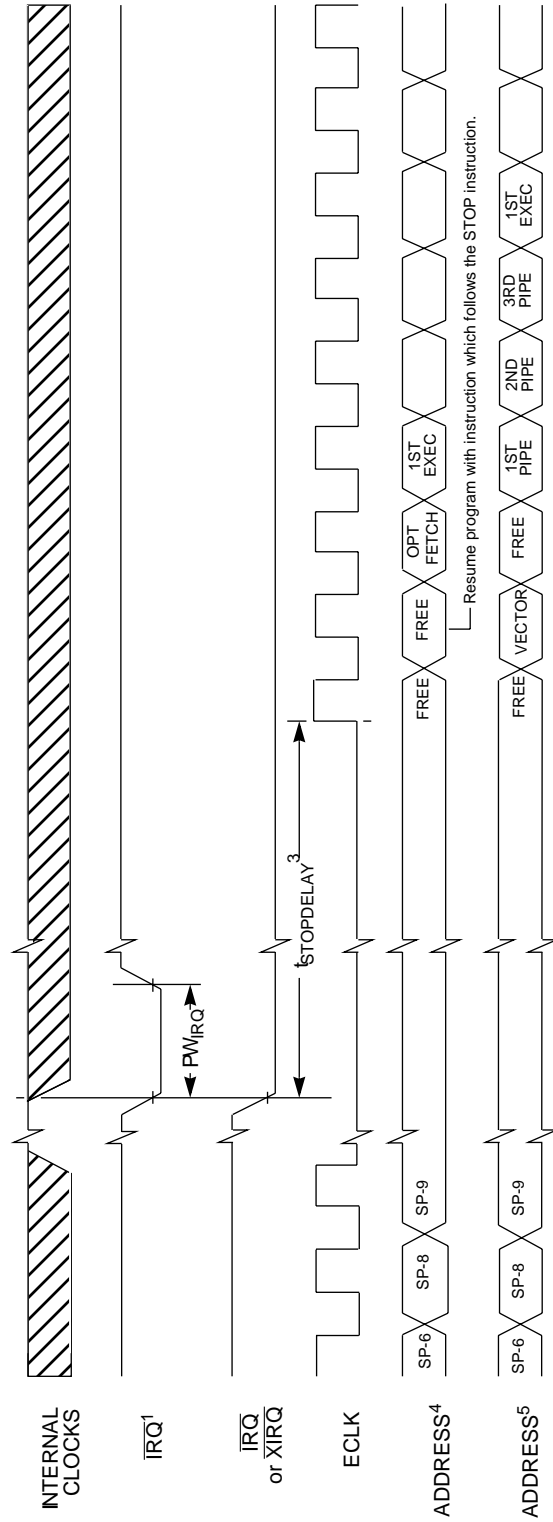

- NOTES:
1. Edge Sensitive IRQ pin (IRQE bit = 1)
  2. Level sensitive IRQ pin (IRQE bit = 0)
  3.  $t_{STOPDELAY} = 4098 t_{cyc}$  if DLY bit = 1 or  $2 t_{cyc}$  if DLY = 0.
  4. XIRQ with X bit in CCR = 1.
  5. IRQ or XIRQ with X bit in CCR = 0.

Figure 61 STOP Recovery Timing Diagram

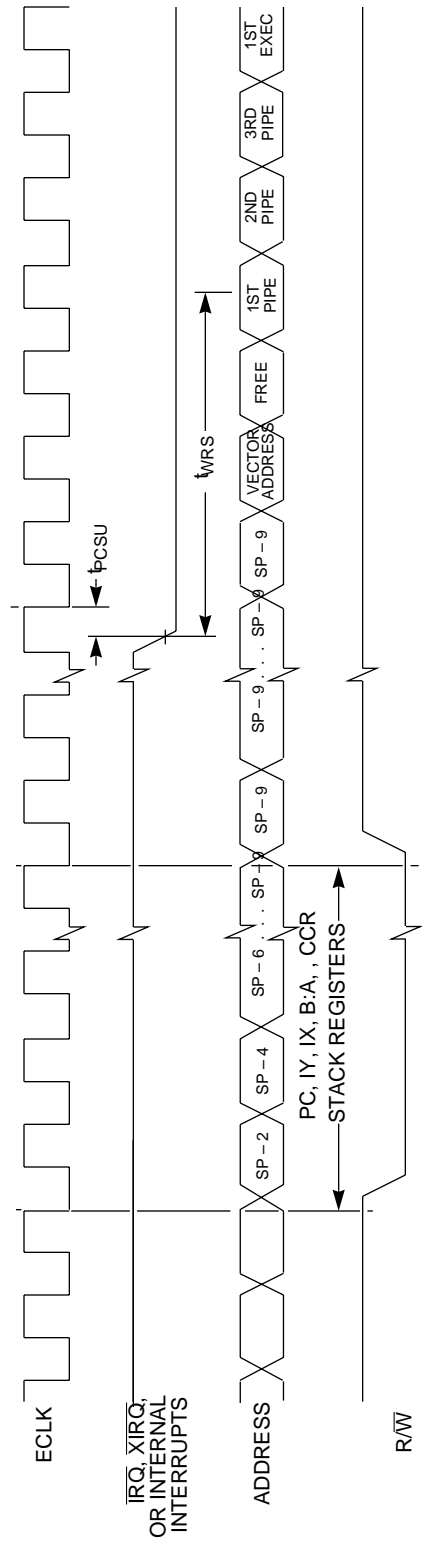

NOTE: RESET also causes recovery from WAIT.

**Figure 62 WAIT Recovery Timing Diagram**

Preliminary Electrical Characteristics

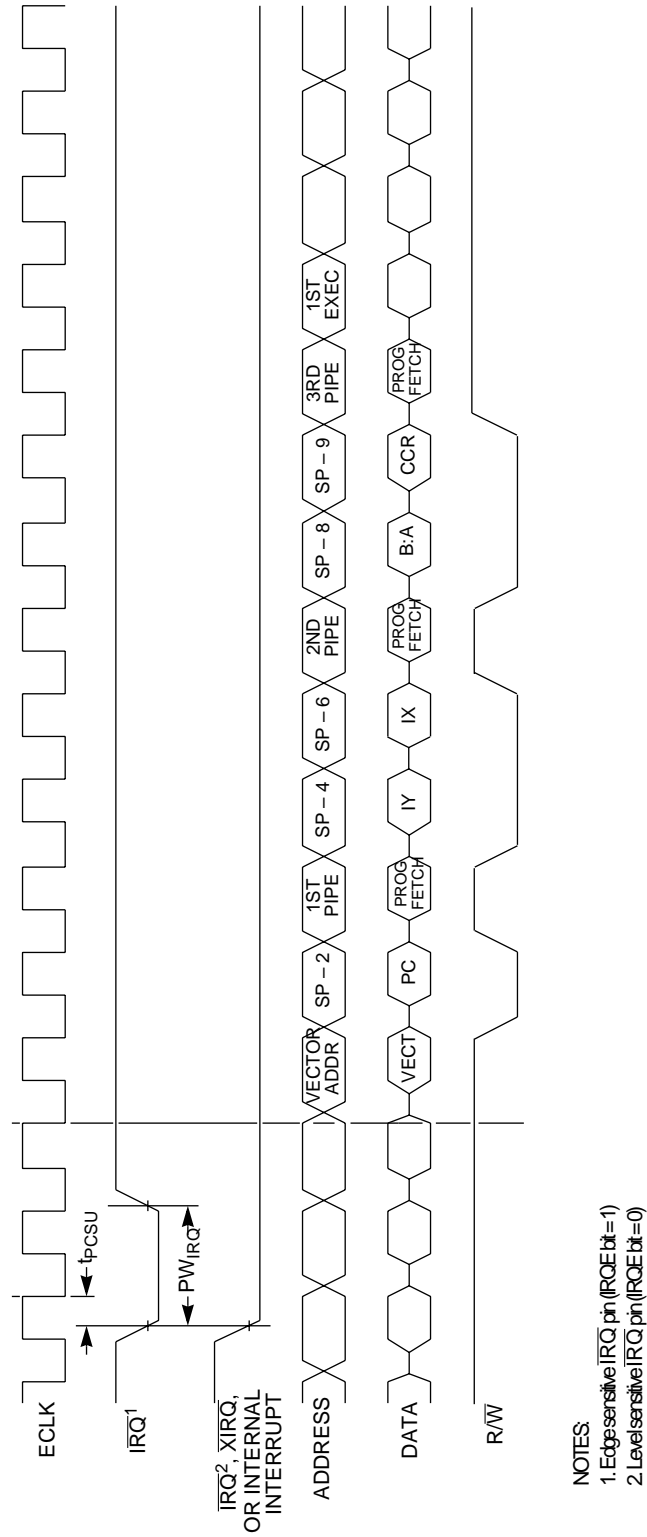

Figure 63 Interrupt Timing Diagram



Table 77 Peripheral Port Timing

Characteristic	Symbol	10.0 MHz		Unit
		Min	Max	
Frequency of operation (E-clock frequency)	$f_o$	dc	10.0	MHz
E-clock period	$t_{cyc}$	100	—	ns
Peripheral data setup time MCU read of ports $t_{PDSU} = t_{cyc}/2 + 40$	$t_{PDSU}$	90	—	ns
Peripheral data hold time MCU read of ports	$t_{PDH}$	0	—	ns
Delay time, peripheral data write MCU write to ports except Port SBI	$t_{PWD}$	—	40	ns
Delay time, peripheral data write MCU write to Port SBI	$t_{PWD}$	—	65	ns

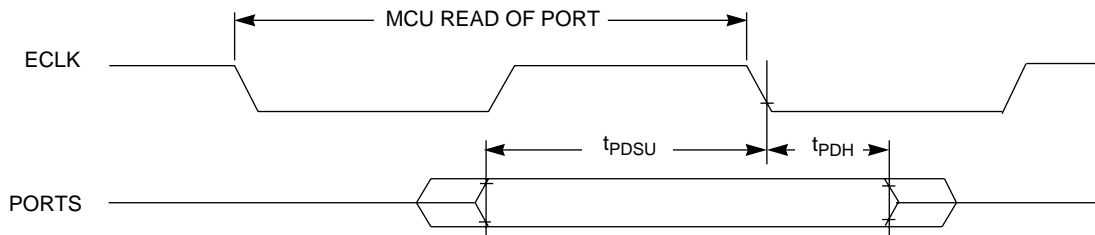

Figure 64 Port Read Timing Diagram

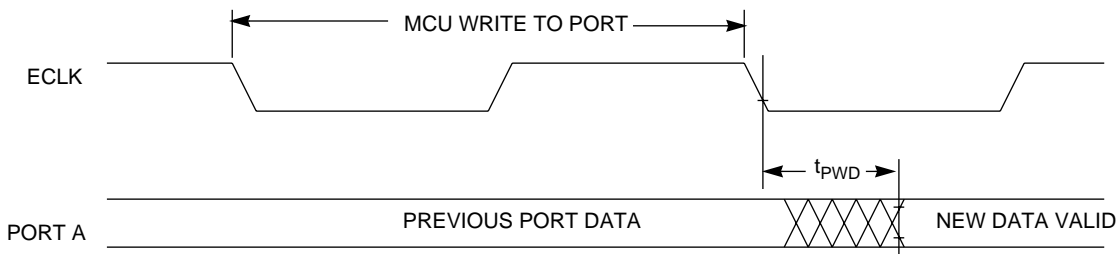

Figure 65 Port Write Timing Diagram

Preliminary Electrical Characteristics

**Table 78 Multiplexed Expansion Bus Timing**

$V_{DD} = 5.0 \text{ Vdc} \pm 5\%$ ,  $V_{SS} = 0 \text{ Vdc}$ ,  $T_A = T_L$  to  $T_H$ , unless otherwise noted

Num	Characteristic <sup>(1), (2), (3), (4)</sup>	Delay	Symbol	10 MHz		Unit
				Min	Max	
	Frequency of operation (E-clock frequency)		$f_o$	dc	10.0	MHz
1	Cycle time $t_{cyc} = 1/f_o$	—	$t_{cyc}$	100	—	ns
2	Pulse width, E low $PW_{EL} = t_{cyc}/2 + \text{delay}$	-2	$PW_{EL}$	48	—	ns
3	Pulse width, E high <sup>(5)</sup> $PW_{EH} = t_{cyc}/2 + \text{delay}$	-2	$PW_{EH}$	48	—	ns
5	Address delay time $t_{AD} = t_{cyc}/4 + \text{delay}$	29	$t_{AD}$	—	54	ns
7	Address valid time to ECLK rise $t_{AV} = PW_{EL} - t_{AD}$	—	$t_{AV}$	0	—	ns
8	Multiplexed address hold time $t_{MAH} = t_{cyc}/4 + \text{delay}$	-21	$t_{MAH}$	4	—	ns
9	Address Hold to Data Valid	—	$t_{AHDS}$	30	—	
10	Data Hold to High Z $t_{DHZ} = t_{AD} - 20$	—	$t_{DHZ}$	—	34	
11	Read data setup time	—	$t_{DSR}$	30	—	ns
12	Read data hold time	—	$t_{DHR}$	0	—	ns
13	Write data delay time	—	$t_{DDW}$	—	47	ns
14	Write data hold time	—	$t_{DHW}$	20	—	ns
15	Write data setup time <sup>(5)</sup> $t_{DSW} = PW_{EH} - t_{DDW}$	—	$t_{DSW}$	1	—	ns
16	Read/write delay time $t_{RWD} = t_{cyc}/4 + \text{delay}$	18	$t_{RWD}$	—	43	ns
17	Read/write valid time to E rise $t_{RWV} = PW_{EL} - t_{RWD}$	—	$t_{RWV}$	5	—	ns
18	Read/write hold time	—	$t_{RWH}$	20	—	ns
19	Low strobe <sup>(7)</sup> delay time $t_{LSD} = t_{cyc}/4 + \text{delay}$	18	$t_{LSD}$	—	43	ns
20	Low strobe <sup>(7)</sup> valid time to E rise $t_{LSV} = PW_{EL} - t_{LSD}$	—	$t_{LSV}$	5	—	ns
21	Low strobe <sup>(7)</sup> hold time	—	$t_{LSH}$	20	—	ns
22	Address access time <sup>(5)</sup> $t_{ACCA} = t_{cyc} - t_{AD} - t_{DSR}$	—	$t_{ACCA}$	—	16	ns
23	Access time from E rise <sup>(5)</sup> $t_{ACCE} = PW_{EH} - t_{DSR}$	—	$t_{ACCE}$	—	18	ns
24	$\overline{DBE}$ delay from ECLK rise <sup>(5)</sup> $t_{DBED} = t_{cyc}/4 + \text{delay}$	6	$t_{DBED}$	—	31	ns
25	$\overline{DBE}$ valid time $t_{DBE} = PW_{EH} - t_{DBED}$	—	$t_{DBE}$	17	—	ns
26	$\overline{DBE}$ hold time from ECLK fall	—	$t_{DBEH}$	0	10	ns

1. All timings are calculated for normal port drives.
2. Crystal input is required to be within 45% to 55% duty.
3. Reduced drive must be off to meet these timings.
4. Unequalled loading of pins will affect relative timing numbers.
5. This characteristic is affected by clock stretch.  
Add  $N \times t_{cyc}$  where  $N = 0, 1, 2, \text{ or } 3$ , depending on the number of clock stretches.
6. Equation still under evaluation
7. Without TAG enabled.

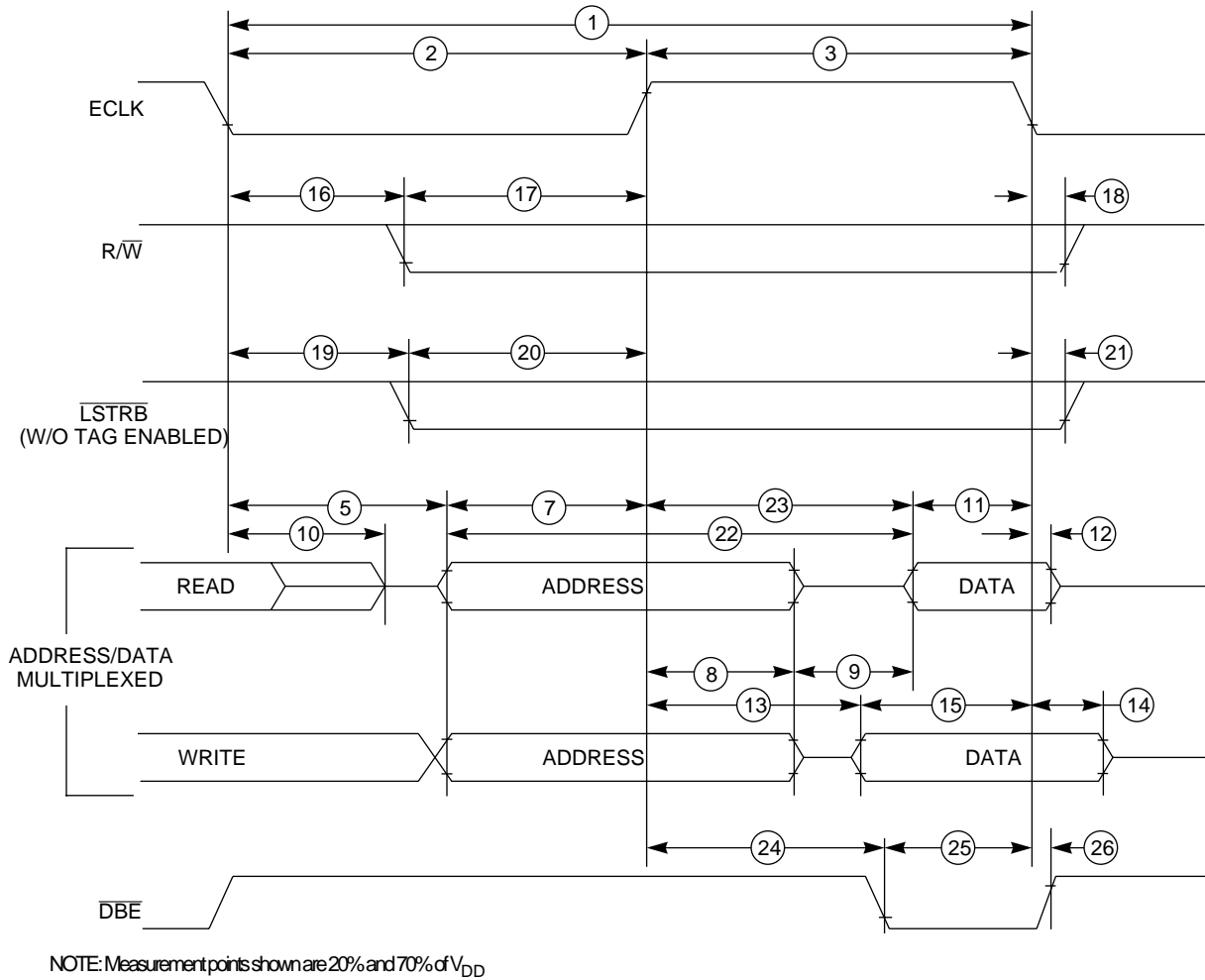

Figure 66 Multiplexed Expansion Bus Timing Diagram

Preliminary Electrical Characteristics

**Table 79 SPI Timing**

( $V_{DD} = 5.0 \text{ Vdc} \pm 5\%$ ,  $V_{SS} = 0 \text{ Vdc}$ ,  $T_A = T_L$  to  $T_H$ , 200 pF load on all SPI pins)<sup>(1)</sup>

Num	Function	Symbol	Min	Max	Unit
	Operating Frequency Master Slave	$f_{op}$	DC DC	1/2 1/2	E-clock frequency
	SCK Period Master Slave	$t_{sck}$	2 2	256 —	$t_{cyc}$ $t_{cyc}$
	Enable Lead Time Master Slave	$t_{lead}$	1/2 1	— —	$t_{sck}$ $t_{cyc}$
	Enable Lag Time Master Slave	$t_{lag}$	1/2 1	— —	$t_{sck}$ $t_{cyc}$
	Clock (SCK) High or Low Time Master Slave	$t_{wsck}$	$t_{cyc} - 60$ $t_{cyc} - 30$	$128 t_{cyc}$ —	ns ns
	Sequential Transfer Delay Master Slave	$t_{td}$	1/2 1	— —	$t_{sck}$ $t_{cyc}$
	Data Setup Time (Inputs) Master Slave	$t_{su}$	30 30	— —	ns ns
	Data Hold Time (Inputs) Master Slave	$t_{hi}$	0 30	— —	ns ns
	Slave Access Time	$t_a$	—	1	$t_{cyc}$
	Slave MISO Disable Time	$t_{dis}$	—	1	$t_{cyc}$
	Data Valid (after SCK Edge) Master Slave	$t_v$	— —	50 50	ns ns
	Data Hold Time (Outputs) Master Slave	$t_{ho}$	0 0	— —	ns ns
	Rise Time Input Output	$t_{ri}$ $t_{ro}$	— —	$t_{cyc} - 30$ 30	ns ns
	Fall Time Input Output	$t_{fi}$ $t_{fo}$	— —	$t_{cyc} - 30$ 30	ns ns

1. All AC timing is shown with respect to 20%  $V_{DD}$  and 70%  $V_{DD}$  levels unless otherwise noted.

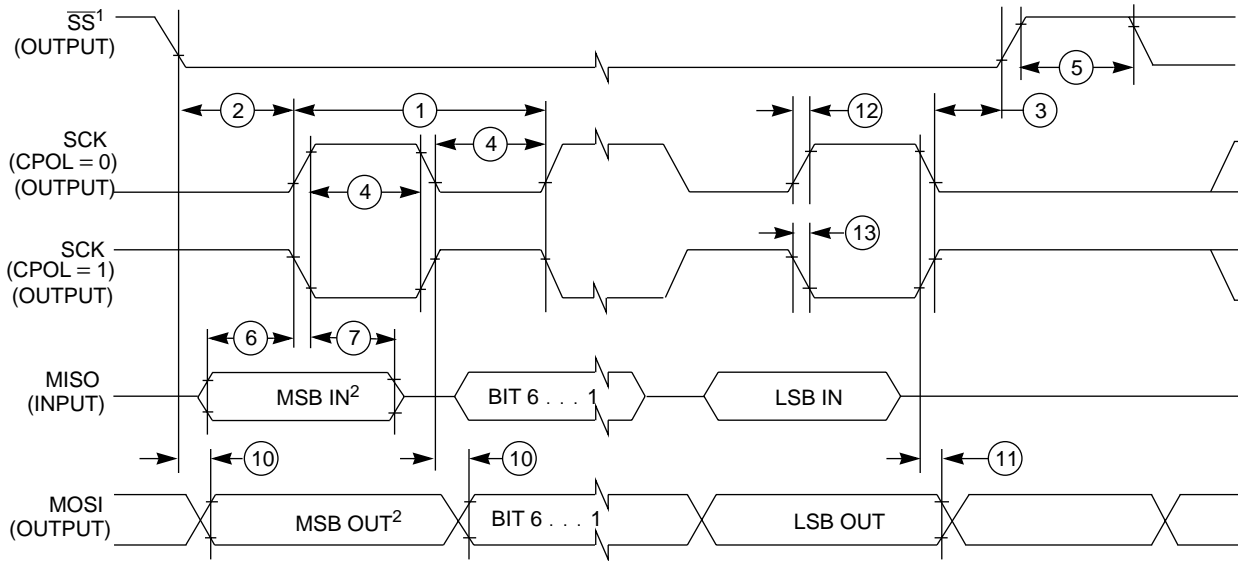

1.  $\overline{SS}$  output mode (DDS7 = 1, SSOE = 1).
2. LSBF = 0. For LSBF = 1, bit order is LSB, bit 1, ..., bit 6, MSB.

**A) SPI Master Timing (CPHA = 0)**

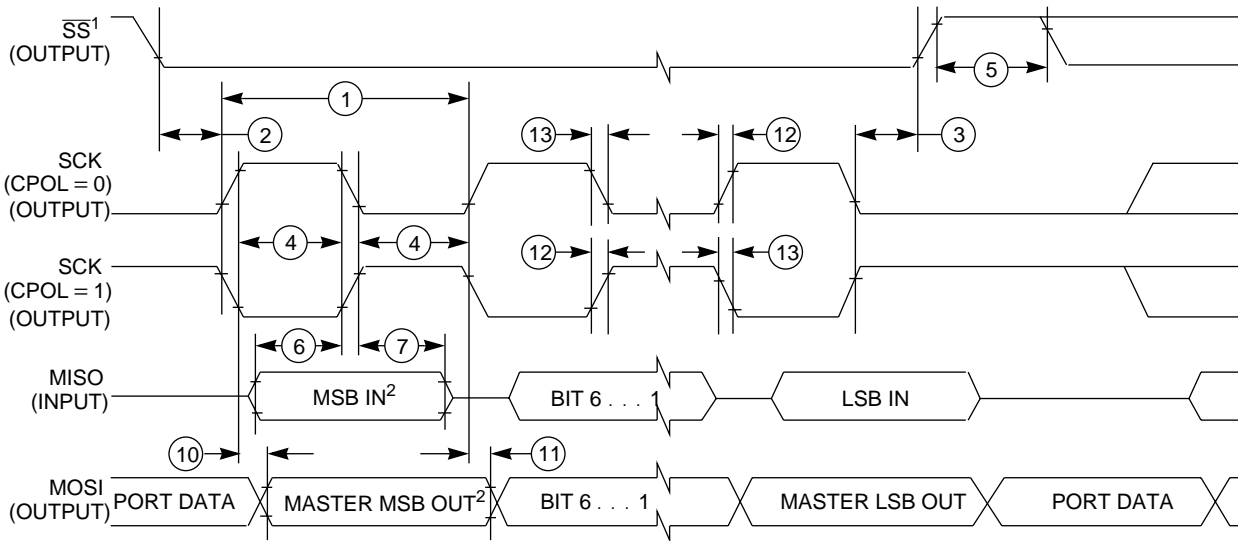

1.  $\overline{SS}$  output mode (DDS7 = 1, SSOE = 1).
2. LSBF = 0. For LSBF = 1, bit order is LSB, bit 1, ..., bit 6, MSB.

**B) SPI Master Timing (CPHA = 1)**

**Figure 67 SPI Timing Diagram (1 of 2)**

Preliminary Electrical Characteristics

Freescale Semiconductor, Inc.

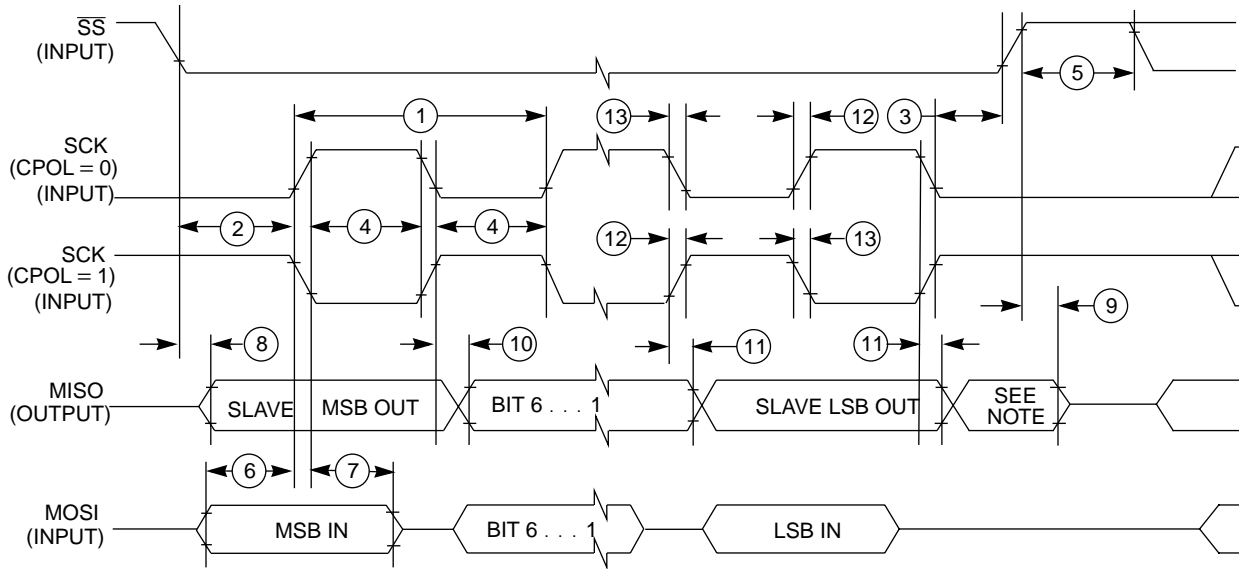

NOTE: Not defined but normally MSB of character just received.

**A) SPI Slave Timing (CPHA = 0)**

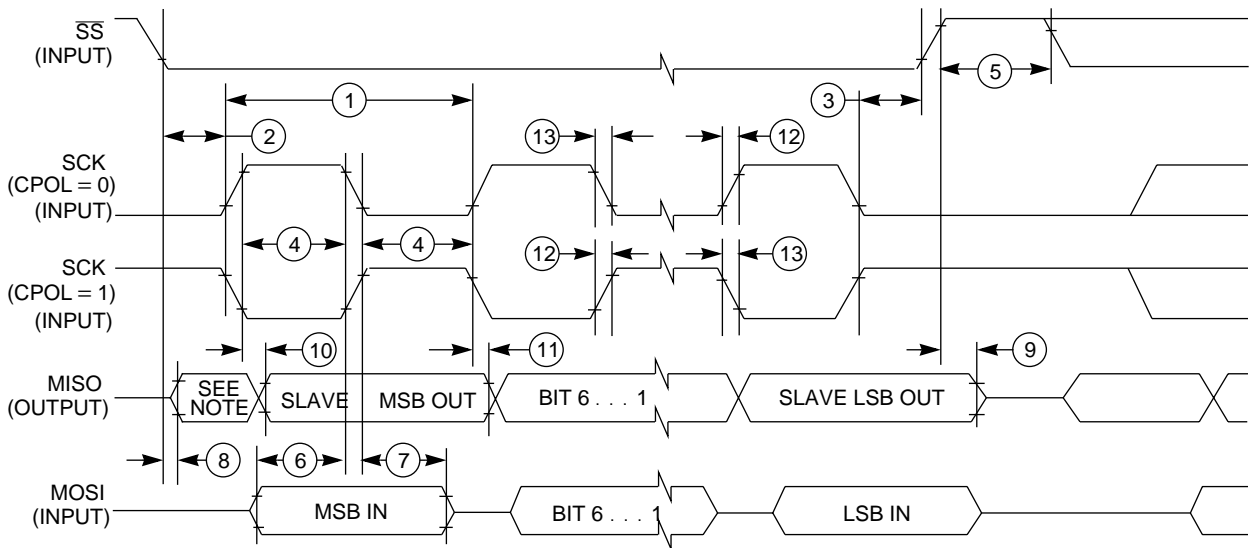

NOTE: Not defined but normally LSB of character just received.

**B) SPI Slave Timing (CPHA = 1)**

**Figure 68 SPI Timing Diagram (2 of 2)**

**Literature Updates**

This document contains the latest data available at publication time. For updates, contact one of the centers listed below:

---

---

**Literature Distribution Centers**

Order literature by mail or phone.

**USA/Europe**

Motorola Literature Distribution  
P.O. Box 5405  
Denver, Colorado, 80217  
Phone 1-303-675-2140

**Japan**

Motorola Japan Ltd.  
Tatsumi-SPD-JLDC  
Toshikatsu Otsuki  
6F Seibu-Butsuryu Center  
3-14-2 Tatsumi Koto-Ku  
Tokyo 135, Japan  
Phone 03-3521-8315

**Hong Kong**

Motorola Semiconductors H.K. Ltd.  
8B Tai Ping Industrial Park  
51 Ting Kok Road  
Tai Po, N.T., Hong Kong  
Phone 852-26629298

MC68HC912BD32 Rev 1.0

---

Literature Updates

**For More Information On This Product,  
Go to: [www.freescale.com](http://www.freescale.com)**

---

---

**Customer Focus Center**

1-800-521-6274

---

---

**Microcontroller Division's Web Site**

Directly access the Microcontroller Division's web site with the following URL:

<http://mcu.motsps.com/>



**A** — See “accumulators (A and B or D).”

**accumulators (A and B or D)** — Two 8-bit (A and B) or one 16-bit (D) general-purpose registers in the CPU. The CPU uses the accumulators to hold operands and results of arithmetic and logic operations.

**acquisition mode** — A mode of PLL operation with large loop bandwidth. Also see ‘tracking mode’.

**address bus** — The set of wires that the CPU uses to read and write memory locations.

**addressing mode** — The way that the CPU determines the operand address for an instruction. The M68HC12 CPU has 15 addressing modes.

**ALU** — See “arithmetic logic unit (ALU).”

**analogue-to-digital converter (ATD)** — The ATD module is an 8-channel, multiplexed-input successive-approximation analog-to-digital converter.

**arithmetic logic unit (ALU)** — The portion of the CPU that contains the logic circuitry to perform arithmetic, logic, and manipulation operations on operands.

**asynchronous** — Refers to logic circuits and operations that are not synchronized by a common reference signal.

**ATD** — See “analogue-to-digital converter”.

**B** — See “accumulators (A and B or D).”

**baud rate** — The total number of bits transmitted per unit of time.

**BCD** — See “binary-coded decimal (BCD).”

**binary** — Relating to the base 2 number system.

**binary number system** — The base 2 number system, having two digits, 0 and 1. Binary arithmetic is convenient in digital circuit design because digital circuits have two permissible voltage levels, low and high. The binary digits 0 and 1 can be interpreted to correspond to the two digital voltage levels.

**binary-coded decimal (BCD)** — A notation that uses 4-bit binary numbers to represent the 10 decimal digits and that retains the same positional structure of a decimal number. For example,

234 (decimal) = 0010 0011 0100 (BCD)

**bit** — A binary digit. A bit has a value of either logic 0 or logic 1.

**branch instruction** — An instruction that causes the CPU to continue processing at a memory location other than the next sequential address.

**break module** — The break module allows software to halt program execution at a programmable point in order to enter a background routine.

**breakpoint** — A number written into the break address registers of the break module. When a number appears on the internal address bus that is the same as the number in the break address registers, the CPU executes the software interrupt instruction (SWI).

**break interrupt** — A software interrupt caused by the appearance on the internal address bus of the same value that is written in the break address registers.

**bus** — A set of wires that transfers logic signals.

**bus clock** — See "CPU clock".

**byte** — A set of eight bits.

**CAN** — See "Motorola scalable CAN."

**CCR** — See "condition code register."

**central processor unit (CPU)** — The primary functioning unit of any computer system. The CPU controls the execution of instructions.

**CGM** — See "clock generator module (CGM)."

**clear** — To change a bit from logic 1 to logic 0; the opposite of set.

**clock** — A square wave signal used to synchronize events in a computer.

**clock generator module (CGM)** — The CGM module generates a base clock signal from which the system clocks are derived. The CGM may include a crystal oscillator circuit and/or phase-locked loop (PLL) circuit.

**comparator** — A device that compares the magnitude of two inputs. A digital comparator defines the equality or relative differences between two binary numbers.

**computer operating properly module (COP)** — A counter module that resets the MCU if allowed to overflow.

**condition code register (CCR)** — An 8-bit register in the CPU that contains the interrupt mask bit and five bits that indicate the results of the instruction just executed.

**control bit** — One bit of a register manipulated by software to control the operation of the module.

**control unit** — One of two major units of the CPU. The control unit contains logic functions that synchronize the machine and direct various operations. The control unit decodes instructions and generates the internal control signals that perform the requested operations. The outputs of the control unit drive the execution unit, which contains the arithmetic logic unit (ALU), CPU registers, and bus interface.

**COP** — See "computer operating properly module (COP)."

**CPU** — See "central processor unit (CPU)."

**CPU12** — The CPU of the MC68HC12 Family.

**CPU clock** — Bus clock select bits BCSP and BCSS in the clock select register (CLKSEL) determine which clock drives SYSCLK for the main system, including the CPU and buses. When EXTALi drives the SYSCLK, the CPU or bus clock frequency ( $f_0$ ) is equal to the EXTALi frequency divided by 2.

**CPU cycles** — A CPU cycle is one period of the internal bus clock, normally derived by dividing a crystal oscillator source by two or more so the high and low times will be equal. The length of time required to execute an instruction is measured in CPU clock cycles.

**CPU registers** — Memory locations that are wired directly into the CPU logic instead of being part of the addressable memory map. The CPU always has direct access to the information in these registers. The CPU registers in an M68HC12 are:

- A (8-bit accumulator)
- B (8-bit accumulator)
  - D (16-bit accumulator formed by concatenation of accumulators A and B)
- IX (16-bit index register)
- IY (16-bit index register)
- SP (16-bit stack pointer)
- PC (16-bit program counter)
- CCR (8-bit condition code register)

**cycle time** — The period of the operating frequency:  $t_{CYC} = 1/f_{OP}$ .

**D** — See “accumulators (A and B or D).”

**decimal number system** — Base 10 numbering system that uses the digits zero through nine.

**duty cycle** — A ratio of the amount of time the signal is on versus the time it is off. Duty cycle is usually represented by a percentage.

**ECT** — See “enhanced capture timer.”

**EEPROM** — Electrically erasable, programmable, read-only memory. A nonvolatile type of memory that can be electrically erased and reprogrammed.

**EPROM** — Erasable, programmable, read-only memory. A nonvolatile type of memory that can be erased by exposure to an ultraviolet light source and then reprogrammed.

**enhanced capture timer (ECT)** — The HC12 Enhanced Capture Timer module has the features of the HC12 Standard Timer module enhanced by additional features in order to enlarge the field of applications.

**exception** — An event such as an interrupt or a reset that stops the sequential execution of the instructions in the main program.

**fetch** — To copy data from a memory location into the accumulator.

**firmware** — Instructions and data programmed into nonvolatile memory.

**flash EEPROM** — Electrically erasable, programmable, read-only memory. A nonvolatile type of memory that can be electrically erased and reprogrammed. Does not support byte or word erase.

**free-running counter** — A device that counts from zero to a predetermined number, then rolls over to zero and begins counting again.

**full-duplex transmission** — Communication on a channel in which data can be sent and received simultaneously.

**hexadecimal** — Base 16 numbering system that uses the digits 0 through 9 and the letters A through F.

**high byte** — The most significant eight bits of a word.

**illegal address** — An address not within the memory map

**illegal opcode** — A nonexistent opcode.

- index registers (IX and IY)** — Two 16-bit registers in the CPU. In the indexed addressing modes, the CPU uses the contents of IX or IY to determine the effective address of the operand. IX and IY can also serve as a temporary data storage locations.
- input/output (I/O)** — Input/output interfaces between a computer system and the external world. A CPU reads an input to sense the level of an external signal and writes to an output to change the level on an external signal.
- instructions** — Operations that a CPU can perform. Instructions are expressed by programmers as assembly language mnemonics. A CPU interprets an opcode and its associated operand(s) and instruction.
- interrupt** — A temporary break in the sequential execution of a program to respond to signals from peripheral devices by executing a subroutine.
- interrupt request** — A signal from a peripheral to the CPU intended to cause the CPU to execute a subroutine.
- I/O** — See “input/output (I/O).”
- jitter** — Short-term signal instability.
- latch** — A circuit that retains the voltage level (logic 1 or logic 0) written to it for as long as power is applied to the circuit.
- latency** — The time lag between instruction completion and data movement.
- least significant bit (LSB)** — The rightmost digit of a binary number.
- logic 1** — A voltage level approximately equal to the input power voltage ( $V_{DD}$ ).
- logic 0** — A voltage level approximately equal to the ground voltage ( $V_{SS}$ ).
- low byte** — The least significant eight bits of a word.
- M68HC12** — A Motorola family of 16-bit MCUs.
- mark/space** — The logic 1/logic 0 convention used in formatting data in serial communication.
- mask** — 1. A logic circuit that forces a bit or group of bits to a desired state. 2. A photomask used in integrated circuit fabrication to transfer an image onto silicon.
- MCU** — Microcontroller unit. See “microcontroller.”

**memory location** — Each M68HC12 memory location holds one byte of data and has a unique address. To store information in a memory location, the CPU places the address of the location on the address bus, the data information on the data bus, and asserts the write signal. To read information from a memory location, the CPU places the address of the location on the address bus and asserts the read signal. In response to the read signal, the selected memory location places its data onto the data bus.

**memory map** — A pictorial representation of all memory locations in a computer system.

**MI-Bus** — See "Motorola interconnect bus".

**microcontroller** — Microcontroller unit (MCU). A complete computer system, including a CPU, memory, a clock oscillator, and input/output (I/O) on a single integrated circuit.

**modulo counter** — A counter that can be programmed to count to any number from zero to its maximum possible modulus.

**most significant bit (MSB)** — The leftmost digit of a binary number.

**Motorola interconnect bus (MI-Bus)** — The Motorola Interconnect Bus (MI Bus) is a serial communications protocol which supports distributed real-time control efficiently and with a high degree of noise immunity.

**Motorola scalable CAN (msCAN)** — The Motorola scalable controller area network is a serial communications protocol that efficiently supports distributed real-time control with a very high level of data integrity.

**msCAN** — See "Motorola scalable CAN".

**MSI** — See "multiple serial interface".

**multiple serial interface** — A module consisting of multiple independent serial I/O sub-systems, e.g. two SCI and one SPI.

**multiplexer** — A device that can select one of a number of inputs and pass the logic level of that input on to the output.

**nibble** — A set of four bits (half of a byte).

**object code** — The output from an assembler or compiler that is itself executable machine code, or is suitable for processing to produce executable machine code.

**opcode** — A binary code that instructs the CPU to perform an operation.

**open-drain** — An output that has no pullup transistor. An external pullup device can be connected to the power supply to provide the logic 1 output voltage.

**operand** — Data on which an operation is performed. Usually a statement consists of an operator and an operand. For example, the operator may be an add instruction, and the operand may be the quantity to be added.

**oscillator** — A circuit that produces a constant frequency square wave that is used by the computer as a timing and sequencing reference.

**OTPROM** — One-time programmable read-only memory. A nonvolatile type of memory that cannot be reprogrammed.

**overflow** — A quantity that is too large to be contained in one byte or one word.

**page zero** — The first 256 bytes of memory (addresses \$0000–\$00FF).

**parity** — An error-checking scheme that counts the number of logic 1s in each byte transmitted. In a system that uses odd parity, every byte is expected to have an odd number of logic 1s. In an even parity system, every byte should have an even number of logic 1s. In the transmitter, a parity generator appends an extra bit to each byte to make the number of logic 1s odd for odd parity or even for even parity. A parity checker in the receiver counts the number of logic 1s in each byte. The parity checker generates an error signal if it finds a byte with an incorrect number of logic 1s.

**PC** — See “program counter (PC).”

**peripheral** — A circuit not under direct CPU control.

**phase-locked loop (PLL)** — A clock generator circuit in which a voltage controlled oscillator produces an oscillation which is synchronized to a reference signal.

**PLL** — See “phase-locked loop (PLL).”

**pointer** — Pointer register. An index register is sometimes called a pointer register because its contents are used in the calculation of the address of an operand, and therefore points to the operand.

**polarity** — The two opposite logic levels, logic 1 and logic 0, which correspond to two different voltage levels,  $V_{DD}$  and  $V_{SS}$ .

**polling** — Periodically reading a status bit to monitor the condition of a peripheral device.

**port** — A set of wires for communicating with off-chip devices.

**prescaler** — A circuit that generates an output signal related to the input signal by a fractional scale factor such as 1/2, 1/8, 1/10 etc.

**program** — A set of computer instructions that cause a computer to perform a desired operation or operations.

**program counter (PC)** — A 16-bit register in the CPU. The PC register holds the address of the next instruction or operand that the CPU will use.

**pull** — An instruction that copies into the accumulator the contents of a stack RAM location. The stack RAM address is in the stack pointer.

**pullup** — A transistor in the output of a logic gate that connects the output to the logic 1 voltage of the power supply.

**pulse-width** — The amount of time a signal is on as opposed to being in its off state.

**pulse-width modulation (PWM)** — Controlled variation (modulation) of the pulse width of a signal with a constant frequency.

**push** — An instruction that copies the contents of the accumulator to the stack RAM. The stack RAM address is in the stack pointer.

**PWM period** — The time required for one complete cycle of a PWM waveform.

**RAM** — Random access memory. All RAM locations can be read or written by the CPU. The contents of a RAM memory location remain valid until the CPU writes a different value or until power is turned off.

**RC circuit** — A circuit consisting of capacitors and resistors having a defined time constant.

**read** — To copy the contents of a memory location to the accumulator.

**register** — A circuit that stores a group of bits.

**reserved memory location** — A memory location that is used only in special factory test modes. Writing to a reserved location has no effect. Reading a reserved location returns an unpredictable value.

**reset** — To force a device to a known condition.

**ROM** — Read-only memory. A type of memory that can be read but cannot be changed (written). The contents of ROM must be specified before manufacturing the MCU.

**SCI** — See "serial communication interface module (SCI)."

**serial** — Pertaining to sequential transmission over a single line.

**serial communications interface module (SCI)** — A module that supports asynchronous communication.

**serial peripheral interface module (SPI)** — A module that supports synchronous communication.

**set** — To change a bit from logic 0 to logic 1; opposite of clear.



**shift register** — A chain of circuits that can retain the logic levels (logic 1 or logic 0) written to them and that can shift the logic levels to the right or left through adjacent circuits in the chain.

**signed** — A binary number notation that accommodates both positive and negative numbers. The most significant bit is used to indicate whether the number is positive or negative, normally logic 0 for positive and logic 1 for negative. The other seven bits indicate the magnitude of the number.

**software** — Instructions and data that control the operation of a microcontroller.

**software interrupt (SWI)** — An instruction that causes an interrupt and its associated vector fetch.

**SPI** — See "serial peripheral interface module (SPI)."

**stack** — A portion of RAM reserved for storage of CPU register contents and subroutine return addresses.

**stack pointer (SP)** — A 16-bit register in the CPU containing the address of the next available storage location on the stack.

**start bit** — A bit that signals the beginning of an asynchronous serial transmission.

**status bit** — A register bit that indicates the condition of a device.

**stop bit** — A bit that signals the end of an asynchronous serial transmission.

**subroutine** — A sequence of instructions to be used more than once in the course of a program. The last instruction in a subroutine is a return from subroutine (RTS) instruction. At each place in the main program where the subroutine instructions are needed, a jump or branch to subroutine (JSR or BSR) instruction is used to call the subroutine. The CPU leaves the flow of the main program to execute the instructions in the subroutine. When the RTS instruction is executed, the CPU returns to the main program where it left off.

**synchronous** — Refers to logic circuits and operations that are synchronized by a common reference signal.

**timer** — A module used to relate events in a system to a point in time.

**toggle** — To change the state of an output from a logic 0 to a logic 1 or from a logic 1 to a logic 0.

**tracking mode** — A mode of PLL operation with narrow loop bandwidth. Also see 'acquisition mode.'

**two's complement** — A means of performing binary subtraction using addition techniques. The most significant bit of a two's complement number indicates the sign of the number (1 indicates negative). The two's complement negative of a number is obtained by inverting each bit in the number and then adding 1 to the result.

**unbuffered** — Utilizes only one register for data; new data overwrites current data.

**unimplemented memory location** — A memory location that is not used. Writing to an unimplemented location has no effect. Reading an unimplemented location returns an unpredictable value.

**variable** — A value that changes during the course of program execution.

**VCO** — See "voltage-controlled oscillator."

**vector** — A memory location that contains the address of the beginning of a subroutine written to service an interrupt or reset.

**voltage-controlled oscillator (VCO)** — A circuit that produces an oscillating output signal of a frequency that is controlled by a dc voltage applied to a control input.

**waveform** — A graphical representation in which the amplitude of a wave is plotted against time.

**wired-OR** — Connection of circuit outputs so that if any output is high, the connection point is high.

**word** — A set of two bytes (16 bits).

**write** — The transfer of a byte of data from the CPU to a memory location.

**Freescale Semiconductor, Inc.**

**Freescale Semiconductor, Inc.**

**For More Information On This Product,  
Go to: [www.freescale.com](http://www.freescale.com)**

---

MC68HC08AZ60/D

**For More Information On This Product,  
Go to: [www.freescale.com](http://www.freescale.com)**