

Features

- Low-Voltage Operation: Down to 1.24V
- 1% Reference-Voltage Tolerance
- Adjustable Output Voltage, $V_o = V_{ref}$ to 12V
- Low Operational Cathode Current... $50 \mu A$
- 0.25Ω Typical Output Impedance
- SOT-23 and TO-92 Packages

Application

- Linear Regulators
- Voltage Reference for Power Circuit

Description

The AT431 is low-voltage three-terminal adjustable voltage reference with specified thermal stability over applicable commercial temperature ranges. Output voltage may be set to any value between V_{ref} (1.24V) and 12V with two external resistors (see Figure 2).

When used with an optocoupler, the AT431 is ideal voltage reference in isolated feedback circuits for 1.8V to 12 V switching-mode power supplies. This device has typical output impedance of 0.20Ω . Active output circuitry provides a very sharp turn-on characteristic, making the AT431 excellent replacements for low-voltage zener diodes in many applications, including onboard regulation and adjustable power supplies.

Block Diagram and Symbol

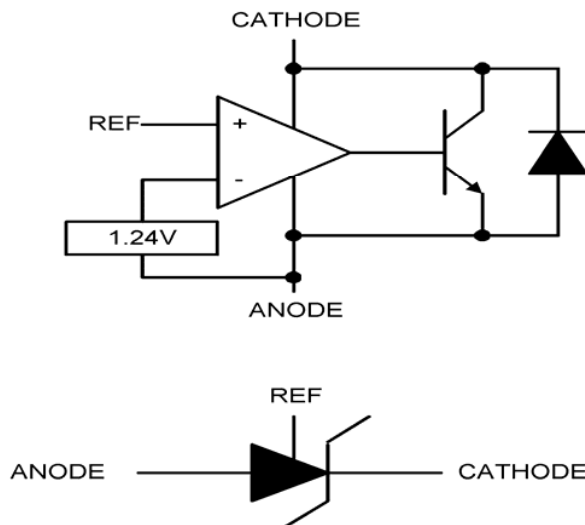

Aimtron reserves the right without notice to change this circuitry and specifications.

Equivalent Schematic

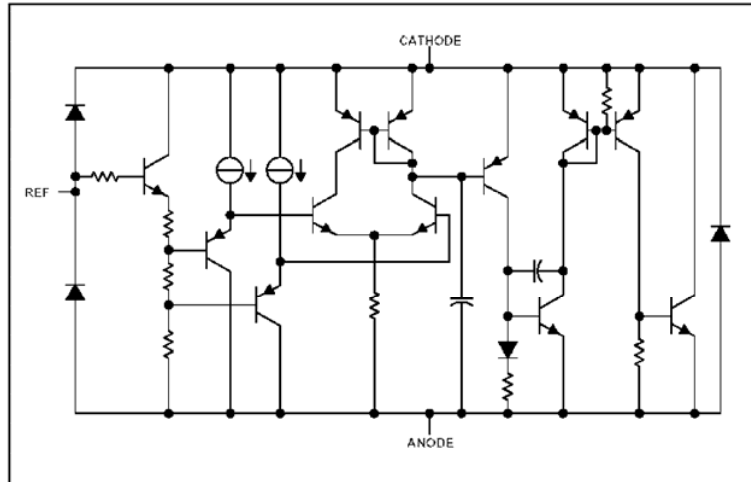

Pin Assignments

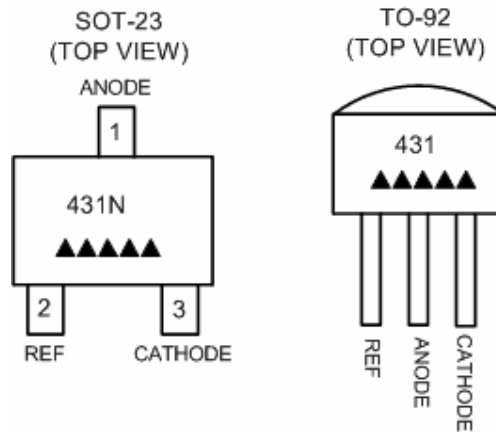

Ordering Information

Part number	Package	Marking
AT431Z	TO-92	▲▲▲▲▲ Date Code
AT431UN	SOT-23	▲▲▲▲▲ Date Code
AT431UN_GRE	SOT-23, Green	▲▲▲▲▲, Date Code with one bottom line

▲▲▲▲▲ : Date Code

**For more marking information, contact our sales representative directly*

Absolute maximum ratings (T_A = 25°C)

Parameter	Symbol	Limits	unit
Cathode voltage	V _{KA}	12	V
Continuous cathode current range	I _K	-20~20	mA
Reference Current	I _{REF}	-0.05~3	mA
Operating temperature	T _{OPR}	-30~+85	°C
Storage temperature	T _{STG}	-55~+150	°C
Package thermal impedance θ _{JA}	SOT-23-5	347	°C / W
	SOT-23-3		
	TO-92	156	
Power Dissipation	PD	(T _{J(max)} -T _A) / θ _{JA}	

Stresses beyond those listed under "absolute maximum ratings" may cause permanent damage to the device. Exposure to absolute-maximum-rated conditions for extended periods may affect device reliability.

Recommend operating condtion

Parameter	min	Max	unit
Cathode voltage V _{KA}	V _{ref}	12	V
Continuous cathode current range I _K	0.05	15	mA
Operating free-air temperature range T _A	0	70	°C

Electrical characteristics (unless otherwise noted)

Parameter	Symbol	Min.	Typ.	Max.	Unit	Conditions
Reference Voltage	V _{ref} (T _A = 25°C)	1.228	1.24	1.252	V	V _{KA} = V _{ref}
	V _{ref} (T _A = full range 0~70 °C)	1.221	-	1.259	V	I _K = 10mA (Figure 1)
V _{ref} deviation over full temperature range	V _{ref} (dev)	-	4	20	mV	V _{KA} = V _{ref} I _K = 10mA (Figure 1)
Ratio of V _{ref} change in cathode voltage change	Δ V _{ref} / Δ V _{KA}	-	-1.5	-2.7	mV/V	V _{KA} = V _{ref} to 12V I _K = 10mA (Figure 2)
Reference terminal current	I _{ref}	-	0.15	0.5	μA	I _K = 10mA R1 = 10KΩ (Figure 2)
I _{ref} deviation over full temperature range	I _{ref} (dev)	-	0.05	0.3	μA	I _K = 10mA R1 = 10KΩ R2 = open (Figure 2)
Minimum cathode current for regulation	I _K (min)	-	40	50	μA	V _{KA} = V _{ref} (Figure 1)
Off-state cathode current	I _K (off)	-	0.001	0.1	μA	V _{KA} = 12V V _{ref} = 0V (Figure 3)
Dynamic impedance	Z _{KA}	-	0.20	0.4	Ω	V _{KA} = V _{ref} f ≤ 1KHz I _K = 0.1mA to 15mA (Figure 1)

* The dynamic impedance is defined as : |Z_{KA}| = Δ V_{KA} / Δ I_{KA}

Parameter Measurement Information

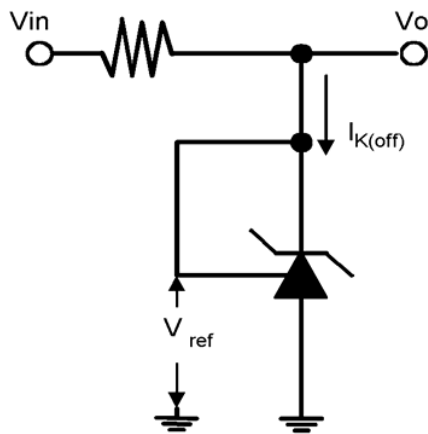

Figure 1. Test Circuit for $V_{KA}=V_{ref}$
 $V_O = V_{KA} = V_{ref}$

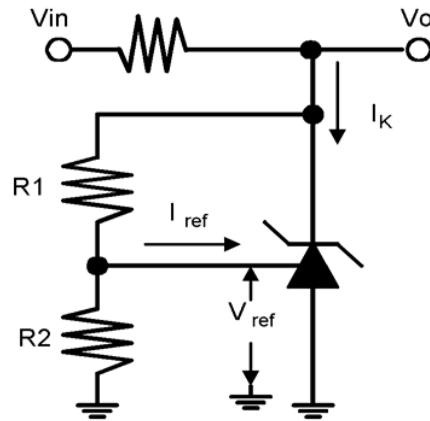

Figure 2. Test Circuit for $V_{KA} > V_{ref}$
 $V_O = V_{KA} = V_{ref} * (1 + R1/R2) + I_{ref} * R1$

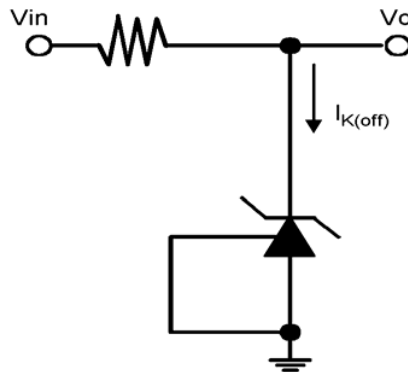

Figure 3. Test Circuit for $I_{K(off)}$

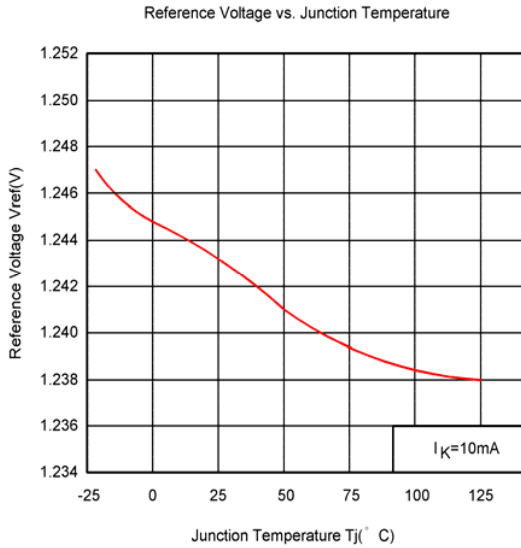

Figure 4.

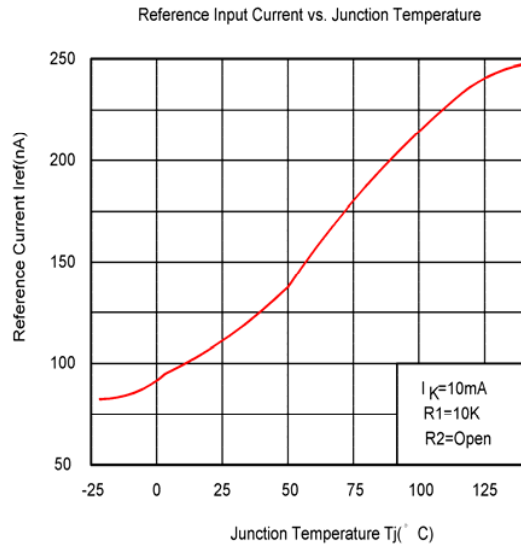

Figure 5.

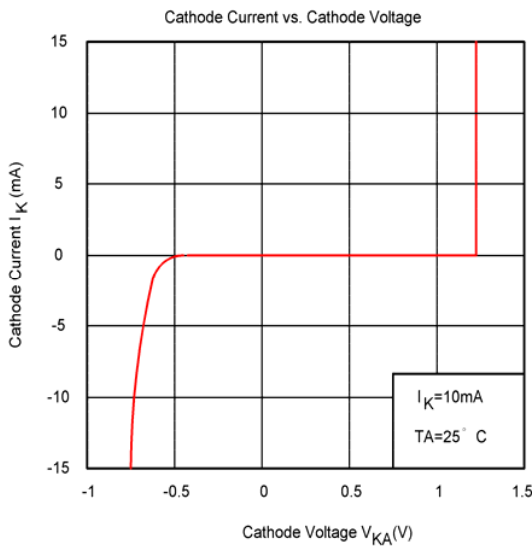

Figure 6.

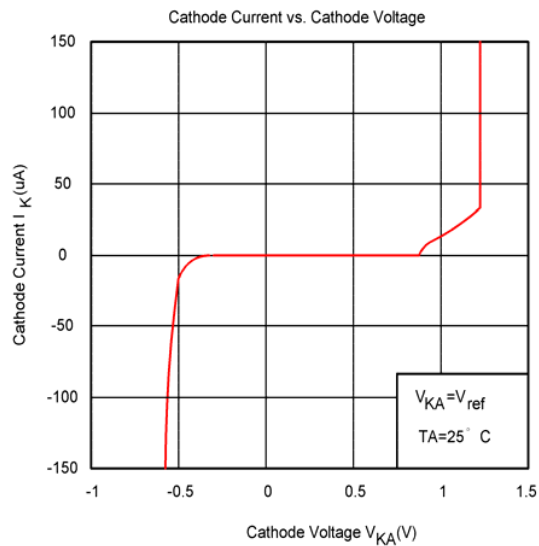

Figure 7.

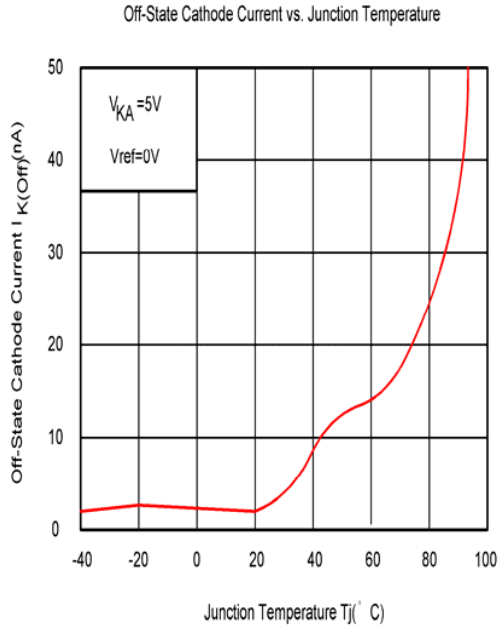

Figure 8.

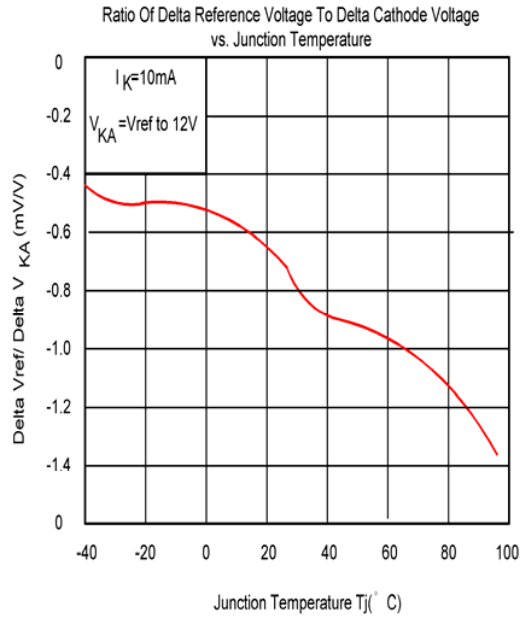

Figure 9.

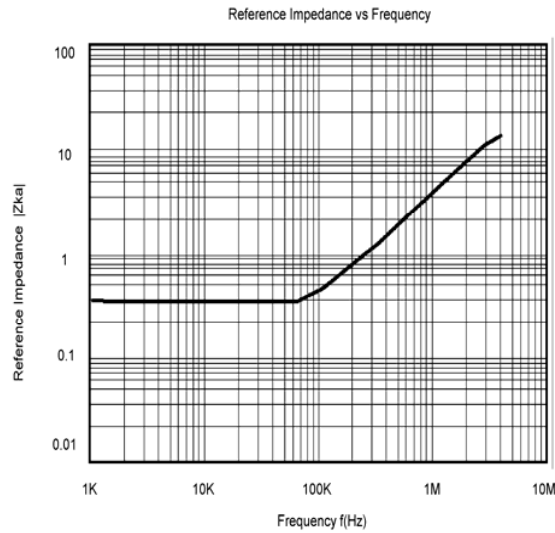
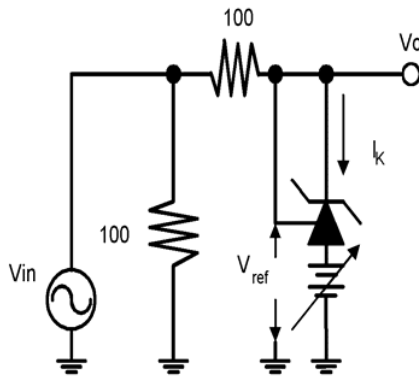
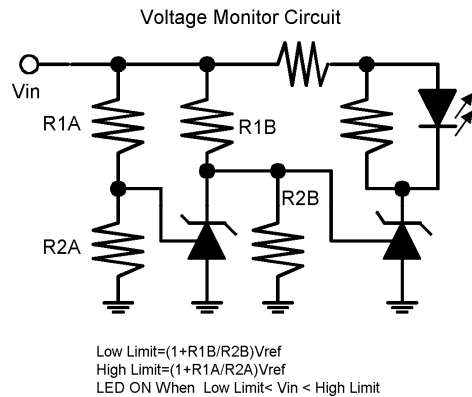
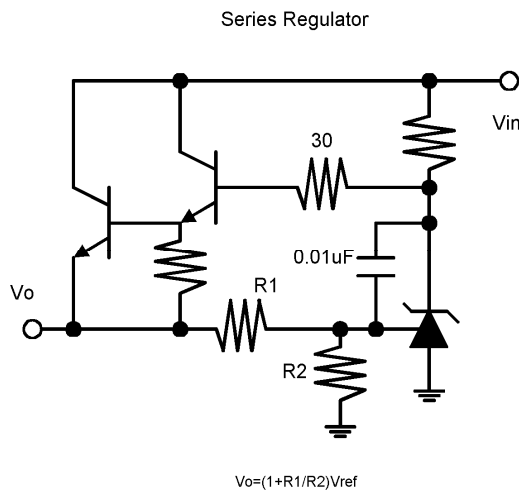
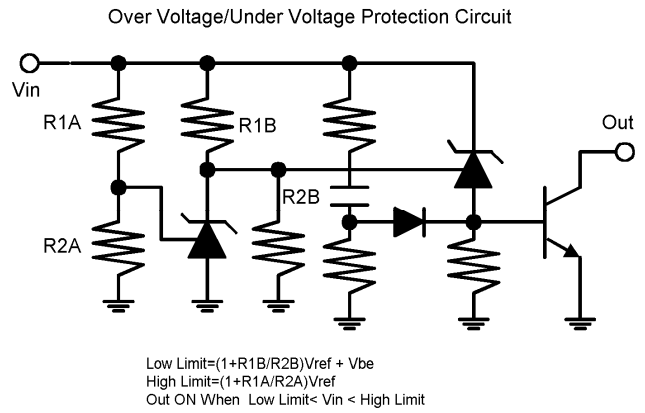
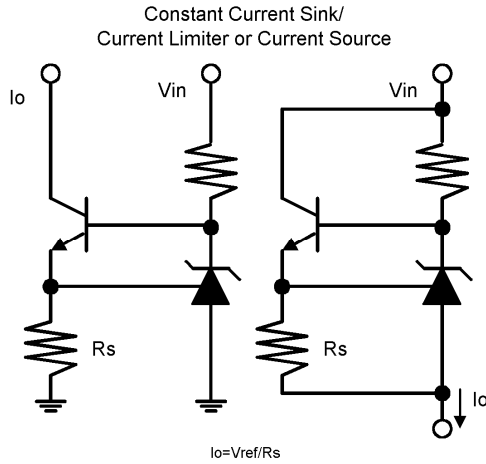
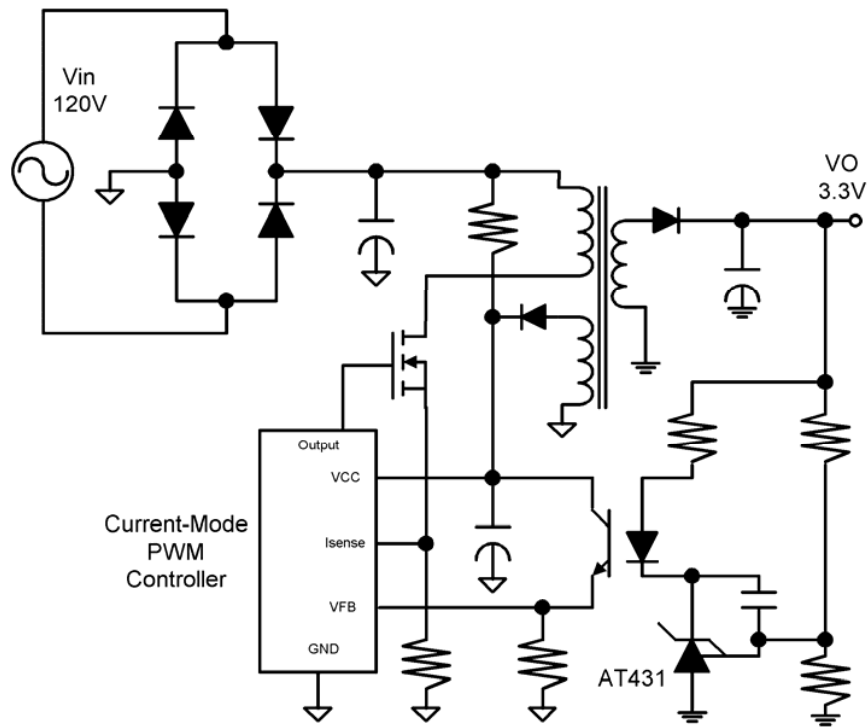

Figure 10.

Application Circuit





Above shows the AT431 used in a 3.3V isolated flyback supply. Output voltage V_o can be as low as reference voltage V_{ref} ($1.24V \pm 1\%$). The output of the regulator, plus the forward voltage drop of the optocoupler LED ($1.24 + 1.4 = 2.64V$), determine the minimum voltage that can be regulated in an isolated in an isolated supply configuration. Regulated voltage as low as 2.7V is possible using the circuit.

Package Information

SOT-23

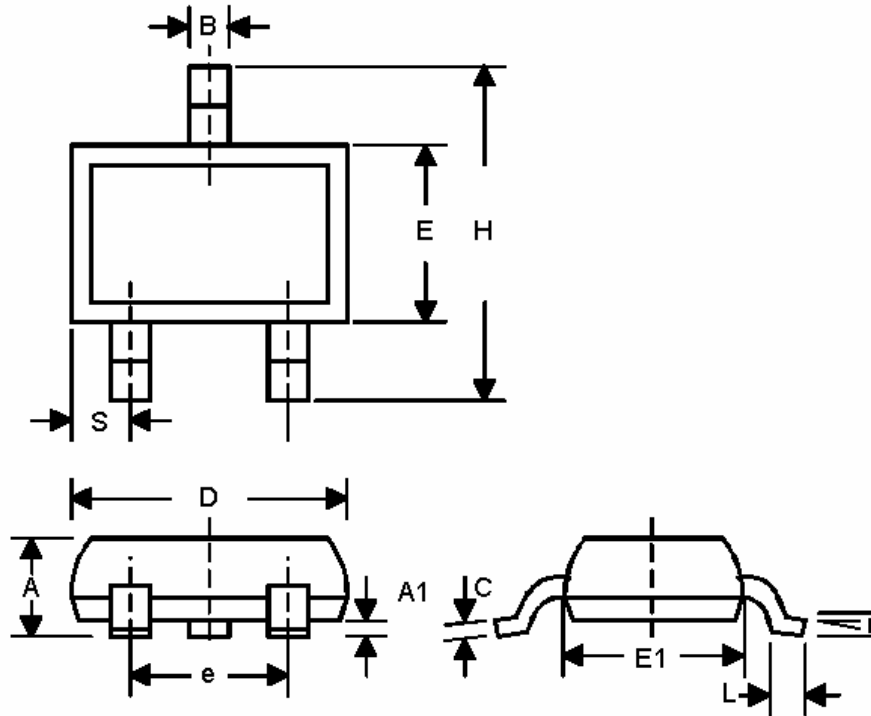

SYMBOL	MILLIMETERS		INCHES	
	MIN	MAX	MIN	MAX
A	0.787	1.194	0.031	0.047
A1	0.025	0.127	0.001	0.005
B	0.356	0.559	0.014	0.022
C	0.086	0.152	0.0034	0.006
D	2.667	3.048	0.105	0.120
E	1.194	1.397	0.047	0.055
E1	1.778	2.032	0.070	0.080
H	2.083	2.489	0.082	0.098
L	0.102	0.305	0.004	0.012
S	0.432	0.559	0.017	0.022
R	0°	8°	0°	8°

7F, No.9, PARK AVENUE II, Science-Based Industrial Park, Hsinchu 300, Taiwan, R.O.C.

Tel: 886-3-563-0878

Fax: 886-3-563-0879

WWW: <http://www.aimtron.com.tw>

2/8/2006 REV:1.1

Email: service@aimtron.com.tw

TO-92

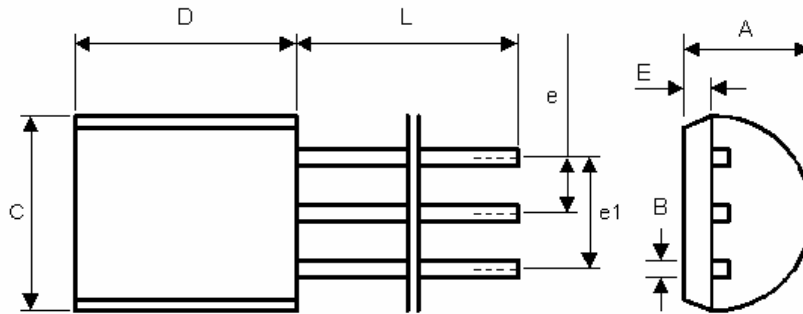

SYMBOL	MILLIMETERS		INCHES	
	MIN	MAX	MIN	MAX
A	3.4	3.8	0.134	0.150
B	0.3	0.5	0.012	0.020
C	4.4	4.8	0.173	0.189
D	4.4	4.8	0.173	0.189
E	0.9	1.5	0.035	0.059
e	1.17	1.37	0.046	0.054
e1	2.39	2.69	0.094	0.106
L	12	16	0.472	0.630

Reflow Profiles

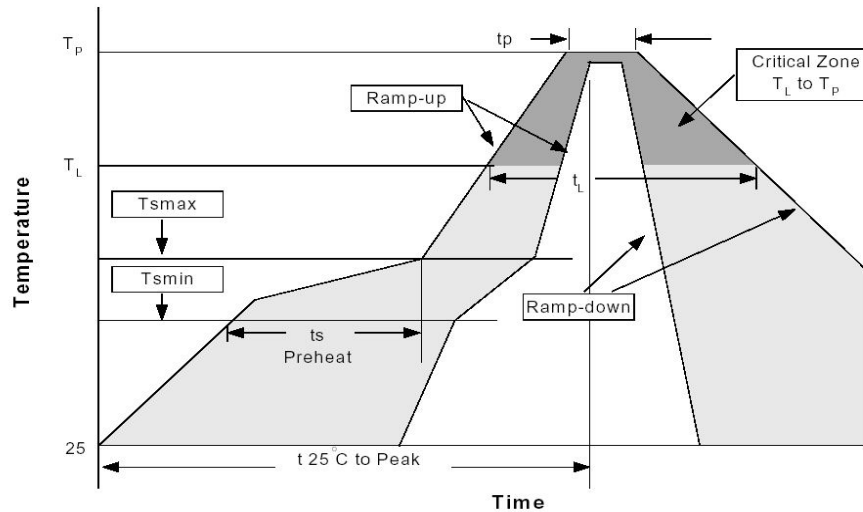

Profile Feature	Sn-Pb Eutectic Assembly		Pb-Free Assembly	
	Large Body Pkg. thickness $\geq 2.5\text{mm}$ or Pkg. volume $\geq 350\text{mm}^3$	Small Body Pkg. thickness $< 2.5\text{mm}$ or Pkg. volume $< 350\text{mm}^3$	Large Body Pkg. thickness $\geq 2.5\text{mm}$ or Pkg. volume $\geq 350\text{mm}^3$	Small Body Pkg. thickness $\geq 2.5\text{mm}$ or Pkg. volume $\geq 350\text{mm}^3$
Average ramp-up rate (T_L to T_p)	3°C/second max.		3°C/second max.	
Preheat				
-Temperature Min(T_{smin})	100°C		150°C	
-Temperature Max (T_{smax})	150°C		200°C	
-Time (min to max)(t_s)	60-120 seconds		60-180 seconds	
T_{smax} to T_L			3°C/second max.	
-Ramp-up Rate				
Time maintained above:				
-Temperature (T_L)	183°C		217°C	
-Time (t_L)	60-150 seconds		60-150 seconds	
Peak Temperature(T_p)	225+0/-5°C	240+0/-5°C	245+0/-5°C	250+0/-5°C
Time within 5°C of actual Peak Temperature (t_p)	10-30 seconds	10-30 seconds	10-30 seconds	20-40 seconds
Ramp-down Rate	6°C/second max.		3°C/second max.	
Time 25°C to Peak Temperature	6 minutes max.		8 minutes max.	

*All temperatures refer to topside of the package, measured on the package body surface.