

Features

- Full compliance with USB spec Rev 1.0
- Four downstream ports
- Full speed and low speed data transfers
- Self-Powered or Bus-Powered modes of operation
- Per port overcurrent monitoring
- Individual port power switch control
- USB connection status indicators

Description

The AT43312 is a 5 port USB hub chip supporting one upstream and four downstream ports. The AT43312 connects to an upstream hub or Host/Root Hub via Port0 and the other ports connect to external downstream USB devices. The hub re-transmits the USB differential signal between Port0 and Ports[1:4] in both directions. A USB hub with the AT43312 can operate as a bus-powered or self-powered through chip's power mode configuration pin. The AT43312 is pin- and function-compatible with the AT43311 and can be used as a replacement for the AT43310 with one pin modification.

The AT43312 supports the 12 Mb/s full-speed as well as 1.5 Mb/s slow-speed USB transactions. To reduce EMI, the AT43312's oscillator frequency is 6 MHz even though some internal circuitry operates at 48 MHz.

Pin Configurations

SOIC/DIP

$\overline{\text{PWR2}}$	1	32	$\overline{\text{PWR1}}$
$\overline{\text{PWR3}}$	2	31	DP4
$\overline{\text{PWR4}}$	3	30	DM4
VCC5	4	29	DP3
GND	5	28	DM3
OSC1	6	27	GND
OSC2	7	26	DP2
LFT	8	25	DM2
VCCA	9	24	VCC3
$\overline{\text{OVL4}}$	10	23	DP1
$\overline{\text{OVL3}}$	11	22	DM1
$\overline{\text{OVL2}}$	12	21	DP0
$\overline{\text{OVL1}}$	13	20	DM0
VREF	14	19	STAT1
BUS/SELF	15	18	STAT2
STAT4	16	17	STAT3



Self- and Bus-Powered USB Hub Controller

AT43312



Block Diagram

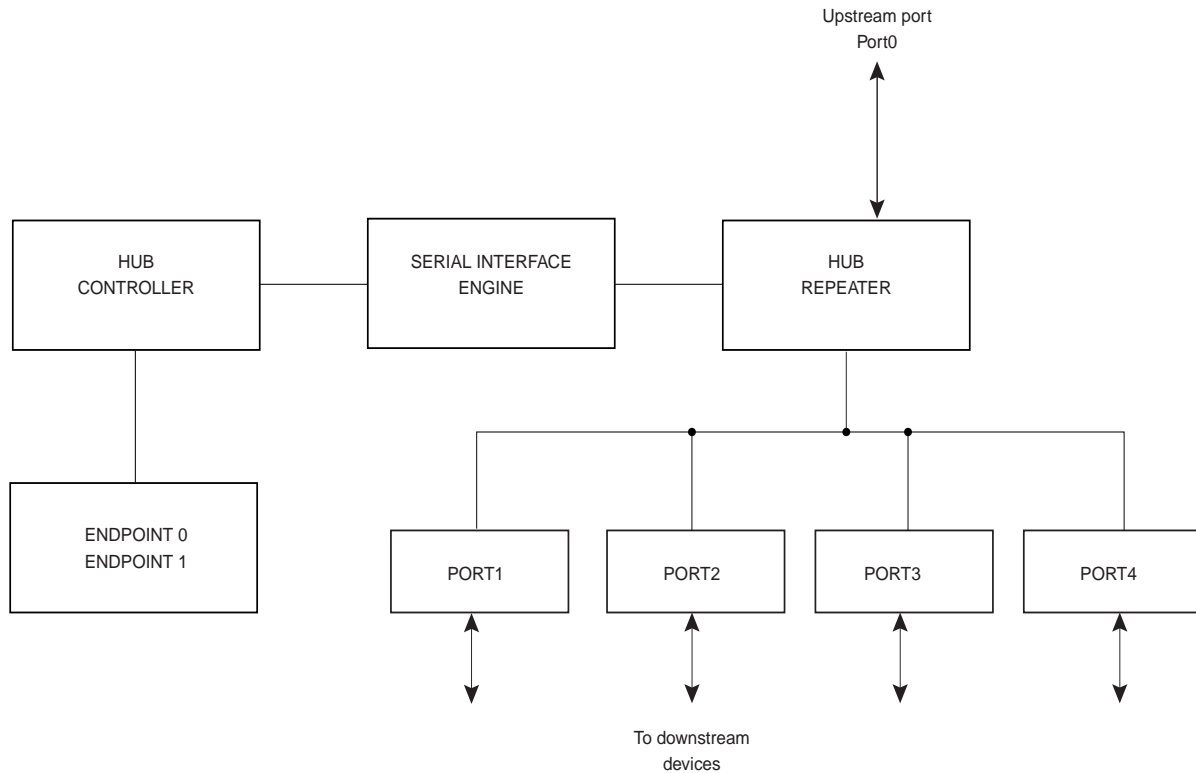

Note: This document assumes that the reader is familiar with the Universal Serial Bus and therefore only describes the unique features of the AT43312 chip. For detailed information about the USB and its operation, the reader should refer to the Universal Serial Bus Specification Version 1.0, January 19, 1996.

Figure 1. Device Pins

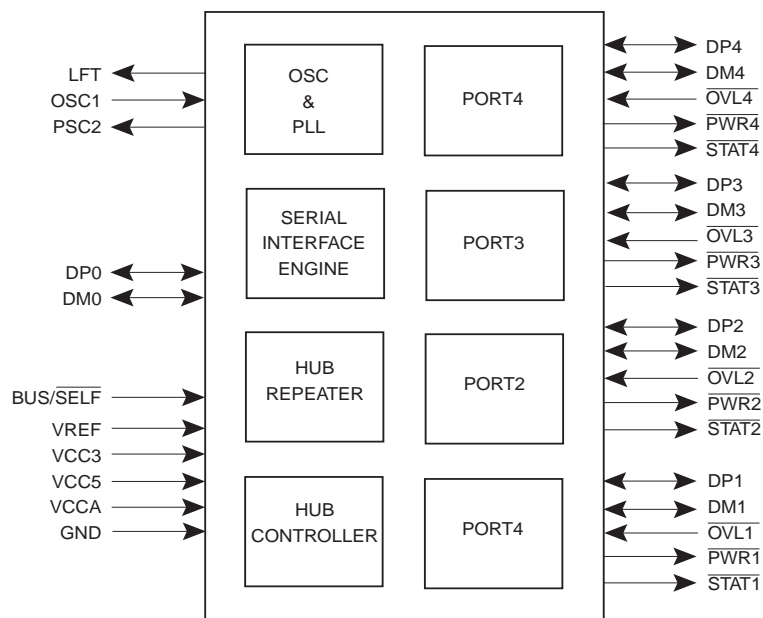

Pin Description

Pin Description	Pin Type	Description
OSC1	I	Oscillator Input. Input to the inverting 6 MHz oscillator amplifier.
OSC2	O	Oscillator Output. Output of the inverting oscillator amplifier.
LFT	I	PLL Filter. For proper operation of the PLL, this pin should be connected through a 2.2 nF capacitor in parallel with a 100 Ω resistor in series with a 10 nF capacitor to ground (GND)
$\overline{\text{BUS/SELF}}$	I	Hub Power Mode. Input signal that sets the bus or self-powered mode operation. A high on this pin enables the bus-powered mode, a low the self-powered mode.
VREF	I	Reference Voltage. This is an input pin that should be connected to an external voltage source. V_{REF} is used internally as the reference voltage by the overload protection circuit to decide whether there is a problem with a port's power.
DP0	B	Upstream Plus USB I/O. This pin should be connected to V_{CC} through an external 1.5 K Ω pullup resistor. DP0 and DM0 form the differential signal pin pairs connected to the Host Controller or an upstream Hub.
DM0	B	Upstream Minus USB I/O
DP[1:4]	B	Port Plus USB I/O. This pin should be connected to V_{SS} through an external 15 K Ω resistor. DP[1:4] and DM[1:4] are the differential signal pin pairs to connect downstream USB devices.
DM[1:4]	B	Port Minus USB I/O. This pin should be connected to V_{SS} through an external 15 K Ω resistor.
$\overline{\text{OVC}}[1:4]$	I	Overcurrent. This is the input signal used to indicate to the AT43312 that an overcurrent is detected at the port. If $\overline{\text{OVC}}$ is asserted, AT43312 will assert the $\overline{\text{PWRx}}$ pin and report the status to the USB Host.
$\overline{\text{PWR}}[1:4]$	OD	Power Switch. This is an output signal used to enable or disable the external voltage regulator supplying power to a port. $\overline{\text{PWRx}}$ is de-asserted when a power supply problem is detected at $\overline{\text{OVCx}}$.
$\overline{\text{STAT}}[1:4]$	O	Connect Status. This is an output pin indicating that a port is properly connected. $\overline{\text{STATx}}$ is asserted when the port is enabled.
V_{CC3}	V	3.3V Power Supply
V_{CC5}	V	5V Power Supply
V_{CCA}	V	5V Analog Power Supply
GND	V	Ground

Note: Signals with a # are active low.

Functional Description

The Atmel AT43312 is a USB hub controller for use in a standalone hub, as well as an add-on hub for an existing non-USB peripheral such as a PC display monitor or keyboard. In addition to supporting the standard USB hub functionality, the AT43312 has additional features to enhance the user friendliness of the hub.

USB Ports

The AT43312's downstream ports are standard USB ports. That is, their functionality complies to the USB specification and any USB compliant device can be attached to these ports without any other circuitry or modification. Each port has a port connectivity status pin.

Dp And Dm Configuration

To match the full-speed cable impedance, 27 Ω series resistors must be connected between each port's DM and DP pins to their corresponding USB connector. In addition, 15 K Ω pull-down resistors are required at each downstream port's DM and DP pins. Port0 is a full-speed port and requires a 1.5 K Ω pull-up resistor to the 3.3V power supply. This power supply must be derived from the bus supplied power.

Port Status Pin

The \overline{STATx} pins are signals that are not required by the USB specification. Their function is to allow the hub to provide feedback to the user whenever a device is properly connected to the port. A LED and series resistor connected to \overline{STATx} can be used to provide a visual feedback.

The default state of \overline{STATx} is inactive. After a port is enabled, AT43312 will assert the port's \overline{STATx} . Any condition that causes the port to be disabled inactivates \overline{STATx} .

Hub Repeater

The Hub Repeater is responsible for port connectivity setup and tear-down. It also supports exception handling such as bus fault detection and recovery, and connect/disconnect detection. Port0 is the root port and is connected to the root hub or an upstream hub. When a packet is received at Port0, the AT43312 propagates it to all of the enabled downstream ports. Conversely, a packet from a downstream port is transmitted from Port0.

The AT43312 supports downstream port data signaling at both 1.5 Mb/s and 12 Mb/s. Devices attached to the downstream ports are determined to be either full-speed or low-speed depending on which data line (DP or DM) is pulled high. If a port is enumerated as low speed, its output buffers operate at a slew rate of 75-300 ns, and the AT43312 will not propagate any traffic to that port unless it is prefaced with a preamble PID. Low-speed data following the preamble PID is propagated to both low and full-speed devices. The AT43312 will enable low-speed drivers within four full-speed bit times of the last bit of a preamble PID,

and will disable them at the end of an EOP. Packets out of Port0 are always transmitted using the full-speed drivers.

All the AT43312 ports independently drive and monitor their DP and DM pins so that they are able to detect and generate the 'J', 'K', and SE0 bus signaling states. Each hub port has single-ended and differential receivers on its DP and DM lines. The ports I/O buffers comply to the voltage levels and drive requirements as specified in the USB Specifications Rev 1.0.

The Hub Repeater implements a frame timer which is timed by the 12MHz USB clock and gets reset every time a SOF token is received from the Host.

Serial Interface Engine

The Serial Interface Engine handles the USB communication protocol. It performs the USB clock/data separation, the NRZI data encoding/decoding, bit stuffing, CRC generation and checking, USB packet ID decoding and generation, and data serialization and de-serialization. The on-chip phase locked loop generates the high-frequency clock for the clock/data separation circuit.

Power Management

A hub is a high-powered device and is allowed to draw up to 500 mA of current from the host or upstream hub. The AT43312 chip itself and its external hub circuitry consume less than 100 mA. The AT43312's power management logic work with external devices to detect overcurrent and control power to the ports.

Overcurrent sensing is on a per port basis and is achieved through the \overline{OVCx} pins. Each of the \overline{OVCx} pin is the plus input of an analog comparator whose other input is connected to a reference voltage source, V_{REF} which is common to all four ports. Whenever the voltage at \overline{OVCx} is less than V_{REF} , the AT43312 treats it as an overcurrent condition. This could be caused by an overload, or even a short circuit, and causes the AT43312 to set the port's $\overline{PORT_OVER_CURRENT}$ status bit and its $\overline{C_PORT_OVER_CURRENT}$ status change bit. At the same time, power to the offending port is shut off.

An external device is needed to perform the actual switching of the ports' power under control of the AT43312. The signal to control the external switches are the \overline{PWRx} pins which are open drain signals and require external pull-up resistors of 10 K Ω . Any type of suitable switch or device is acceptable. However, it should have a low-voltage drop across it even when the port absorbs full power. In its simplest form, this switch can be a P-channel MOSFET. The advantages of using a MOSFET switch is its very low voltage drop and low cost.

Each one of the AT43312's port has its own power control pin which is asserted only when a `Set_Port_Feature[PORT-POWER]` request is received

from the host. $\overline{\text{PWRx}}$ is de-asserted under the following conditions:

1. Power up
2. Reset and initialization
3. Overcurrent condition

Self-powered Mode

In the self-powered mode, power to the downstream ports must be supplied by an external power supply. This power supply must be capable of supplying 500 mA per port.

The USB specifications require that the voltage drop at the power switch, and board traces be no more than 100 mV. A good conservative maximum drop at the power switch itself should be no more than 750 mV. Careful design and selec-

tion of the power switch and PC board layout is required to meet the specifications. When using a MOSFET switch, its resistance must be 140 M Ω or less, under worst case conditions. A suitable MOSFET switch for an AT43312 based hub is a P-channel enhancement mode MOSFET. The input of the PMOS switch is connected to the local 5V power supply while the output is connected to the port power line, as well as the port's $\overline{\text{OVCx}}$ pin. An overcurrent condition increases the voltage drop across the MOSFET. If this voltage drops to less than the voltage at V_{REF} , the AT43312 voltage reference pin, the AT43312 interpretes this as an overcurrent condition. The AT43312 removes the power from that port by de-activating the port's $\overline{\text{PWRx}}$ pin and reports the condition to the Host.

Figure 2. Self-Powered Hub Power Supply

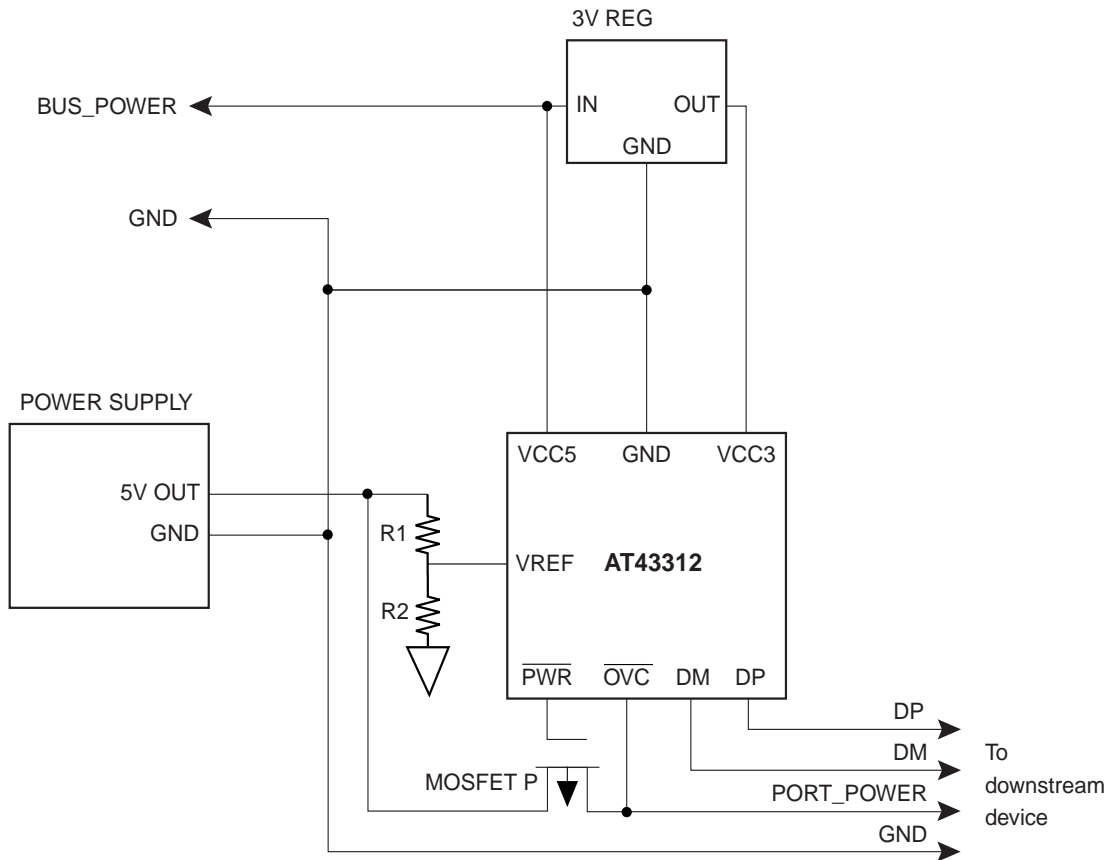

Bus-powered Mode

In the bus-powered mode, all the power for the hub itself as well as the downstream ports are supplied by the root hub or upstream hub through the USB. Only 100 mA is available for each of the hub's downstream devices and therefore only low power devices are supported.

The power switch and overcurrent protection work exactly like the self-powered mode, except that the allowable switch resistance is higher: 700 M Ω or less under the worst-case condition.

The diagrams of Figures 2 and 3 show examples of the power supply and management connections for a typical AT43312 port in the self-powered mode and bus-powered mode.

Figure 3. Bus-Powered Hub Power Supply

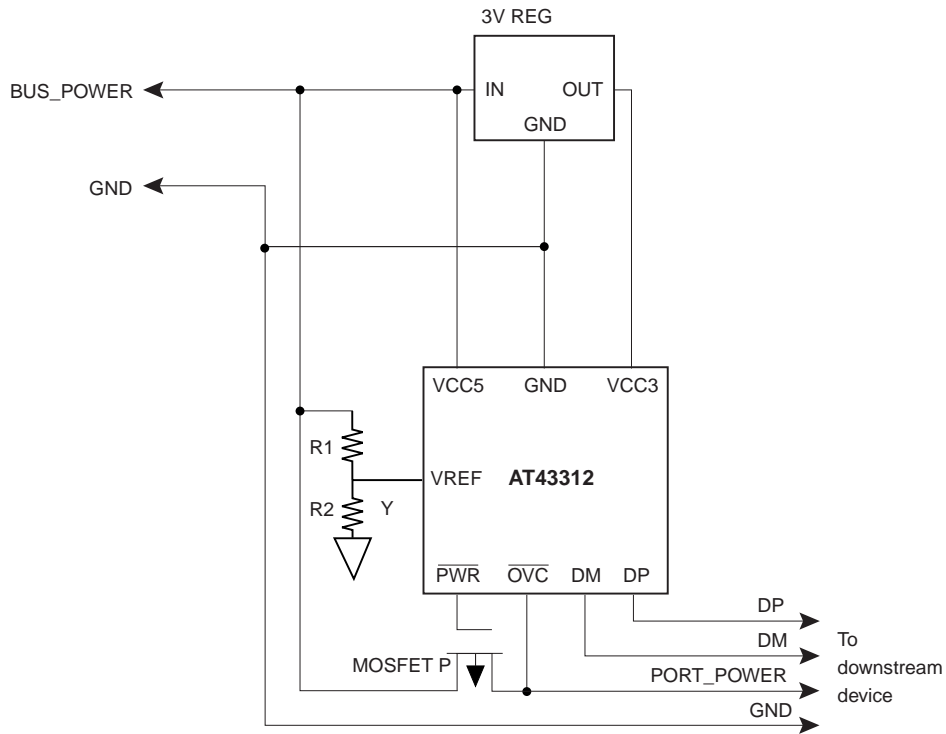

Hub Controller

The Hub Controller of the AT43312 provides the mechanism for the Host to enumerate the Hub, and the AT43312 to provide the Host with its configuration information. It also provides a mechanism for the Host to monitor and control the downstream ports. Power is applied, on a per port basis, by the Hub Controller upon receiving a command, Set_Port_Feature[PORT_POWER], from the Host. The

AT43312 itself must be configured first by the Host before the Hub Controller can apply power to external devices.

The Hub Controller contains two endpoints, Endpoint0 and Endpoint1, and maintains a status register, Controller Status Register, which reflects the AT43312's current settings. At power up, all bits in this register will be set to 0's.

Control Status Register

Bit	Function	Value	Description
0	Hub configuration status	0 1	Set to 0 or 1 by a Set_Configuration Request Hub is not currently configured Hub is currently configured
1	Hub remote wakeup status	0 1	Set to 0 or 1 by ClearFeature or SetFeature request. Default value is 0. Hub is currently not enabled to request remote wakeup Hub is currently enabled to request remote wakeup
2	Endpoint0 STALL status	0 1	Endpoint0 is not stalled Endpoint0 is stalled
3	Endpoint1 STALL status	0 1	Endpoint1 is not stalled Endpoint1 is stalled

Endpoint0

Endpoint0 is the AT43312's default endpoint used for enumeration of the Hub and exchange of configuration information and requests between the Host and the AT43312. Endpoint0 supports control transfers.

The Hub Controller supports the following descriptors: Device Descriptor, Configuration Descriptor, Interface Descriptor, Endpoint Descriptor, and Hub Descriptor. These Descriptors are described in detail on page 9 through page 16 of this document. Standard USB Device Requests and class-specific Hub Requests are also supported through Endpoint0. There is no endpoint descriptor for Endpoint0.

Status Change Register

Bit	Function	Value	Meaning
0	Hub status change	0	No change in status
		1	Change in status detected
1	Port1 status change	0	No change in status
		1	Change in status detected
2	Port2 status change	0	No change in status
		1	Change in status detected
3	Port3 status change	0	No change in status
		1	Change in status detected
4	Port4 status change	0	No change in status
		1	Change in status detected
5-7	Reserved	000	Default values

An IN Token packet from the Host to Endpoint1 indicates a request for port change status. If the Hub has not detected any change on its ports, nor any changes in itself, then all bits in this register will be 0 and the Hub Controller will return a NAK to requests on Endpoint1. If any of bits 0-4 is 1, the Hub Controller will transfer the whole byte. The Hub

Endpoint1

Endpoint1, an interrupt endpoint, is used by the Hub Controller to send status change information to the Host.

The Hub Controller samples the changes at the end of every frame at time marker EOF2 in preparation for a potential data transfer in the subsequent frame. The sampled information is stored in a byte-wide register, the Status Change Register, using a bitmap scheme.

Each bit in the Status Change Register corresponds to one port as shown below:

Controller will continue to report a status change when polled until that particular change has been removed by a Clear_Port_Feature request from the Host. No status change will be reported by Endpoint1 until the AT43312 has been enumerated and configured by the Host via Endpoint0.

Oscillator and Phase-Locked-Loop

All the clock signals required to run the AT43311 are derived from an on-chip oscillator. To reduce EMI and power dissipation in the system, the oscillator is designed to operate with a 6 MHz crystal. An on-chip PLL generates the high-frequency for the clock/data separator of the Serial Interface Engine. In the suspended state, the oscillator circuitry is turned off. To assure quick startup, a crystal with a high Q, or low ESR, should be used. To meet the USB hub frequency accuracy and stability requirements for hubs, the crystal should have an accuracy and stability of better than 500 PPM. Even though the oscillator circuit would work with a ceramic resonator, its use is not recommended because a resonator would not have the frequency accuracy and stability.

A 6 MHz series resonance quartz crystal with a load capacitance of approximately 10 pF is recommended. If the crystal recommended load capacitor is larger, external capacitors added to pins OSC1 and OSC2 are recommended. The values for these capacitors depends on the crystal and the layout of the board, but a starting value of 22 pF at OSC1 and OSC2 should work fine in most cases. If the crystal used cannot tolerate the drive levels of the oscillator, a series resistor between OSC2 and the crystal pin is recommended.

The clock can also be externally sourced. In this case, connect the clock source to the OSC1 pin, while leaving OSC2 pin floating. The switching level at the OSC1 pin can be as low as 0.47V (see "Oscillator Signals: OSC1, OSC2" table on page 18) and a CMOS device is required to drive this

pin to maintain good noise margins at the low switching level.

Figure 4. Oscillator and PLL Connections

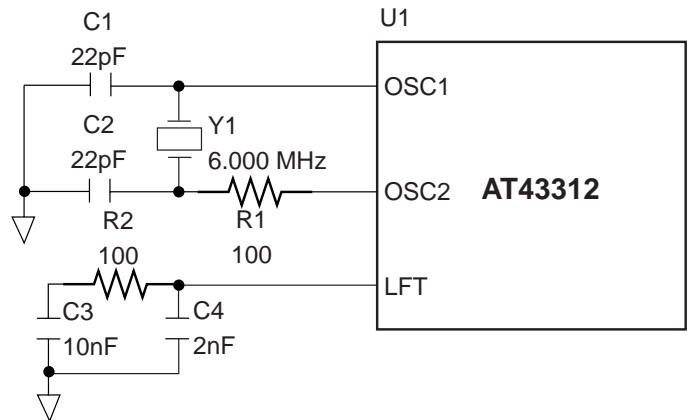

For proper operation of the PLL, an external RC filter consisting of a series RC network of 100 Ω and 10 nF in parallel with a 2 nF capacitor must be connected from the LFT pin to V_{SS} .

To provide the best operating condition for the AT43312, careful consideration of the power supply connections are recommended. Use short, low impedance connections to all power supply lines: V_{CC} , V_{CCA} and V_{SS} . Use sufficient decoupling capacitors to reduce noise: 0.1 μ F decoupling high-quality capacitors, soldered as close as possible to the package pins are recommended.

Descriptors

The Hub Controller supports the following standard USB descriptors: Device, Configuration, Interface, and Endpoint Descriptors, as well as the class-specific Hub Descriptor. All the obligatory Standard Requests and Hub Class-Specific

Requests are supported by the AT43312's Hub Controller. The description is given for the self-powered mode of operation. Unique parameters for the bus-powered mode is given in case of differences.

Device Descriptor

The Device Descriptor provides general information about the AT43312 Hub.

Offset	Field	Description	Size (bytes)	Value
0	bLength	Define size of this descriptor = 18 bytes	1	0x12
1	bDescriptorType	Device descriptor type	1	0x01
2	bcdUSB	USB Spec. Release Number = Rev 1.0	2	0x00 0x01
4	bDeviceClass	Class code = HUB_CLASSCODE = 09	1	0x09
5	bDeviceSubClass	Subclass code	1	0x00
6	bDeviceProtocol	Protocol code	1	0x00
7	wMaxPacketSize0	Max. packet size for Endpoint0 = 8 bytes	1	0x08
8	idVendor	Vendor ID = Atmel Corporation	2	0xEB 0x03
10	idProduct	Product ID = AT43312	2	0x12 0x33
12	bcdDevice	Device release number Example : Revision A0 : yy = 0x01, zz = 0x00 Revision B1 : yy = 0x02, zz = 0x01	2	0XZZ 0XYY
14	iManufacturer	Index of string descriptor describing manufacturer = not supported	1	0x00
15	iProduct	Index of string descriptor describing product = not supported	1	0x00
16	iSerialNumber	Index of string descriptor describing device's serial no. = not supported	1	0x00
17	bNumConfigurations	Number of possible configurations = 1	1	0x01

Configuration Descriptor

This Configuration Descriptor provides information about AT43312's configuration.

Offset	Field	Description	Size (bytes)	Value
0	bLength	Define size of this descriptor = 9 bytes	1	0x09
1	bDescriptorType	Descriptor type = Configuration	1	0x02
2	wTotalLength	Total length of data returned for this configuration. Consists of the combined length of configuration, interface, endpoint and hub descriptors = 34 bytes	2	0x22 0x00
4	bNumInterface	Number of interfaces supported by this configuration	1	0x01
5	bConfiguration Value	Argument value for this configuration to be used by Set Configuration command	1	0x01
6	iConfiguration	Index of string descriptor describing this configuration (not supported)	1	0x00
7	bmAttributes	Configuration characteristics = Bus and Self-Powered with Remote Wakeup	1	0xE0
8	MaxPower	Maximum power consumption of USB device from bus = 100 mA	1	0x32

Bus Powered Mode:

Offset	Field	Description	Size (bytes)	Value
7	bmAttributes	Configuration characteristics = Bus-Powered with Remote Wakeup	1	0xA0
8	MaxPower	Maximum power consumption of USB device from bus = 500 mA	1	0xFA

Interface Descriptor

The Interface Descriptor provides information about the single interface which the AT43312 supports.

Offset	Field	Description	Size (bytes)	Value
0	bLength	Define size of this descriptor = 9 bytes	1	0x09
1	bDescriptorType	Descriptor type = Interface	1	0x04
2	bInterfaceNumber	Number of interface = 1, index = 0	1	0x00
3	bAlternatSetting	Alternate setting value for the interface identified in the prior field = 0	1	0x00
4	bNumEndpoints	Number of endpoints used by this interface = 1	1	0x01
5	bInterfaceClass	Class code = HUB_CLASSCODE = 09	1	0x09
6	bInterfaceSubClass	Subclass code = 0	1	0x00
7	bInterfaceProtocol	Protocol code = 0	1	0x00
8	iInterface	Index of string descriptor describing this interface = not supported	1	0x00

Endpoint Descriptor

There is no endpoint descriptor for Endpoint0. This descriptor describes the Endpoint1 descriptor which the Hub uses for status change report.

Offset	Field	Description	Size (bytes)	Value
0	bLength	Size of this descriptor = 7 bytes.	1	0x07
1	bDescriptorType	Descriptor type = Endpoint	1	0x05
2	bEndpointAddress	The address of the IN endpoint	1	0x81
3	bmAttributes	Transfer Type = Interrupt	1	0x03
4	wMaxPacketSize	Max. packet size Endpoint1 is capable of sending = 1 byte	2	0x01 0x00
6	blInterval	Interval for polling endpoint for data transfers = 256 ms	1	0xFF

Hub Descriptor

This descriptor describes the AT43312's Hub and ports.

Offset	Field	Definition	Size (bytes)	Value
0	bDescLength	Define size of this descriptor = 9 bytes	1	0x09
1	bDescriptor Type	Descriptor Type = HUB_DESCRIPTOR = 29	1	0x29
2	bNbrPorts	Number of downstream ports = 4	1	0x04
3	wHubCharacteristics	Hub's characteristics: = Individual power switching = Hub is not part of a compound device = Individual Port Over-current Protection	2	0x09 0x00
5	bPwrOn2PwrGood	Time from the time power-on sequence begins on a port until power is good on that port = 100ms.	1	0x32
6	bHubContrCurrent	Maximum current requirements of the hub electronics = 100 mA.	1	0x64
7	DeviceRemovable	Indicates if a port has removeable device. All downstream ports have removable devices.	1	0x00
8	PortPwrCtrlMask	Indicates if a port is not affected by gang-mode power control request. All the AT43312's ports require manual SetPortFeature(PORT_POWER) request to control the port's power state.	1	0x1E

Standard Requests

Standard Requests, or commands, are sent to the AT43312 from the Host on the AT43312's default pipe. These requests are made using control transfers to endpoint0. The request and request parameters are sent in a Setup packet which consists of eight bytes. The following sections describe which requests are supported by the AT43312 and the corresponding responses, as well as those requests not supported and responded with a STALL packet. Please refer to the USB specifications for details about the standard requests.

Clear_Feature [Device]

Disable remote wakeup feature.

Clear_Feature [Interface]

Not supported, respond with a STALL.

Clear_Feature [Endpoint]

Clear an endpoint's halt status bit if the condition causing the stall has been removed.

Get_Configuration

Return one byte of data. Bit 0 will be a copy of bit 0 of the Controller_Status Register. All other bits will be set to 0.

Get_Descriptor

Return the appropriate descriptor. The last word of the Get_Descriptor request specifies the number of bytes AT43312 is to return. If the requested descriptor is longer than the requested number of bytes, AT43312 will return only the requested number of bytes from the top of the descriptor. If the requested descriptor is shorter than the requested number of bytes, then the AT43312 indicates the end of the control transfer by sending a short data packet.

Get_Interface

The AT43312 has a single interface with a value of 0. If it receives a Get_Interface request with the value of 0x0000 as wIndex (bytes 2), and it will return a single byte with the value 0x00. For any other value of wIndex, the AT43312 will return a STALL.

Get_Status [Device]

Returns two bytes of data, byte 0 and byte 1, in little endian order. Byte 0, Bit 0 = 1, identifying the AT43312 as a self-powered device. Byte 0, Bit 1 = copy of bit 1 of the Controller_Status Register. This bit reflects whether the AT43312's remote wakeup capability is enabled or disabled. All other bits are set to 0. Bus-powered mode: Byte 0, Bit 0 = 0, identifying the AT43312 as a bus-powered device.

Get_Status [Interface]

Responds with two bytes of data with all 0 value.

Get_Status [Endpoint]

Responds with two bytes of data. The first bit of the first byte returned reflects the status of the endpoint halt status

bits of the Controller Status Register described on page 6. These bits are set or cleared depending whether the endpoint is stalled or not :

Current Endpoint Status	First Byte	Second Byte
Halt	01H	00H
Not halt	00H	00H

Set_Address

Saves the value of bytes 2 and 3 in a temporary buffer, and after successful completion of status stage, it will transfer the value into the Hub_Address Register. This value will be used as the Hub's address in all future transactions.

Set_Configuration

Sets bit 0 of the Controller_Status Register according to the value of byte 2 of the Setup packet. The AT43312 has only one configuration and it will set the bit only if byte 2 is either 00H or 01H, and bytes 3 to 7 are all zeroes. For any other values, the Hub will respond with a STALL handshake packet. If the value of byte 2 is 1, the AT43312 will be configured. If 0, it will go to its unconfigured state.

Set_Descriptor

Not supported. Will send a STALL handshake packet.

Set_Feature [Device]

Enables its remote wakeup feature.

Set_Feature [Interface]

Not supported and will respond with a STALL.

Set_Feature [Endpoint]

Sets the stall status bit of the Controller Status Register. The stalled endpoint now exhibits the same behavior as in a stall condition.

Set_Interface

The AT43312 has a single interface and responds with a STALL if a Set_Interface request is received with a value other than 0x0000 as wValue (alternative setting, bytes 2 and 3).

Sync_Frame

Not supported. Will respond with a STALL packet.

Hub-specific Requests

Hub-specific requests or commands are sent from the Host to the AT43312 using the Default Pipe (associated with Endpoint0). These requests are made using control transfers. The request and request parameters are sent in a setup packet consisting of eight bytes. Please refer to the USB specifications for details.

Clear_Hub_Feature

This request is used by the host to acknowledge local power and hub overcurrent changes. Upon receipt of this request with a wValue = 0, the AT43312 will clear the Local Power Status Change bit. The AT43312 has a per port overcurrent protection and does not report over-current on a global basis. If this request has a wValue = 1, the AT43312 will respond with a STALL.

Clear_Port_Feature

This request changes the status of a port according to which port feature the request addresses. Not all the possible port features are supported, because some have no meaning. Port features supported by the Clear_Port_Feature request are: PORT_ENABLE, PORT_SUSPEND, PORT_POWER, and all those affecting the port status change bits. A request with an unsupported feature, or if Port0 or a port higher than Port4 is addressed, will cause the hub to respond with a STALL.

Get_Bus_State

The AT43312 samples the bus states of Ports 1, 2, 3, and 4, at each EOF2 and will store the value in a register known as the Port_Bus_State registers. The value of the D- signal (pin DMx) will be in bit 0 and the value of the D+ signal (DPx) will be in bit 1 of each port's Port_Bus_State register. All other bits will be 0. The AT43312 responds with a STALL if Port0 or a port higher than Port4 is addressed in this request.

Get_Hub_Descriptor

Returns the Hub Descriptor. The last word of the Get_Hub_Descriptor request specifies the number of bytes AT43312 is to return. If the requested number of bytes is less than the 9 bytes length of the HubDescriptor, the AT43312 will return only the requested number of bytes from the top of the descriptor. If the requested number of bytes is more than 9, then the returned data will be padded with trailing bytes of zeroes.

Get_Hub_Status

Returns the current Hub status that has changed since the previous acknowledgment in the form of two words of data. This is described in the following two tables. Word0 is the Hub Status Field, wHubStatus, and Word1 is the Hub Change Field, wHubChange.

Hub Status Field, wHubStatus

Bit	Description
0	Local Power Status, indicates the state of the local power supply. 0 = Local power supply good 1 = Local power supply lost
	Over-Current Indicator, indicates over-current condition on a global hub basis. AT43312 reports over-current condition on a per port basis therefore this bit is always read as 0.
2-15	Reserved. Always read as 0's

Bus Powered Mode:

Bit	Description
0	Local Power Status. In the bus-powered configuration, the AT43312 will return a 0 if this bit is read.

Hub Change Field, wHubChange

Bit	Description
0	Local Power Status Change, C_HUB_OVER_POWER, corresponds to bit 0 of wHubStatus. 0 = No change has occurred in local power status 1 = Local power status has changed
1	Over-Current Indicator Change, C_HUB_OVER_CURRENT, corresponds to bit 1 of wHubStatus. AT43312 reports over-current condition on a per port basis and therefore this bit is always read as 0.
2-15	Reserved. Always read as 0's

Bus Powered Mode:

Bit	Description
0	Local Power Status Change. In the bus-powered configuration, the AT43312 will return as 0 if this bit is read.

Get_Port_Status

Returns the current port status and the states that have changed since the previous acknowledgment in the form of two words of data. This is described in the following two tables. Word0 is the Port Status Field, and Word1 is the

Port Change Field. The Hub Controller will respond with a STALL if Port0 or a port higher than Port4 is addressed in this request.

Port Status Field, wPortStatus

Bit	Description
0	Current Connect Status: PORT_CONNECTION 0 = no device present on this port 1 = a device is present on this port
1	Port Enabled/Disabled: PORT_ENABLE 0 = Port is disabled 1 = Port is enabled
2	Suspend: PORT_SUSPEND 0 = Not suspended 1 = Suspended
3	Over-Current Indicator: PORT_OVER_CURRENT 0 = Power operation normal for this port 1 = Over-current condition exists for this port. Power to this port has been shut off
4	Reset: PORT_RESET 0 = Reset signalling not asserted 1 = Reset signalling asserted
5-7	Reserved. Always read as 0's.
8	Port Power: PORT_POWER 0 = This port is powered OFF 1 = This port is powered ON
9	Low Speed Device Attached: PORT_LOW_SPEED 0 = Full Speed device attached to this port 1 = Low Speed device attached to this port
10-15	Reserved. Always read as 0's

Port Change Field, wPortChange

Bit	Description
0	Connect Status Change: C_PORT_CONNECTION 0 = No change has occurred on Current Connect status 1 = Current Connect Status has changed
1	Port Enable/Disable Change: C_PORT_ENABLE 0 = No change has occurred on Port Enabled/Disabled status 1 = Port Enabled/Disabled status has changed
2	Suspend Change: C_PORT_SUSPEND 0 = No change 1 = Resume complete
3	Over-Current Indicator Change: C_PORT_OVER_CURRENT 0 = No change has occurred on Over-Current indicator 1 = Over-Current indicator has changed
4	Reset Change: C_PORT_RESET 0 = No change 1 = Reset complete
5-15	Reserved. Always read as 0's.



Set_Hub_Descriptor

The AT43312 has one Hub Descriptor only and therefore does not support this request. It will respond with a STALL.

Set_Hub_Feature

Sets a value reported in the Hub status. The status relates to the local power and over-current. AT43312 does not support this request and will respond with a STALL.

Set_Port_Feature

This request changes the status of a port according to which port feature the request addresses. Not all the possible port features are supported because some have no meaning. Port features supported by the Set_Port_Feature request are: PORT_ENABLE, PORT_SUSPEND, PORT_RESET and PORT_POWER. A request with an unsupported feature, or if Port0 or a port higher than Port4 is addressed, will cause the hub to respond with a STALL.

Port Feature Selector Table

Feature	Value
PORT_CONNECTION	0
PORT_ENABLE	1
PORT_SUSPEND	2
PORT_OVER_CURRENT	3
PORT_RESET	4
PORT_POWER	8
PORT_LOW_SPEED	9
C_PORT_CONNECTION	16
C_PORT_ENABLE	17
C_PORT_SUSPEND	18
C_PORT_OVER_CURRENT	19
C_PORT_RESET	20

Absolute Maximum Ratings

Operating Temperature	-55°C to +125°C
Storage Temperature	-65°C to +150°C
Voltage on any pin with Respect to Ground	-1.0V to 7.0V
Maximum Operating Voltage.....	6.6V
DC Output Current.....	16 mA

***NOTICE:** Stresses beyond those listed below may cause permanent damage to the device. This is a stress rating only and functional operation of the device at these or any other conditions beyond those indicated in the operational sections of this specification is not implied. Exposure to absolute maximum rating conditions for extended periods may affect device reliability.

DC Characteristics

The values shown in this table are valid for TA = 0°C to 85°C, V_{CC5} = 4.4 to 5.25V, V_{CC3} = 3.0V to 3.6V, unless otherwise noted.

Power Supply

Symbol	Parameter	Condition	Min	Max	Unit
V _{CC5}	5V Power Supply		4.40	5.25	V
V _{CC3}	3.3V Power Supply		3.0	3.6	V
V _{CCA}	5V Analog Power Supply		4.40	5.25	V
I _{CC5}	5V Supply Current			40	mA
I _{CC3}	3V Supply Current			20	mA
I _{CCS}	Suspended Device Current			200	μA

USB Signals: DPx, DMx

Symbol	Parameter	Condition	Min	Max	Unit
I _{LO}	Hi-Z Data Line Leakage	0 V < V _{IN} < 3.3 V	-10	+10	μA
V _{DI}	Differential Input Sensitivity	DPx and DMx	0.2		V
V _{CM}	Differential Common Mode Range		0.8	2.5	V
V _{SE}	Single Ended Receiver Threshold		0.8	2.0	V
V _{OL1}	Static Output Low	RL of 1.5 KΩ to 3.6 V		0.3	V
V _{OH1}	Static Output High	RL of 15 KΩ to GND	2.8	3.6	V

PWRx, STATx

Symbol	Parameter	Condition	Min	Max	Unit
V _{OL1}	Output Low Level, $\overline{\text{STATx}}$	I _{OL} = 8 mA		0.5	V
V _{OL2}	Output Low Level, $\overline{\text{PWRx}}$	I _{OL} = 4 mA		0.5	V
C _{out}	Output capacitance	1 MHz		10	pF

Oscillator Signals: OSC1, OSC2

Symbol	Parameter	Condition	Min	Max	Unit
V_{LH}	OSC1 switching level		0.47	1.20	V
V_{HL}	OSC1 switching level		0.67	1.44	V
C_{X1}	Input capacitance, OSC1			9	pF
C_{X2}	Output capacitance, OSC2			9	pF
C_{12}	OSC1/2 capacitance			1	pF
t_{su}	Start-up time	6 MHz, fundamental		10	ms
D_L	Drive level	$V_{CC5} = 5V$, 6 MHz crystal, 120 Ω equiv series resistor		5	mW

Note: OSC2 must not be used to drive other circuitry.

Comparator Signals: V_{REF} , \overline{OVLx}

Symbol	Parameter	Condition	Min	Max	Unit
V_{OS}	Input Offset voltage		-20	+20	mV
A_0	Open loop gain		80		dB
CM_{IRL}	Input CM range low			0	V
CM_{IRH}	Input CM range high		V_{CC5}		V
CM_{RR}	CM rejection ratio	1 KHz	92		dB
C_{INR}	Input capacitance, $\overline{V_{REF}}$			10	pF
C_{INL}	Input capacitance, all other			6	pF

AC Characteristics

Dpx, Dmx Driver Characteristics, Full Speed Operation

Symbol	Parameter	Condition	Min	Max	Unit
T _R	Rise time	C _L = 50 pF	4	20	ns
T _F	Fall time	C _L = 50 pF	4	20	ns
TRFM	TR/TF matching		90	110	%
V _{CRS}	Output signal crossover		1.3	2.0	V
Z _{DRV}	Driver output resistance ⁽¹⁾	Steady state drive	29	44	Ω

Note: 1. with external 27 Ω series resistor

Dpx, Dmx Data Source Timings, Full Speed Operation

Symbol	Parameter	Condition	Min	Max	Unit
T _{DRATE}	Full Speed Data Rate	Average Bit Rate	11.97	12.03	Mbs
T _{FRAME}	Frame Interval		0.9995	1.0005	ms
T _{DJ1}	Source Diff Driver Jitter To Next Transition		-3.5	3.5	ns
T _{DJ2}	For Paired Transitions		-4.0	4.0	ns
T _{EOPT}	Source EOP Width		160	175	ns
T _{DEOP}	Differential to EOP Transition Skew		-2	5	ns
T _{JR1}	Recvr Data Jitter Tolerance To Next Transition		-18.5	18.5	ns
T _{JR2}	For Paired Transitions		-9	9	ns
T _{EOPR1}	EOP Width at Receiver Must Reject as EOP		40		ns
T _{EOPR2}	Must Receive as EOP		82		ns

DPx, DMx Driver Characteristics, Low Speed Operation

Symbol	Parameter	Condition	Min	Max	Unit
T_R	Rise time	$C_L = 50 \text{ pF}$	75		ns
T_R	Rise time	$C_L = 350 \text{ pF}$		300	ns
T_F	Fall time	$C_L = 50 \text{ pF}$	75		ns
T_F	Fall time	$C_L = 350 \text{ pF}$		300	ns
TRFM	TR/TF matching		80	120	%
V_{CRS}	Output signal crossover		1.3	2.0	V

Dpx, Dmx Hub Timings, High Speed Operation

Symbol	Parameter	Condition	Min	Max	Unit
T_{HDD1} T_{HDD2}	Hub Differential Data Delay with cable without cable			70 40	ns ns
T_{HDJ1} T_{HDJ2}	Hub Diff Driver Jitter To Next Transition For Paired Transitions		-3 -1	3 1	ns ns
T_{SOP}	Data Bit Width Distortion after SOP		-5	3	ns
T_{EOPD}	Hub EOP Delay Relative to THDD		0	15	ns
T_{HESK}	Hub EOP Output Width Skew		-15	15	ns

Dpx, Dmx Hub Timings, Low Speed Operation

Symbol	Parameter	Condition	Min	Max	Unit
T_{LHDD}	Hub Differential Data Delay			300	ns
T_{LHDJ1} T_{LHDJ2}	Downstr Hub Diff Driver Jitter To Next Transition For Paired Transitions		-45 -15	45 15	ns ns
T_{SOP}	Data Bit Width Distortion after SOP		-60	45	ns
T_{LEOPD}	Hub EOP Delay Relative to THDD		0	200	ns
T_{LHESK}	Hub EOP Output Width Skew		-300	300	ns

Packaging Information

32R, 32-Lead, 0.440" Wide,
Plastic Gull Wing Small Outline (SOIC)
Dimensions in Inches and (Millimeters)

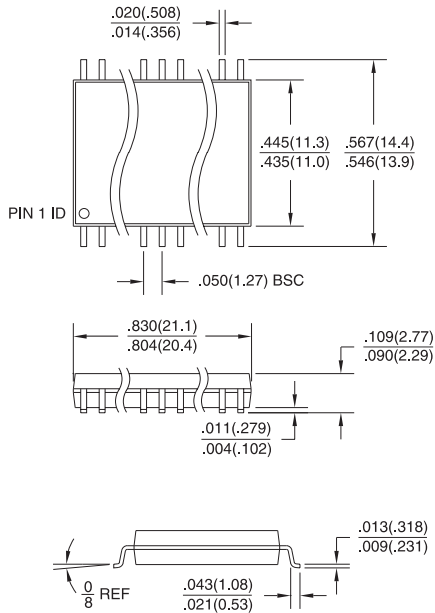

32P6, 32-Lead, 0.600" Wide,
Plastic Dual Inline Package (PDIP)
Dimensions in Inches and (Millimeters)

