



PRELIMINARY

CY8C20111, CY8C20121

CapSense Express™ - One Button and Two Button Capacitive Controllers

1. Features

- Capacitive Button Input tied to a Configurable Output
 - Robust sensing algorithm
 - High sensitivity, low noise
 - Immunity to RF and AC noise
 - Low radiated EMC noise
 - Supports wide range of input capacitance, sensor shapes, and sizes
- Target Applications
 - Printers
 - Cellular handsets
 - LCD monitors
 - Portable DVD players
- Industry's Best Configurability
 - Custom sensor tuning
 - Output supports strong 20 mA sink current
 - Output state can be controlled through I²C or directly from CapSense input state
 - Run time reconfigurable over I²C
- Advanced Features
 - Plug-and-play with factory defaults – tuned to support up to 1 mm overlay
 - Nonvolatile storage of custom settings
 - Easy integration into existing products – configure output to match system
 - No external components required
 - World class free configuration tool
- Wide Range of Operating Voltages
 - 2.45V to 2.9V
 - 3.10V to 3.6V
 - 4.75V to 5.25V
- I²C Communication
 - Supported from 1.8V
 - Internal pull up resistor support option
 - Data rate up to 400 kbps.
 - Configurable I²C addressing
- Industrial Temperature Range: –40°C to +85°C
- Available in 8-Pin SOIC Package

2. Overview

The CapSense Express™ controllers support two capacitive sensing (CapSense) buttons and two general purpose outputs in CY8C20121 and one CapSense button and one general purpose output in CY8C20111. The device functionality is configured through the I²C port and can be stored in on-board nonvolatile memory for automatic loading at power on. The digital outputs are controlled from CapSense inputs in factory default settings, but are user configurable for direct control through I²C.

The four key blocks that make up the CY8C20111 and CY8C20121 controllers are: a robust capacitive sensing core with high immunity against radiated and conductive noise, control registers with nonvolatile storage, configurable outputs, and I²C communications. The user can configure registers with parameters needed to adjust the operation and sensitivity of the CapSense buttons and outputs and permanently store the settings. The standard I²C serial communication interface allows the host to configure the device and read sensor information in real time. I²C address is fully configurable without any external hardware strapping.

3. Pinouts

Figure 1. CY8C20111 Pin Diagram - 8 SOIC - 1 Button

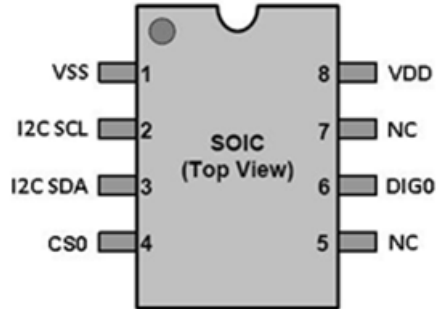

Table 1. Pin Definitions – 8 SOIC- 1 Button

| Pin No | Name | Description |
|--------|---------|------------------------|
| 1 | VSS | Ground |
| 2 | I2C SCL | I ² C Clock |
| 3 | I2C SDA | I ² C Data |
| 4 | CS0 | CapSense Input |
| 5 | NC | No Connect |
| 6 | DIG0 | Digital Output |
| 7 | NC | No Connect |
| 8 | VDD | Supply Voltage |

Figure 2. CY8C20121 Pin Diagram – 8 SOIC- 2 Button

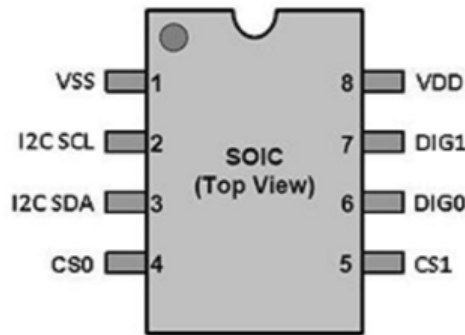
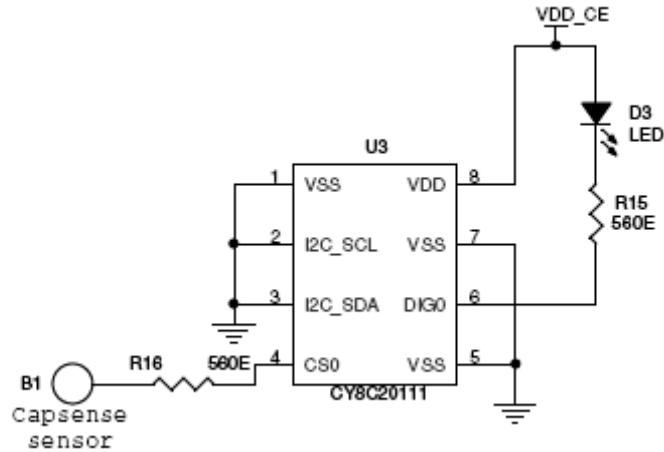

Table 2. Pin Definitions – 8 SOIC- 2 Button

| Pin No | Name | Description |
|--------|---------|------------------------|
| 1 | VSS | Ground |
| 2 | I2C SCL | I ² C Clock |
| 3 | I2C SDA | I ² C Data |
| 4 | CS0 | CapSense Input |
| 5 | CS1 | CapSense Input |
| 6 | DIG0 | Digital Output |
| 7 | DIG1 | Digital Output |
| 8 | VDD | Supply Voltage |

4. Typical Circuits

4.1 Circuit-1: One Button and One LED^[1]



4.2 Circuit-2: One Button and One LED with I²C Interface

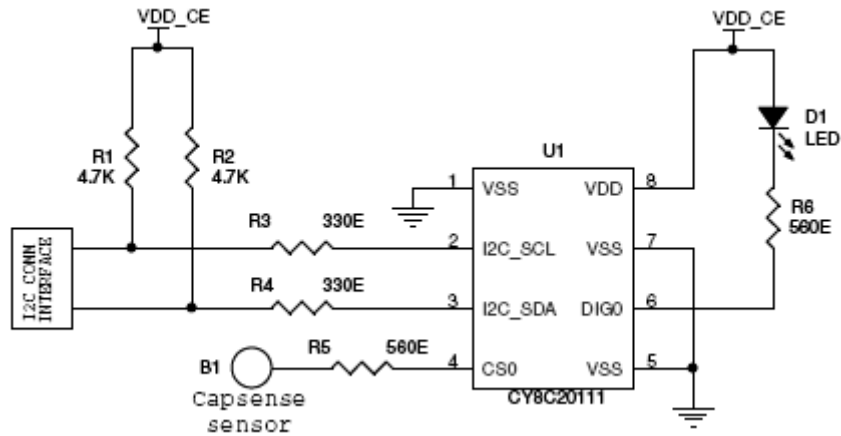

Note

1. The sensors are factory tuned to work with 1 mm plastic or glass overlay.

4.3 Circuit-3: Two Buttons and Two LEDs with I²C Interface

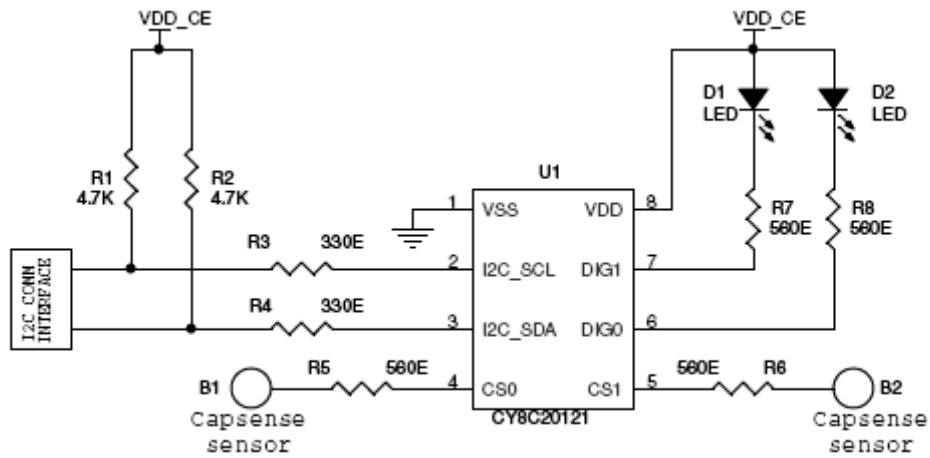

4.4 Circuit-4: Compatibility with 1.8V I²C Signaling^[2]

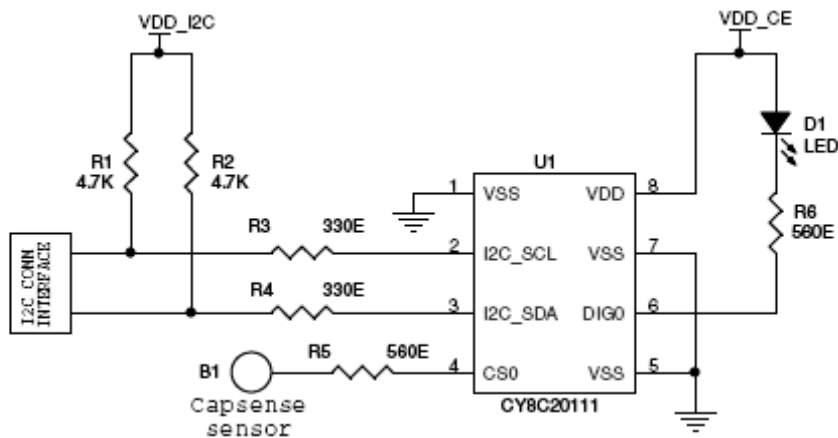

Note

2. $1.8V \leq VDD_I2C \leq VDD_CE$ and $2.4V \leq VDD_CE \leq 5.25V$.

4.5 Circuit-5: Powering Down CapSense Express Device for Low Power Requirements

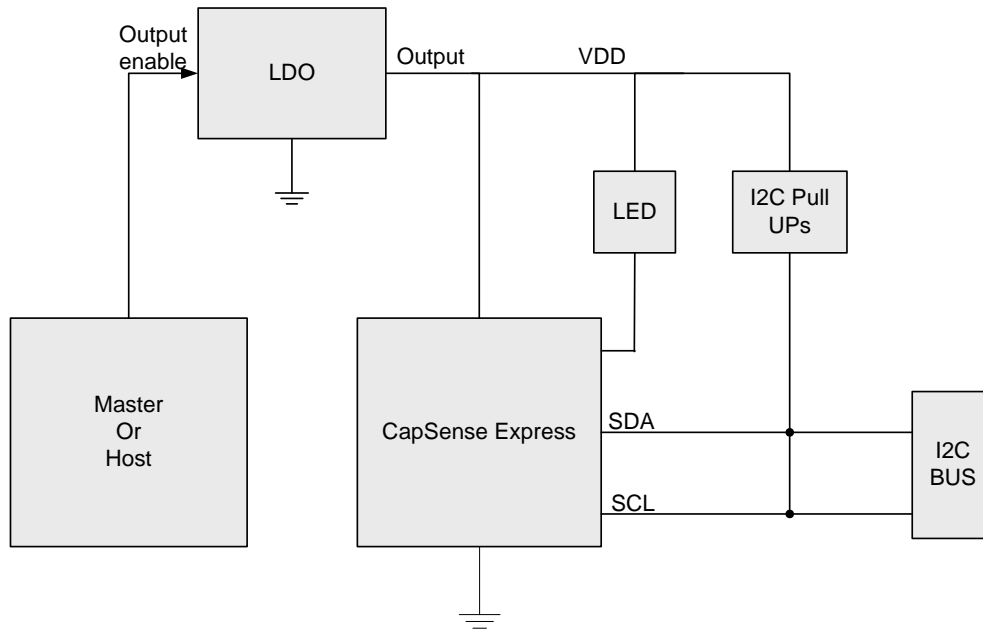

For low power requirements, if Vdd is to be turned off, the above concept can be used. The Vdds of CapSense Express, I²C pull ups, and LEDs must be from the same source. Turning off the Vdd ensures that no signal is applied to the device while it is unpowered. The I²C signals should not be driven high by the master in this situation. If a port pin or group of port pins can cater to the power supply requirement of the circuit, the LDO can be avoided.

5. Operating Modes

5.1 Normal Mode

In normal mode of operation, the acknowledgment time is optimized. The timings remain approximately the same for different configurations of the slave. To reduce the acknowledgment times in normal mode, the registers 0x07, 0x08, 0x11, 0x50, 0x51, 0x5C, 0x5D are given only read access. Writing to these registers can be done only in setup mode.

5.2 Setup Mode

All registers have read and write access (except those which are read only) in this mode. The acknowledgment times are longer compared to normal mode. When CapSense scanning is disabled (command code 0x0A in command register 0xA0), the acknowledgment times can be improved to values similar to the normal mode of operation.

Table 3. I²C Addresses

| 7 Bit Slave Address (in Dec) | D7 | D6 | D5 | D4 | D3 | D2 | D1 | D0 | 8 Bit Slave Address (in Hex) |
|------------------------------|----|----|----|----|----|----|----|------|------------------------------|
| 1 | 0 | 0 | 0 | 0 | 0 | 0 | 1 | 0(W) | 02 |
| 1 | 0 | 0 | 0 | 0 | 0 | 0 | 1 | 1(R) | 03 |
| 75 | 1 | 0 | 0 | 1 | 0 | 1 | 1 | 0(W) | 96 |
| 75 | 1 | 0 | 0 | 1 | 0 | 1 | 1 | 1(W) | 97 |

6. I²C Interface

The CapSense Express devices support the industry standard I²C protocol, which can be used to:

- Configure the device
- Read the status and data registers of the device
- Control device operation
- Execute commands

The I²C address can be modified during configuration.

6.1 I²C Device Addressing

The device uses a seven bit addressing protocol. The I²C data transfer is always initiated by the master sending one byte address; first 7-bit contains address and LSb indicates the data transfer direction. Zero in the LSb indicates the write transaction form master and one indicates read transfer by the master. Table 3 shows example for different I²C addresses.

6.2 I²C Clock Stretching

“Clock stretching” or “bus stalling” in I²C communication protocol is a state in which the slave holds the SCL line low to indicate that it is busy. In this condition, the master is expected to wait until the SCL is released by the slave.

When an I²C master communicates with the CapSense Express device, the CapSense Express stalls the I²C bus after the reception of each byte (that is, just before the ACK/NAK bit) until processing of the byte is complete and critical internal functions are executed. Use a fully I²C compliant master to communicate with the CapSense Express device.

An I²C master which does not support clock stretching (a bit banded software I²C Master) must wait for a specific amount of time specified (as shown in the section [Format for Register Write and Read](#)) for each register write and read operation before the next bit is transmitted. It is mandatory to check the SCL status (it should be high) before I²C master initiates any data transfer with CapSense Express. If the master fails to do so and continues to communicate, the communication is erroneous.

The following diagrams represent the ACK time delays shown in the [Register Map](#) on page 7.

Figure 3. Write ACK Time Representation

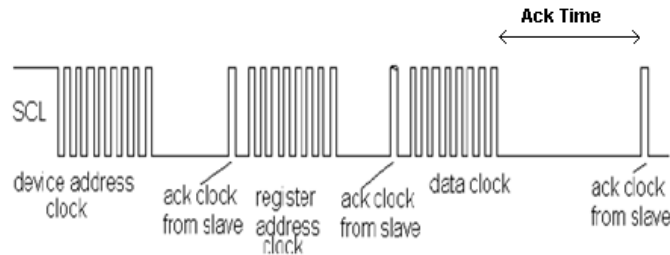
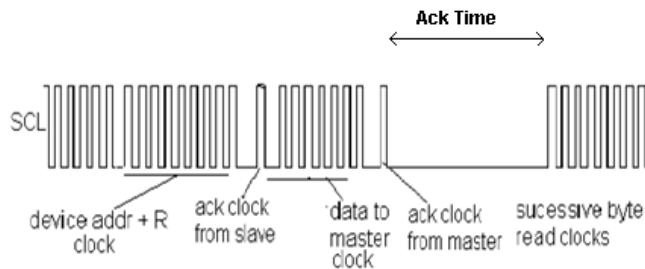
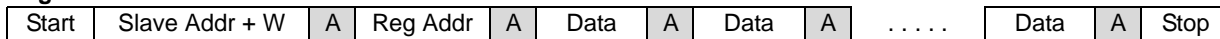

Figure 4. Read ACK Time Representation



6.3 Format for Register Write and Read

Register write format.



Register read format.

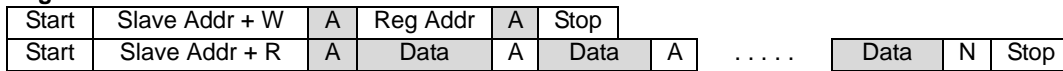

Legends:

| | |
|--------|---------|
| Master | A - ACK |
| Slave | N- NAK |

7. Registers

Table 4. Register Conventions

| Convention | Description |
|------------|--|
| RW | Register have both read and write access |
| R | Register have only read access |
| WPR | Write register with pass code |
| FD | Factory defaults |

Table 5. Register Map

| Name | Register Address (in Hex) | Access | Writable Only in Setup Mode ^[3] | Factory Default Values of Registers (in Hex) | | I ² C Max ACK Time in Normal Mode (ms) ^[5] | I ² C Max ACK Time in Setup Mode (ms) ^[5] | Page No. |
|-----------------------------------|---------------------------|--------|--|--|----------|--|---|----------|
| | | | | 1 Button | 2 Button | | | |
| OUTPUT_PORT | 04 | W | | 01 | 03 | 0.10 | | 9 |
| CS_ENABLE | 07 | RW | Yes | 01 | 03 | | 11 | 9 |
| DIG_ENABLE | 08 | RW | Yes | 01 | 03 | | 11 | 10 |
| SET_STRONG_DM | 11 | RW | Yes | 01 | 03 | | 11 | 10 |
| OP_SEL_0 | 1C | RW | | 82 | 82 | 0.12 | 11 | 12 |
| LOGICAL_OPR_INPUT0 | 1E | RW | | 01 | 01 | 0.12 | 11 | 12 |
| OP_SEL_1 ^[4] | 21 | RW | | | 82 | 0.12 | 11 | 12 |
| LOGICAL_OPR_INPUT1 ^[4] | 23 | RW | | | 02 | 0.12 | 11 | 12 |
| CS_NOISE_TH | 4E | RW | | 28 | 28 | 0.11 | 11 | 13 |
| CS_BL_UPD_TH | 4F | RW | | 64 | 64 | 0.11 | 11 | 13 |
| CS_SETL_TIME | 50 | RW | Yes | A0 | A0 | | 35 | 13 |
| CS_OTH_SET | 51 | RW | Yes | 00 | 00 | | 35 | 14 |
| CS_HYSTERISIS | 52 | RW | | 0A | 0A | 0.11 | 11 | 14 |
| CS_DEBOUNCE | 53 | RW | | 03 | 03 | 0.11 | 11 | 15 |
| CS_NEG_NOISE_TH | 54 | RW | | 14 | 14 | 0.11 | 11 | 15 |
| CS_LOW_BL_RST | 55 | RW | | 14 | 14 | 0.11 | 11 | 15 |
| CS_FILTERING | 56 | RW | | 20 | 20 | 0.11 | 11 | 16 |
| CS_SCAN_POS_0 | 5C | RW | Yes | 00 | 00 | | 11 | 16 |
| CS_SCAN_POS_1 ^[4] | 5D | RW | Yes | | 01 | | 11 | 16 |
| CS_FINGER_TH_0 | 66 | RW | | 64 | 64 | 0.14 | 11 | 17 |
| CS_FINGER_TH_1 ^[4] | 67 | RW | | | 64 | 0.14 | 11 | 17 |
| CS_IDAC_0 | 70 | RW | | 0A | 0A | 0.14 | 11 | 17 |
| CS_IDAC_1 ^[4] | 71 | RW | | | 0A | 0.14 | 11 | 17 |
| I2C_ADDR_LOCK | 79 | RW | | 00 | 00 | 0.11 | 11 | 17 |
| DEVICE_ID | 7A | R | | 11 | 21 | 0.11 | 11 | 18 |
| DEVICE_STATUS | 7B | R | | 03 | 03 | 0.11 | 11 | 18 |
| I2C_ADDR_DM | 7C | RW | | 00 | 00 | 0.11 | 11 | 19 |
| CS_READ_BUTTON | 81 | RW | | 00 | 00 | 0.12 | 11 | 19 |
| CS_READ_BLM | 82 | R | | 00 | 00 | 0.12 | 11 | 20 |
| CS_READ_BLL | 83 | R | | 00 | 00 | 0.12 | 11 | 20 |
| CS_READ_DIFFM | 84 | R | | 00 | 00 | 0.12 | 11 | 20 |
| CS_READ_DIFFL | 85 | R | | 00 | 00 | 0.12 | 11 | 20 |
| CS_READ_RAWM | 86 | R | | 00 | 00 | 0.12 | 11 | 20 |
| CS_READ_RAWL | 87 | R | | 00 | 00 | 0.12 | 11 | 20 |
| CS_READ_STATUS | 88 | R | | 00 | 00 | 0.12 | 11 | 21 |
| COMMAND_REG | A0 | W | | 00 | 00 | 0.10 | 11 | 21 |

Notes

3. These registers are writable only after entering into setup mode. All other registers are available for read and write in normal and setup mode.
4. These registers are available only in CY8C20121 device.
5. The Ack times specified are 1x I2C Ack times.

Table 6. CapSense Express Commands

| Command ^[5] | Description | Executable Mode | Duration the Device is NOT Accessible after ACK (in ms) ^[5] |
|------------------------|------------------------------------|-----------------|--|
| W 00 A0 00 | Get firmware revision | Setup/Normal | 0 |
| W 00 A0 01 | Store current configuration to NVM | Setup/Normal | 120 |
| W 00 A0 02 | Restore factory configuration | Setup/Normal | 120 |
| W 00 A0 03 | Write NVM POR defaults | Setup/Normal | 120 |
| W 00 A0 04 | Read NVM POR defaults | Setup/Normal | 5 |
| W 00 A0 05 | Read current configurations (RAM) | Setup/Normal | 5 |
| W 00 A0 06 | Reconfigure device (POR) | Setup | 5 |
| W 00 A0 07 | Set Normal mode of operation | Setup/Normal | 0 |
| W 00 A0 08 | Set Setup mode of operation | Setup/Normal | 0 |
| W 00 A0 09 | Start scan | Setup/Normal | 10 |
| W 00 A0 0A | Stop scan | Setup/Normal | 5 |
| W 00 A0 0B | Get CapSense scan status | Setup/Normal | 0 |

Note

6. 'W' indicates the write transfer. The next byte of data represents the 7 bit I²C address.

7.1 OUTPUT_PORT

Output Port Register

OUTPUT_PORT: 04h

| 1 Button | 7 | 6 | 5 | 4 | 3 | 2 | 1 | 0 |
|------------|---|---|---|---|---|---|---|--------|
| Access: FD | | | | | | | | W:01 |
| Bit Name | | | | | | | | DIG[0] |

| 2 Button | 7 | 6 | 5 | 4 | 3 | 2 | 1 | 0 |
|------------|---|---|---|---|---|---|----------|---|
| Access: FD | | | | | | | W:03 | |
| Bit Name | | | | | | | DIG[1:0] | |

This register is used to write data to DIG output port. Pins defined as output of combinational logic (in OP_SEL_x register) cannot be changed using this register.

| Bit | Name | Description |
|-----|-----------|--|
| 1:0 | DIG [1:0] | A bit set in this register sets the logic level of the output. 0 Logic '0' 1 Logic '1' |

7.2 CS_ENABLE

Select CapSense Input Register

CS_ENABLE: 07h

(Writable only in Setup mode)

| 1 Button | 7 | 6 | 5 | 4 | 3 | 2 | 1 | 0 |
|------------|---|---|---|---|---|---|---|-------|
| Access: FD | | | | | | | | RW:01 |
| Bit Name | | | | | | | | CS[0] |

| 2 Button | 7 | 6 | 5 | 4 | 3 | 2 | 1 | 0 |
|------------|---|---|---|---|---|---|---------|---|
| Access: FD | | | | | | | RW:03 | |
| Bit Name | | | | | | | CS[1:0] | |

This register is used to enable CapSense inputs. **This register should be set before setting finger threshold (0x66, 0x67) and IDAC setting (0x70, 0x71) registers.**

| Bit | Name | Description |
|-----|----------|---|
| 1:0 | CS [1:0] | These bits are used to enable CapSense inputs. 0 Disable CapSense input 1 Enable CapSense input |

7.3 DIG_ENABLE

Select DIG Output Register

GPO_ENABLE: 08h

(Writable only in Setup mode)

| | | | | | | | | |
|-----------------|----------|----------|----------|----------|----------|----------|----------|----------|
| 1 Button | 7 | 6 | 5 | 4 | 3 | 2 | 1 | 0 |
| Access: FD | | | | | | | | RW:01 |
| Bit Name | | | | | | | | DIG[0] |

| | | | | | | | | |
|-----------------|----------|----------|----------|----------|----------|----------|-----------|----------|
| 2 Button | 7 | 6 | 5 | 4 | 3 | 2 | 1 | 0 |
| Access: FD | | | | | | | RW:03 | |
| Bit Name | | | | | | | DIG [1:0] | |

This register is used to enable DIG (Digital) outputs. If DIG output is enabled, the strong drive mode register (11h) should also be set. If DIG output is disabled the drive mode of these pins is High Z.

| Bit | Name | Description |
|-----|-----------|--|
| 1:0 | DIG [1:0] | These bits are used to enable DIG outputs. |
| | | 0 Disable DIG output |
| | | 1 Enable DIG output |

7.4 SET_STRONG_DM

Sets Strong Drive Mode for DIG Outputs.

SET_STRONG_DM: 11h

(Writable only in Setup mode)

| | | | | | | | | |
|-----------------|----------|----------|----------|----------|----------|----------|----------|----------|
| 1 Button | 7 | 6 | 5 | 4 | 3 | 2 | 1 | 0 |
| Access: FD | | | | | | | | RW:01 |
| Bit Name | | | | | | | | DM [0] |

| | | | | | | | | |
|-----------------|----------|----------|----------|----------|----------|----------|----------|----------|
| 2 Button | 7 | 6 | 5 | 4 | 3 | 2 | 1 | 0 |
| Access: FD | | | | | | | RW:03 | |
| Bit Name | | | | | | | DM [1:0] | |

This register sets strong drive mode for DIG (Digital) outputs. To set strong drive mode the pin should be enabled as GP output.

| Bit | Name | Description |
|-----|----------|--|
| 1:0 | DM [1:0] | These bits are used to set the strong drive mode to DIG outputs. |
| | | 0 Strong drive mode not set |
| | | 1 Strong drive mode set |

Figure 5. CY8C20111 Digital Logic Diagram

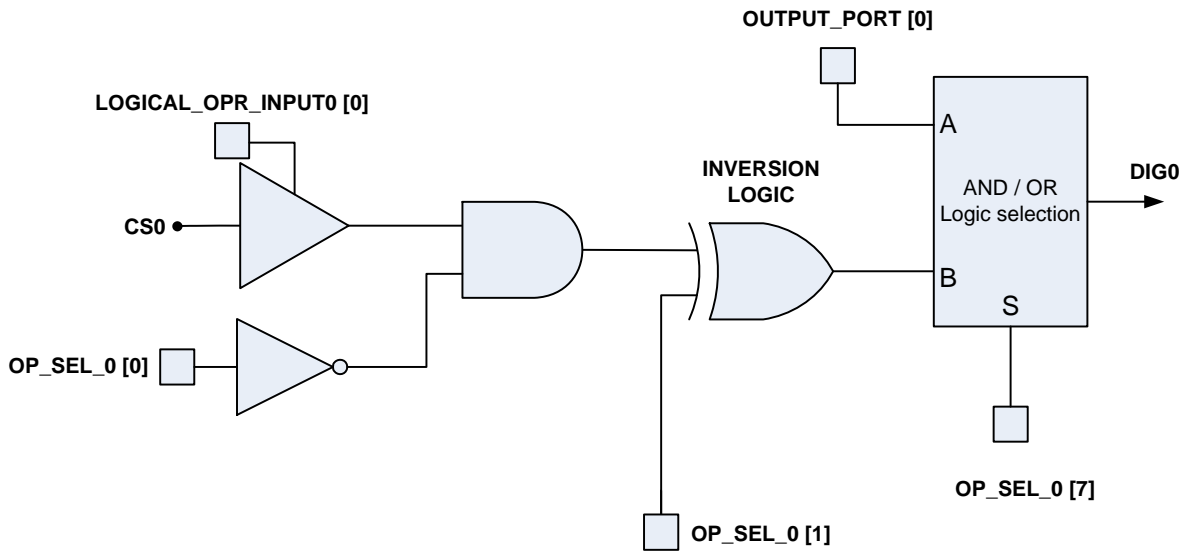
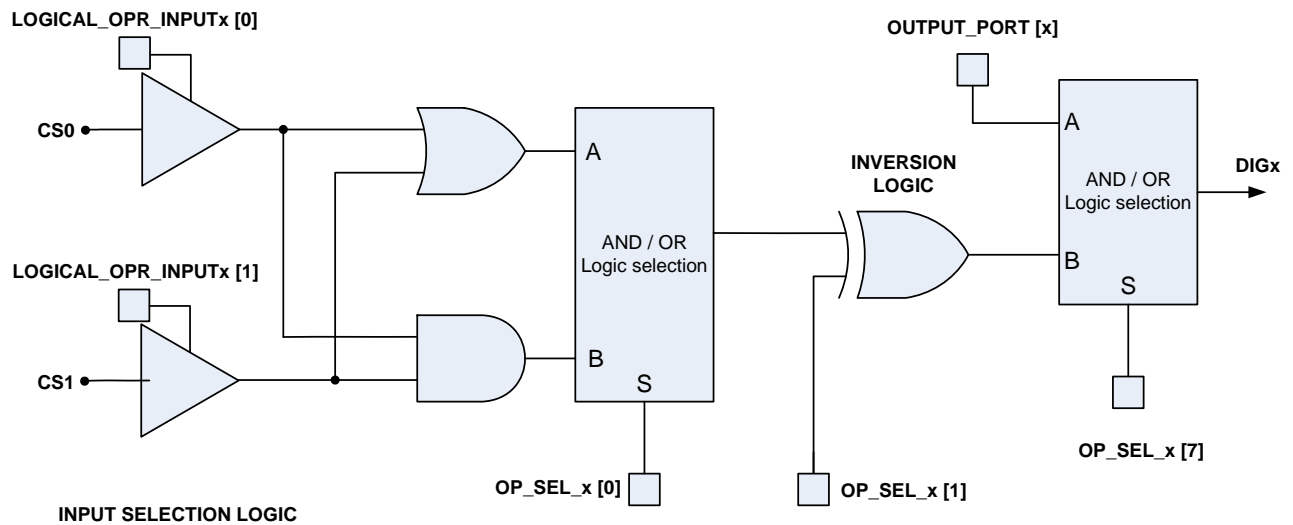

Figure 6. CY8C20121 Digital Logic Diagram



7.5 OP_SEL_x

Logic Operation Selection Registers

OP_SEL_0: 1Ch OP_SEL_1: 21h (Not available for 1 Button)

| 1/2Button | 7 | 6 | 5 | 4 | 3 | 2 | 1 | 0 |
|------------|-------|---|---|---|---|---|-------|----------|
| Access: FD | RW: 0 | | | | | | RW: 0 | RW: 0 |
| Bit Name | Op_En | | | | | | InvOp | Operator |

This register is used to enable logic operation on GP outputs. OP_SEL_0 should be configured to get the logic operation output on DIG0 output and OP_SEL_1 for DIG1 output. Write to these registers during the disable state of respective DIG output pins does not have any effect.

The input to the logic operation can be selected in LOGIC_OPRX registers. The selected inputs can be ORed or ANDed. The output of logic operation can also be inverted.

| Bit | Name | Description |
|-----|----------|---|
| 7 | Op_En | This bit enables or disables logic operation. 0 Disable logic operation 1 Enable logic operation |
| 1 | InvOp | This bit enables or disables logic operation output inversion. 0 Logic operation output not inverted 1 Logic operation output inverted |
| 0 | Operator | This bit selects which operator should be used to compute logic operation. 0 Logic operator OR is used on inputs 1 Logic operator AND is used on inputs |

7.6 LOGICAL_OPR_INPUTx

Selects Input for Logic Operation

LOGICAL_OPR_INPUT0: 1Eh LOGICAL_OPR_INPUT1: 23h (Not available for 1 button)

LOGICAL_OPR_INPUT0

| 1 Button | 7 | 6 | 5 | 4 | 3 | 2 | 1 | 0 |
|------------|---|---|---|---|---|---|---|--------|
| Access: FD | | | | | | | | RW:01 |
| Bit Name | | | | | | | | CSL[0] |

| 2 Button | 7 | 6 | 5 | 4 | 3 | 2 | 1 | 0 |
|------------|---|---|---|---|---|---|---|-----------|
| Access: FD | | | | | | | | RW:01 |
| Bit Name | | | | | | | | CSL [1:0] |

LOGICAL_OPR_INPUT1

| 2 Button | 7 | 6 | 5 | 4 | 3 | 2 | 1 | 0 |
|------------|---|---|---|---|---|---|---|-----------|
| Access: FD | | | | | | | | RW:02 |
| Bit Name | | | | | | | | CSL [1:0] |

These registers are used to give the input to logic operation block. The inputs can be only CapSense input status.

| Bit | Name | Description |
|-----|-----------|---|
| 1:0 | CSL [1:0] | These bits selects the input for logic operation block. |

7.7 CS_NOISE_TH

Noise Threshold Register

CS_NOISE_TH: 4Eh

| 1/2 Button | 7 | 6 | 5 | 4 | 3 | 2 | 1 | 0 |
|------------|---------|---|---|---|---|---|---|---|
| Access: FD | RW:28 | | | | | | | |
| Bit Name | NT[7:0] | | | | | | | |

This register sets the noise threshold value. For individual sensors, count values above this threshold do not update the baseline. This count is relative to baseline. This parameter is common for all sensors.

The range is 3 to 255 and it should satisfy the equation $NT < \text{Min}(\text{Finger Threshold} - \text{Hysteresis} - 5)$. Recommended value is 40% of finger threshold.

| Bit | Name | Description |
|-----|----------|---|
| 7:0 | NT [7:0] | These bits are used to set the noise threshold value. |

7.8 CS_BL_UPD_TH

Baseline Update Threshold Register

CS_BL_UPD_TH: 4Fh

| 1/2 Button | 7 | 6 | 5 | 4 | 3 | 2 | 1 | 0 |
|------------|-----------|---|---|---|---|---|---|---|
| Access: FD | RW:64 | | | | | | | |
| Bit Name | BLUT[7:0] | | | | | | | |

When the new raw count value is above the current baseline and the difference is below the noise threshold, the difference between the current baseline and the raw count is accumulated into a “bucket.” When the bucket fills, the baseline increments and the bucket is emptied. This parameter sets the threshold that the bucket must reach for the baseline to increment. In other words, lower value provides faster baseline update rate and vice versa. This parameter is common for all sensors.

The range is 0 to 255.

| Bit | Name | Description |
|-----|------------|--|
| 7:0 | BLUT [7:0] | These bits set the threshold that the bucket must reach for baseline to increment. |

7.9 CS_SETL_TIME

Settling Time Register

CS_SETL_TIME: 50h

(Writable only in Setup mode)

| 1/2 Button | 7 | 6 | 5 | 4 | 3 | 2 | 1 | 0 |
|------------|---------------|---|---|---|---|---|---|---|
| Access: FD | RW:A0 | | | | | | | |
| Bit Name | STLNG_TM[7:0] | | | | | | | |

The settling time parameter controls the duration of the capacitance-to-voltage conversion phase. The parameter setting controls a software delay that allows the voltage on the integrating capacitor to stabilize. This parameter is common for all sensors.

This register should be set before setting finger threshold (0x66, 0x67) and IDAC setting (0x70, 0x71) registers.

The range is 2 to 255.

| Bit | Name | Description |
|-----|----------------|---|
| 7:0 | STLNG_TM [7:0] | These bits are used to set the settling time value. |

7.10 CS_OTH_SET

CapSense Clock Select, Sensor Auto Reset Register

CS_OTH_SET: 51h

(Writable only in Setup mode)

| 1/2 Button | 7 | 6 | 5 | 4 | 3 | 2 | 1 | 0 |
|------------|---|-------------|---|---|--------|---|---|---|
| Access: FD | | RW: 00 | | | RW: 0 | | | |
| Bit Name | | CS_CLK[1:0] | | | Sns_Ar | | | |

The registers set the CapSense module frequency of operation and enables or disables the sensor auto reset.

CS_CLK bits provides option to select variable clock input for the CapSense block. A sensor design having higher paratactic requires lower clock for better performance and vice versa.

Sensor Auto Reset determines whether the baseline is updated at all times or only when the signal difference is below the noise threshold. When set to '1' (enabled), the baseline is updated constantly. This setting limits the maximum time duration of the sensor, but it prevents the sensors from permanently turning on when the raw count suddenly rises without anything touching the sensor. This sudden rise can be caused by a large power supply voltage fluctuation, a high energy RF noise source, or a very quick temperature change. When the parameter is set to '0' (disabled), the baseline is updated only when raw count and baseline difference is below the noise threshold parameter. This parameter may be enabled unless there is a demand to keep the sensors in the on state for a long time. This parameter is common for all sensors.

| Bit | Name | Description | | | | | | | | | | |
|-------------|------------------------|---|-------------|------------------------|----|-----|----|-------|----|-------|----|-------|
| 6:5 | CS_CLK[1:0] | These bits selects the CapSense clock. | | | | | | | | | | |
| | | <table border="1"> <thead> <tr> <th>CS_CLK[1:0]</th> <th>Frequency of Operation</th> </tr> </thead> <tbody> <tr> <td>00</td> <td>IMO</td> </tr> <tr> <td>01</td> <td>IMO/2</td> </tr> <tr> <td>10</td> <td>IMO/4</td> </tr> <tr> <td>11</td> <td>IMO/8</td> </tr> </tbody> </table> | CS_CLK[1:0] | Frequency of Operation | 00 | IMO | 01 | IMO/2 | 10 | IMO/4 | 11 | IMO/8 |
| CS_CLK[1:0] | Frequency of Operation | | | | | | | | | | | |
| 00 | IMO | | | | | | | | | | | |
| 01 | IMO/2 | | | | | | | | | | | |
| 10 | IMO/4 | | | | | | | | | | | |
| 11 | IMO/8 | | | | | | | | | | | |
| 3 | Sns_Ar | <p>This bit is used to enable or disable sensor auto reset.</p> <p>0 Disable Sensor auto reset</p> <p>1 Enable Sensor auto reset</p> | | | | | | | | | | |

7.11 CS_HYSTERISIS

Hysteresis Register

CS_HYSTERISIS: 52h

| 1/2 Button | 7 | 6 | 5 | 4 | 3 | 2 | 1 | 0 |
|------------|----------|---|---|---|---|---|---|---|
| Access: FD | RW:0A | | | | | | | |
| Bit Name | HYS[7:0] | | | | | | | |

The Hysteresis parameter adds to or subtracts from the finger threshold depending on whether the sensor is currently active or inactive. If the sensor is off, the difference count must overcome the 'finger threshold + hysteresis'. If the sensor is on, the difference count must go below the 'finger threshold – hysteresis'. It is used to add debouncing and "stickiness" to the finger detection algorithm. This parameter is common for all sensors.

Possible values are 0 to 255. However, the setting must be lower than the finger threshold parameter setting. Recommended value for hysteresis is 15 percent of finger threshold.

| Bit | Name | Description |
|-----|-----------|--|
| 7:0 | HYS [7:0] | These bits are used to set the hysteresis value. |

7.12 CS_DEBOUNCE

Debounce Register.

CS_DEBOUNCE: 53h

| | | | | | | | | |
|-------------------|----------|----------|----------|----------|----------|----------|----------|----------|
| 1/2 Button | 7 | 6 | 5 | 4 | 3 | 2 | 1 | 0 |
| Access: FD | RW:0A | | | | | | | |
| Bit Name | DB[7:0] | | | | | | | |

The Debounce parameter adds a debounce counter to the 'sensor active transition'. For the sensor to transition from inactive to active, the consecutive samples of difference count value must stay above the 'finger threshold + hysteresis' for the number specified. This parameter is common for all sensors.

Possible values are 1 to 255. A setting of '1' provides no debouncing.

| Bit | Name | Description |
|-----|----------|--|
| 7:0 | DB [7:0] | These bits are used to set the debounce value. |

7.13 CS_NEG_NOISE_TH

Negative Noise Threshold Register

CS_NEG_NOISE_TH: 54h

| | | | | | | | | |
|-------------------|----------|----------|----------|----------|----------|----------|----------|----------|
| 1/2 Button | 7 | 6 | 5 | 4 | 3 | 2 | 1 | 0 |
| Access: FD | RW:0A | | | | | | | |
| Bit Name | NNT[7:0] | | | | | | | |

This parameter adds a negative difference count threshold. If the current raw count is below the baseline and the difference between them is greater than this threshold, the baseline is not updated. However, if the current raw count stays in the low state (difference greater than the threshold) for the number of samples specified by the Low Baseline Reset parameter, the baseline is reset. This parameter is common for all sensors.

| Bit | Name | Description |
|-----|-----------|--|
| 7:0 | NNT [7:0] | These bits are used to set the negative noise value. |

7.14 CS_LOW_BL_RST

Low Baseline Reset Register

CS_LOW_BL_RST: 55h

| | | | | | | | | |
|-------------------|----------|----------|----------|----------|----------|----------|----------|----------|
| 1/2 Button | 7 | 6 | 5 | 4 | 3 | 2 | 1 | 0 |
| Access: FD | RW:0A | | | | | | | |
| Bit Name | LBR[7:0] | | | | | | | |

This parameter works together with the Negative Noise Threshold parameter. If the sample count values are below the baseline minus the negative noise threshold for the specified number of samples, the baseline is set to the new raw count value. It essentially counts the number of abnormally low samples required to reset the baseline. It is generally used to correct the finger-on-at-startup condition. This parameter is common for all sensors.

| Bit | Name | Description |
|-----|-----------|--|
| 7:0 | LBR [7:0] | These bits are used to set the Low Baseline Reset value. |

7.15 CS_FILTERING

CapSense Filtering Register

CS_FILTERING: 56h

| | | | | | | | | |
|-------------------|----------|----------|----------|----------|----------|----------|----------------|----------|
| 1/2 Button | 7 | 6 | 5 | 4 | 3 | 2 | 1 | 0 |
| Access: FD | RW: 0 | | RW: 1 | RW: 0 | | | RW: 00 | |
| Bit Name | RstBl | | I2C_DS | Avg_En | | | Avg_Order[1:0] | |

This register provides an option for forced baseline reset and to enable and configure two different types of software filters.

| Bit | Name | Description |
|-------|----------------|--|
| 7 | RstBl | This bit resets all the baselines and it is auto cleared to '0'. 0 All Baselines are not reset 1 All baselines are reset |
| 5 | I2C_DS | When this bit is set to '1' the CapSense scan sample is dropped if I ² C communication was active during scanning. 0 Disable the I ² C drop sample filter 1 Enable the I ² C drop sample filter |
| 4 | Avg_En | This bit enables average filter on raw counts. 0 Disable the average filter 1 Enable the average filter |
| [1:0] | Avg_Order[1:0] | These bits are used to select the number of CapSense samples to average: |

| Avg_Order[1:0] in Hex | Samples to Average |
|-----------------------|--------------------|
| 00 | 2 |
| 01 | 4 |
| 10 | 8 |
| 11 | 16 |

7.16 CS_SCAN_POS_x

Scan Position Registers

CS_SCAN_POS_0: 5Ch

(Writable only in Setup mode)

| | | | | | | | | |
|-------------------|----------|----------|----------|----------|----------|----------|----------|-----------|
| 1/2 Button | 7 | 6 | 5 | 4 | 3 | 2 | 1 | 0 |
| Access: FD | | | | | | | | RW: 0 |
| Bit Name | | | | | | | | Scan_Pstn |

CS_SCAN_POS_1: 5Dh (Not available for 1 Button)

(Writable only in Setup mode)

| | | | | | | | | |
|-----------------|----------|----------|----------|----------|----------|----------|----------|-----------|
| 2 Button | 7 | 6 | 5 | 4 | 3 | 2 | 1 | 0 |
| Access: FD | | | | | | | | RW: 1 |
| Bit Name | | | | | | | | Scan_Pstn |

This register is used to set the position of the sensors in the switch table for proper scanning sequence because the CapSense sensors are scanned in sequence.

This register should be set after setting 0x07, 0x50, and 0x51 registers.

| Bit | Name | Description |
|-----|-----------|----------------------------------|
| 0 | Scan_Pstn | This bit sets the scan position. |

7.17 CS_FINGER_TH_x

Finger Threshold Registers

CS_FINGER_TH_0: 66h CS_FINGER_TH_1: 67h (Not available in 1 Button)

| | | | | | | | | |
|-------------------|----------|----------|----------|----------|----------|----------|----------|----------|
| 1/2 Button | 7 | 6 | 5 | 4 | 3 | 2 | 1 | 0 |
| Access: FD | RW: 64 | | | | | | | |
| Bit Name | FT[7:0] | | | | | | | |

This register sets the finger threshold value for CapSense inputs. Possible values are 3 to 255. This parameter should be configured individually for each CapSense inputs.

This register should be set after setting 0x07, 0x50, and 0x51 registers.

| Bit | Name | Description |
|-------|----------|---|
| [7:0] | FT [7:0] | These bit set the finger threshold for CapSense inputs. |

7.18 CS_IDAC_x

IDAC Setting Registers

CS_IDAC_0: 70h CS_IDAC_1: 71h (Not available in 1 Button)

| | | | | | | | | |
|-------------------|-----------|----------|----------|----------|----------|----------|----------|----------|
| 1/2 Button | 7 | 6 | 5 | 4 | 3 | 2 | 1 | 0 |
| Access: FD | RW: 0A | | | | | | | |
| Bit Name | IDAC[7:0] | | | | | | | |

The IDAC register controls the sensitivity of the CapSense algorithm. This register is used to tune the CapSense input for specific design or overlays. Decreasing the value of this register increases the sensitivity of the CapSense buttons and vice versa. Decreasing the value of IDAC increases noise and vice versa.

Possible values are 1 to 255. If the value is set to 0 then the value is reset to default value 10.

The recommended value is greater than 4. Setting value ≤ 4 creates excessive amount of noise.

This register should be set after setting 0x07, 0x50, and 0x51 registers.

| Bit | Name | Description |
|-------|------------|--------------------------------|
| [7:0] | IDAC [7:0] | These bit set the IDAC values. |

7.19 I2C_ADDR_LOCK

I2C Address Lock Registers

I2C_ADDR_LOCK: 79h

| | | | | | | | | |
|-------------------|----------|----------|----------|----------|----------|----------|----------|----------|
| 1/2 Button | 7 | 6 | 5 | 4 | 3 | 2 | 1 | 0 |
| Access: FD | | | | | | | | WPR: 0 |
| Bit Name | | | | | | | | I2CAL |

This register is used to unlock and lock the I²C address register (7Ch) access. The device I²C address should be modified by writing new address to register 7Ch after unlocking the access using this register. Write to the 7C register during the locked state does not have any effect and the new address take effect only after the access is locked.

To lock or unlock the I²C AL bit, the following three bytes must be written to register 79h:

- unlock I2CAL: 3Ch A5h 69h
- lock I2CAL: 96h 5Ah C3h

Reading the I2CAL bit from register 79h indicates the current access state.

| Bit | Name | Description |
|-----|-------|--|
| 0 | I2CAL | This bit gives the lock/unlock status of I ² C address. |
| | | 0 Unlocked |
| | | 1 Locked |

7.20 DEVICE_ID

Device ID Register

DEVICE_ID: 7Ah

| 1 Button | 7 | 6 | 5 | 4 | 3 | 2 | 1 | 0 |
|------------|-------------|---|---|---|---|---|---|---|
| Access: FD | R: 11 | | | | | | | |
| Bit Name | DEV_ID[7:0] | | | | | | | |

| 2 Button | 7 | 6 | 5 | 4 | 3 | 2 | 1 | 0 |
|------------|-------------|---|---|---|---|---|---|---|
| Access: FD | R: 21 | | | | | | | |
| Bit Name | DEV_ID[7:0] | | | | | | | |

This register contains the device and product ID. The device and product ID corresponds to “xx” in CY8C201xx.

| Bit | Name | Description |
|-----|--------------|---|
| 7:0 | DEV_ID [7:0] | These bits contain the device and product ID. |

| Part No | Device/Product ID |
|-----------|-------------------|
| CY8C20111 | 11 |
| CY8C20121 | 21 |

7.21 DEVICE_STATUS

Device Status Register

DEVICE_STATUS: 7Bh

| 1/2 Button | 7 | 6 | 5 | 4 | 3 | 2 | 1 | 0 |
|------------|--------------|---|------|---------|-----------|---|------|------|
| Access: FD | R : 00 | | R: 0 | R : 0 | R: 0 | | R: 0 | R: 0 |
| Bit Name | Ip_Volt[1:0] | | IRES | Load_FD | No_NVM_Wr | | CSE | DIGE |

This register contains the device status.

| Bit | Name | Description |
|-----|---------------|--|
| 7:6 | Ip_Volt [1:0] | Supply voltage is automatically detected and these bits are set accordingly. |

| Ip_Volt[1:0] | Supply Voltage |
|--------------|----------------|
| 00 | 5 |
| 01 | 3.3 |
| 10 | 2.7 |
| 11 | Reserved |

| | | |
|---|-----------|--|
| 5 | IRES | When set to '1', this bit indicates that an internal reset occurred. 0 indicates the last system reset was not internal reset 1 indicates the last system reset was internal reset |
| 4 | Load_FD | This bit indicates whether factory defaults are loaded during power up. 0 User default configuration is loaded during power up 1 Factory default configuration is loaded during power up |
| 3 | No_NVM_Wr | When set to '1', this bit indicates that the supply voltage applied to the device is too low for a write to nonvolatile memory operation, and no write is performed. This bit must be checked before any Store or Write POR command. |
| 1 | CSE | This bit indicates whether CapSense function is enabled or disabled. 0 Functionality of CapSense block is disabled 1 Functionality of CapSense block is enabled |
| 0 | DIGE | This bit indicates whether GP Output function is enabled or disabled. 0 Functionality of Digital output block is disabled 1 Functionality of Digital output block is enabled |

7.22 I2C_ADDR_DM

Device I²C Address and I²C Pin Drive Mode Register

I2C_ADDR_DM: 7Ch

| | | | | | | | | |
|-----------------|----------|---------------|----------|----------|----------|----------|----------|----------|
| 1 Button | 7 | 6 | 5 | 4 | 3 | 2 | 1 | 0 |
| Access: FD | RW: 0 | RW: 00 | | | | | | |
| Bit Name | I2CIP_EN | I2C_ADDR[6:0] | | | | | | |

This register sets the drive mode of I²C pins and I²C slave address. To write to this register, register 79h must first be unlocked. The value written to register 7Ch is applied only after locking register 79h again.

| Bit | Name | Description |
|-----|----------------|--|
| 7 | I2CIP_EN | This bit is used to set the I ² C pins drive mode. 0 Internal pull up enabled 1 Internal pull up disabled |
| 6:0 | I2C_ADDR [6:0] | Used to set the device I ² C address. |

7.23 CS_READ_BUTTON

Button Select Register

I2C_ADDR_DM: 81h

| | | | | | | | | |
|-----------------|----------|----------|----------|----------|----------|----------|----------|----------|
| 1 Button | 7 | 6 | 5 | 4 | 3 | 2 | 1 | 0 |
| Access: FD | RW: 0 | | | | | | | RW: 0 |
| Bit Name | RD_EN | | | | | | | CSBN[0] |

| | | | | | | | | |
|-----------------|----------|----------|----------|----------|----------|----------|-----------|----------|
| 2 Button | 7 | 6 | 5 | 4 | 3 | 2 | 1 | 0 |
| Access: FD | RW: 0 | | | | | | RW: 00 | |
| Bit Name | RD_EN | | | | | | CSBN[1:0] | |

The scan result of a CapSense input (raw count, difference count, and baseline) can be read only for one input at a time using 82h-87h registers. This register is used to select a CapSense input to read the raw count, difference count, and baseline. Only the pins defined as CapSense inputs in register 07h can be used with this register. Trying to select other pins not defined as CapSense does not have any change.

| Bit | Name | Description |
|-----|------------|---|
| 7 | RD_EN | This bit enables the CapSense raw data reading. 0 Disable CapSense scan result reading 1 Enable CapSense scan result reading |
| 1:0 | CSBN [1:0] | These bits decide which CapSense button scan result are read. When writing to this register, the bitmask must contain only one bit set to '1', otherwise the data is discarded. |

| CSBN [1:0] | CapSense Button No |
|------------|--------------------|
| 01 | 1 |
| 10 | 2 |

7.24 CS_READ_BLx

Baseline Value MSB/LSB Registers

CS_READ_BLM: 82h CS_READ_BLL: 83h

| | | | | | | | | |
|-------------------|----------|----------|----------|----------|----------|----------|----------|----------|
| 1/2 Button | 7 | 6 | 5 | 4 | 3 | 2 | 1 | 0 |
| Access: FD | R: 00 | | | | | | | |
| Bit Name | BL [7:0] | | | | | | | |

Reading from this register returns the 2-byte current baseline value for the selected CapSense input.

| Bit | Name | Description |
|------------|-------------|--|
| 7:0 | BL [7:0] | These bits represent the baseline value. |

7.25 CS_READ_DIFFx

Difference Count Value MSB/LSB Registers

CS_READ_DIFFM: 82h CS_READ_DIFFL: 83h

| | | | | | | | | |
|-------------------|-----------|----------|----------|----------|----------|----------|----------|----------|
| 1/2 Button | 7 | 6 | 5 | 4 | 3 | 2 | 1 | 0 |
| Access: FD | R: 00 | | | | | | | |
| Bit Name | DIF [7:0] | | | | | | | |

Reading from this register returns the 2-byte current difference count for the selected CapSense input.

| Bit | Name | Description |
|------------|-------------|---|
| 7:0 | DIF [7:0] | These bits represent the sensor difference count. |

7.26 CS_READ_RAWx

Difference Count Value MSB/LSB Registers

CS_READ_RAWM: 82h CS_READ_RAWL: 83h

| | | | | | | | | |
|-------------------|----------|----------|----------|----------|----------|----------|----------|----------|
| 1/2 Button | 7 | 6 | 5 | 4 | 3 | 2 | 1 | 0 |
| Access: FD | R: 00 | | | | | | | |
| Bit Name | RC [7:0] | | | | | | | |

Reading from this register returns the 2-byte current raw count value for the selected CapSense input.

| Bit | Name | Description |
|------------|-------------|---|
| 7:0 | RC [7:0] | These bits represent the raw count value. |

7.27 CS_READ_STATUS

Sensor On Status Register

CS_READ_STATUS: 88h

| | | | | | | | | |
|-----------------|----------|----------|----------|----------|----------|----------|----------|----------|
| 1 Button | 7 | 6 | 5 | 4 | 3 | 2 | 1 | 0 |
| Access: FD | | | | | | | | R: 0 |
| Bit Name | | | | | | | | BT_ST[0] |

| | | | | | | | | |
|-----------------|----------|----------|----------|----------|----------|----------|------------|----------|
| 2 Button | 7 | 6 | 5 | 4 | 3 | 2 | 1 | 0 |
| Access: FD | | | | | | | R: 00 | |
| Bit Name | | | | | | | BT_ST[1:0] | |

This register gives the sensor ON/OFF status. A bit '1' indicates sensor is ON and '0' indicates sensor is OFF.

| Bit | Name | Description |
|-----|-------------|--|
| 1:0 | BT_ST [1:0] | These bits used to represent sensor status. 0 Sensor OFF 1 Sensor ON |

7.28 COMMAND_REG

Command Register

COMMAND_REG: A0h

| | | | | | | | | |
|-------------------|----------|----------|----------|----------|----------|----------|----------|------------|
| 1/2 Button | 7 | 6 | 5 | 4 | 3 | 2 | 1 | 0 |
| Access: FD | | | | | | | | W: 00 |
| Bit Name | | | | | | | | Cmnd [7:0] |

Commands are executed by writing the command code to the command register.

| Bit | Name | Description |
|-----|------------|--|
| 7:0 | Cmnd [7:0] | Refer to the following table for command register opcodes. |

| Command Code | Name | Description |
|--------------|------------------------------------|---|
| 00h | Get Firmware Revision | The I ² C buffer is loaded with the one byte firmware revision value. Reading one byte after writing this command returns the firmware revision. The upper nibble of the firmware revision byte is the major revision number and the lower nibble is the minor revision number. |
| 01h | Store Current Configuration to NVM | The current register settings are saved in nonvolatile memory (Flash). This setting is automatically loaded after the next device reset/power up or if the Reconfigure Device (06h) command is issued. |
| 02h | Restore Factory Configuration | Replaces the saved user configuration with the factory default configuration. Current settings are unaffected by this command. New settings are loaded after the next device reset/power up or if the 06h command is issued. |
| 03h | Write POR Defaults | Sends new power up defaults to the CapSense controller without changing current settings unless the 06h command is issued afterwards. This command is followed by 123 data bytes according to the POR Default Data Structure table. The CRC is calculated as the XOR of the 122 data bytes (00h-79h). If the CRC check fails or an incomplete block is sent, the slave responds with an ACK and the data is NOT saved to Flash. To define new POR defaults: <ul style="list-style-type: none"> ■ Write command 03h ■ Write 122 data bytes with new values of registers (use the _flash.iic file generated from s/w tool) ■ Write one CRC byte calculated as XOR of previous 122 data bytes |

| Command Code | Name | Description |
|--------------|----------------------------------|--|
| 04h | Read POR Defaults | <p>Reads the POR settings stored in the nonvolatile memory. To read POR defaults:</p> <ul style="list-style-type: none"> ■ Write command 04h ■ Read 122 data bytes ■ Read one CRC byte |
| 05h | Read Device Configuration (RAM) | <p>Reads the current device configuration. Gives the user "flat-address-space" access to all device settings. To read device configuration:</p> <ul style="list-style-type: none"> ■ Write command 05h ■ Read 122 data bytes ■ Read one CRC byte |
| 06h | Reconfigure Device (POR) | <p>Immediately reconfigures the device with actual POR defaults from Flash. Has the same effect on the registers as a POR. This command can only be executed in setup operation mode (command code 08).</p> |
| 07h | Set Normal Operation Mode | <p>Sets the device in normal operation mode. In this mode, CapSense pin assignments cannot be modified; settling time, IDAC setting, external capacitor, and sensor auto-reset also cannot be modified.</p> |
| 08h | Set Setup Operation Mode | <p>Sets the device in setup operation mode. In this mode, CapSense pin assignments can be changed along with other parameters.</p> |
| 09h | Start CapSense Scanning | <p>Allows the user to start CSA scanning after it has been stopped using command 0x0A. Note that at POR, scanning is enabled and started by default if one or more sensors are enabled.</p> |
| 0Ah | Stop CapSense Scanning | <p>Allows the user to stop CSA scanning. A system host controller might initiate this command before powering down the device to make sure that during power down no CapSense touches are detected. When CSA scanning is stopped by the user and the device is still in the valid VCC operating range, the following behavior is supported:</p> <ul style="list-style-type: none"> ■ Any change to configuration can still be done (as long as VCC is in operating range). ■ Command code 0x06 overrides the status of stop/scan by enabling and starting CSA scanning if one or more sensors are enabled. ■ CapSense read-back values return 0x00. |
| 0Bh | Returns CapSense Scanning Status | <p>The I²C buffer is loaded with the one-byte CSA scanning status value. After writing the value 0Bh to the A0h register, reading one byte returns the CSA scanning status. It returns the LVD_STOP_SCAN and STOP_SCAN bits. LVD_STOP_SCAN is bit 3 - Set when CSA is stopped because VCC is outside the valid operating range. STOP_SCAN is bit 2 - Set when CSA is stopped by the user by writing command 0x0A.</p> |

8. Layout Guidelines and Best Practices

| Sl. No. | Category | Min | Max | Recommendations/Remarks |
|---------|---|---------------------------|---------|--|
| 1 | Button Shape | | | Solid round pattern, round with LED hole, rectangle with round corners |
| 2 | Button Size | 5 mm | 15 mm | 10 mm |
| 3 | Button Button Spacing | = Button Ground Clearance | | 8 mm |
| 4 | Button Ground Clearance | 0.5 mm | 2 mm | Button ground clearance = Overlay Thickness |
| 5 | Ground Flood - Top Layer | | | Hatched ground 7 mil trace and 45 mil grid (15% filling) |
| 6 | Ground Flood - Bottom Layer | | | Hatched ground 7 mil trace and 70 mil grid (10% filling) |
| 7 | Trace Length from Sensor to PSoC - Buttons | | 200 mm | < 100 mm. |
| 8 | Trace Width | 0.17 mm | 0.20 mm | 0.17 mm (7 mil) |
| 9 | Trace Routing | | | Traces should be routed on the non sensor side. If any non CapSense trace crosses CapSense trace, ensure that intersection is orthogonal. |
| 10 | Via Position for the Sensors | | | Via should be placed near the edge of the button/slider to reduce trace length thereby increasing sensitivity. |
| 11 | Via Hole Size for Sensor Traces | | | 10 mil |
| 12 | No. of Via on Sensor Trace | 1 | 2 | 1 |
| 13 | CapSense Series Resistor Placement | | 10mm | Place CapSense series resistors close to PSoC for noise suppression. CapSense resistors have highest priority place them first. |
| 14 | Distance between any CapSense Trace to Ground Flood | 10 mil | 20 mil | 20 mil |
| 15 | Device Placement | | | Mount the device on the layer opposite to sensor. The CapSense trace length between the device and sensors should be minimum |
| 16 | Placement of Components in 2 Layer PCB | | | Top layer-sensor pads and bottom layer-PSoC, other components and traces. |
| 17 | Placement of Components in 4 Layer PCB | | | Top layer-sensor pads, second layer – CapSense traces, third layer-hatched ground, bottom layer- PSoC, other components and non CapSense traces |
| 18 | Overlay Thickness - Buttons | 0 mm | 2 mm | 1 mm |
| 19 | Overlay Material | | | Should to be non conductive material. Glass, ABS Plastic, Formica |
| 20 | Overlay Adhesives | | | Adhesive should be non conductive and dielectrically homogenous. 467MP and 468MP adhesives made by 3M are recommended. |
| 21 | LED Back Lighting | | | Cut a hole in the sensor pad and use rear mountable LEDs. Refer Example PCB Layout Design with Two CapSense Buttons and Two LEDs on page 26. |
| 22 | Board Thickness | | | Standard board thickness for CapSense FR4 based designs is 1.6 mm. |

Figure 7. Button Shapes

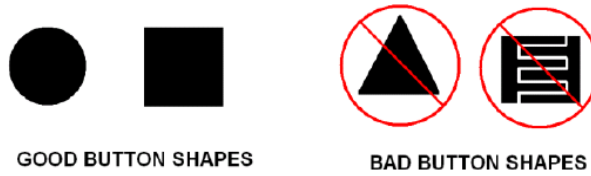
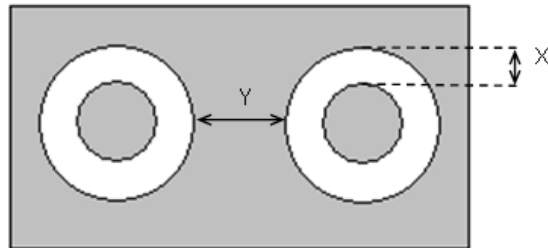
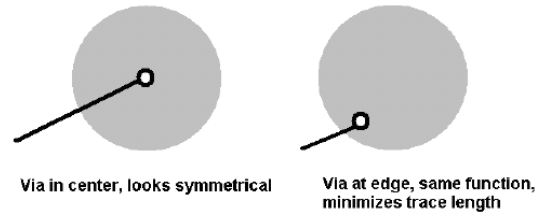

Figure 8. Button Layout Design



X: Button to ground clearance
Y: Button to button clearance

Figure 9. Recommended Via-hole Placement



8.1 Example PCB Layout Design with Two CapSense Buttons and Two LEDs

Figure 10. Top Layer

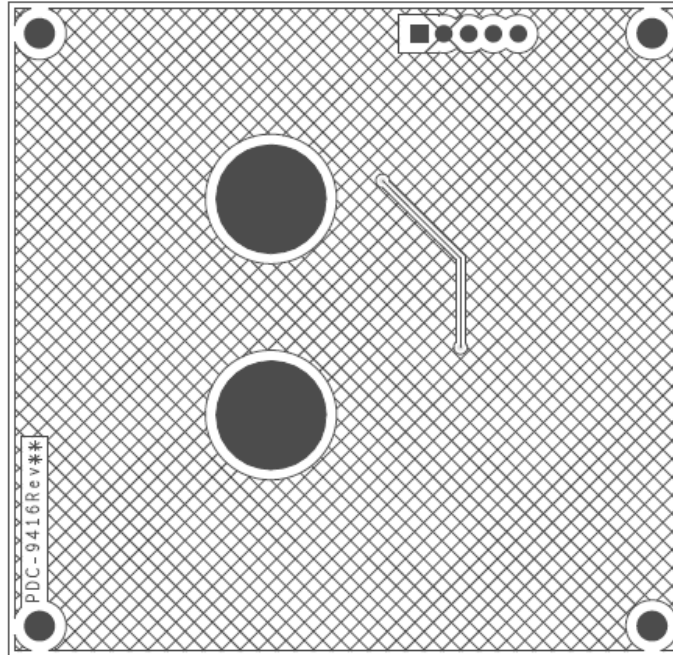
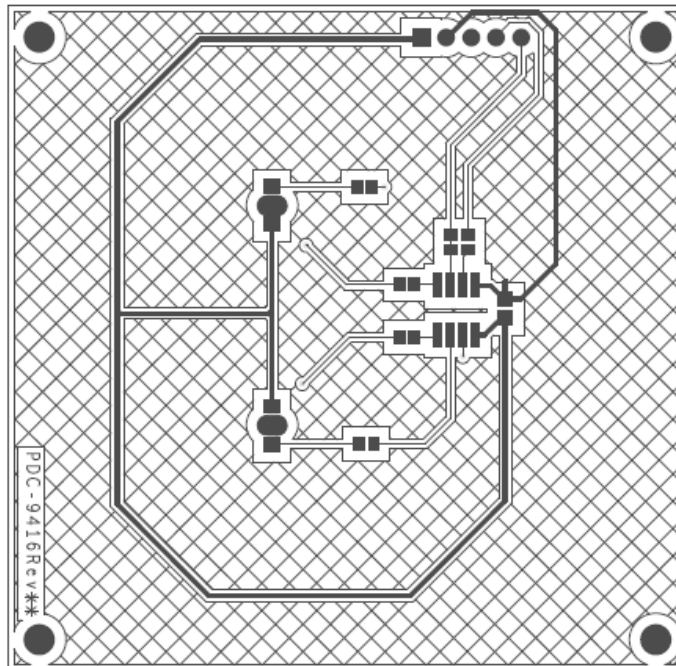

Figure 11. Bottom Layer



9. Operating Voltages

| | | | | |
|------|---------------------------------|-----------------------------------|--------------------|--------------------|
| 5.25 | | | | |
| 4.72 | | | | |
| 3.60 | | | | |
| 3.10 | | | | |
| 3.02 | | | | |
| 2.90 | | | | |
| 2.45 | | | | |
| 2.40 | | | | |
| 1.80 | | | | |
| 0 | | | | |
| | Valid Device Operating range | Valid CapSense Operating range | I2C 1x Ack mode | I2C 4x Ack mode |

For details on I2C 1x Ack time, refer [Register Map](#) on page 7 and [CapSense Express Commands](#) on page 8. I2C 4x Ack time is approximately four times the values mentioned in these tables.

10. CapSense Constraints

| Parameter | Min | Typ | Max | Units | Notes |
|--|-----|-----|------|-------|--|
| Parasitic Capacitance (C_p) of the CapSense Sensor | | | 30 | pF | |
| Overlay Thickness | 0 | 1 | 2 | mm | All layout best practices followed, properly tuned and noise free condition. |
| Supply Voltage Variation (V_{DD}) | | | ± 5% | | |

11. Electrical Specifications

11.1 Absolute Maximum Ratings

| Parameter | Description | Min | Typ | Max | Unit | Notes |
|------------------|---|-----------------------|-----|-----------------------|------|--|
| T _{STG} | Storage temperature | -55 | 25 | +100 | °C | Higher storage temperatures reduce data retention time. Recommended storage temperature is +25°C ± 25°C (0°C to 50°C). Extended duration storage temperatures above 65°C degrade reliability |
| T _A | Ambient temperature with power applied | -40 | - | +85 | °C | |
| V _{DD} | Supply voltage on V _{DD} relative to V _{SS} | -0.5 | - | +6.0 | V | |
| V _{IO} | DC input voltage | V _{SS} - 0.5 | - | V _{DD} + 0.5 | V | |
| V _{IOZ} | DC voltage applied to tri-state | V _{SS} - 0.5 | - | V _{DD} + 0.5 | V | |
| I _{MIO} | Maximum current into any GPIO pin | -25 | - | +50 | mA | |
| ESD | Electro static discharge voltage | 2000 | - | - | V | Human body model ESD |
| LU | Latch up current | - | - | 200 | mA | |

11.2 Operating Temperature

| Parameter | Description | Min | Typ | Max | Unit | Notes |
|----------------|----------------------|-----|-----|------|------|-------|
| T _A | Ambient temperature | -40 | - | +85 | °C | |
| T _J | Junction temperature | -40 | - | +100 | °C | |

11.3 DC Electrical Characteristics

11.3.1 DC Chip Level Specifications

| Parameter | Description | Min | Typ | Max | Unit | Notes |
|-----------------|----------------|------|-----|------|------|---|
| V _{DD} | Supply voltage | 2.40 | – | 5.25 | V | |
| I _{DD} | Supply current | – | 1.5 | 2.5 | mA | Conditions are V _{DD} = 3.10V, T _A = 25°C |

11.3.2 5V and 3.3V DC General Purpose I/O Specifications

This table lists guaranteed maximum and minimum specifications for the voltage and temperature ranges: 4.75V to 5.25V and -40°C ≤ T_A ≤ 85°C, 3.10V to 3.6V -40°C ≤ T_A ≤ 85°C. Typical parameters apply to 5V and 3.3V at 25°C and are for design guidance only.

| Parameter | Description | Min | Typ | Max | Unit | Notes |
|------------------|-----------------------------------|-----------------------|-----|------|------|---|
| V _{OH1} | High output voltage | V _{DD} – 0.2 | – | – | V | I _{OH} ≤ 10 μA/pin, V _{DD} ≥ 3.10V |
| V _{OH2} | High output voltage | V _{DD} – 0.9 | – | – | V | I _{OH} = 1 mA/pin, V _{DD} ≥ 3.10V |
| V _{OL} | Low output voltage | – | – | 0.75 | V | I _{OL} = 20 mA/pin, V _{DD} > 3.10V, maximum of 40 mA sink current |
| C _{OUT} | Capacitive load on pins as output | 0.5 | 1.7 | 5 | pF | Package and pin dependent. Temp = 25°C. |

11.3.3 2.7 DC General Purpose I/O Specifications

This table lists guaranteed maximum and minimum specifications for the voltage and temperature ranges: 2.4V to 2.90V and -40°C < T_A < 85°C, respectively. Typical parameters apply to 2.7V at 25°C and are for design guidance only.

| Parameter | Description | Min | Typ | Max | Unit | Notes |
|------------------|-----------------------------------|-----------------------|-----|------|------|--|
| V _{OH1} | High output voltage | V _{DD} – 0.2 | – | – | V | I _{OH} ≤ 10 μA/pin |
| V _{OH2} | High output voltage | V _{DD} – 0.5 | – | – | V | I _{OH} = 0.2 mA/pin |
| V _{OL} | Low output voltage | – | – | 0.75 | V | I _{OL} = 10 mA/pin, maximum of 20 mA sink current |
| C _{OUT} | Capacitive load on pins as output | 0.5 | 1.7 | 5 | pF | Package and pin dependent. Temp = 25°C. |

11.3.4 2.7V DC Spec for I²C Line with 1.8V External Pull-Up

This table lists guaranteed maximum and minimum specifications for the voltage and temperature ranges: 2.4V to 2.9V and 3.10V to 3.60V, and -40°C ≤ T_A ≤ 85°C, respectively. Typical parameters apply to 2.7V at 25°C. The I²C lines drive mode must be set to open drain and pulled up to 1.8V externally.

| Parameter | Description | Min | Typ | Max | Unit | Notes |
|------------------|--|-----|-----|------|------|--|
| V _{OLP} | Low output voltage | – | – | 0.4 | V | I _{OL} = 5 mA/pin, maximum of 10 mA device sink current 2.4 ≤ V _{DD} ≤ 2.9V and 3.1 ≤ V _{DD} ≤ 3.6V. |
| V _{IL} | Input low voltage | – | – | 0.75 | V | V _{DD} = 2.4 to 2.90V and 3.10V to 3.6V. |
| V _{IH} | Input high voltage | 1.4 | – | – | V | V _{DD} = 2.4 to 2.7V. |
| C _{I2C} | Capacitive load on I ² C pins | 0.5 | 1.7 | 5 | pF | Package and pin dependent. Temp = 25°C. |
| R _{PU} | Pull up resistor | 4 | 5.6 | 8 | kΩ | |

11.3.5 DC POR and LVD Specifications

| Parameter | Description | Min | Typ | Max | Unit | Notes |
|--------------------|---|-----|------|------|------|--|
| V _{PPOR0} | V _{DD} Value for PPOR Trip V _{DD} = 2.7V | – | 2.36 | 2.40 | V | V _{DD} must be greater than or equal to 2.5V during startup or reset from watchdog. |
| V _{PPOR1} | V _{DD} = 3.3V, 5V | – | 2.60 | 2.65 | V | |

11.3.6 DC Flash Write Specifications

This table lists guaranteed maximum and minimum specifications for the voltage and temperature ranges: 4.75V to 5.25V and -40°C<TA<85°C, 3.10V to 3.6V and -40°C<TA<85°C or 2.4V to 2.90V and -40°C<TA<85°C, respectively. Typical parameters apply to 5V, 3.3V, or 2.7V at 25°C. These are for design guidance only. Flash Endurance and Retention specifications are valid only within the range: 25°C±20°C during the Flash Write operation. It is at the user’s own risk to operate out of this temperature range. If Flash writing is done out of this temperature range, the endurance and data retention reduces.

| Symbol | Description | Min | Typ | Max | Units | Notes |
|-----------------------|--|--------|-----|-----|-------|--------------------|
| Vdd _{IWRITE} | Supply Voltage for Flash Write Operations ^[6] | 2.7 | – | – | V | |
| I _{DDP} | Supply Current for Flash Write Operations | – | 5 | 25 | mA | |
| Flash _{ENPB} | Flash Endurance | 50,000 | – | – | – | Erase/write cycles |
| Flash _{DR} | Flash Data Retention | 10 | – | – | Years | |

11.4 CapSense Electrical Characteristics

| Max (V) | Typ (V) | Min (V) | Conditions for Supply Voltage | Result |
|---------|---------|---------|-------------------------------|--|
| 3.6 | 3.3 | 3.1 | <2.9 | The device automatically reconfigures itself to work in 2.7V mode of operation. |
| | | | >2.9 or <3.10 | This range is not recommended for CapSense usage. |
| 2.90 | 2.7 | 2.45 | <2.45V | The scanning for CapSense parameters shuts down until the voltage returns to over 2.45V. |
| | | | >3.10 | The device automatically reconfigures itself to work in 3.3V mode of operation. |
| | | | <2.4V | The device goes into reset. |
| 5.25 | 5.0 | 4.75 | <4.73V | The scanning for CapSense parameters shuts down until the voltage returns to over 4.73V. |

Note

7. Commands involving Flash Writes (0x01, 0x02, 0x03) must be executed only within the same VCC voltage range detected at POR (power on, or command 0x06) and above 2.7V.

11.5 AC Electrical Specifications

11.5.1 5V and 3.3V AC General Purpose I/O Specifications

| Parameter | Description | Min | Max | Unit | Notes |
|-----------|--------------------------------------|-----|-----|------|---|
| TRise | Rise time, strong mode, Load = 50 pF | 15 | 80 | ns | V _{DD} = 3.10V to 3.6V and 4.75V to 5.25V, 10% - 90% |
| TFall | Fall time, strong mode, Load = 50 pF | 10 | 50 | ns | V _{DD} = 3.10V to 3.6V and 4.75V to 5.25V, 10% - 90% |

11.5.2 2.7V AC General Purpose I/O Specifications

| Parameter | Description | Min | Max | Unit | Notes |
|-----------|--------------------------------------|-----|-----|------|--|
| TRise | Rise time, strong mode, Load = 50 pF | 15 | 100 | ns | V _{DD} = 2.4V to 2.90V, 10% - 90% |
| TFall | Fall time, strong mode, Load = 50 pF | 10 | 70 | ns | V _{DD} = 2.4V to 2.90V, 10% - 90% |

11.5.3 AC I²C Specifications

| Parameter | Description | Standard Mode | | Fast Mode | | Units | Notes |
|--|---|---------------|-----|-----------|-----|-------|--|
| | | Min | Max | Min | Max | | |
| F _{SCL} ^{I²C} | SCL clock frequency | 0 | 100 | 0 | 400 | kbps | Fast mode not supported for V _{DD} < 3.0V |
| T _{HDSTA} ^{I²C} | Hold time (repeated) START condition. After this period, the first clock pulse is generated | 4.0 | – | 0.6 | – | µs | |
| T _{LOW} ^{I²C} | LOW period of the SCL clock | 4.7 | – | 1.3 | – | µs | |
| T _{HIGH} ^{I²C} | HIGH period of the SCL clock | 4.0 | – | 0.6 | – | µs | |
| T _{SUSTA} ^{I²C} | Setup time for a repeated START condition | 4.7 | – | 0.6 | – | µs | |
| T _{HDDAT} ^{I²C} | Data hold time | 0 | – | 0 | – | µs | |
| T _{SUDAT} ^{I²C} | Data setup time | 250 | – | 100 | – | ns | |
| T _{SUSTO} ^{I²C} | Setup time for STOP condition | 4.0 | – | 0.6 | – | µs | |
| T _{BUF} ^{I²C} | BUS free time between a STOP and START condition | 4.7 | – | 1.3 | – | µs | |
| T _{SP} ^{I²C} | Pulse width of spikes suppressed by the input filter | – | – | 0 | 50 | ns | |

Figure 12. Definition of Timing for Fast/Standard Mode on the I²C Bus

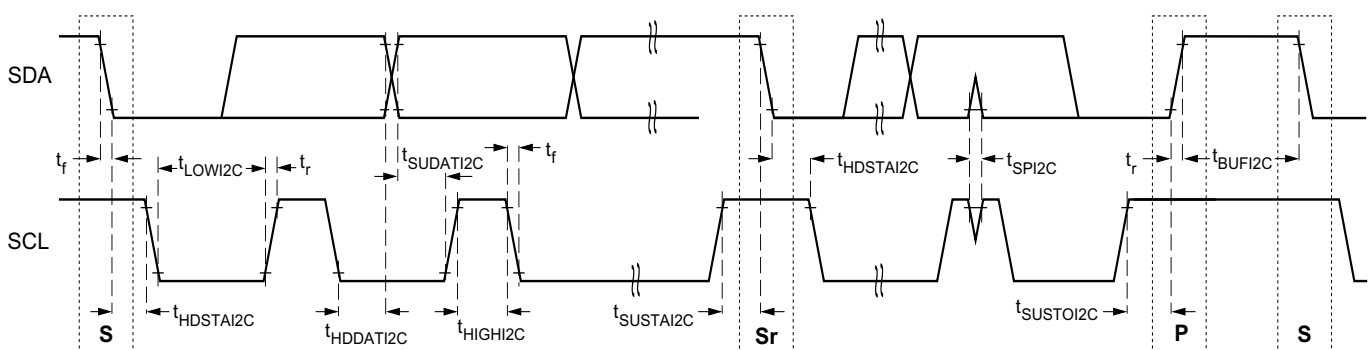

12. Examples of Frequently Used I²C Commands

| SI. No. | Requirement | I ² C Commands ^[7] | Comment |
|---------|---|--|--|
| 1 | Enter into setup mode | W 00 A0 08 | |
| 2 | Enter into normal mode | W 00 A0 07 | |
| 3 | Load factory defaults to RAM registers | W 00 A0 02 | |
| 4 | Do a software reset | W 00 A0 08 W 00 A0 06 | ; Enter into setup mode ; Do software reset |
| 5 | Save current configuration to flash | W 00 A0 01 | |
| 6 | Load factory defaults to RAM registers and save as user configuration | W 00 A0 08 W 00 A0 02 W 00 A0 01 W 00 A0 06 | ; Enter into setup mode ; Load factory defaults to SRAM ; Save the configuration to Flash. Wait for time specified in Table 6 . ; Do software reset |
| 7 | Disable combinational logic output to DIG0 | W 00 1C 00 | |
| 8 | Disable combinational logic output to DIG1 | W 00 21 00 | |
| 9 | Clearing (logic 0) the both DIG0 and DIG1 outputs | W 00 04 00 | Combinational logic output on DIG0 and DIG1 should be disabled before doing this operation (SL# 7 and 8) |
| 10 | Setting (logic 1) the DIG0 and clearing (Logic 0) the DIG1 outputs | W 00 04 01 | |
| 11 | Clearing (logic 0) the DIG0 and Setting (Logic 1) the DIG1 outputs | W 00 04 02 | |
| 12 | Setting (logic 1) the both DIG0 and DIG1 outputs | W 00 04 03 | |
| 13 | Change CapSense clock to IMO/2 | W 00 A0 08 W 00 51 20 W 00 A0 07 | ; Enter into setup mode ; CapSense clock is set as IMO/2 ; Enter into normal mode |
| 14 | Change value of IDAC0 to 'x'h | W 00 70 x | 'x' represents new value of IDAC register |
| 15 | Change value of IDAC1 to 'y'h | W 00 71 y | 'y' represents new value of IDAC register |
| 16 | Change value of IDAC0 and IDAC1 to 'x'h and 'y'h | W 00 70 x y | 'x' and 'y' represents new value of IDAC register |
| 17 | Change the value FT0 to 'x'h | W 00 66 x | 'x' represents new value of FT register |
| 18 | Change the value FT1 to 'y'h | W 00 67 y | 'y' represents new value of FT register |
| 19 | Change the value FT0 and FT1 to 'x'h and 'y'h | W 00 66 x y | 'x' and 'y' represents new value of FT registers |
| 20 | Change noise threshold to 'x'h | W 00 4E x | |
| 21 | Read CapSense button CS0 scan results | W 00 81 81 W 00 82 R 00 RD RD RD RD RD RD | ; Select CapSense button for reading scan result ; Set the read point to 82h ; Consecutive 6 reads gets baseline, difference count and raw count (all two byte each) |
| 22 | Read CapSense button status register | W 00 88 R 00 RD | ; Set the read pointer to 88 ; Reading a byte gets status CapSense inputs |

Note

8. The 'W' indicates the write transfer and the next byte of data represents the 7-bit I2C address. The I2C address is assumed to be '0' in the above examples. Similarly 'R' indicates the read transfer followed by 7-bit address and data byte read operations.

13. Ordering Information

| Ordering Code | Package Diagram | Package Type | Operating Temperature | CapSense Blocks | CapSense Inputs | Digital Outputs | XRES Pin |
|-----------------|-----------------|------------------------|-----------------------|-----------------|-----------------|-----------------|----------|
| CY8C20111-SX1I | 51-85066 | 8 SOIC | Industrial | Yes | 1 | 1 | No |
| CY8C20111-SX1IT | 51-85066 | 8 SOIC (Tape and Reel) | Industrial | Yes | 1 | 1 | No |
| CY8C20121-SX1I | 51-85066 | 8 SOIC | Industrial | Yes | 2 | 2 | No |
| CY8C20121-SX1IT | 51-85066 | 8 SOIC (Tape and Reel) | Industrial | Yes | 2 | 2 | No |

Note For Die sales information, contact a local Cypress sales office or Field Applications Engineer (FAE).

13.1 Ordering Code Information

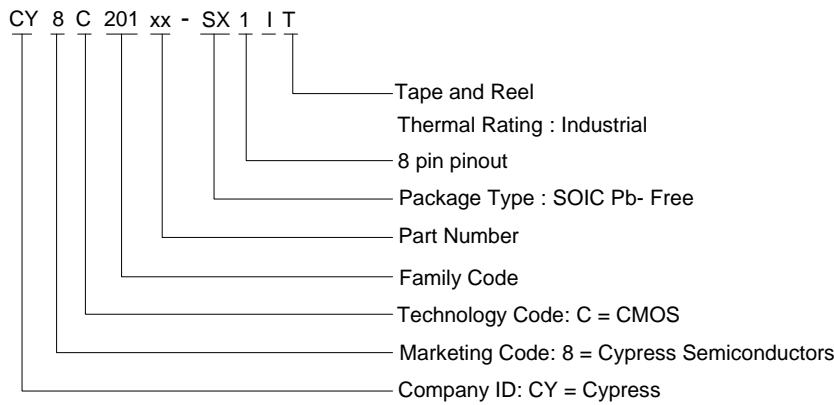

14. Package Diagram

Figure 13. 8-Pin (150-Mil) SOIC (51-85066)

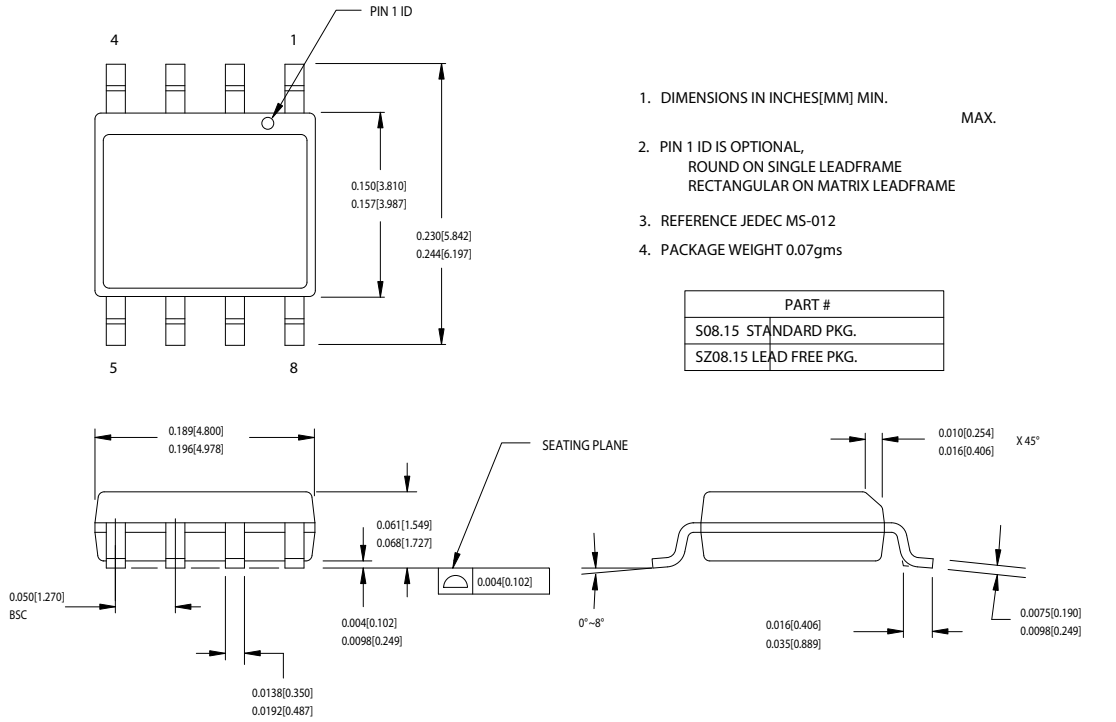

51-85066-°C

15. Document History Page

| Document Title: CY8C20111, CY8C20121 CapSense Express™ - One Button and Two Button Capacitive Controllers Document Number: 001-53516 | | | | |
|---|---------|-----------------|-----------------|-----------------------|
| Rev. | ECN. | Orig. of Change | Submission Date | Description of Change |
| ** | 2709248 | SLAN/PYRS | See ECN | New data sheet |

16. Sales, Solutions, and Legal Information

16.1 Worldwide Sales and Design Support

Cypress maintains a worldwide network of offices, solution centers, manufacturer’s representatives, and distributors. To find the office closest to you, visit us at cypress.com/sales.

16.2 Products

| | |
|------------------|--|
| PSoC | psoc.cypress.com |
| Clocks & Buffers | clocks.cypress.com |
| Wireless | wireless.cypress.com |
| Memories | memory.cypress.com |
| Image Sensors | image.cypress.com |

© Cypress Semiconductor Corporation, 2009. The information contained herein is subject to change without notice. Cypress Semiconductor Corporation assumes no responsibility for the use of any circuitry other than circuitry embodied in a Cypress product. Nor does it convey or imply any license under patent or other rights. Cypress products are not warranted nor intended to be used for medical, life support, life saving, critical control or safety applications, unless pursuant to an express written agreement with Cypress. Furthermore, Cypress does not authorize its products for use as critical components in life-support systems where a malfunction or failure may reasonably be expected to result in significant injury to the user. The inclusion of Cypress products in life-support systems application implies that the manufacturer assumes all risk of such use and in doing so indemnifies Cypress against all charges.

Any Source Code (software and/or firmware) is owned by Cypress Semiconductor Corporation (Cypress) and is protected by and subject to worldwide patent protection (United States and foreign), United States copyright laws and international treaty provisions. Cypress hereby grants to licensee a personal, non-exclusive, non-transferable license to copy, use, modify, create derivative works of, and compile the Cypress Source Code and derivative works for the sole purpose of creating custom software and or firmware in support of licensee product to be used only in conjunction with a Cypress integrated circuit as specified in the applicable agreement. Any reproduction, modification, translation, compilation, or representation of this Source Code except as specified above is prohibited without the express written permission of Cypress.

Disclaimer: CYPRESS MAKES NO WARRANTY OF ANY KIND, EXPRESS OR IMPLIED, WITH REGARD TO THIS MATERIAL, INCLUDING, BUT NOT LIMITED TO, THE IMPLIED WARRANTIES OF MERCHANTABILITY AND FITNESS FOR A PARTICULAR PURPOSE. Cypress reserves the right to make changes without further notice to the materials described herein. Cypress does not assume any liability arising out of the application or use of any product or circuit described herein. Cypress does not authorize its products for use as critical components in life-support systems where a malfunction or failure may reasonably be expected to result in significant injury to the user. The inclusion of Cypress’ product in a life-support systems application implies that the manufacturer assumes all risk of such use and in doing so indemnifies Cypress against all charges.

Use may be limited by and subject to the applicable Cypress software license agreement.