

## EPF8268S & EPF8268S-LF

- Complies with or exceeds IEEE 802.3 & ANSI X3.263 Standards
- Add “-LF” after part number for Lead-Free
- Storage Temperature : -40°C to +125°C
- Operating Temperature : 0°C to +70°C

### Electrical Parameters @ 25° C

OCL ( $\mu$ H Min.)	Insertion Loss (dB Max.)			Return Loss (dB Min.)			Common Mode Rejection (dB Min.)			
	@ 1 MHz	@ 100 MHz	@ 125 MHz	@ 1 MHz	@ 40 MHz	@ 100 MHz	@ 30 MHz	@ 50 MHz	@ 100 MHz	@ 150 MHz
100 KHz, 0.1 Vrms 8 mA DC Bias	Xmit/Rcv	Xmit/Rcv	Xmit/Rcv	Xmit/Rcv	Xmit/Rcv	Xmit/Rcv	Xmit/Rcv	Xmit/Rcv	Xmit/Rcv	Xmit/Rcv
350	-1/-1	-1.2/-1.2	-2/-2	-16/-16	-16/-16	-8/-8	-40/-40	-40/-40	-30/-30	-20/-20

• Isolation : 1650 Vrms (Pri. to Sec.) • Crosstalk : -35 dB Min. @ 1-100 MHz •

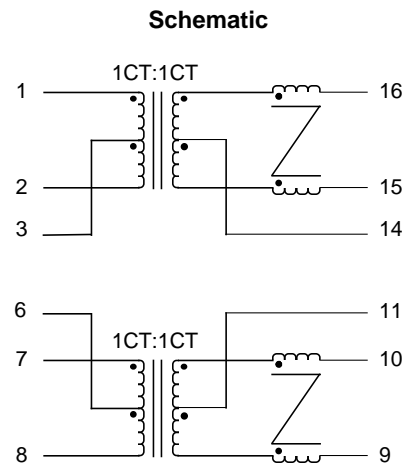
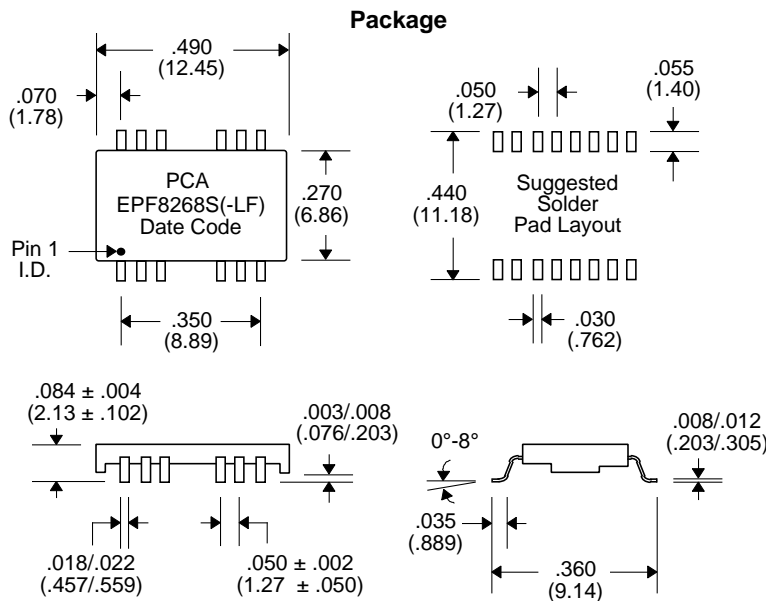

Notes :	EPF8268S	EPF8268S-LF
1. Lead Finish	SnPb	Hot Tin Dip (Sn)
2. Peak Temperature Rating	225°C	245°C
3. Moisture Sensitive Levels	MSL = 3 (168 Hours, 30°C/60%RH)	MSL = 4 (72 Hours, 30°C/60%RH)
4. Weight	TBD grams	TBD grams
5. Packaging Information (Tube)	TBD pieces/tube	TBD pieces/tube
(Tape & Reel)	1500 pieces/13" reel	1500 pieces/13" reel

Unless Otherwise Specified Dimensions are in Inches /mm  $\pm$  .010 / .25