

10/100 LAN Interface Module for NIC/HUB Applications

EPF8106S

- Robust construction allows for toughest soldering processes *
- Guaranteed to operate with 8 mA DC bias at 70°C on cable side •
- Complies with or exceeds IEEE 802.3, 10 BT/100 BX Standards •

Electrical Parameters @ 25° C

OCL @ 70°C	Insertion Loss (dB Max.)						Return Loss (dB Min.)						Common Mode Rejection (dB Min.)						Crosstalk (dB Min.) [Between Channels]	
	1-80 MHz		80-100 MHz		100-150 MHz		1-30 MHz		30-60 MHz		60-100 MHz		1-30 MHz		30-100 MHz		100-500 MHz		1-10 MHz	10-100 MHz
Cable Side	Xmit	Rcv	Xmit	Rcv	Xmit	Rcv	Xmit	Rcv	Xmit	Rcv	Xmit	Rcv	Xmit	Rcv	Xmit	Rcv	Xmit	Rcv		
350μH	-1	-1	-2	-2	-3.5	-3	-18	-18	-10	-10	-8	-10	-35	-40	-30	-30	-8	-10	-40	-40

• Isolation : 1500 Vrms • Impedance : 400 Ω Xmit / 100 Ω Rcv • Rise Time : 3.0 nS Max. •

Schematic

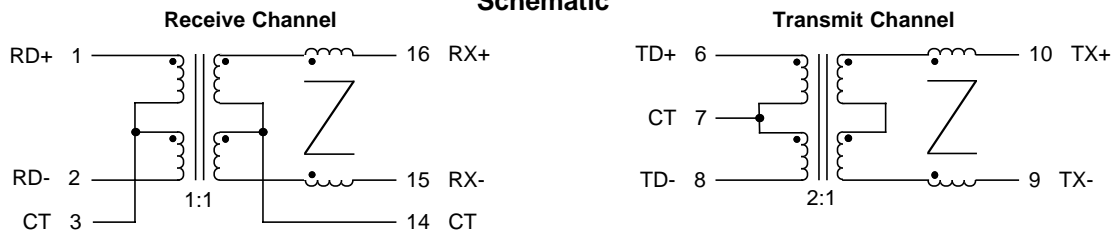

Package

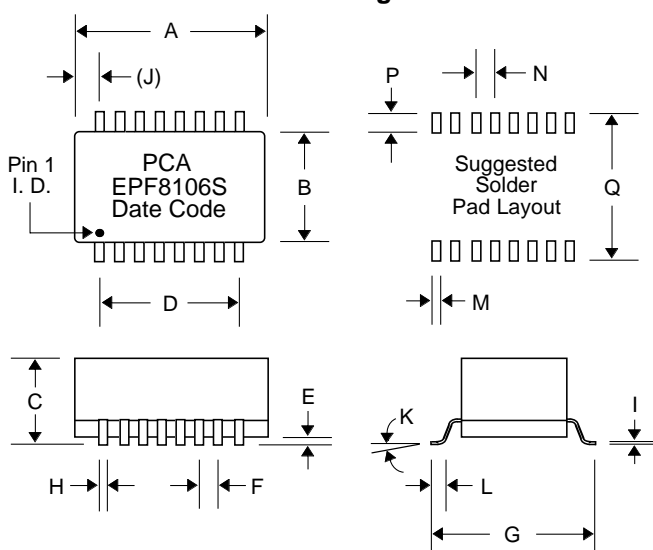

Dimensions

Dim.	(Inches)			(millimeters)		
	Min.	Max.	Nom.	Min.	Max.	Nom.
A	.480	.500		12.19	12.70	
B	.260	.280		6.60	7.11	
C	.180	.200		4.57	5.08	
D	.350	Typ.		8.89	Typ.	
E	.010	.015		.254	.381	
F	.050	Typ.		1.27	Typ.	
G	.370	.390		9.40	9.91	
H	.016	.022		.406	.559	
I	.010	Typ.		.254	Typ.	
J	.070	Typ.		1.78	Typ.	
K	0°	8°		0°	8°	
L	.025	.045		.635	1.14	
M			.030			.762
N			.050			1.27
P			.055			1.40
Q			.410			10.41