

KEY FEATURES

ADSP-219x, 16-Bit, Fixed Point DSP Core with up to 160 MIPS Sustained Performance
 40K Words of On-Chip RAM, Configured as 32K Words On-Chip 24-Bit Program RAM and 8K Words On-Chip 16-Bit Data RAM
 External Memory Interface
 Dedicated Memory DMA Controller for Data/Instruction Transfer between Internal/External Memory
 Programmable PLL and Flexible Clock Generation Circuitry Enables Full Speed Operation from Low Speed Input Clocks
 IEEE JTAG Standard 1149.1 Test Access Port Supports On-Chip Emulation and System Debugging
 8-Channel, 14-Bit Analog-to-Digital Converter System, with up to 20 MSPS Sampling Rate (at 160 MHz Core Clock Rate)

Three Phase 16-Bit Center Based PWM Generation Unit with 12.5 ns Resolution at 160 MHz Core Clock (CCLK) Rate
 Dedicated 32-Bit Encoder Interface Unit with Companion Encoder Event Timer
 Dual 16-Bit Auxiliary PWM Outputs
 16 General-Purpose Flag I/O Pins
 Three Programmable 32-Bit Interval Timers
 SPI Communications Port with Master or Slave Operation
 Synchronous Serial Communications Port (SPORT) Capable of Software UART Emulation
 Integrated Watchdog Timer
 Dedicated Peripheral Interrupt Controller with Software Priority Control
 Multiple Boot Modes
 Precision 1.0 V Voltage Reference

FUNCTIONAL BLOCK DIAGRAM

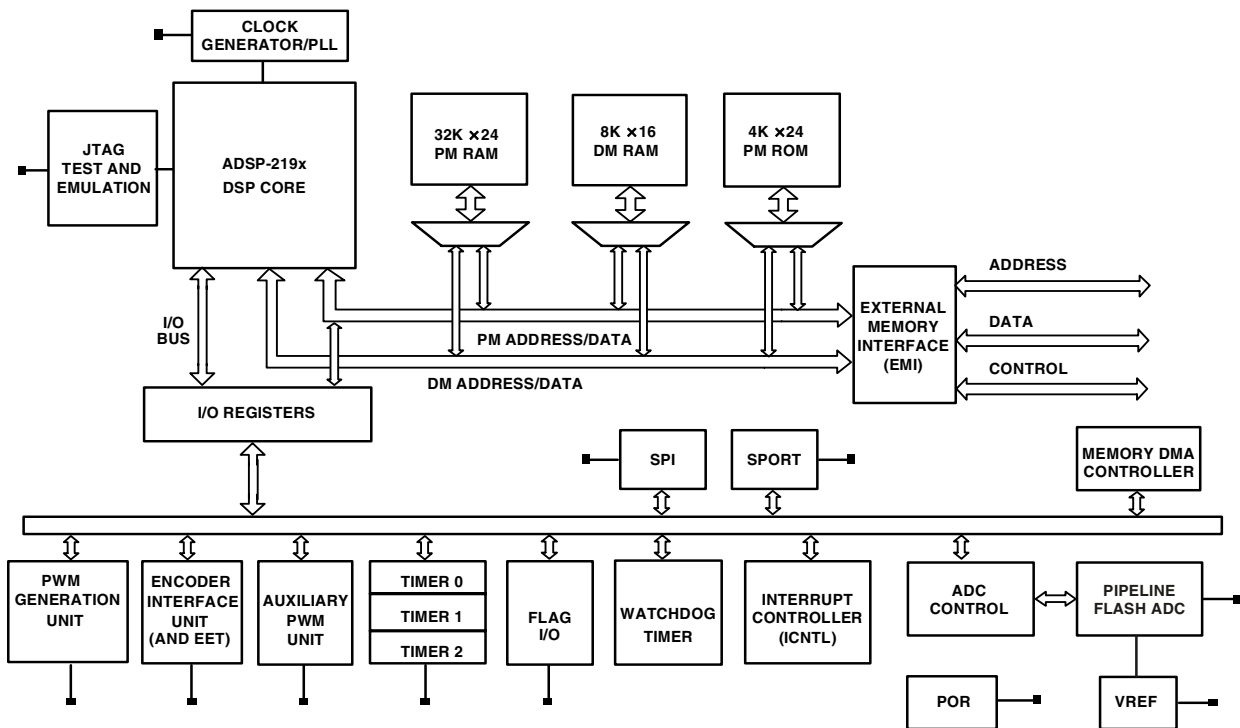

REV. 0

Information furnished by Analog Devices is believed to be accurate and reliable. However, no responsibility is assumed by Analog Devices for its use, nor for any infringements of patents or other rights of third parties that may result from its use. No license is granted by implication or otherwise under any patent or patent rights of Analog Devices. Trademarks and registered trademarks are the property of their respective companies.

One Technology Way, P.O. Box 9106, Norwood, MA 02062-9106, U.S.A.
 Tel: 781/329-4700 www.analog.com
 Fax: 781/326-8703 © 2003 Analog Devices, Inc. All rights reserved.

ADSP-21991

KEY FEATURES (continued)

Integrated Power-On-Reset (POR) Generator
Flexible Power Management with Selectable Power-Down and Idle Modes
2.5 V Internal Operation with 3.3 V I/O
Operating Temperature Range of -40°C to $+85^{\circ}\text{C}$
196-Ball Mini-BGA Package
176-Lead LQFP Package

TARGET APPLICATIONS

Industrial Motor Drives
Uninterruptible Power Supplies
Optical Networking Control
Data Acquisition Systems
Test and Measurement Systems
Portable Instrumentation

TABLE OF CONTENTS

GENERAL DESCRIPTION	2
DSP Core Architecture	3
Memory Architecture	4
Internal (On-Chip) Memory	5
External (Off-Chip) Memory	5
External Memory Space	5
I/O Memory Space	5
Boot Memory Space	6
Bus Request and Bus Grant	6
DMA Controller	6
DSP Peripherals Architecture	6
Serial Peripheral Interface (SPI) Port	7
DSP Serial Port (SPORT)	7
Analog-to-Digital Conversion System	8
Voltage Reference	8
PWM Generation Unit	8
Auxiliary PWM Generation Unit	9
Encoder Interface Unit	9
Flag I/O (FIO) Peripheral Unit	10
Watchdog Timer	10
General-Purpose Timers	10
Interrupts	10
Peripheral Interrupt Controller	11
Low Power Operation	11
Idle Mode	11
Power-Down Core Mode	11
Power-Down Core/Peripherals Mode	12
Power-Down All Mode	12
Clock Signals	12
Reset and Power-On Reset (POR)	12
Power Supplies	12
Bootling Modes	13
Instruction Set Description	13
Development Tools	13
Designing an Emulator-Compatible DSP Board	14
Additional Information	14
PIN FUNCTION DESCRIPTIONS	14
SPECIFICATIONS	17
ABSOLUTE MAXIMUM RATINGS	22
ESD SENSITIVITY	22

TIMING SPECIFICATIONS	22
Clock In and Clock Out Cycle Timing	23
Programmable Flags Cycle Timing	24
Timer PWM_OUT Cycle Timing	25
External Port Write Cycle Timing	26
External Port Read Cycle Timing	27
External Port Bus Request/Grant Cycle Timing	28
Serial Port Timing	29
Serial Peripheral Interface Port—Master Timing	32
Serial Peripheral Interface Port—Slave Timing	33
JTAG Test And Emulation Port Timing	34
Power Dissipation	35
Test Conditions	35
Output Disable Time	35
Output Enable Time	35
Example System Hold Time Calculation	35
Pin Configurations	36
OUTLINE DIMENSIONS	41
ORDERING GUIDE	42

GENERAL DESCRIPTION

The ADSP-21991 is a mixed signal DSP controller based on the ADSP-219x DSP Core, suitable for a variety of high performance industrial motor control and signal processing applications that require the combination of a high performance DSP and the mixed signal integration of embedded control peripherals such as analog-to-digital conversion.

The ADSP-21991 integrates the fixed point ADSP-219x family base architecture with a serial port, an SPI compatible port, a DMA controller, three programmable timers, general-purpose Programmable Flag pins, extensive interrupt capabilities, on-chip program and data memory spaces, and a complete set of embedded control peripherals that permits fast motor control and signal processing in a highly integrated environment.

The ADSP-21991 architecture is code compatible with previous ADSP-217x based ADMCxxx products. Although the architectures are compatible, the ADSP-21991, with ADSP-219x architecture, has a number of enhancements over earlier architectures. The enhancements to computational units, data address generators, and program sequencer make the ADSP-21991 more flexible and easier to program than the previous ADSP-21xx embedded DSPs.

Indirect addressing options provide addressing flexibility—premodify with no update, pre- and post-modify by an immediate 8-bit, twos complement value and base address registers for easier implementation of circular buffering.

The ADSP-21991 integrates 40K words of on-chip memory configured as 32K words (24-bit) of program RAM, and 8K words (16-bit) of data RAM.

Fabricated in a high speed, low power, CMOS process, the ADSP-21991 operates with a 6.25 ns instruction cycle time for a 160 MHz CCLK and with a 6.67 ns instruction cycle time for a 150 MHz CCLK. All instructions, except two multiword instructions, execute in a single DSP cycle.

The flexible architecture and comprehensive instruction set of the ADSP-21991 support multiple operations in parallel. For example, in one processor cycle, the ADSP-21991 can:

- Generate an address for the next instruction fetch
- Fetch the next instruction
- Perform one or two data moves
- Update one or two data address pointers
- Perform a computational operation

These operations take place while the processor continues to:

- Receive and transmit data through the serial port
- Receive or transmit data over the SPI port
- Access external memory through the external memory interface
- Decrement the timers
- Operate the embedded control peripherals (ADC, PWM, EIU, etc.)

DSP Core Architecture

- 6.25 ns instruction cycle time (internal), for up to 160 MIPS sustained performance (6.67 ns instruction cycle time for 150 MIPS sustained performance)
- ADSP-218x family code compatible with the same easy to use algebraic syntax
- Single cycle instruction execution
- Up to 1M words of addressable memory space with twenty four bits of addressing width
- Dual purpose program memory for both instruction and data storage
- Fully transparent instruction cache allows dual operand fetches in every instruction cycle
- Unified memory space permits flexible address generation, using two independent DAG units
- Independent ALU, multiplier/accumulator, and barrel shifter computational units with dual 40-bit accumulators
- Single cycle context switch between two sets of computational and DAG registers
- Parallel execution of computation and memory instructions
- Pipelined architecture supports efficient code execution at speeds up to 160 MIPS
- Register file computations with all nonconditional, non-parallel computational instructions
- Powerful program sequencer provides zero overhead looping and conditional instruction execution
- Architectural enhancements for compiled C code efficiency
- Architecture enhancements beyond ADSP-218x family are supported with instruction set extensions for added registers, ports, and peripherals.

The clock generator module of the ADSP-21991 includes clock control logic that allows the user to select and change the main clock frequency. The module generates two output clocks: the DSP core clock, CCLK; and the peripheral clock, HCLK. CCLK can sustain clock values of up to 160 MHz, while HCLK can be equal to CCLK or CCLK/2 for values up to a maximum 80 MHz peripheral clock at the 160 MHz CCLK rate.

The ADSP-21991 instruction set provides flexible data moves and multifunction (one or two data moves with a computation) instructions. Every single word instruction can be executed in a single processor cycle. The ADSP-21991 assembly language uses an algebraic syntax for ease of coding and readability. A comprehensive set of development tools supports program development.

The block diagram [Figure 1](#) shows the architecture of the embedded ADSP-219x core. It contains three independent computational units: the ALU, the multiplier/accumulator (MAC), and the shifter. The computational units process 16-bit data from the register file and have provisions to support multiprecision computations. The ALU performs a standard set of arithmetic and logic operations; division primitives are also supported. The MAC performs single cycle multiply, multiply/add, and multiply/subtract operations. The MAC has two 40-bit accumulators, which help with overflow. The shifter performs logical and arithmetic shifts, normalization, denormalization, and derive exponent operations. The shifter can be used to efficiently implement numeric format control, including multiword and block floating point representations.

Register usage rules influence placement of input and results within the computational units. For most operations, the data registers of the computational units act as a data register file, permitting any input or result register to provide input to any unit for a computation. For feedback operations, the computational units let the output (result) of any unit be input to any unit on the next cycle. For conditional or multifunction instructions, there are restrictions on which data registers may provide inputs or receive results from each computational unit. For more information, see the *ADSP-219x DSP Instruction Set Reference*.

A powerful program sequencer controls the flow of instruction execution. The sequencer supports conditional jumps, subroutine calls, and low interrupt overhead. With internal loop counters and loop stacks, the ADSP-21991 executes looped code with zero overhead; no explicit jump instructions are required to maintain loops.

Two data address generators (DAGs) provide addresses for simultaneous dual operand fetches (from data memory and program memory). Each DAG maintains and updates four 16-bit address pointers. Whenever the pointer is used to access data (indirect addressing), it is pre- or post-modified by the value of one of four possible modify registers. A length value and base address may be associated with each pointer to implement automatic modulo addressing for circular buffers. Page registers in the DAGs allow circular addressing within 64K word boundaries of each of the 256 memory pages, but these buffers may not cross page boundaries. Secondary registers duplicate all the primary registers in the DAGs; switching between primary and secondary registers provides a fast context switch.

ADSP-21991

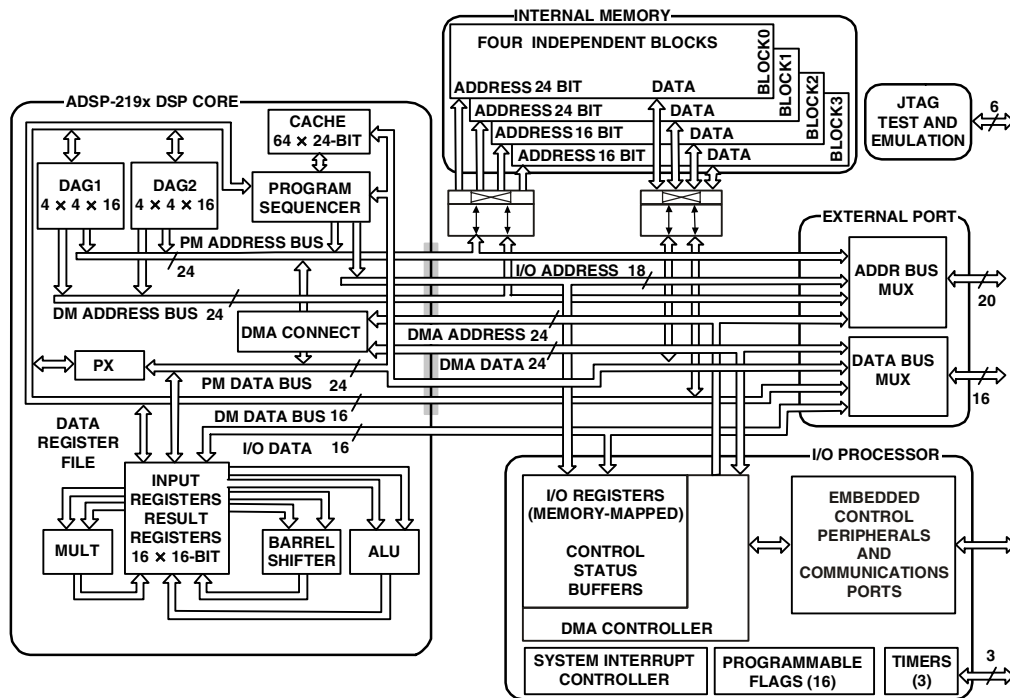

Figure 1. Block Diagram

Efficient data transfer in the core is achieved with the use of internal buses:

- Program Memory Address (PMA) Bus
- Program Memory Data (PMD) Bus
- Data Memory Address (DMA) Bus
- Data Memory Data (DMD) Bus
- Direct Memory Access Address Bus
- Direct Memory Access Data Bus

The two address buses (PMA and DMA) share a single external address bus, allowing memory to be expanded off-chip, and the two data buses (PMD and DMD) share a single external data bus. Boot memory space and I/O memory space also share the external buses.

Program memory can store both instructions and data, permitting the ADSP-21991 to fetch two operands in a single cycle, one from program memory and one from data memory. The DSP dual memory buses also let the embedded ADSP-219x core fetch an operand from data memory and the next instruction from program memory in a single cycle.

Memory Architecture

The ADSP-21991 provides 40K words of on-chip SRAM memory. This memory is divided into three blocks: two $16K \times 24$ -bit blocks (blocks 0 and 1) and one $8K \times 16$ -bit block (block 2). In addition, the ADSP-21991 provides a $4K \times 24$ -bit block of program memory boot ROM (that is reserved by ADI for boot load routines). The memory map of the ADSP-21991 is illustrated in Figure 2.

As shown in Figure 2, the three internal memory RAM blocks reside in memory page 0. The entire DSP memory map consists of 256 pages (pages 0 to 255), and each page is 64K words long. External memory space consists of four memory banks (banks 3–0) and supports a wide variety of memory devices. Each bank is selectable using unique memory select lines ($\overline{MS3-0}$) and has configurable page boundaries, wait states, and wait state modes. The 4K words of on-chip boot ROM populates the top of page 255, while the remaining 254 pages are addressable off-chip. I/O memory pages differ from external memory in that they are 1K word long, and the external I/O pages have their own select pin (IOMS). Pages 31–0 of I/O memory space reside on-chip and

contain the configuration registers for the peripherals. Both the ADSP-219x core and DMA capable peripherals can access the entire memory map of the DSP.

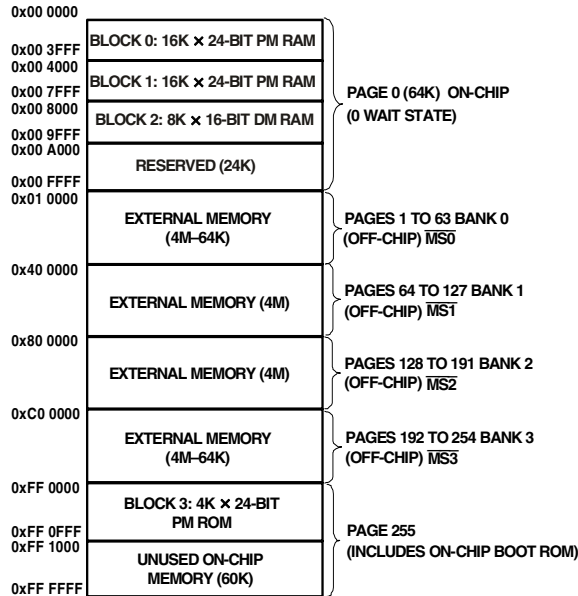

Figure 2. Core Memory Map at Reset

NOTE: The physical external memory addresses are limited by 20 address lines, and are determined by the external data width and packing of the external memory space. The Strobe signals ($\overline{MS3-0}$) can be programmed to allow the user to change starting page addresses at run time.

Internal (On-Chip) Memory

The unified program and data memory space of the ADSP-21991 consists of 16M locations that are accessible through two 24-bit address buses, the PMA, and DMA buses. The DSP uses slightly different mechanisms to generate a 24-bit address for each bus. The DSP has three functions that support access to the full memory map.

- The DAGs generate 24-bit addresses for data fetches from the entire DSP memory address range. Because DAG index (address) registers are 16 bits wide and hold the lower 16 bits of the address, each of the DAGs has its own 8-bit page register (DMPG_x) to hold the most significant eight address bits. Before a DAG generates an address, the program must set the DAG DMPG_x register to the appropriate memory page. The DMPG₁ register is also used as a page register when accessing external memory. The program must set DMPG₁ accordingly, when accessing data variables in external memory. A “C” program macro is provided for setting this register.
- The program sequencer generates the addresses for instruction fetches. For relative addressing instructions, the program sequencer bases addresses for relative jumps,

calls, and loops on the 24-bit program counter (PC). In direct addressing instructions (two word instructions), the instruction provides an immediate 24-bit address value. The PC allows linear addressing of the full 24-bit address range.

- For indirect jumps and calls that use a 16-bit DAG address register for part of the branch address, the Program Sequencer relies on an 8-bit Indirect Jump page (IJPg) register to supply the most significant eight address bits. Before a cross page jump or call, the program must set the program sequencer IJPg register to the appropriate memory page.

The ADSP-21991 has 4K word of on-chip ROM that holds boot routines. The DSP starts executing instructions from the on-chip boot ROM, which starts the boot process. See [Booting Modes on Page 13](#). The on-chip boot ROM is located on Page 255 in the DSP memory space map, starting at address 0xFF0000.

External (Off-Chip) Memory

Each of the off-chip memory spaces of the ADSP-21991 has a separate control register, so applications can configure unique access parameters for each space. The access parameters include read and write wait counts, wait state completion mode, I/O clock divide ratio, write hold time extension, strobe polarity, and data bus width. The core clock and peripheral clock ratios influence the external memory access strobe widths. See [Clock Signals on Page 12](#). The off-chip memory spaces are:

- External memory space ($\overline{MS3-0}$ pins)
- I/O memory space (\overline{IOMS} pin)
- Boot memory space (\overline{BMS} pin)

All of these off-chip memory spaces are accessible through the External Port, which can be configured for 8-bit or 16-bit data widths.

External Memory Space

External memory space consists of four memory banks. These banks can contain a configurable number of 64K word pages. At reset, the page boundaries for external memory have Bank0 containing pages 1 to 63, Bank1 containing pages 64 to 127, Bank2 containing pages 128 to 191, and Bank3 containing pages 192 to 254. The $\overline{MS3-0}$ memory bank pins select Banks 3-0, respectively. Both the ADSP-219x core and DMA capable peripherals can access the DSP external memory space.

All accesses to external memory are managed by the External Memory Interface Unit (EMI).

I/O Memory Space

The ADSP-21991 supports an additional external memory called I/O memory space. The IO space consists of 256 pages, each containing 1024 addresses. This space is designed to support simple connections to peripherals (such as data converters and external registers) or to bus interface ASIC data registers. The first 32K addresses (IO pages 0 to 31) are reserved for on-chip peripherals. The upper 224K addresses (IO pages 32 to

ADSP-21991

255) are available for external peripheral devices. External I/O pages have their own select pin (IOMS). The DSP instruction set provides instructions for accessing I/O space.

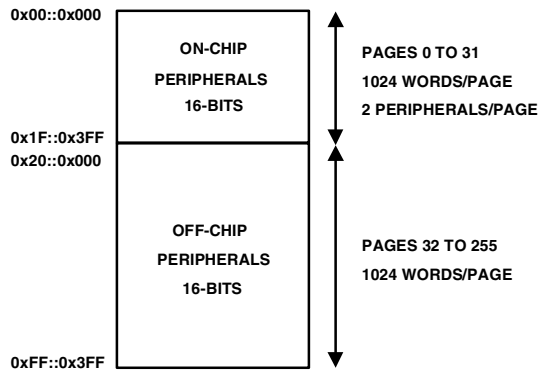

Figure 3. I/O Memory Map

Boot Memory Space

Boot memory space consists of one off-chip bank with 254 pages. The $\overline{\text{BMS}}$ memory bank pin selects boot memory space. Both the ADSP-219x core and DMA capable peripherals can access the off-chip boot memory space of the DSP. After reset, the DSP always starts executing instructions from the on-chip boot ROM.

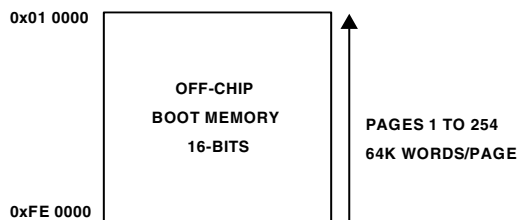

Figure 4. Boot Memory Map

Bus Request and Bus Grant

The ADSP-21991 can relinquish control of the data and address buses to an external device. When the external device requires access to the bus, it asserts the bus request ($\overline{\text{BR}}$) signal. The ($\overline{\text{BR}}$) signal is arbitrated with core and peripheral requests. External Bus requests have the lowest priority. If no other internal request is pending, the external bus request will be granted. Due to synchronizer and arbitration delays, bus grants will be provided with a minimum of three peripheral clock delays. The ADSP-21991 will respond to the bus grant by:

- Three-stating the data and address buses and the $\overline{\text{MS3-0}}$, $\overline{\text{BMS}}$, $\overline{\text{IOMS}}$, $\overline{\text{RD}}$, and $\overline{\text{WR}}$ output drivers.
- Asserting the bus grant ($\overline{\text{BG}}$) signal.

The ADSP-21991 will halt program execution if the bus is granted to an external device and an instruction fetch or data read/write request is made to external general-purpose or peripheral memory spaces. If an instruction requires two external memory read accesses, the bus will not be granted between the

two accesses. If an instruction requires an external memory read and an external memory write access, the bus may be granted between the two accesses. The external memory interface can be configured so that the core will have exclusive use of the interface. DMA and Bus Requests will be granted. When the external device releases $\overline{\text{BR}}$, the DSP releases $\overline{\text{BG}}$ and continues program execution from the point at which it stopped.

The bus request feature operates at all times, even while the DSP is booting and $\overline{\text{RESET}}$ is active.

The ADSP-21991 asserts the $\overline{\text{BGH}}$ pin when it is ready to start another external port access, but is held off because the bus was previously granted. This mechanism can be extended to define more complex arbitration protocols for implementing more elaborate multimaster systems.

DMA Controller

The ADSP-21991 has a DMA controller that supports automated data transfers with minimal overhead for the DSP core. Cycle stealing DMA transfers can occur between the ADSP-21991 internal memory and any of its DMA capable peripherals. Additionally, DMA transfers can be accomplished between any of the DMA capable peripherals and external devices connected to the external memory interface. DMA capable peripherals include the SPORT and SPI ports, and ADC Control module. Each individual DMA capable peripheral has a dedicated DMA channel. To describe each DMA sequence, the DMA controller uses a set of parameters—called a DMA descriptor. When successive DMA sequences are needed, these DMA descriptors can be linked or chained together, so the completion of one DMA sequence auto initiates and starts the next sequence. DMA sequences do not contend for bus access with the DSP core, instead DMAs “steal” cycles to access memory.

All DMA transfers use the DMA bus shown in Figure 1 on Page 4. Because all of the peripherals use the same bus, arbitration for DMA bus access is needed. The arbitration for DMA bus access appears in Table 1.

Table 1. I/O Bus Arbitration Priority

DMA Bus Master	Arbitration Priority
SPORT Receive DMA	0—Highest
SPORT Transmit DMA	1
ADC Control DMA	2
SPI Receive/Transmit DMA	3
Memory DMA	4—Lowest

DSP Peripherals Architecture

The ADSP-21991 contains a number of special purpose, embedded control peripherals, which can be seen in the Functional Block Diagram on Page 1. The ADSP-21991 contains a high performance, 8-channel, 14-bit ADC system with dual channel simultaneous sampling ability across four pairs of inputs. An internal precision voltage reference is also available as part of the ADC system. In addition, a 3-phase, 16-bit, center based PWM generation unit can be used to produce high accuracy PWM signals with minimal processor overhead. The ADSP-21991 also contains a flexible incremental encoder interface unit

for position sensor feedback; two adjustable frequency auxiliary PWM outputs, 16 lines of digital I/O; a 16-bit watchdog timer; three general-purpose timers, and an interrupt controller that manages all peripheral interrupts. Finally, the ADSP-21991 contains an integrated power-on-reset (POR) circuit that can be used to generate the required reset signal for device power-on.

The ADSP-21991 has an external memory interface that is shared by the DSP core, the DMA controller, and DMA capable peripherals, which include the ADC, SPORT, and SPI communication ports. The external port consists of a 16-bit data bus, a 20-bit address bus, and control signals. The data bus is configurable to provide an 8- or 16-bit interface to external memory. Support for word packing lets the DSP access 16- or 24-bit words from external memory regardless of the external data bus width.

The memory DMA controller lets the ADSP-21991 move data and instructions from between memory spaces: internal-to-external, internal-to-internal, and external-to-external. On-chip peripherals can also use this controller for DMA transfers.

The embedded ADSP-219x core can respond to up to seventeen interrupts at any given time: three internal (stack, emulator kernel, and power-down), two external (emulator and reset), and twelve user defined (peripherals) interrupts. Programmers assign each of the 32 peripheral interrupt requests to one of the 12 user defined interrupts. These assignments determine the priority of each peripheral for interrupt service.

The following sections provide a functional overview of the ADSP-21991 peripherals.

Serial Peripheral Interface (SPI) Port

The Serial Peripheral Interface (SPI) Port provides functionality for a generic configurable serial port interface based on the SPI standard, which enables the DSP to communicate with multiple SPI compatible devices. Key features of the SPI port are:

- Interface to host microcontroller or serial EEPROM
- Master or slave operation (3-wire interface MISO, MOSI, SCK)
- Data rates to $HCLK \div 4$ (16-bit baud rate selector)
- 8- or 16-bit transfer
- Programmable clock phase and polarity
- Broadcast Mode – 1 master, multiple slaves
- DMA capability and dedicated interrupts
- PF0 can be used as slave select input line
- PF7–1 can be used as external slave select output

SPI is a 3 wire interface consisting of 2 data pins (MOSI and MISO), one clock pin (SCK), and a single Slave Select input (SPISS) that is multiplexed with the PF0 Flag IO line and seven Slave Select outputs (SPISEL1 to SPISEL7) that are multiplexed with the PF1 to PF7 Flag IO lines. The SPISS input is used to select the ADSP-21991 as a slave to an external master. The SPISEL1 to SPISEL7 outputs can be used by the ADSP-21991 (acting as a master) to select/enable up to seven external slaves in an multi device SPI configuration. In a multimaster or a multi-device configuration, all MOSI pins are tied together, all MISO pins are tied together, and all SCK pins are tied together.

During transfers, the SPI port simultaneously transmits and receives by serially shifting data in and out on the serial data line. The serial clock line synchronizes the shifting and sampling of data on the serial data line.

In master mode, the DSP core performs the following sequence to set up and initiate SPI transfers:

1. Enables and configures the SPI port operation (data size, and transfer format).
2. Selects the target SPI slave with the SPISELx output pin (reconfigured Programmable Flag pin).
3. Defines one or more DMA descriptors in Page 0 of I/O memory space (optional in DMA mode only).
4. Enables the SPI DMA engine and specifies transfer direction (optional in DMA mode only).
5. In non DMA mode only, reads or writes the SPI port receive or transmit data buffer.

The SCK line generates the programmed clock pulses for simultaneously shifting data out on MOSI and shifting data in on MISO. In DMA mode only, transfers continue until the SPI DMA word count transitions from 1 to 0.

In slave mode, the DSP core performs the following sequence to set up the SPI port to receive data from a master transmitter:

1. Enables and configures the SPI slave port to match the operation parameters set up on the master (data size and transfer format) SPI transmitter.
2. Defines and generates a receive DMA descriptor in Page 0 of memory space to interrupt at the end of the data transfer (optional in DMA mode only).
3. Enables the SPI DMA engine for a receive access (optional in DMA mode only).
4. Starts receiving the data on the appropriate SCK edges after receiving an SPI chip select on the SPISS input pin (reconfigured Programmable Flag pin) from a master

In DMA mode only, reception continues until the SPI DMA word count transitions from 1 to 0. The DSP core could continue, by queuing up the next DMA descriptor.

A slave mode transmit operation is similar, except the DSP core specifies the data buffer in memory space from which to transmit data, generates and relinquishes control of the transmit DMA descriptor, and begins filling the SPI port data buffer. If the SPI controller is not ready on time to transmit, it can transmit a “zero” word.

DSP Serial Port (SPORT)

The ADSP-21991 incorporates a complete synchronous serial port (SPORT) for serial and multiprocessor communications. The SPORT supports the following features:

- Bidirectional: the SPORT has independent transmit and receive sections.
- Double buffered: the SPORT section (both receive and transmit) has a data register for transferring data words to and from other parts of the processor and a register for shifting data in or out. The double buffering provides additional time to service the SPORT.

ADSP-21991

- Clocking: the SPORT can use an external serial clock or generate its own in a wide range of frequencies down to 0 Hz.
- Word length: each SPORT section supports serial data word lengths from three to sixteen bits that can be transferred either MSB first or LSB first.
- Framing: each SPORT section (receive and transmit) can operate with or without frame synchronization signals for each data-word; with internally generated or externally generated frame signals; with active high or active low frame signals; with either of two pulsewidths and frame signal timing.
- Companding in hardware: each SPORT section can perform A law and μ law companding according to CCITT recommendation G.711.
- Direct Memory Access with single cycle overhead: using the built-in DMA master, the SPORT can automatically receive and/or transmit multiple memory buffers of data with an overhead of only one DSP cycle per data-word. The on-chip DSP via a linked list of memory space resident DMA descriptor blocks can configure transfers between the SPORT and memory space. This chained list can be dynamically allocated and updated.
- Interrupts: each SPORT section (receive and transmit) generates an interrupt upon completing a data-word transfer, or after transferring an entire buffer or buffers if DMA is used.
- Multichannel capability: The SPORT can receive and transmit data selectively from channels of a serial bit stream that is time division multiplexed into up to 128 channels. This is especially useful for T1 interfaces or as a network communication scheme for multiple processors. The SPORTs also support T1 and E1 carrier systems.
- Each SPORT channel (Tx and Rx) supports a DMA buffer of up to eight, 16-bit transfers.
- The SPORT operates at a frequency of up to one-half the clock frequency of the HCLK
- The SPORT is capable of UART software emulation.

Analog-to-Digital Conversion System

The ADSP-21991 contains a fast, high accuracy, multiple input analog-to-digital conversion system with simultaneous sampling capabilities. This A/D conversion system permits the fast, accurate conversion of analog signals needed in high performance embedded systems. Key features of the ADC system are:

- 14-bit Pipeline (6-Stage Pipeline) Flash Analog-to-Digital Converter.
- 8 dedicated analog inputs.
- Dual channel simultaneous sampling capability.
- Programmable ADC clock rate to maximum of $HCLK \div 4$.
- First channel ADC data valid approximately 375 ns after CONVST (at 20 MSPS).

- All 8 inputs converted in approximately 725 ns (at 20 MSPS).
- 2.0 V peak-to-peak input voltage range.
- Multiple convert start sources.
- Internal or external Voltage Reference.
- Out of range detection.
- DMA capable transfers from ADC to memory.

The ADC system is based on a pipeline flash converter core, and contains dual input sample-and-hold amplifiers so that simultaneous sampling of two input signals is supported. The ADC system provides an analog input voltage range of 2.0 V_{p-p} and provides 14-bit performance with a clock rate of up to $HCLK \div 4$. The ADC system can be programmed to operate at a clock rate that is programmable from $HCLK/4$ to $HCLK/30$, to a maximum of 20 MHz (at 160 MHz CCLK rate).

The ADC input structure supports 8 independent analog inputs; four of which are multiplexed into one sample-and-hold amplifier (A_SHA) and 4 of which are multiplexed into the other sample-and-hold amplifier (B_SHA).

At the 20 MHz sampling rate, the first data value is valid approximately 375 ns after the Convert Start command. All 8 channels are converted in approximately 725 ns.

The core of the ADSP-21991 provides 14-bit data such that the stored data values in the ADC data registers are 14 bits wide.

Voltage Reference

The ADSP-21991 contains an onboard band gap reference that can be used to provide a precise 1.0 V output for use by the A/D system and externally on the VREF pin for biasing and level shifting functions. Additionally, the ADSP-21991 may be configured to operate with an external reference applied to the VREF pin, if required.

PWM Generation Unit

Key features of the 3-phase PWM generation unit are:

- 16-bit, center based PWM generation unit
- Programmable PWM pulsewidth, with resolutions to 12.5 ns (at 80 MHz HCLK Rate)
- Single/double update modes
- Programmable dead time and switching frequency
- Twos complement implementation permits smooth transition into full ON and full OFF states
- Possibility to synchronize the PWM generation to an external synchronization
- Special provisions for BDCM Operation (crossover and output enable functions)
- Wide variety of special switched reluctance (SR) operating modes
- Output polarity and clock gating control
- Dedicated asynchronous PWM shutdown signal
- Multiple shutdown sources, independently for each unit

The ADSP-21991 integrates a flexible and programmable, 3-phase PWM waveform generator that can be programmed to generate the required switching patterns to drive a 3-phase voltage source inverter for ac induction (ACIM) or permanent magnet synchronous (PMSM) motor control. In addition, the PWM block contains special functions that considerably simplify the generation of the required PWM switching patterns for control of the electronically commutated motor (ECM) or brushless dc motor (BDCM). Tying a dedicated pin, $\overline{\text{PWMSR}}$, to GND, enables a special mode, for switched reluctance motors (SRM).

The six PWM output signals consist of three high side drive pins (AH, BH, and CH) and three low side drive signals pins (AL, BL, and CL). The polarity of the generated PWM signals may be set via hardware by the PWMPOL input pin, so that either active HI or active LO PWM patterns can be produced.

The switching frequency of the generated PWM patterns is programmable using the 16-bit PWMTM register. The PWM generator is capable of operating in two distinct modes, single update mode or double update mode. In single update mode the duty cycle values are programmable only once per PWM period, so that the resultant PWM patterns are symmetrical about the midpoint of the PWM period. In the double update mode, a second updating of the PWM registers is implemented at the midpoint of the PWM period. In this mode, it is possible to produce asymmetrical PWM patterns that produce lower harmonic distortion in 3-phase PWM inverters.

Auxiliary PWM Generation Unit

Key features of the auxiliary PWM generation unit are:

- 16-bit, programmable frequency, programmable duty cycle PWM outputs
- Independent or offset operating modes
- Double buffered control of duty cycle and period registers
- Separate auxiliary PWM synchronization signal and associated interrupt (can be used to trigger ADC Convert Start).
- Separate auxiliary PWM shutdown signal ($\overline{\text{AUXTRIP}}$).

The ADSP-21991 integrates a 2-channel, 16-bit, auxiliary PWM output unit that can be programmed with variable frequency, variable duty cycle values and may operate in two different modes, independent mode or offset mode. In independent mode, the two auxiliary PWM generators are completely independent and separate switching frequencies and duty cycles may be programmed for each auxiliary PWM output. In offset mode the switching frequency of the two signals on the AUX0 and AUX1 pins is identical. Bit 4 of the AUXCTRL register places the auxiliary PWM channel pair in independent or offset mode.

The Auxiliary PWM generation unit provides two chip output pins, AUX0 and AUX1 (on which the switching signals appear), and one chip input pin, $\overline{\text{AUXTRIP}}$, which can be used to shut down the switching signals—for example in a fault condition.

Encoder Interface Unit

The ADSP-21991 incorporates a powerful encoder interface block to incremental shaft encoders that are often used for position feedback in high performance motion control systems.

- Quadrature rates to 53 MHz (at 80 MHz HCLK rate).
- Programmable filtering of all encoder input signals
- 32-bit encoder counter
- Variety of hardware and software reset modes
- Two registration inputs to latch EIU count value with corresponding registration interrupt
- Status of A/B signals latched with reading of EIU count value.
- Alternative frequency and direction mode
- Single north marker mode
- Count error monitor function with dedicated error interrupt
- Dedicated 16-bit loop timer with dedicated interrupt
- Companion encoder event (1/T) timer unit.

The encoder interface unit (EIU) includes a 32-bit quadrature up/down counter, programmable input noise filtering of the encoder input signals and the zero markers, and has four dedicated chip pins. The quadrature encoder signals are applied at the EIA and EIB pins. Alternatively, a frequency and direction set of inputs may be applied to the EIA and EIB pins. In addition, two north marker/strobe inputs are provided on pins EIZ and EIS. These inputs may be used to latch the contents of the encoder quadrature counter into dedicated registers, EIZLATCH and EISLATCH, on the occurrence of external events at the EIZ and EIS pins. These events may be programmed to be either rising edge only (latch event) or rising edge if the encoder is moving in the forward direction and falling edge if the encoder is moving in the reverse direction (software latched north marker functionality).

The encoder interface unit incorporates programmable noise filtering on the four encoder inputs to prevent spurious noise pulses from adversely affecting the operation of the quadrature counter. The encoder interface unit operates at a clock frequency equal to the HCLK rate. The encoder interface unit operates correctly with encoder signals at frequencies of up to 13.25 MHz at the 80 MHz HCLK rate, corresponding to a maximum quadrature frequency of 53 MHz (assuming an ideal quadrature relationship between the input EIA and EIB signals).

The EIU may be programmed to use the north marker on EIZ to reset the quadrature encoder in hardware, if required.

Alternatively, the north marker can be ignored, and the encoder quadrature counter is reset according to the contents of a maximum count register, EIUMAXCNT. There is also a “single north marker” mode available in which the encoder quadrature counter is reset only on the first north marker pulse.

ADSP-21991

The encoder interface unit can also be made to implement some error checking functions. If an encoder count error is detected (due to a disconnected encoder line, for example), a status bit in the EIUSTAT register is set, and an EIU count error interrupt is generated.

The encoder interface unit of the ADSP-21991 contains a 16-bit loop timer that consists of a timer register, period register and scale register so that it can be programmed to time out and reload at appropriate intervals. When this loop timer times out, an EIU loop timer timeout interrupt is generated. This interrupt could be used to control the timing of speed and position control loops in high performance drives.

The encoder interface unit also includes a high performance encoder event timer (EET) block that permits the accurate timing of successive events of the encoder inputs. The EET can be programmed to time the duration between up to 255 encoder pulses and can be used to enhance velocity estimation, particularly at low speeds of rotation.

Flag I/O (FIO) Peripheral Unit

The FIO module is a generic parallel I/O interface that supports sixteen bidirectional multifunction flags or general-purpose digital I/O signals (PF15–0).

All sixteen FLAG bits can be individually configured as an input or output based on the content of the direction (DIR) register, and can also be used as an interrupt source for one of two FIO interrupts. When configured as input, the input signal can be programmed to set the FLAG on either a level (level sensitive input/interrupt) or an edge (edge sensitive input/interrupt).

The FIO module can also be used to generate an asynchronous unregistered wake-up signal FIO_WAKEUP for DSP core wake up after power-down.

The FIO Lines, PF7–1 can also be configured as external slave select outputs for the SPI communications port, while PF0 can be configured to act as a slave select input.

The FIO Lines can be configured to act as a PWM shutdown source for the 3-phase PWM generation unit of the ADSP-21991.

Watchdog Timer

The ADSP-21991 integrates a watchdog timer that can be used as a protection mechanism against unintentional software events. It can be used to cause a complete DSP and peripheral reset in such an event. The watchdog timer consists of a 16-bit timer that is clocked at the external clock rate (CLKIN or crystal input frequency).

In order to prevent an unwanted timeout or reset, it is necessary to periodically write to the watchdog timer register. During abnormal system operation, the watchdog count will eventually decrement to 0 and a watchdog timeout will occur. In the system, the watchdog timeout will cause a full reset of the DSP core and peripherals.

General-Purpose Timers

The ADSP-21991 contains a general-purpose timer unit that contains three identical 32-bit timers. The three programmable interval timers (Timer0, Timer1, and Timer2) generate periodic interrupts. Each timer can be independently set to operate in one of three modes:

- Pulse Waveform Generation (PWM_OUT) mode
- Pulsewidth Count/Capture (WDTH_CAP) mode
- External Event Watchdog (EXT_CLK) mode

Each Timer has one bidirectional chip pin, TMR2-0. For each timer, the associated pin is configured as an output pin in PWM_OUT Mode and as an input pin in WDTH_CAP and EXT_CLK Modes.

Interrupts

The interrupt controller lets the DSP respond to 17 interrupts with minimum overhead. The DSP core implements an interrupt priority scheme as shown in Table 2. Applications can use the unassigned slots for software and peripheral interrupts. The Peripheral Interrupt Controller is used to assign the various peripheral interrupts to the 12 user assignable interrupts of the DSP core.

Table 2. Interrupt Priorities/Addresses

Interrupt	IMASK/ IRPTL	Vector Address
Emulator (NMI) —Highest Priority	NA	NA
Reset (NMI)	0	0x00 0000
Power-Down (NMI)	1	0x00 0020
Loop and PC Stack Emulation Kernel	2	0x00 0040
User Assigned Interrupt (USR0)	3	0x00 0060
User Assigned Interrupt (USR1)	4	0x00 0080
User Assigned Interrupt (USR2)	5	0x00 00A0
User Assigned Interrupt (USR3)	6	0x00 00C0
User Assigned Interrupt (USR4)	7	0x00 00E0
User Assigned Interrupt (USR5)	8	0x00 0100
User Assigned Interrupt (USR6)	9	0x00 0120
User Assigned Interrupt (USR7)	10	0x00 0140
User Assigned Interrupt (USR8)	11	0x00 0160
User Assigned Interrupt (USR9)	12	0x00 0180

Table 2. Interrupt Priorities/Addresses

Interrupt	IMASK/ IRPTL	Vector Address
User Assigned Interrupt (USR9)	13	0x00 01A0
User Assigned Interrupt (USR10)	14	0x00 01C0
User Assigned Interrupt (USR11)	15	0x00 01E0
—Lowest Priority		

There is no assigned priority for the peripheral interrupts after reset. To assign the peripheral interrupts a different priority, applications write the new priority to their corresponding control bits (determined by their ID) in the Interrupt Priority Control register.

Interrupt routines can either be nested with higher priority interrupts taking precedence or processed sequentially. Interrupts can be masked or unmasked with the IMASK register. Individual interrupt requests are logically ANDed with the bits in IMASK; the highest priority unmasked interrupt is then selected. The emulation, power-down, and reset interrupts are nonmaskable with the IMASK register, but software can use the DIS INT instruction to mask the power-down interrupt.

The Interrupt Control (ICNTL) register controls interrupt nesting and enables or disables interrupts globally.

The IRPTL register is used to force and clear interrupts. On-chip stacks preserve the processor status and are automatically maintained during interrupt handling. To support interrupt, loop, and subroutine nesting, the PC stack is 33 levels deep, the loop stack is 8 levels deep, and the status stack is 16 levels deep. To prevent stack overflow, the PC stack can generate a stack level interrupt if the PC stack falls below 3 locations full or rises above 28 locations full.

The following instructions globally enable or disable interrupt servicing, regardless of the state of IMASK.

```
ENA INT;
DIS INT;
```

At reset, interrupt servicing is disabled.

For quick servicing of interrupts, a secondary set of DAG and computational registers exist. Switching between the primary and secondary registers lets programs quickly service interrupts, while preserving the state of the DSP.

Peripheral Interrupt Controller

The Peripheral Interrupt Controller is a dedicated peripheral unit of the ADSP-21991 (accessed via IO mapped registers). The peripheral interrupt controller manages the connection of up to 32 peripheral interrupt requests to the DSP core.

For each peripheral interrupt source, there is a unique 4-bit code that allows the user to assign the particular peripheral interrupt to any one of the 12 user assignable interrupts of the embedded ADSP-219x core. Therefore, the peripheral interrupt controller

of the ADSP-21991 contains eight, 16-bit Interrupt Priority Registers (Interrupt Priority Register 0 (IPR0) to Interrupt Priority Register 7 (IPR7)).

Each Interrupt Priority Register contains a four 4-bit codes; one specifically assigned to each peripheral interrupt. The user may write a value between 0x0 and 0xB to each 4-bit location in order to effectively connect the particular interrupt source to the corresponding user assignable interrupt of the ADSP-219x core.

Writing a value of 0x0 connects the peripheral interrupt to the USR0 user assignable interrupt of the ADSP-219x core while writing a value of 0xB connects the peripheral interrupt to the USR11 user assignable interrupt. The core interrupt USR0 is the highest priority user interrupt, while USR11 is the lowest priority. Writing a value between 0xC and 0xF effectively disables the peripheral interrupt by not connecting it to any ADSP-219x core interrupt input. The user may assign more than one peripheral interrupt to any given ADSP-219x core interrupt. In that case, the onus is on the user software in the interrupt vector table to determine the exact interrupt source through reading status bits.

This scheme permits the user to assign the number of specific interrupts that are unique to their application to the interrupt scheme of the ADSP-219x core. The user can then use the existing interrupt priority control scheme to dynamically control the priorities of the 12 core interrupts.

Low Power Operation

The ADSP-21991 has four low power options that significantly reduce the power dissipation when the device operates under standby conditions. To enter any of these modes, the DSP executes an IDLE instruction. The ADSP-21991 uses the configuration of the PD, STCK, and STALL bits in the PLLCTL register to select between the low power modes as the DSP executes the IDLE instruction. Depending on the mode, an IDLE shuts off clocks to different parts of the DSP in the different modes. The low power modes are:

- Idle
- Power-Down Core
- Power-Down Core/Peripherals
- Power-Down All

Idle Mode

When the ADSP-21991 is in Idle mode, the DSP core stops executing instructions, retains the contents of the instruction pipeline, and waits for an interrupt. The core clock and peripheral clock continue running.

To enter Idle mode, the DSP can execute the IDLE instruction anywhere in code. To exit Idle mode, the DSP responds to an interrupt and (after two cycles of latency) resumes executing instructions.

Power-Down Core Mode

When the ADSP-21991 is in Power-Down Core mode, the DSP core clock is off, but the DSP retains the contents of the pipeline and keeps the PLL running. The peripheral bus keeps running, letting the peripherals receive data.

ADSP-21991

To exit Power-Down Core mode, the DSP responds to an interrupt and (after two cycles of latency) resumes executing instructions.

Power-Down Core/Peripherals Mode

When the ADSP-21991 is in Power-Down Core/Peripherals mode, the DSP core clock and peripheral bus clock are off, but the DSP keeps the PLL running. The DSP does not retain the contents of the instruction pipeline. The peripheral bus is stopped, so the peripherals cannot receive data.

To exit Power-Down Core/Peripherals mode, the DSP responds to an interrupt and (after five to six cycles of latency) resumes executing instructions.

Power-Down All Mode

When the ADSP-21991 is in Power-Down All mode, the DSP core clock, the peripheral clock, and the PLL are all stopped. The DSP does not retain the contents of the instruction pipeline. The peripheral bus is stopped, so the peripherals cannot receive data.

To exit Power-Down Core/Peripherals mode, the DSP responds to an interrupt and (after 500 cycles to re-stabilize the PLL) resumes executing instructions.

Clock Signals

The ADSP-21991 can be clocked by a crystal oscillator or a buffered, shaped clock derived from an external clock oscillator. If a crystal oscillator is used, the crystal should be connected across the CLKIN and XTAL pins, with two capacitors connected as shown in Figure 5. Capacitor values are dependent on crystal type and should be specified by the crystal manufacturer. A parallel resonant, fundamental frequency, microprocessor grade crystal should be used for this configuration.

If a buffered, shaped clock is used, this external clock connects to the DSP CLKIN pin. CLKIN input cannot be halted, changed, or operated below the specified frequency during normal operation. This clock signal should be a TTL compatible signal. When an external clock is used, the XTAL input must be left unconnected.

The DSP provides a user programmable $1\times$ to $32\times$ multiplication of the input clock, including some fractional values, to support 128 external to internal (DSP core) clock ratios. The BYPASS pin, and MSEL6–0 and DF bits, in the PLL configuration register, decide the PLL multiplication factor at reset. At run time, the multiplication factor can be controlled in software. To support input clocks greater than 100 MHz, the PLL uses an additional bit (DF). If the input clock is greater than 100 MHz, DF must be set. If the input clock is less than 100 MHz, DF must be cleared. For clock multiplier settings, see the *ADSP-2199x Mixed Signal DSP Controller Hardware Reference*.

The peripheral clock is supplied to the CLKOUT pin.

All on-chip peripherals for the ADSP-21991 operate at the rate set by the peripheral clock. The peripheral clock (HCLK) is either equal to the core clock rate or one half the DSP core clock rate (CCLK). This selection is controlled by the IOSEL bit in the PLLCTL register. The maximum core clock is 160 MHz for the ADSP-21991BST and 150 MHz for the ADSP-21991BBC.

The maximum peripheral clock is 80 MHz for the ADSP-21991BST and 75 MHz for the ADSP-21991BBC—the combination of the input clock and core/peripheral clock ratios may not exceed these limits.

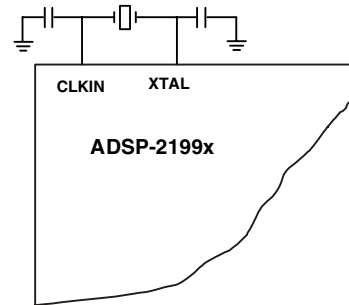

Figure 5. External Crystal Connections

Reset and Power-On Reset (POR)

The $\overline{\text{RESET}}$ pin initiates a complete hardware reset of the ADSP-21991 when pulled low. The $\overline{\text{RESET}}$ signal must be asserted when the device is powered up to assure proper initialization. The ADSP-21991 contains an integrated power-on reset (POR) circuit that provides an output reset signal, $\overline{\text{POR}}$, from the ADSP-21991 on power-up and if the power supply voltage falls below the threshold level. The ADSP-21991 may be reset from an external source using the $\overline{\text{RESET}}$ signal, or alternatively, the internal power-on reset circuit may be used by connecting the $\overline{\text{POR}}$ pin to the $\overline{\text{RESET}}$ pin. During power-up the $\overline{\text{RESET}}$ line must be activated for long enough to allow the DSP core's internal clock to stabilize. The power-up sequence is defined as the total time required for the crystal oscillator to stabilize after a valid VDD is applied to the processor and for the internal phase-locked loop (PLL) to lock onto the specific crystal frequency. A minimum of 512 cycles will ensure that the PLL has locked (this does not include the crystal oscillator start-up time).

The $\overline{\text{RESET}}$ input contains some hysteresis. If an RC circuit is used to generate the $\overline{\text{RESET}}$ signal, the circuit should use an external Schmitt trigger.

The master reset sets all internal stack pointers to the empty stack condition, masks all interrupts, and resets all registers to their default values (where applicable). When $\overline{\text{RESET}}$ is released, if there is no pending bus request, program control jumps to the location of the on-chip boot ROM (0xFF0000) and the booting sequence is performed.

Power Supplies

The ADSP-21991 has separate power supply connections for the internal (V_{DDINT}) and external (V_{DDEXT}) power supplies. The internal supply must meet the 2.5 V requirement. The external supply must be connected to a 3.3 V supply. All external supply pins must be connected to the same supply. The ideal power-on sequence for the DSP is to provide power-up of all supplies simultaneously. If there is going to be some delay in power-up between the supplies, provide V_{DD} first, then V_{DDIO} .

Booting Modes

The ADSP-21991 supports a number of different boot modes that are controlled by the three dedicated hardware boot mode control pins (BMODE2, BMODE1, and BMODE0). The use of three boot mode control pins means that up to eight different boot modes are possible. Of these only five modes are valid on the ADSP-21991. The ADSP-21991 exposes the boot mechanism to software control by providing a nonmaskable boot interrupt that vectors to the start of the on-chip ROM memory block (at address 0xFF0000). A boot interrupt is automatically initiated following either a hardware initiated reset, via the

$\overline{\text{RESET}}$ pin, or a software initiated reset, via writing to the Software Reset register. Following either a hardware or a software reset, execution always starts from the boot ROM at address 0xFF0000, irrespective of the settings of the BMODE2, BMODE1, and BMODE0 pins. The dedicated BMODE2, BMODE1, and BMODE0 pins are sampled at hardware reset.

The particular boot mode for the ADSP-21991 associated with the settings of the BMODE2, BMODE1, BMODE0 pins is defined in [Table 3](#).

Table 3. Summary of Boot Modes

Boot Mode	BMODE2	BMODE1	BMODE0	Function
0	0	0	0	Illegal – Reserved
1	0	0	1	Boot from External 8-bit Memory over EMI
2	0	1	0	Execute from External 8-bit Memory
3	0	1	1	Execute from External 16-bit Memory
4	1	0	0	Boot from SPI \leq 4K bits
5	1	0	1	Boot from SPI $>$ 4K bits
6	1	1	0	Illegal – Reserved
7	1	1	1	Illegal – Reserved

Instruction Set Description

The ADSP-21991 assembly language instruction set has an algebraic syntax that was designed for ease of coding and readability. The assembly language, which takes full advantage of the unique architecture of the processor, offers the following benefits:

- ADSP-219x assembly language syntax is a superset of and source code compatible (except for two data registers and DAG base address registers) with ADSP-21xx family syntax. It may be necessary to restructure ADSP-21xx programs to accommodate the unified memory space of the ADSP-21991 and to conform to its interrupt vector map.
- The algebraic syntax eliminates the need to remember cryptic assembler mnemonics. For example, a typical arithmetic add instruction, such as $\text{AR} = \text{AX0} + \text{AY0}$, resembles a simple equation.
- Every instruction, but two, assembles into a single, 24-bit word that can execute in a single instruction cycle. The exceptions are two dual word instructions. One writes 16-bit or 24-bit immediate data to memory, and the other is an absolute jump/call with the 24-bit address specified in the instruction.
- Multifunction instructions allow parallel execution of an arithmetic, MAC, or shift instruction with up to two fetches or one write to processor memory space during a single instruction cycle.
- Program flow instructions support a wider variety of conditional and unconditional jumps/calls and a larger set of conditions on which to base execution of conditional instructions.

Development Tools

The ADSP-21991 is supported with a complete set of CROSSCORE™ software and hardware development tools, including Analog Devices emulators and VisualDSP++™ development environment. The emulator hardware that supports other ADSP-219x DSPs also fully emulates the ADSP-21991.

The VisualDSP++ project management environment lets programmers develop and debug an application. This environment includes an easy to use assembler (which is based on an algebraic syntax), an archiver (librarian/library builder), a linker, a loader, a cycle-accurate instruction-level simulator, a C/C++ compiler, and a C/C++ runtime library that includes DSP and mathematical functions. A key point for these tools is C/C++ code efficiency. The compiler has been developed for efficient translation of C/C++ code to DSP assembly. The DSP has architectural features that improve the efficiency of compiled C/C++ code.

The VisualDSP++ debugger has a number of important features. Data visualization is enhanced by a plotting package that offers a significant level of flexibility. This graphical representation of user data enables the programmer to quickly determine the performance of an algorithm. As algorithms grow in complexity, this capability can have increasing influence on the design development schedule, increasing productivity. Statistical profiling enables the programmer to nonintrusively poll the processor as it is running the program. This feature, unique to VisualDSP++, enables the software developer to passively gather important code execution metrics without interrupting the real-time characteristics of the program. Essentially, the developer can identify bottlenecks in software quickly and efficiently. By using the profiler, the programmer can focus on those areas in the program that impact performance and take corrective action.

ADSP-21991

Debugging both C/C++ and assembly programs with the VisualDSP++ debugger, programmers can:

- View mixed C/C++ and assembly code (interleaved source and object information)
- Insert breakpoints
- Set conditional breakpoints on registers, memory, and stacks
- Trace instruction execution
- Perform linear or statistical profiling of program execution
- Fill, dump, and graphically plot the contents of memory
- Perform source level debugging
- Create custom debugger windows

The VisualDSP++ IDDE lets programmers define and manage DSP software development. Its dialog boxes and property pages let programmers configure and manage all of the ADSP-219x development tools, including the color syntax highlighting in the VisualDSP++ editor. This capability permits programmers to:

- Control how the development tools process inputs and generate outputs
- Maintain a one-to-one correspondence with the command line switches of the tool

The VisualDSP++ Kernel (VDK) incorporates scheduling and resource management tailored specifically to address the memory and timing constraints of DSP programming. These capabilities enable engineers to develop code more effectively, eliminating the need to start from the very beginning, when developing new application code. The VDK features include Threads, Critical and Unscheduled regions, Semaphores, Events, and Device flags. The VDK also supports Priority-based, Preemptive, Cooperative, and Time-Sliced scheduling approaches. In addition, the VDK was designed to be scalable. If the application does not use a specific feature, the support code for that feature is excluded from the target system.

Because the VDK is a library, a developer can decide whether to use it or not. The VDK is integrated into the VisualDSP++ development environment, but can also be used via standard command line tools. When the VDK is used, the development environment assists the developer with many error-prone tasks and assists in managing system resources, automating the generation of various VDK based objects, and visualizing the system state, when debugging an application that uses the VDK.

VCSE is Analog Devices technology for creating, using, and reusing software components (independent modules of substantial functionality) to quickly and reliably assemble software applications. Download components from the Web and drop them into the application. Publish component archives from within VisualDSP++. VCSE supports component implementation in C/C++ or assembly language.

Use the Expert Linker to visually manipulate the placement of code and data on the embedded system. View memory utilization in a color-coded graphical form, easily move code and data to different areas of the DSP or external memory with the drag of the mouse, examine run time stack and heap usage. The Expert

Linker is fully compatible with existing Linker Definition File (LDF), allowing the developer to move between the graphical and textual environments.

Analog Devices DSP emulators use the IEEE 1149.1 JTAG Test Access Port of the ADSP-21991 processor to monitor and control the target board processor during emulation. The emulator provides full speed emulation, allowing inspection and modification of memory, registers, and processor stacks. Non intrusive in-circuit emulation is assured by the use of the processor JTAG interface—target system loading and timing are not affected by the emulator.

In addition to the software and hardware development tools available from Analog Devices, third parties provide a wide range of tools supporting the ADSP-219x processor family. Hardware tools include ADSP-219x DSP PC plug-in cards. Third party software tools include DSP libraries, real-time operating systems, and block diagram design tools.

Designing an Emulator-Compatible DSP Board

The Analog Devices family of emulators are tools that every DSP developer needs to test and debug hardware and software systems. Analog Devices has supplied an IEEE 1149.1 JTAG Test Access Port (TAP) on each JTAG DSP. The emulator uses the TAP to access the internal features of the DSP, allowing the developer to load code, set breakpoints, observe variables, observe memory, and examine registers. The DSP must be halted to send data and commands, but once an operation has been completed by the emulator, the DSP system is set running at full speed with no impact on system timing.

To use these emulators, the target board must include a header that connects the JTAG port of the DSP to the emulator.

For details on target board design issues including mechanical layout, single processor connections, multiprocessor scan chains, signal buffering, signal termination, and emulator pod logic, see the *EE-68: Analog Devices JTAG Emulation Technical Reference* on the Analog Devices website (www.analog.com)—use site search on “EE-68.” This document is updated regularly to keep pace with improvements to emulator support.

Additional Information

This data sheet provides a general overview of the ADSP-21991 architecture and functionality. For detailed information on the ADSP-21991 embedded DSP core architecture, instruction set, communications ports and embedded control peripherals, refer to the *ADSP-2199x Mixed Signal DSP Controller Hardware Reference*.

PIN FUNCTION DESCRIPTIONS

ADSP-21991 pin definitions are listed in [Table 4](#). All ADSP-21991 inputs are asynchronous and can be asserted asynchronously to CLKIN (or to TCK for $\overline{\text{TRST}}$).

Unused inputs should be tied or pulled to V_{DDEXT} or GND, except for ADDR21–0, DATA15–0, PF7–0, and inputs that have internal pull-up or pull-down resistors ($\overline{\text{TRST}}$, BMODE0, BMODE1, BMODE2, BYPASS, TCK, TMS, TDI, PWMPOL, PWMSR, and $\overline{\text{RESET}}$)—these pins can be left floating. These

pins have a logic level hold circuit that prevents input from floating internally. $\overline{\text{PWMTRIP}}$ has an internal pull-down, but should not be left floating to avoid unnecessary PWM shutdowns.

The following symbols appear in the Type column of [Table 4](#):
 G = Ground, I = Input, O = Output, P = Power Supply,
 B = Bidirectional, T = Three-State, D = Digital, A = Analog,
 CKG = Clock Generation pin, PU = Internal Pull-up, and
 PD = Internal Pull-Down.

Table 4. Pin Descriptions

Pin	Type	Function
A19-0	D, OT	External Port Address Bus
D15-0	D, BT	External Port Data Bus
$\overline{\text{RD}}$	D, OT	External Port Read Strobe
$\overline{\text{WR}}$	D, OT	External Port Write Strobe
ACK	D, I	External Port Access Ready Acknowledge
$\overline{\text{BR}}$	D, I, PU	External Port Bus Request
$\overline{\text{BG}}$	D, O	External Port Bus Grant
$\overline{\text{BGH}}$	D, O	External Port Bus Grant Hang
$\overline{\text{MS0}}$	D, OT	External Port Memory Select Strobe 0
$\overline{\text{MS1}}$	D, OT	External Port Memory Select Strobe 1
$\overline{\text{MS2}}$	D, OT	External Port Memory Select Strobe 2
$\overline{\text{MS3}}$	D, OT	External Port Memory Select Strobe 3
$\overline{\text{IOMS}}$	D, OT	External Port IO Space Select Strobe
$\overline{\text{BMS}}$	D, OT	External Port Boot Memory Select Strobe
CLKIN	D, I, CKG	Clock Input/Oscillator Input/Crystal Connection 0
XTAL	D, O, CKG	Oscillator Output/Crystal Connection 1
CLKOUT	D, O	Clock Output (HCLK)
BYPASS	D, I, PU	PLL Bypass Mode Select
$\overline{\text{RESET}}$	D, I, PU	Processor Reset Input
$\overline{\text{POR}}$	D, O	Power on Reset Output
BMODE2	D, I, PU	Boot Mode Select Input 2
BMODE1	D, I, PD	Boot Mode Select Input 1
BMODE0	D, I, PU	Boot Mode Select Input 0
TCK	D, I	JTAG Test Clock
TMS	D, I, PU	JTAG Test Mode Select
TDI	D, I, PU	JTAG Test Data Input
TDO	D, OT	JTAG Test Data Output
$\overline{\text{TRST}}$	D, I, PU	JTAG Test Reset Input
$\overline{\text{EMU}}$	D, OT, PU	Emulation Status
VIN0	A, I	ADC Input 0
VIN1	A, I	ADC Input 1
VIN2	A, I	ADC Input 2
VIN3	A, I	ADC Input 3
VIN4	A, I	ADC Input 4
VIN5	A, I	ADC Input 5
VIN6	A, I	ADC Input 6
VIN7	A, I	ADC Input 7
ASHAN	A, I	Inverting SHA_A Input
BSHAN	A, I	Inverting SHA_B Input
CAPT	A, O	Noise Reduction Pin
CAPB	A, O	Noise Reduction Pin
VREF	A, I, O	Voltage Reference Pin (Mode Selected by State of SENSE)
SENSE	A, I	Voltage Reference Select Pin
CML	A, O	Common-Mode Level Pin
CONVST	D, I	ADC Convert Start Input
PF15	D, BT, PD	General-Purpose IO15
PF14	D, BT, PD	General-Purpose IO14
PF13	D, BT, PD	General-Purpose IO13

ADSP-21991

Table 4. Pin Descriptions (Continued)

Pin	Type	Function
PF12	D, BT, PD	General-Purpose IO12
PF11	D, BT, PD	General-Purpose IO11
PF10	D, BT, PD	General-Purpose IO10
PF9	D, BT, PD	General-Purpose IO9
PF8	D, BT, PD	General-Purpose IO8
PF7/SPISEL7	D, BT, PD	General-Purpose IO7/SPI Slave Select Output 7
PF6/SPISEL6	D, BT, PD	General-Purpose IO6/SPI Slave Select Output 6
PF5/SPISEL5	D, BT, PD	General-Purpose IO5/SPI Slave Select Output 5
PF4/SPISEL4	D, BT, PD	General-Purpose IO4/SPI Slave Select Output 4
PF3/SPISEL3	D, BT, PD	General-Purpose IO3/SPI Slave Select Output 3
PF2/SPISEL2	D, BT, PD	General-Purpose IO2/SPI Slave Select Output 2
PF1/SPISEL1	D, BT, PD	General-Purpose IO1/SPI Slave Select Output 1
PF0/SPISS	D, BT, PD	General-Purpose IO0/SPI Slave Select Input 0
SCK	D, BT	SPI Clock
MISO	D, BT	SPI Master In Slave Out Data
MOSI	D, BT	SPI Master Out Slave In Data
DT	D, OT	SPORT Data Transmit
DR	D, I	SPORT Data Receive
RFS	D, BT	SPORT Receive Frame Sync
TFS	D, BT	SPORT Transmit Frame Sync
TCLK	D, BT	SPORT Transmit Clock
RCLK	D, BT	SPORT Receive Clock
EIA	D, I	Encoder A Channel Input
EIB	D, I	Encoder B Channel Input
EIZ	D, I	Encoder Z Channel Input
EIS	D, I	Encoder S Channel Input
AUX0	D, O	Auxiliary PWM Channel 0 Output
AUX1	D, O	Auxiliary PWM Channel 1 Output
<u>AUXTRIP</u>	D, I, PD	Auxiliary PWM Shutdown Pin
TMR2	D, BT	Timer 0 Input/Output Pin
TMR1	D, BT	Timer 1 Input/Output Pin
TMR0	D, BT	Timer 2 Input/Output Pin
AH	D, O	PWM Channel A HI PWM
AL	D, O	PWM Channel A LO PWM
BH	D, O	PWM Channel B HI PWM
BL	D, O	PWM Channel B LO PWM
CH	D, O	PWM Channel C HI PWM
CL	D, O	PWM Channel C LO PWM
PWMSYNC	D, BT	PWM Synchronization
PWMPOL	D, I, PU	PWM Polarity
<u>PWMTRIP</u>	D, I, PD	PWM Trip
<u>PWMSR</u>	D, I, PU	PWM SR Mode Select
AVDD (2 pins)	A, P	Analog Supply Voltage
AVSS (2 pins)	A, G	Analog Ground
VDDINT (6 pins)	D, P	Digital Internal Supply
VDDEXT (10 pins)	D, P	Digital External Supply
GND (16 pins)	D, G	Digital Ground

SPECIFICATIONS

Specifications subject to change without notice.

RECOMMENDED OPERATING CONDITIONS—ADSP-21991BBC

Parameter		Min	Typ	Max	Unit
V _{DDINT}	Internal (Core) Supply Voltage	2.375	2.5	2.625	V
V _{DDEXT}	External (I/O) Supply Voltage	3.135	3.3	3.465	V
AVDD	Analog Supply Voltage	2.375	2.5	2.625	V
CCLK	DSP Instruction Rate, Core Clock	0		150	MHz
HCLK ^{1,2}	Peripheral Clock Rate	0		75	MHz
CLKIN ³	Input Clock Frequency	0		150	MHz
T _{JUNC} ⁴	Silicon Junction Temperature			+140	°C
T _{AMB}	Ambient Operating Temperature	-40		+85	°C

¹The HCLK frequency may be made to appear at the dedicated CLKOUT pin of the device. For low power operation, however, the CLKOUT pin can be disabled.

²The peripherals operate at the HCLK rate, which may be selected to be equal to CCLK or CCLK÷2, up to a maximum of a 75 MHz HCLK for the ADSP-21991BBC.

³In order to attain the correct CCLK and HCLK values, the input clock frequency or crystal frequency depends on the internal operation of the clock generation PLL circuit and the associated frequency ratio.

⁴The maximum junction temperature is limited to 140°C in order to meet all of the electrical specifications. It is ultimately the responsibility of the user to ensure that the power dissipation of the ADSP-21991 (including all dc and ac loads) is such that the maximum junction temperature limit of 140°C is not exceeded.

RECOMMENDED OPERATING CONDITIONS—ADSP-21991BST

Parameter		Min	Typ	Max	Unit
V _{DDINT}	Internal (Core) Supply Voltage	2.375	2.5	2.625	V
V _{DDEXT}	External (I/O) Supply Voltage	3.135	3.3	3.465	V
AVDD	Analog Supply Voltage	2.375	2.5	2.625	V
CCLK	DSP Instruction Rate, Core Clock	0		160	MHz
HCLK ^{1,2}	Peripheral Clock Rate	0		80	MHz
CLKIN ³	Input Clock Frequency	0		160	MHz
T _{JUNC} ⁴	Silicon Junction Temperature			+140	°C
T _{AMB}	Ambient Operating Temperature	-40		+85	°C

¹The HCLK frequency may be made to appear at the dedicated CLKOUT pin of the device. For low power operation, however, the CLKOUT pin can be disabled.

²The peripherals operate at the HCLK rate, which may be selected to be equal to CCLK or CCLK÷2, up to a maximum of an 80 MHz HCLK for the ADSP-21991BST.

³In order to attain the correct CCLK and HCLK values, the input clock frequency or crystal frequency depends on the internal operation of the clock generation PLL circuit and the associated frequency ratio.

⁴The maximum junction temperature is limited to 140°C in order to meet all of the electrical specifications. It is ultimately the responsibility of the user to ensure that the power dissipation of the ADSP-21991 (including all dc and ac loads) is such that the maximum junction temperature limit of 140°C is not exceeded.

ADSP-21991

ELECTRICAL CHARACTERISTICS—ADSP-21991BBC

Parameter	Test Conditions	Min	Typ	Max	Unit
V _{IH}	High Level Input Voltage ¹	@ V _{DDEXT} = maximum	2.0	V _{DDEXT}	V
V _{IH}	High Level Input Voltage ²	@ V _{DDEXT} = maximum	2.2	V _{DDEXT}	V
V _{IL}	High Level Input Voltage ^{1,2}	@ V _{DDEXT} = minimum		0.8	V
V _{OH}	High Level Output Voltage ³	@ V _{DDEXT} = minimum, I _{OH} = -0.5 mA	2.4		V
V _{OL}	Low Level Output Voltage ³	@ V _{DDEXT} = minimum, I _{OL} = 2.0 mA		0.4	V
I _{IH}	High Level Input Current ⁴	@ V _{DDINT} = maximum, V _{IN} = 3.6 V		10	μA
I _{IH}	High Level Input Current ⁵	@ V _{DDINT} = maximum, V _{IN} = 3.6 V		150	μA
I _{IH}	High Level Input Current ⁶	@ V _{DDINT} = maximum, V _{IN} = 3.6 V		10	μA
I _{IL}	Low Level Input Current	@ V _{DDINT} = maximum, V _{IN} = 0 V		10	μA
I _{IL}	Low Level Input Current	@ V _{DDINT} = maximum, V _{IN} = 0 V		10	μA
I _{IL}	Low Level Input Current	@ V _{DDINT} = maximum, V _{IN} = 0 V		150	μA
I _{OZH}	Three-State Leakage Current ⁷	@ V _{DDINT} = maximum, V _{IN} = 3.6 V		10	μA
I _{OZL}	Three-State Leakage Current ⁷	@ V _{DDINT} = maximum, V _{IN} = 0 V		10	μA
C _I	Input Pin Capacitance	f _{IN} = 1 MHz	10		pF
C _O	Output Pin Capacitance	f _{IN} = 1 MHz	10		pF
I _{DD-PEAK}	Supply Current (Internal) ^{8,9}		190	325	mA
I _{DD-TYP}	Supply Current (Internal) ⁸		155	275	mA
I _{DD-IDLE}	Supply Current (Idle) ⁸		145	250	mA
I _{DD-STOPCLK}	Supply Current (Power-Down) ^{8,10}		60	125	mA
I _{DD-STOPALL}	Supply Current (Power-Down) ^{8,11}		12	40	mA
I _{DD-PDOWN}	Supply Current (Power-Down) ^{8,12}		6	30	mA
I _{AVDD}	Analog Supply Current ¹³		46	65	mA
I _{AVDD-ADCOFF}	Analog Supply Current ¹²		5	15	mA

¹Applies to all input and bidirectional pins.

²Applies to input pins CLKIN, RESET, TRST.

³Applies to all output and bidirectional pins.

⁴Applies to all input only pins.

⁵Applies to input pins with internal pull-down.

⁶Applies to input pins with internal pull-up.

⁷Applies to three-stateable pins.

⁸The I_{DD} supply currents are affected by the operating frequency of the device. The guaranteed numbers are based on an assumed CCLK = 150 MHz, HCLK = 75 MHz for the ADSP-21991BBC. I_{DD} refers only to the current consumption on the internal power supply lines (V_{DDINT}). The current consumption at the I/O on the V_{DDEXT} power supply is very much dependent on the particular connection of the device in the final system.

⁹I_{DD-PEAK} represents worst-case processor operation and is not sustainable under normal application conditions. Actual internal power measurements made using typical applications are less than specified. Measured at V_{DDINT} = maximum.

¹⁰IDLE denotes the current consumption during execution of the IDLE instruction. Measured at V_{DDINT} = maximum.

¹¹I_{DD-PDOWN} represents the processor operation in full power-down mode with both core and peripheral clocks disabled. Measured at V_{DDINT} = maximum.

¹²I_{AVDD} represents the power consumption of the analog system. Measured at AVDD = maximum.

¹³The responsibility lies with the user to ensure that the device is operated in such a manner that the maximum allowable junction temperature is not exceeded.

ELECTRICAL CHARACTERISTICS—ADSP-21991BST

Parameter	Test Conditions	Min	Typ	Max	Unit
V _{IH}	High Level Input Voltage ¹	@ V _{DDEXT} = maximum	2.0	V _{DDEXT}	V
V _{IH}	High Level Input Voltage ²	@ V _{DDEXT} = maximum	2.2	V _{DDEXT}	V
V _{IL}	High Level Input Voltage ^{1,2}	@ V _{DDEXT} = minimum		0.8	V
V _{OH}	High Level Output Voltage ³	@ V _{DDEXT} = minimum, I _{OH} = -0.5 mA	2.4		V
V _{OL}	Low Level Output Voltage ³	@ V _{DDEXT} = minimum, I _{OL} = 2.0 mA		0.4	V
I _{IH}	High Level Input Current ⁴	@ V _{DDINT} = maximum, V _{IN} = 3.6 V		10	μA
I _{IH}	High Level Input Current ⁵	@ V _{DDINT} = maximum, V _{IN} = 3.6 V		150	μA
I _{IH}	High Level Input Current ⁶	@ V _{DDINT} = maximum, V _{IN} = 3.6 V		10	μA
I _{IL}	Low Level Input Current	@ V _{DDINT} = maximum, V _{IN} = 0 V		10	μA
I _{IL}	Low Level Input Current	@ V _{DDINT} = maximum, V _{IN} = 0 V		10	μA
I _{IL}	Low Level Input Current	@ V _{DDINT} = maximum, V _{IN} = 0 V		150	μA
I _{OZH}	Three-State Leakage Current ⁷	@ V _{DDINT} = maximum, V _{IN} = 3.6 V		10	μA
I _{OZL}	Three-State Leakage Current ⁷	@ V _{DDINT} = maximum, V _{IN} = 0 V		10	μA
C _I	Input Pin Capacitance	f _{IN} = 1 MHz	10		pF
C _O	Output Pin Capacitance	f _{IN} = 1 MHz	10		pF
I _{DD-PEAK}	Supply Current (Internal) ^{8,9}		300	350	mA
I _{DD-TYP}	Supply Current (Internal) ⁸		240	300	mA
I _{DD-IDLE}	Supply Current (Idle) ⁸		225	275	mA
I _{DD-STOPCLK}	Supply Current (Power-Down) ^{8,10}		90	150	mA
I _{DD-STOPALL}	Supply Current (Power-Down) ^{8,11}		20	50	mA
I _{DD-PDOWN}	Supply Current (Power-Down) ^{8,12}		7	35	mA
I _{AVDD}	Analog Supply Current ¹³		49	65	mA
I _{AVDD-ADCOFF}	Analog Supply Current ¹²		7	15	mA

¹Applies to all input and bidirectional pins.

²Applies to input pins CLKIN, RESET, TRST.

³Applies to all output and bidirectional pins.

⁴Applies to all input only pins.

⁵Applies to input pins with internal pull-down.

⁶Applies to input pins with internal pull-up.

⁷Applies to three-stateable pins.

⁸The I_{DD} supply currents are affected by the operating frequency of the device. The guaranteed numbers are based on an assumed CCLK=160 MHz, HCLK = 80 MHz for the ADSP-21991BST. I_{DD} refers only to the current consumption on the internal power supply lines (V_{DDINT}). The current consumption at the I/O on the V_{DDEXT} power supply is very much dependent on the particular connection of the device in the final system.

⁹I_{DD-PEAK} represents worst-case processor operation and is not sustainable under normal application conditions. Actual internal power measurements made using typical applications are less than specified. Measured at V_{DDINT} = maximum.

¹⁰IDLE denotes the current consumption during execution of the IDLE instruction. Measured at V_{DDINT} = maximum.

¹¹I_{DD-PDOWN} represents the processor operation in full power-down mode with both core and peripheral clocks disabled. Measured at V_{DDINT} = maximum.

¹²I_{AVDD} represents the power consumption of the analog system. Measured at AVDD = maximum.

¹³The responsibility lies with the user to ensure that the device is operated in such a manner that the maximum allowable junction temperature is not exceeded.

ADSP-21991

PERIPHERALS ELECTRICAL CHARACTERISTICS—ADSP-21991BBC

Parameter		Min	Typ	Max	Unit
ANALOG-TO-DIGITAL CONVERTER					
<i>AC Specifications</i>					
SNR	Signal-to-Noise Ratio ¹	68	72		dB
SNRD	Signal-to-Noise and Distortion ¹	66	71		dB
THD	Total Harmonic Distortion ¹		-80	-66	dB
CTLK	Channel-Channel Crosstalk ¹		-80	-66	dB
CMRR	Common-Mode Rejection Ratio ¹		-82	-66	dB
PSRR	Power Supply Rejection Ratio ¹		0.05	0.2	%FSR
<i>Accuracy</i>					
INL	Integral Nonlinearity ¹		±0.6	±2.0	LSB
DNL	Differential Nonlinearity ¹		±0.5	±1.25	LSB
No missing Codes			12		Bits
Zero Error ¹			1.25	2.5	%FSR
Gain Error ¹			0.5	1.5	%FSR
<i>Input Voltage</i>					
V _{IN}	Input Voltage Span		2.0		V
C _{IN}	Input Capacitance ²		10		pF
<i>Conversion Time</i>					
FCLK	ADC Clock Rate			18.75	MHz
t _{CONV}	Total Conversion Time All 8 Channels			773	ns
VOLTAGE REFERENCE					
Internal Voltage Reference ³		0.94	0.98	1.02	V
Output Voltage Tolerance			40		mV
Output Current			100		μA
Load Regulation ⁴		-2	+0.5	+2	mV
Power Supply Rejection Ratio		-2	+0.5	+2	mV
Reference Input Resistance			8		kΩ
POWER-ON RESET					
V _{RST}	Reset Threshold Voltage	1.4		2.1	V
V _{HYST}	Hysteresis Voltage		50		mV

¹In all cases, the input frequency to the ADC system is assumed to be <100 kHz.

²Analog Input Pins VIN0 to VIN7.

³These specifications are for operation of the internal voltage reference so that SENSE = REFCOM, with the default 1.0 V operating mode.

⁴Operation with full 0.1 mA load current. For optimal operation, it is recommended to buffer the VREF output voltage before using it in other parts of the system.

PERIPHERALS ELECTRICAL CHARACTERISTICS—ADSP-21991BST

Parameter		Min	Typ	Max	Unit
ANALOG-TO-DIGITAL CONVERTER					
<i>AC Specifications</i>					
SNR	Signal-to-Noise Ratio ¹	68	72		dB
SNRD	Signal-to-Noise and Distortion ¹	68	71		dB
THD	Total Harmonic Distortion ¹		-78	-68	dB
CTLK	Channel-Channel Crosstalk ¹		-80	-66	dB
CMRR	Common-Mode Rejection Ratio ¹		-74	-66	dB
PSRR	Power Supply Rejection Ratio ¹		0.05	0.2	%FSR
<i>Accuracy</i>					
INL	Integral Nonlinearity ¹		±0.6	±2.0	LSB
DNL	Differential Nonlinearity ¹		±0.5	±1.25	LSB
No missing Codes			12		Bits
Zero Error ¹			1.25	2.5	%FSR
Gain Error ¹			0.5	1.5	%FSR
<i>Input Voltage</i>					
V _{IN}	Input Voltage Span		2.0		V
C _{IN}	Input Capacitance ²		10		pF
<i>Conversion Time</i>					
FCLK	ADC Clock Rate			20	MHz
t _{CONV}	Total Conversion Time All 8 Channels			725	ns
VOLTAGE REFERENCE					
Internal Voltage Reference ³		0.94	0.98	1.02	V
Output Voltage Tolerance			40		mV
Output Current			100		μA
Load Regulation ⁴		-2	+0.5	+2	mV
Power Supply Rejection Ratio		-2	+0.5	+2	mV
Reference Input Resistance			8		kΩ
POWER ON RESET					
V _{RST}	Reset Threshold Voltage	1.4		2.1	V
V _{HYST}	Hysteresis Voltage		50		mV

¹In all cases, the input frequency to the ADC system is assumed to be <100 kHz.

²Analog Input Pins VIN0 to VIN7.

³These specifications are for operation of the internal voltage reference so that SENSE = REFCOM, with the default 1.0 V operating mode.

⁴Operation with full 0.1 mA load current. For optimal operation, it is recommended to buffer the VREF output voltage before using it in other parts of the system.

ADSP-21991

ABSOLUTE MAXIMUM RATINGS

Internal (Core) Supply Voltage ¹ (V_{DDINT}) . . .	-0.3 V to +3.0 V
External (I/O) Supply Voltage ¹ (V_{DDEXT}) . . .	-0.3 V to +4.6 V
Input Voltage ^{1, 2} ($V_{IL}-V_{IH}$)	-0.5 V to +5.5 V
Output Voltage Swing ^{1, 2} ($V_{OL}-V_{OH}$)	-0.5 V to +5.5 V
Load Capacitance ¹ (C_L)	200 pF
Core Clock Period ¹ (t_{CCLK})	6.25 ns
Core Clock Frequency ¹ (f_{CCLK})	160 MHz
Peripheral Clock Period ¹ (t_{HCLK})	12.5 ns
Peripheral Clock Frequency ¹ (f_{HCLK})	80 MHz
Storage Temperature Range ¹ (T_{STORE})	-65°C to +150°C
Lead Temperature (5 seconds) ¹ (T_{LEAD})	185°C

¹Stresses greater than those listed above may cause permanent damage to the device. These are stress ratings only; functional operation of the device at these or any other conditions greater than those indicated in the operational sections of this specification is not implied. Exposure to absolute maximum rating conditions for extended periods may affect device reliability.

²Except CLKIN and analog pins.

ESD SENSITIVITY

CAUTION

ESD (electrostatic discharge) sensitive device. Electrostatic charges as high as 4000 V readily accumulate on the human body and test equipment and can discharge without detection. Although the ADSP-21991 features proprietary ESD protection circuitry, permanent damage may occur on devices subjected to high energy electrostatic discharges. Therefore, proper ESD precautions are recommended to avoid performance degradation or loss of functionality.



TIMING SPECIFICATIONS

This section contains timing information for the DSP external signals. Use the exact information given. Do not attempt to derive parameters from the addition or subtraction of other information. While addition or subtraction would yield meaningful results for an individual device, the values given in this data sheet reflect statistical variations and worst cases. Consequently, parameters cannot be added meaningfully to derive longer times.

Switching characteristics specify how the processor changes its signals. No control is possible over this timing; circuitry external to the processor must be designed for compatibility with these

signal characteristics. Switching characteristics indicate what the processor will do in a given circumstance. Switching characteristics can also be used to ensure that any timing requirement of a device connected to the processor (such as memory) is satisfied.

Timing requirements apply to signals that are controlled by circuitry external to the processor, such as the data input for a read operation. Timing requirements guarantee that the processor operates correctly with other devices.

Clock In and Clock Out Cycle Timing

Table 5 and Figure 6 describe clock and reset operations. Combinations of CLKIN and clock multipliers must not select core/peripheral clocks in excess of 160 MHz/80 MHz for the ADSP-21991BST and 150 MHz/75 MHz for the ADSP-21991BBC, when the peripheral clock rate is one-half the core clock rate. If the peripheral clock rate is equal to the core clock

rate, the maximum peripheral clock rate is 80 MHz for the ADSP-21991BST and 75 MHz for the ADSP-21991BBC. The peripheral clock is supplied to the CLKOUT pins.

When changing from bypass mode to PLL mode, allow 512 HCLK cycles for the PLL to stabilize.

Table 5. Clock In and Clock Out Cycle Timing

Parameter		Min	Max	Unit
<i>Timing Requirements</i>				
t_{CK}	CLKIN Period ^{1, 2}	10	200	ns
t_{CKL}	CLKIN Low Pulse	4.5		ns
t_{CKH}	CLKIN High Pulse	4.5		ns
t_{WRST}	RESET Asserted Pulsewidth Low	$200t_{CLKOUT}$		ns
t_{MSS}	MSELx/BYPASS Stable Before RESET Deasserted Setup	40		μ s
t_{MSH}	MSELx/BYPASS Stable After RESET Deasserted Hold	1000		ns
t_{MSD}	MSELx/BYPASS Stable After RESET Asserted		200	ns
t_{PFD}	Flag Output Disable Time After RESET Asserted		10	ns
<i>Switching Characteristics</i>				
t_{CKOD}	CLKOUT Delay from CLKIN	0	5.8	ns
t_{CKO}	CLKOUT Period ³	12.5		ns

¹In clock multiplier mode and MSEL6-0 set for 1:1 (or CLKIN = CCLK), $t_{CK} = t_{CCLK}$.

²In bypass mode, $t_{CK} = t_{CCLK}$.

³CLKOUT jitter can be as great as 8 ns when CLKOUT frequency is less than 20 MHz. For frequencies greater than 20 MHz, jitter is less than 1 ns.

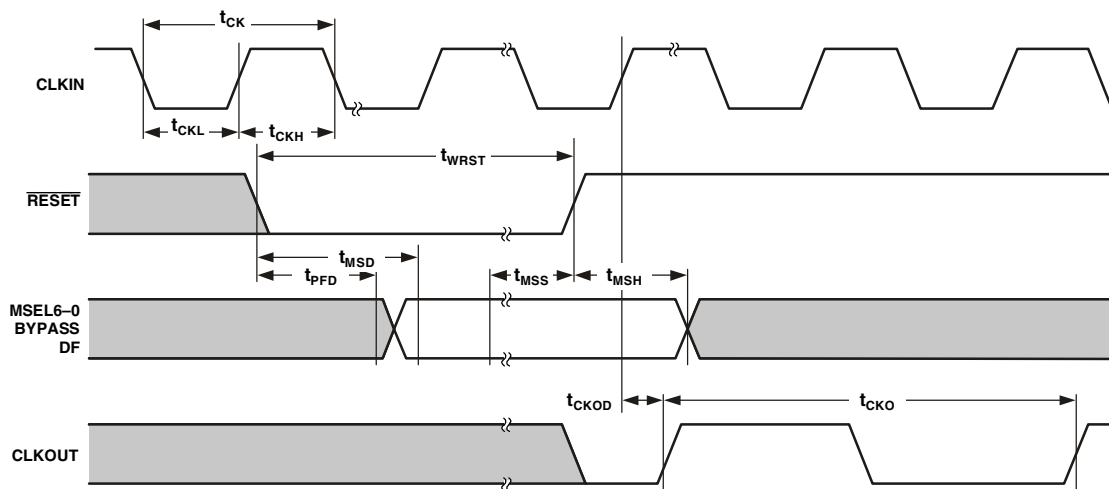

Figure 6. Clock In and Clock Out Cycle Timing

ADSP-21991

Programmable Flags Cycle Timing

Table 6 and Figure 7 describe Programmable Flag operations.

Table 6. Programmable Flags Cycle Timing

Parameter	Min	Max	Unit
<i>Timing Requirement</i>			
t_{HFI} Flag Input Hold is Asynchronous	3		ns
<i>Switching Characteristics</i>			
t_{DFO} Flag Output Delay with Respect to CLKOUT		7	ns
t_{HFO} Flag Output Hold After CLKOUT High		6	ns

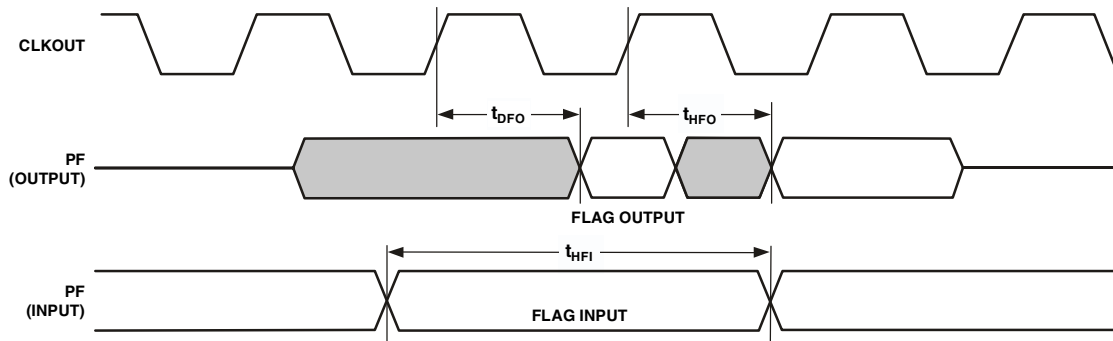

Figure 7. Programmable Flags Cycle Timing

Timer PWM_OUT Cycle Timing

Table 7 and Figure 8 describe timer expired operations. The input signal is asynchronous in “width capture mode” and has an absolute maximum input frequency of 40 MHz.

Table 7. Timer PWM_OUT Cycle Timing

Parameter	Min	Max	Unit
<i>Switching Characteristic</i>			
t_{HTO} Timer Pulsewidth Output ¹	12.5	$(2^{32}-1)$ cycles	ns

¹The minimum time for t_{HTO} is one cycle, and the maximum time for t_{HTO} equals $(2^{32}-1)$ cycles.

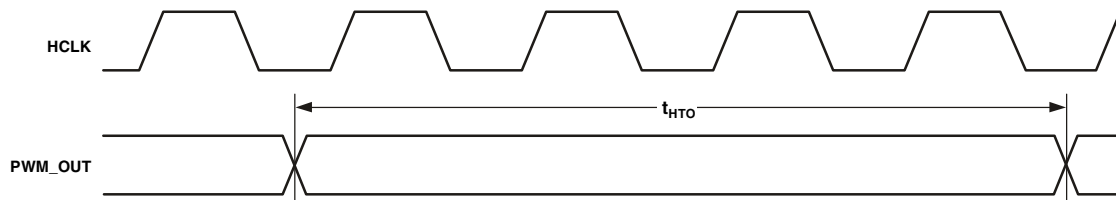

Figure 8. Timer PWM_OUT Cycle Timing

ADSP-21991

External Port Write Cycle Timing

Table 8 and Figure 9 describe external port write operations.

The external port lets systems extend read/write accesses in three ways: wait states, ACK input, and combined wait states and ACK. To add waits with ACK, the DSP must see ACK low at

the rising edge of EMI clock. ACK low causes the DSP to wait, and the DSP requires two EMI clock cycles after ACK goes high to finish the access. For more information, see the External Port chapter in the *ADSP-2199x DSP Hardware Reference*.

Table 8. External Port Write Cycle Timing

Parameter ^{1, 2}	Min	Max	Unit
<i>Timing Requirements</i>			
t_{AKW} ACK Strobe Pulsewidth	12.5		ns
t_{DWSAK} ACK Delay from \overline{XMS} Low		$0.5t_{EMICLK}-1$	ns
<i>Switching Characteristics</i>			
t_{CSWS} Chip Select Asserted to \overline{WR} Asserted Delay	$0.5t_{EMICLK}-4$		ns
t_{AWS} Address Valid to \overline{WR} Setup and Delay	$0.5t_{EMICLK}-3$		ns
t_{WSCS} \overline{WR} Deasserted to Chip Select Deasserted	$0.5t_{EMICLK}-4$		ns
t_{WSA} \overline{WR} Deasserted to Address Invalid	$0.5t_{EMICLK}-3$		ns
t_{WW} \overline{WR} Strobe Pulsewidth	$t_{EMICLK}-2+W^3$		ns
t_{CDA} \overline{WR} to Data Enable Access Delay		0	ns
t_{CDD} \overline{WR} to Data Disable Access Delay	$0.5t_{EMICLK}-3$	$0.5t_{EMICLK}+4$	ns
t_{DSW} Data Valid to \overline{WR} Deasserted Setup	$t_{EMICLK}+1+W^3$	$t_{EMICLK}+7+W^3$	ns
t_{DHW} \overline{WR} Deasserted to Data Invalid Hold Time; $E_WHC^{4, 5}$	3.4		ns
t_{DHW} \overline{WR} Deasserted to Data Invalid Hold Time; $E_WHC^{4, 6}$	$t_{EMICLK}+3.4$		ns
t_{WWR} \overline{WR} Deasserted to \overline{WR} , \overline{RD} Asserted	t_{HCLK}		ns

¹ t_{EMICLK} is the External Memory Interface clock period. t_{HCLK} is the peripheral clock period.

² These are timing parameters that are based on worst-case operating conditions.

³ $W = (\text{number of wait states specified in wait register}) \times t_{EMICLK}$.

⁴ Write hold cycle-memory select control registers ($MS \times CTL$).

⁵ Write wait state count (E_WWC) = 0

⁶ Write wait state count (E_WWC) = 1

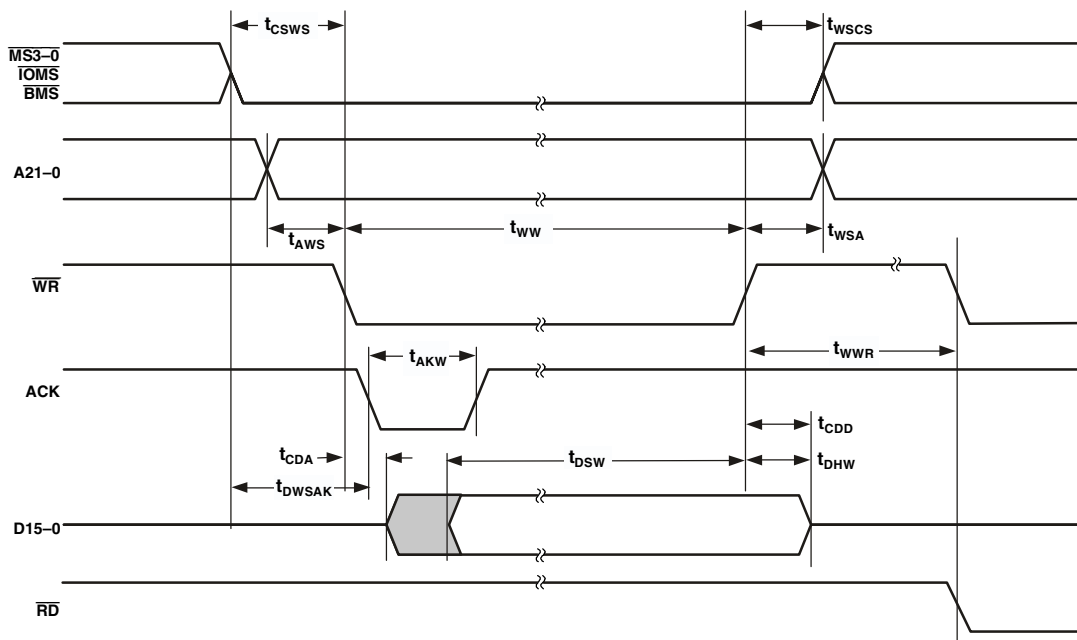

Figure 9. External Port Write Cycle Timing

External Port Read Cycle Timing

Table 9 and Figure 10 describe external port read operations. For additional information on the ACK signal, see the discussion on Page 26.

Table 9. External Port Read Cycle Timing

Parameter ^{1, 2}	Min	Max	Unit
<i>Timing Requirements</i>			
t_{AKW} ACK Strobe Pulsewidth	t_{HCLK}		ns
t_{RDA} \overline{RD} Asserted to Data Access Setup		$t_{EMICLK} - 5 + W^3$	ns
t_{ADA} Address Valid to Data Access Setup		$t_{EMICLK} + W^3$	ns
t_{SDA} Chip Select Asserted to Data Access Setup		$t_{EMICLK} + W^3$	ns
t_{SD} Data Valid to \overline{RD} Deasserted Setup	5		ns
t_{HRD} \overline{RD} Deasserted to Data Invalid Hold	0		ns
t_{DRSAK} ACK Delay from \overline{XMS} Low		$0.5t_{EMICLK} - 1$	ns
<i>Switching Characteristics</i>			
t_{CSRS} Chip Select Asserted to \overline{RD} Asserted Delay	$0.5t_{EMICLK} - 3$		ns
t_{ARS} Address Valid to \overline{RD} Setup and Delay	$0.5t_{EMICLK} - 3$		ns
t_{RSCS} \overline{RD} Deasserted to Chip Select Deasserted Setup	$0.5t_{EMICLK} - 2$		ns
t_{RW} \overline{RD} Strobe Pulsewidth	$t_{EMICLK} - 2 + W^3$		ns
t_{RSA} \overline{RD} Deasserted to Address Invalid Setup	$0.5t_{HCLK} - 2$		ns
t_{RWR} \overline{RD} Deasserted to \overline{WR} , \overline{RD} Asserted	t_{HCLK}		ns

¹ t_{EMICLK} is the External Memory Interface clock period. t_{HCLK} is the peripheral clock period.

² These are timing parameters that are based on worst-case operating conditions.

³ $W = (\text{number of wait states specified in wait register}) \times t_{EMICLK}$.

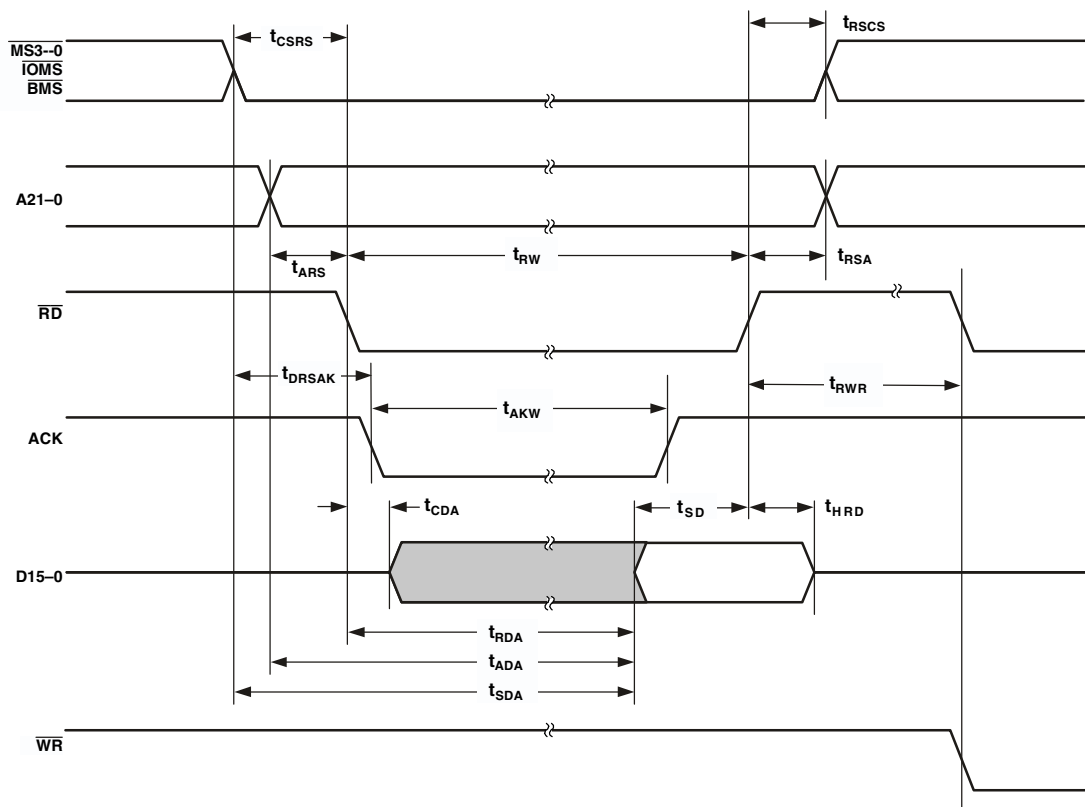

Figure 10. External Port Read Cycle Timing

ADSP-21991

External Port Bus Request/Grant Cycle Timing

Table 10 and Figure 11 describe external port bus request and bus grant operations.

Table 10. External Port Bus Request and Grant Cycle Timing

Parameter ^{1, 2}	Min	Max	Unit
<i>Timing Requirements</i>			
t_{BS}	4.6		ns
t_{BH}	0		ns
<i>Switching Characteristics</i>			
t_{SD}		$0.5t_{HCLK} + 1$	ns
t_{SE}	0	4	ns
t_{DBG}	0	4	ns
t_{EBG}	0	4	ns
t_{DBH}	0	4	ns
t_{EBH}	0	4	ns

¹ t_{HCLK} is the peripheral clock period.

² These are timing parameters that are based on worst-case operating conditions.

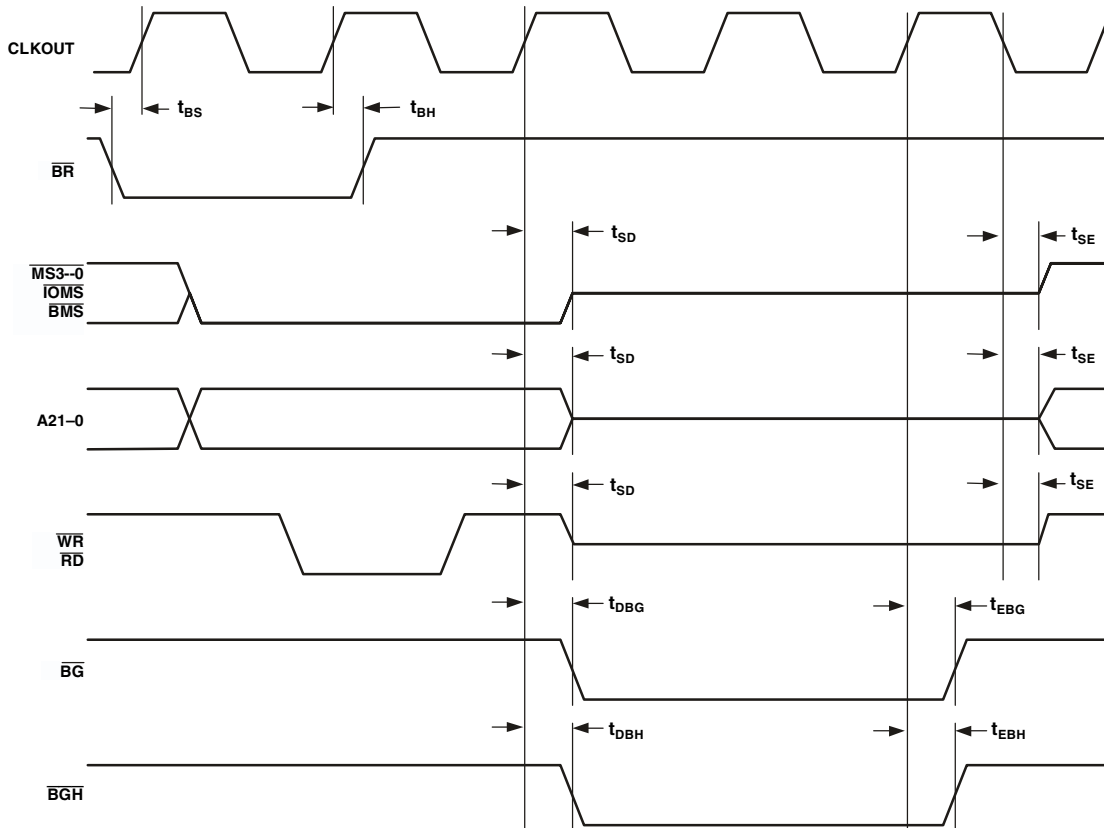

Figure 11. External Port Bus Request and Grant Cycle Timing

Serial Port Timing

Table 11 and Figure 12 describe SPORT transmit and receive operations, while Figure 13 and Figure 14 describe SPORT Frame Sync operations.

Table 11. Serial Port^{1,2}

Parameter	Min	Max	Unit
<i>External Clock Timing Requirements</i>			
t _{SFSE} TFS/RFS Setup Before TCLK/RCLK ³	4		ns
t _{HFSE} TFS/RFS Hold After TCLK/RCLK ³	4		ns
t _{SDRE} Receive Data Setup Before RCLK ³	1.5		ns
t _{HDRE} Receive Data Hold After RCLK ³	4		ns
t _{SCLKW} TCLK/RCLK Width	0.5t _{HCLK} -1		ns
t _{SCLK} TCLK/RCLK Period	2t _{HCLK}		ns
<i>Internal Clock Timing Requirements</i>			
t _{SFSI} TFS Setup Before TCLK ⁴ ; RFS Setup Before RCLK ³	4		ns
t _{HFSI} TFS/RFS Hold After TCLK/RCLK ³	3		ns
t _{SDRI} Receive Data Setup Before RCLK ³	2		ns
t _{HDRI} Receive Data Hold After RCLK ³	5		ns
<i>External or Internal Clock Switching Characteristics</i>			
t _{DFSE} TFS/RFS Delay After TCLK/RCLK (Internally Generated FS) ⁴		14	ns
t _{HOFSE} TFS/RFS Hold After TCLK/RCLK (Internally Generated FS) ⁴	3		ns
<i>External Clock Switching Characteristics</i>			
t _{DDTE} Transmit Data Delay After TCLK ⁴		13.4	ns
t _{HDTE} Transmit Data Hold After TCLK ⁴	4		ns
<i>Internal Clock Switching Characteristics</i>			
t _{DDTI} Transmit Data Delay After TCLK ⁴		13.4	ns
t _{HDTI} Transmit Data Hold After TCLK ⁴	4		ns
t _{SCLKIW} TCLK/RCLK Width	0.5t _{HCLK} -3.5	0.5t _{HCLK} +2.5	ns
<i>Enable and Three-State⁵ Switching Characteristics</i>			
t _{DTENE} Data Enable from External TCLK ⁴	0	12.1	ns
t _{DDTTE} Data Disable from External TCLK ⁴		13	ns
t _{DTENI} Data Enable from Internal TCLK ⁴	0	13	ns
t _{DDTTI} Data Disable from External TCLK ⁴		12	ns
<i>External Late Frame Sync Switching Characteristics</i>			
t _{DDTLFSE} Data Delay from Late External TFS with MCE=1, MFD=0 ^{6,7}		10.5	ns
t _{DTENLFSE} Data Enable from Late FS or MCE=1, MFD=0 ^{6,7}	3.5		ns

¹To determine whether communication is possible between two devices at clock speed n, the following specifications must be confirmed: 1) frame sync delay and frame sync setup-and-hold, 2) data delay and data setup-and-hold, and 3) SCLK width.

²Word selected timing for I²S mode is the same as TFS/RFS timing (normal framing only).

³Referenced to sample edge.

⁴Referenced to drive edge.

⁵Only applies to SPORT.

⁶MCE=1, TFS enable, and TFS valid follow t_{DDTENFS} and t_{DDTLFSE}.

⁷If external RFS/D/TFS setup to RCLK/TCLK > 0.5t_{LCLK}, t_{DDTLCK} and t_{DTENLCK} apply; otherwise, t_{DDTLFSE} and t_{DTENLFS} apply.

ADSP-21991

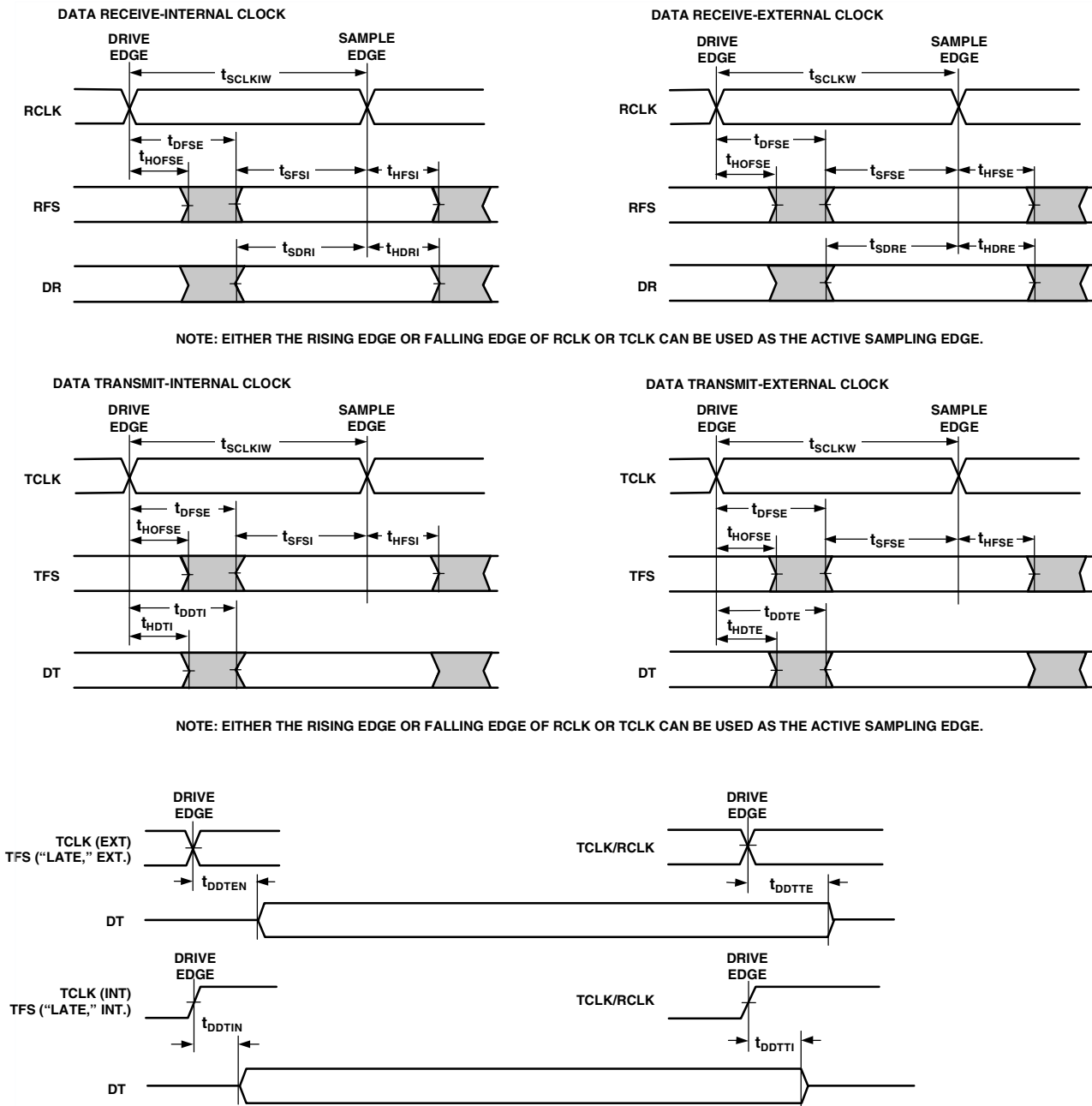

Figure 12. Serial Port

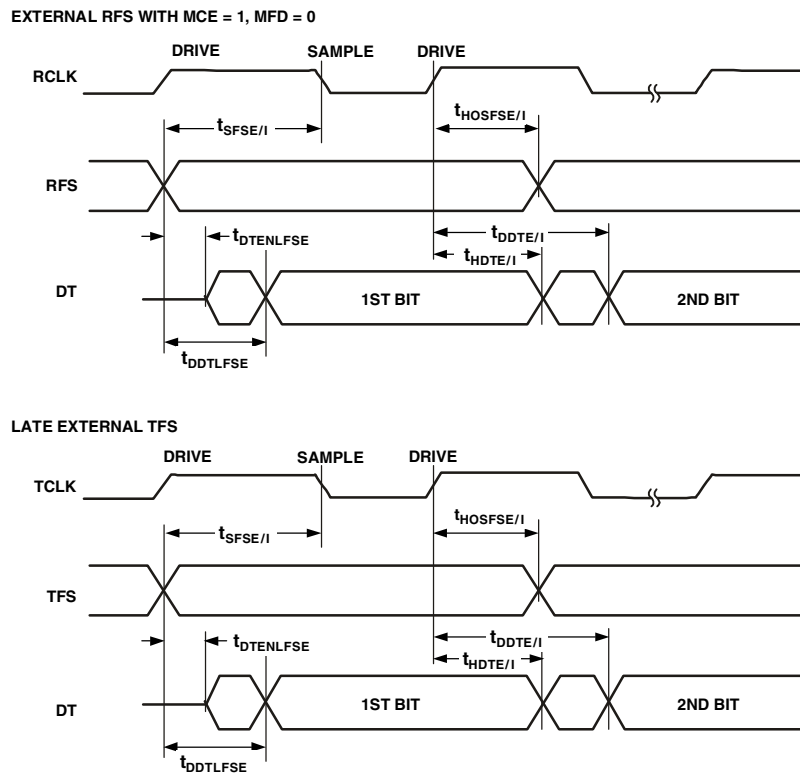

Figure 13. Serial Port—External Late Frame Sync (Frame Sync Setup > $0.5t_{SCLK}$)

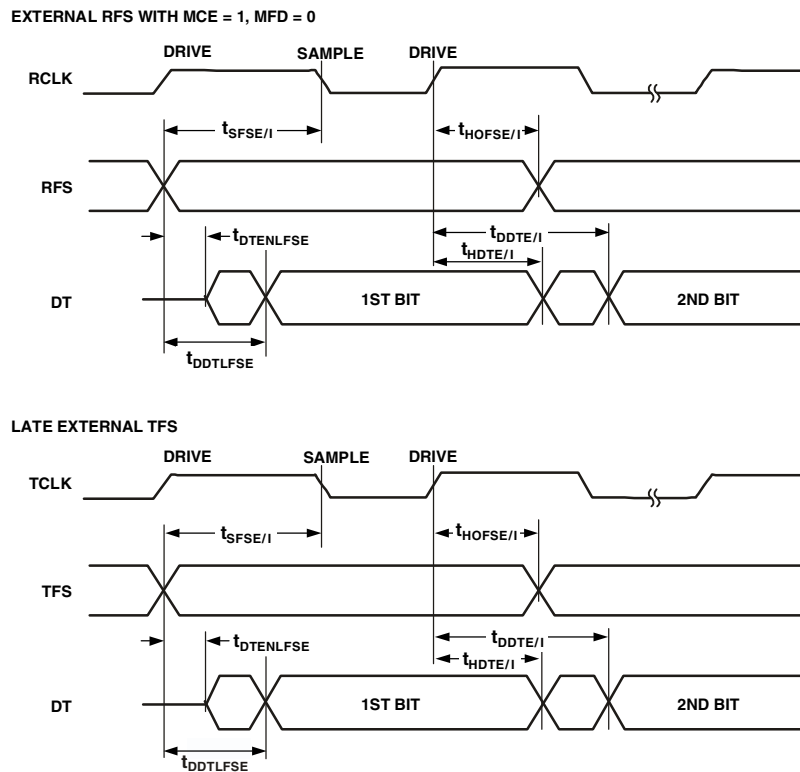

Figure 14. Serial Port—External Late Frame Sync (Frame Sync Setup < $0.5t_{HCLK}$)

ADSP-21991

Serial Peripheral Interface Port—Master Timing

Table 12 and Figure 15 describe SPI port master operations.

Table 12. Serial Peripheral Interface (SPI) Port—Master Timing

Parameter	Min	Max	Unit
<i>Timing Requirements</i>			
t_{SSPID} Data Input Valid to SCLK Edge (Data Input Setup)	8		ns
t_{HSPID} SCLK Sampling Edge to Data Input Invalid (Data In Hold)	1		ns
<i>Switching Characteristics</i>			
t_{SDSCIM} SPISEL Low to First SCLK Edge	$2t_{HCLK}-3$		ns
t_{SPICHM} Serial Clock High Period	$2t_{HCLK}-3$		ns
t_{SPICLM} Serial Clock Low Period	$2t_{HCLK}-3$		ns
t_{SPICLK} Serial Clock Period	$4t_{HCLK}-1$		ns
t_{HDSM} Last SCLK Edge to SPISEL High	$2t_{HCLK}-3$		ns
t_{SPITDM} Sequential Transfer Delay	$2t_{HCLK}-2$		ns
t_{DDSPID} SCLK Edge to Data Output Valid (Data Out Delay)	0	6	ns
t_{HDSPID} SCLK Edge to Data Output Invalid (Data Out Hold)	0	5	ns

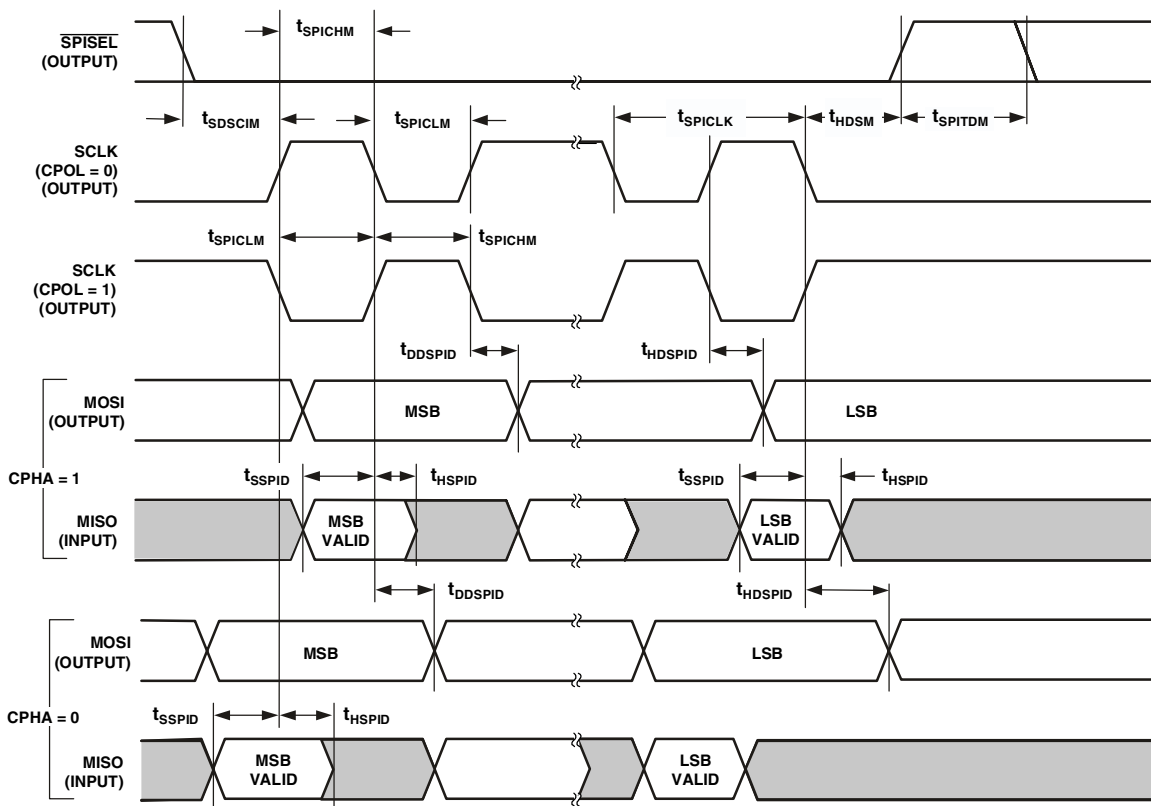

Figure 15. Serial Peripheral Interface (SPI) Port—Master Timing

Serial Peripheral Interface Port—Slave Timing

Table 13 and Figure 16 describe SPI port slave operations.

Table 13. Serial Peripheral Interface (SPI) Port—Slave Timing

Parameter		Min	Max	Unit
<i>Timing Requirements</i>				
t_{SPICHS}	Serial Clock High Period	$2t_{HCLK}$		ns
t_{SPICLS}	Serial Clock Low Period	$2t_{HCLK}$		ns
t_{SPICLK}	Serial Clock Period	$4t_{HCLK}$		ns
t_{HDS}	Last SPICLK Edge to \overline{SPISS} Not Asserted	$2t_{HCLK}$		ns
t_{SPITDS}	Sequential Transfer Delay	$2t_{HCLK} + 4$		ns
t_{SDSCI}	\overline{SPISS} Assertion to First SPICLK Edge	$2t_{HCLK}$		ns
t_{SSPID}	Data Input Valid to SCLK Edge (Data Input Setup)	1.6		ns
t_{HSPID}	SCLK Sampling Edge to Data Input Invalid (Data In Hold)	2.4		ns
<i>Switching Characteristics</i>				
t_{DSOE}	\overline{SPISS} Assertion to Data Out Active	0	8	ns
t_{DSDHI}	\overline{SPISS} Deassertion to Data High Impedance	0	10	ns
t_{DDSPID}	SCLK Edge to Data Out Valid (Data Out Delay)	0	10	ns
t_{HDSPID}	SCLK Edge to Data Out Invalid (Data Out Hold)	0	10	ns

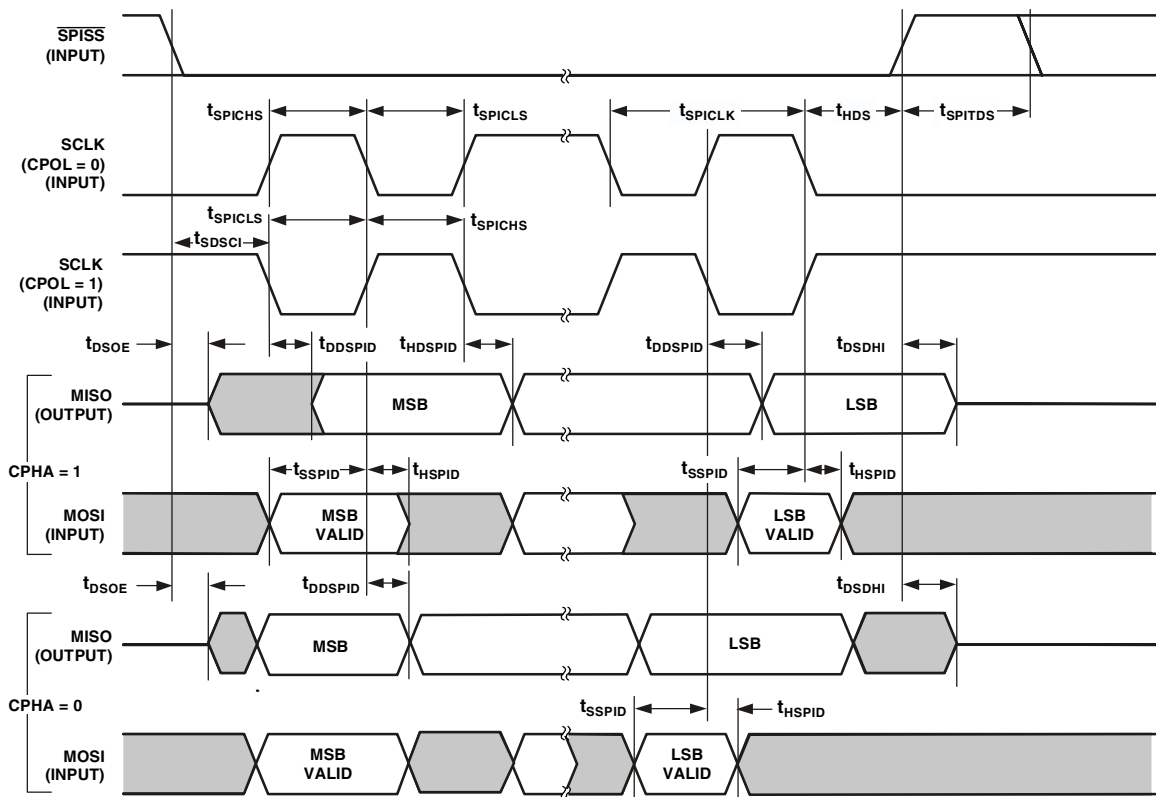

Figure 16. Serial Peripheral Interface (SPI) Port—Slave Timing

ADSP-21991

JTAG Test And Emulation Port Timing

Table 14 and Figure 17 describe JTAG port operations.

Table 14. JTAG Port Timing

Parameter	Min	Max	Unit
<i>Timing Requirements</i>			
t_{TCK} TCK Period	20		ns
t_{STAP} TDI, TMS Setup Before TCK High		4	ns
t_{HTAP} TDI, TMS Hold After TCK High		4	ns
t_{SSYS} System Inputs Setup Before TCK Low ¹		4	ns
t_{HSYS} System Inputs Hold After TCK Low ¹		5	ns
t_{TRSTW} \overline{TRST} Pulsewidth ²	$4t_{TCK}$		ns
<i>Switching Characteristics</i>			
t_{DTDO} TDO Delay from TCK Low		8	ns
t_{DSYS} System Outputs Delay After TCK Low ³	0	22	ns

¹System Outputs = DATA15-0, ADDR21-0, $\overline{MS3-0}$, \overline{RD} , \overline{WR} , ACK, CLKOUT, \overline{BG} , PF15-0, DT, TCLK, RCLK, TFS, RFS, \overline{BMS} .

²50 MHz maximum.

³System Inputs = DATA15-0, ADDR21-0, \overline{RD} , \overline{WR} , ACK, \overline{BR} , \overline{BG} , PF15-0, \overline{DR} , TCLK, RCLK, TFS, RFS, CLKOUT, \overline{RESET} .

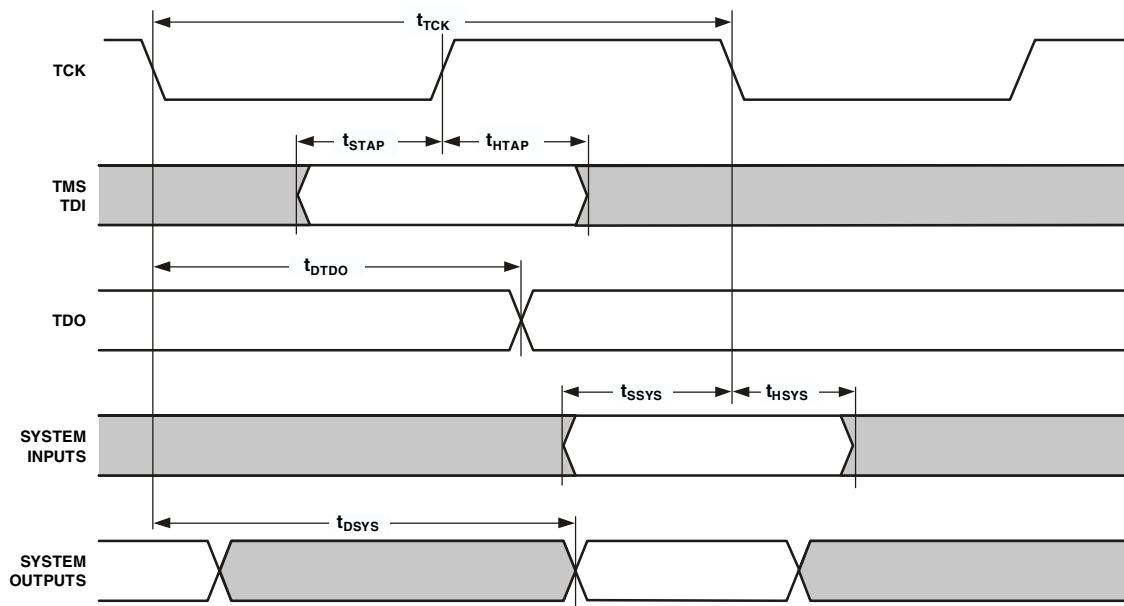

Figure 17. JTAG Port Timing

Power Dissipation

Total power dissipation has two components, one due to internal circuitry and one due to the switching of external output drivers. Internal power dissipation is dependent on the instruction execution sequence and the data operands involved.

The external component of total power dissipation is caused by the switching of output pins. Its magnitude depends on:

- Number of output pins that switch during each cycle (O)
- The maximum frequency at which they can switch (f)
- Their load capacitance (C)
- Their voltage swing (V_{DD})

and is calculated by the formula below.

$$P_{EXT} = O \times C \times V_{DD}^2 \times f$$

Table 15. P_{EXT} Calculation Example

Pin Type	No. of Pins	% Switching	× C	× f	× V _{DD} ²	= P _{EXT}
Address	15	50	10 pF	20 MHz	10.9 V	= 0.01635 W
\overline{MSx}	1	0	10 pF	20 MHz	10.9 V	= 0.0 W
\overline{WR}	1		10 pF	40 MHz	10.9 V	= 0.00436 W
Data	16	50	10 pF	20 MHz	10.9 V	= 0.01744 W
CLKOUT	1		10 pF	80 MHz	10.9 V	= 0.00872 W
						= 0.04687 W

A typical power consumption can now be calculated for these conditions by adding a typical internal power dissipation with the following formula.

$$P_{TOTAL} = P_{EXT} + P_{INT}$$

Where:

- P_{EXT} is from [Table 15](#)
- P_{INT} is I_{DDINT} × 2.5 V, using the calculation I_{DDINT} listed in [Power Dissipation](#).

Note that the conditions causing a worst-case P_{EXT} are different from those causing a worst-case P_{INT}. Maximum P_{INT} cannot occur while 100% of the output pins are switching from all ones to all zeros. Note also that it is not common for an application to have 100% or even 50% of the outputs switching simultaneously.

Test Conditions

The DSP is tested for output enable, disable, and hold time.

Output Disable Time

Output pins are considered to be disabled when they stop driving, go into a high impedance state, and start to decay from their output high or low voltage. The time for the voltage on the bus to decay by ΔV is dependent on the capacitive load, C_L and the load current, I_L. This decay time can be approximated by the following equation.

$$t_{DECAY} = \frac{C_L \Delta V}{I_L}$$

The load capacitance includes the package capacitance (C_{IN} of the processor). The switching frequency includes driving the load high and then back low. Address and data pins can drive high and low at a maximum rate of 1/(2t_{CK}). The write strobe can switch every cycle at a frequency of 1/t_{CK}. Select pins switch at 1/(2t_{CK}), but selects can switch on each cycle. For example, estimate P_{EXT} with the following assumptions:

- A system with one bank of external data memory—asynchronous RAM (16-bit)
- One 64K×16 RAM chip is used with a load of 10 pF
- Maximum peripheral speed CCLK = 80 MHz, HCLK = 80 MHz
- External data memory writes occur every other cycle, a rate of 1/(4t_{HCLK}), with 50% of the pins switching
- The bus cycle time is 80 MHz (t_{HCLK} = 12.5 ns)

The P_{EXT} equation is calculated for each class of pins that can drive as shown in [Table 15](#).

The output disable time t_{DIS} is the difference between t_{MEASURED} and t_{DECAY} as shown in [Figure 18](#). The time t_{MEASURED} is the interval from when the reference signal switches to when the output voltage decays ΔV from the measured output high or output low voltage. The t_{DECAY} is calculated with test loads C_L and I_L, and with ΔV equal to 0.5 V.

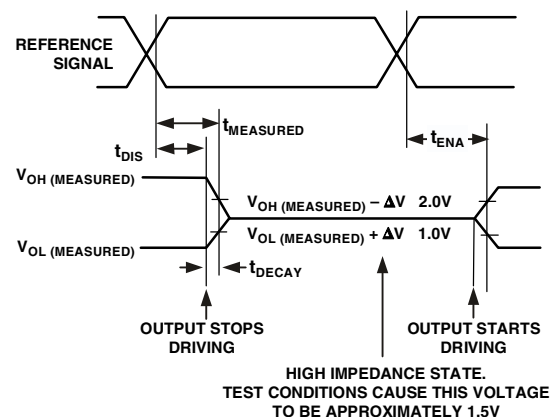

Figure 18. Output Enable/Disable

ADSP-21991

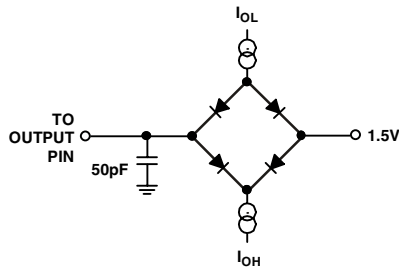

Figure 19. Equivalent Device Loading for AC Measurements (Includes All Fixtures)



Figure 20. Voltage Reference Levels for AC Measurements (Except Output Enable/Disable)

Output Enable Time

Output pins are considered to be enabled when they have made a transition from a high impedance state to when they start driving. The output enable time t_{ENA} is the interval from when a reference signal reaches a high or low voltage level to when the output has reached a specified high or low trip point, as shown in the Output Enable/Disable diagram (Figure 18). If multiple pins (such as the data bus) are enabled, the measurement value is that of the first pin to start driving.

Example System Hold Time Calculation

To determine the data output hold time in a particular system, first calculate t_{DECAY} using the equation at Output Disable Time on Page 35. Choose ΔV to be the difference between the output voltage of the ADSP-21991 and the input threshold for the device requiring the hold time. A typical ΔV will be 0.4 V. C_L is the total bus capacitance (per data line), and I_L is the total leakage or three-state current (per data line). The hold time will be t_{DECAY} plus the minimum disable time (i.e., t_{DATRWH} for the write cycle).

Pin Configurations

Table 16 identifies the signal for each Mini-BGA ball number.

Table 17 identifies the Mini-BGA ball number for each signal name.

Table 18 identifies the signal for each LQFP lead.

Table 19 identifies the LQFP lead for each signal name.

Table 4 describes each signal.

Table 16. 196-Ball Mini-BGA Signal by Ball Number

Ball No.	Signal	Ball No.	Signal	Ball No.	Signal	Ball No.	Signal
A1	nc	D8	AVSS	H1	A10	L8	VDDINT
A2	DR	D9	PF3/SPISEL3	H2	A11	L9	VDDEXT
A3	DT	D10	AUXTRIP	H3	MS3	L10	VDDEXT
A4	RFS	D11	VDDEXT	H4	GND	L11	GND
A5	VIN4	D12	AUX1	H5	nc	L12	BMODE2
A6	BSHAN	D13	AUX0	H6	nc	L13	BMODE1
A7	VIN0	D14	PF15	H7	nc	L14	CLKIN
A8	VIN1	E1	A16	H8	nc	M1	A2
A9	VIN3	E2	A17	H9	nc	M2	A3
A10	PF0/SPISS	E3	WR	H10	nc	M3	MS2
A11	PF4/SPISEL4	E4	GND	H11	VDDEXT	M4	GND
A12	PF6/SPISEL6	E5	VDDEXT	H12	TMR0	M5	VDDEXT
A13	PF7/SPISEL7	E6	nc	H13	POR	M6	GND
A14	nc	E7	nc	H14	RESET	M7	VDDEXT
B1	SCK	E8	nc	J1	A8	M8	nc
B2	RCLK	E9	nc	J2	A9	M9	CL
B3	TCLK	E10	nc	J3	BMS	M10	AL
B4	TFS	E11	GND	J4	VDDEXT	M11	PWMPOL
B5	VIN6	E12	EIA	J5	nc	M12	PWMTRIP
B6	ASHAN	E13	EIB	J6	nc	M13	BYPASS
B7	VIN2	E14	EIS	J7	nc	M14	BMODE0
B8	SENSE	F1	A14	J8	nc	N1	A0
B9	CAPB	F2	A15	J9	nc	N2	A1
B10	PF1/SPISEL1	F3	BG	J10	nc	N3	D13
B11	PF5/SPISEL5	F4	GND	J11	GND	N4	D11
B12	PF8	F5	nc	J12	TMS	N5	D9
B13	PF9	F6	nc	J13	TCK	N6	D7
B14	PF13	F7	nc	J14	TDI	N7	D5
C1	BR	F8	nc	K1	A6	N8	D3
C2	RD	F9	nc	K2	A7	N9	D1
C3	MISO	F10	nc	K3	MS0	N10	CH
C4	MOSI	F11	VDDINT	K4	GND	N11	AH
C5	VIN7	F12	EIZ	K5	GND	N12	nc
C6	VIN5	F13	TMR2	K6	GND	N13	PWMSYNC
C7	CAPT	F14	XTAL	K7	GND	N14	PWMSR
C8	VREF	G1	A12	K8	GND	P1	nc
C9	CML	G2	A13	K9	GND	P2	D15
C10	PF2/SPISEL2	G3	BGH	K10	GND	P3	D14
C11	PF10	G4	VDDINT	K11	VDDINT	P4	D12
C12	PF11	G5	nc	K12	EMU	P5	D10
C13	PF12	G6	nc	K13	TRST	P6	D8
C14	PF14	G7	nc	K14	TDO	P7	D6
D1	A18	G8	nc	L1	A4	P8	D4
D2	A19	G9	nc	L2	A5	P9	D2
D3	IOMS	G10	nc	L3	MS1	P10	D0
D4	ACK	G11	GND	L4	VDDEXT	P11	BL
D5	AVDD	G12	TMR1	L5	VDDINT	P12	BH
D6	AVDD	G13	CONVST	L6	VDDEXT	P13	nc
D7	AVSS	G14	CLKOUT	L7	VDDINT	P14	nc

ADSP-21991

Table 17. 196-Ball Mini-BGA Ball Number by Signal

Signal	Ball No.	Signal	Ball No.	Signal	Ball No.	Signal	Ball No.
A0	N1	CONVST	G13	nc	E6	PF15	D14
A1	N2	D0	P10	nc	E7	$\overline{\text{POR}}$	H13
A2	M1	D1	N9	nc	E8	PWMPOL	M11
A3	M2	D2	P9	nc	E9	PWMSYNC	N13
A4	L1	D3	N8	nc	E10	$\overline{\text{PWMSR}}$	N14
A5	L2	D4	P8	nc	F5	$\overline{\text{PWMTRIP}}$	M12
A6	K1	D5	N7	nc	F6	RCLK	B2
A7	K2	D6	P7	nc	F7	$\overline{\text{RD}}$	C2
A8	J1	D7	N6	nc	F8	$\overline{\text{RESET}}$	H14
A9	J2	D8	P6	nc	F9	RFS	A4
A10	H1	D9	N5	nc	F10	SCK	B1
A11	H2	D10	P5	nc	G5	SENSE	B8
A12	G1	D11	N4	nc	G6	TCK	J13
A13	G2	D12	P4	nc	G7	TCLK	B3
A14	F1	D13	N3	nc	G8	TDI	J14
A15	F2	D14	P3	nc	G9	TDO	K14
A16	E1	D15	P2	nc	G10	TFS	B4
A17	E2	DR	A2	nc	H5	TMR0	H12
A18	D1	DT	A3	nc	H6	TMR1	G12
A19	D2	EIA	E12	nc	H7	TMR2	F13
ACK	D4	EIB	E13	nc	H8	TMS	J12
AH	N11	EIS	E14	nc	H9	$\overline{\text{TRST}}$	K13
AL	M10	EIZ	F12	nc	H10	VDDEXT	D11
ASHAN	B6	$\overline{\text{EMU}}$	K12	nc	J5	VDDEXT	E5
$\overline{\text{AUXTRIP}}$	D10	GND	E4	nc	J6	VDDEXT	H11
AUX1	D12	GND	E11	nc	J7	VDDEXT	J4
AUX0	D13	GND	F4	nc	J8	VDDEXT	L4
AVDD	D5	GND	G11	nc	J9	VDDEXT	L6
AVDD	D6	GND	H4	nc	J10	VDDEXT	L9
AVSS	D7	GND	J11	nc	M8	VDDEXT	L10
AVSS	D8	GND	K4	nc	N12	VDDEXT	M5
$\overline{\text{BG}}$	F3	GND	K5	nc	P1	VDDEXT	M7
$\overline{\text{BGH}}$	G3	GND	K6	nc	P13	VDDINT	G4
BL	P11	GND	K7	nc	P14	VDDINT	L5
BH	P12	GND	K8	nc	PF0/ $\overline{\text{SPISS}}$	VDDINT	L7
BMODE0	M14	GND	K9	nc	PF1/SPISEL1	VDDINT	L8
BMODE1	L13	GND	K10	nc	PF2/SPISEL2	VDDINT	K11
BMODE2	L12	GND	L11	nc	PF3/SPISEL3	VDDINT	F11
$\overline{\text{BMS}}$	J3	GND	M4	nc	PF4/SPISEL4	VIN0	A7
$\overline{\text{BR}}$	C1	GND	M6	nc	PF5/SPISEL5	VIN1	A8
BSHAN	A6	$\overline{\text{IOMS}}$	D3	nc	PF6/SPISEL6	VIN2	B7
BYPASS	M13	MISO	C3	nc	PF7/SPISEL7	VIN3	A9
CAPB	B9	MOSI	C4	nc	PF8	VIN4	A5
CAPT	C7	$\overline{\text{MS0}}$	K3	nc	PF9	VIN5	C6
CH	N10	$\overline{\text{MS1}}$	L3	nc	PF10	VIN6	B5
CL	M9	$\overline{\text{MS2}}$	M3	nc	PF11	VIN7	C5
CLKIN	L14	$\overline{\text{MS3}}$	H3	nc	PF12	VREF	C8
CLKOUT	G14	nc	A1	nc	PF13	$\overline{\text{WR}}$	E3
CML	C9	nc	A14	nc	PF14	XTAL	F14

Table 18. 176-Lead LQFP Signal by Lead Number

Lead No.	Signal	Lead No.	Signal	Lead No.	Signal	Lead No.	Signal
1	nc	45	VDDEXT	89	nc	133	VDDEXT
2	nc	46	A4	90	nc	134	PF11
3	VDDEXT	47	A3	91	VDDEXT	135	PF10
4	RCLK	48	A2	92	BYPASS	136	PF9
5	SCK	49	A1	93	BMODE0	137	PF8
6	MISO	50	A0	94	BMODE1	138	PF7/SPISEL7
7	MOSI	51	D15	95	BMODE2	139	PF6/SPISEL6
8	\overline{RD}	52	D14	96	nc	140	PF5/SPISEL5
9	\overline{WR}	53	D13	97	GND	141	PF4/SPISEL4
10	ACK	54	D12	98	VDDINT	142	GND
11	\overline{BR}	55	D11	99	\overline{EMU}	143	VDDEXT
12	\overline{BG}	56	GND	100	\overline{TRST}	144	PF3/SPISEL3
13	\overline{BGH}	57	VDDEXT	101	TDO	145	PF2/SPISEL2
14	\overline{IOMS}	58	GND	102	TDI	146	PF1/SPISEL1
15	\overline{BMS}	59	VDDINT	103	TMS	147	PF0/ \overline{SPISS}
16	$\overline{MS3}$	60	D10	104	TCK	148	GND
17	GND	61	D9	105	\overline{POR}	149	VDDINT
18	VDDEXT	62	D8	106	\overline{RESET}	150	AVSS
19	$\overline{MS2}$	63	D7	107	CLKIN	151	AVDD
20	$\overline{MS1}$	64	D6	108	XTAL	152	nc
21	$\overline{MS0}$	65	D5	109	CLKOUT	153	VREF
22	GND	66	GND	110	CONVST	154	CML
23	VDDINT	67	VDDINT	111	TMR0	155	CAPT
24	A19	68	D4	112	GND	156	CAPB
25	A18	69	D3	113	VDDEXT	157	SENSE
26	A17	70	D2	114	TMR1	158	VIN3
27	A16	71	D1	115	TMR2	159	VIN2
28	A15	72	D0	116	EIS	160	VIN1
29	A14	73	nc	117	GND	161	VIN0
30	A13	74	GND	118	VDDINT	162	ASHAN
31	GND	75	VDDEXT	119	EIZ	163	BSHAN
32	VDDEXT	76	CL	120	EIB	164	VIN4
33	A12	77	CH	121	EIA	165	VIN5
34	A11	78	BL	122	$\overline{AUXTRIP}$	166	VIN6
35	A10	79	BH	123	AUX1	167	VIN7
36	A9	80	AL	124	AUX0	168	AVSS
37	A8	81	AH	125	PF15	169	AVDD
38	A7	82	nc	126	PF14	170	DT
39	A6	83	nc	127	PF13	171	DR
40	A5	84	PWMSYNC	128	PF12	172	RFS
41	GND	85	PWMPOL	129	GND	173	TFS
42	nc	86	\overline{PWMSR}	130	nc	174	TCLK
43	nc	87	$\overline{PWMTRIP}$	131	nc	175	GND
44	nc	88	GND	132	nc	176	nc

ADSP-21991

Table 19. 176-Lead LQFP Lead Number by Signal

Signal	Lead No.	Signal	Lead No.	Signal	Lead No.	Signal	Lead No.
A0	50	CAPB	156	EIS	116	PWMTRIP	87
A1	49	CAPT	155	EIZ	119	RCLK	4
A10	35	CH	77	EMU	99	RD	8
A11	34	CL	76	IOMS	14	RESET	106
A12	33	CLKIN	107	MISO	6	RFS	172
A13	30	CLKOUT	109	MOSI	7	SCK	5
A14	29	CML	154	MS0	21	SENSE	157
A15	28	CONVST	110	MS1	20	TCK	104
A16	27	D0	72	MS2	19	TCLK	174
A17	26	D1	71	MS3	16	TDI	102
A18	25	D10	60	nc	1	TDO	101
A19	24	D11	55	nc	2	TFS	173
A2	48	D12	54	nc	42	TMR0	111
A3	47	D13	53	nc	43	TMR1	114
A4	46	D14	52	nc	44	TMR2	115
A5	40	D15	51	nc	83	TMS	103
A6	39	D2	70	nc	89	TRST	100
A7	38	D3	69	nc	90	VDDEXT	3
A8	37	D4	68	nc	96	VDDEXT	18
A9	36	D5	65	nc	130	VDDEXT	32
ACK	10	D6	64	nc	131	VDDEXT	45
AH	81	D7	63	nc	132	VDDEXT	57
AL	80	D8	62	nc	152	VDDEXT	75
ASHAN	162	D9	61	nc	176	VDDEXT	91
AUX0	124	GND	17	PF0/SPISS	147	VDDEXT	113
AUX1	123	GND	22	PF1/SPISEL1	146	VDDEXT	133
AUXTRIP	122	GND	31	PF10	135	VDDEXT	143
AVDD	151	GND	41	PF11	134	VDDINT	23
AVDD	169	GND	56	PF12	128	VDDINT	59
AVSS	150	GND	58	PF13	127	VDDINT	67
AVSS	168	GND	66	PF14	126	VDDINT	98
BG	12	GND	74	PF15	125	VDDINT	118
BGH	13	GND	88	PF2/SPISEL2	145	VDDINT	149
BH	79	GND	97	PF3/SPISEL3	144	VIN0	161
BL	78	GND	112	PF4/SPISEL4	141	VIN1	160
BMODE0	93	GND	117	PF5/SPISEL5	140	VIN2	159
BMODE1	94	GND	129	PF6/SPISEL6	139	VIN3	158
BMODE2	95	GND	142	PF7/SPISEL7	138	VIN4	164
BMS	15	GND	148	PF8	137	VIN5	165
BR	11	GND	175	PF9	136	VIN6	166
BSHAN	163	DR	171	POR	105	VIN7	167
BYPASS	92	DT	170	PWMPOL	85	VREF	153
nc	73	EIA	121	PWMSR	86	WR	9
nc	82	EIB	120	PWMSYNC	84	XTAL	108

OUTLINE DIMENSIONS

Dimensions shown in millimeters.

196-Ball Mini-BGA (BC-196-2)

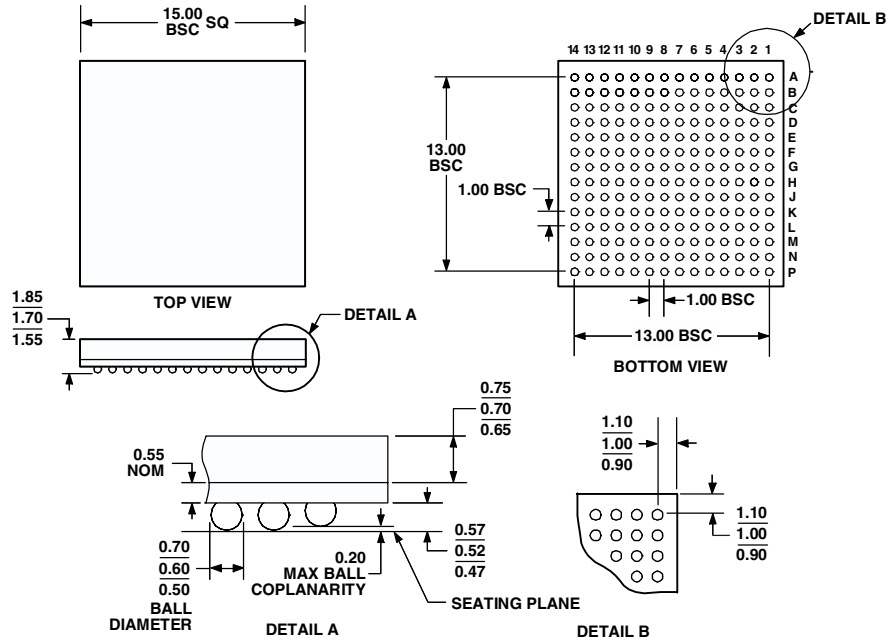

NOTES:

1. THE ACTUAL POSITION OF THE BALL GRID IS WITHIN 0.25 OF ITS IDEAL POSITION RELATIVE TO THE PACKAGE EDGES.
2. THE ACTUAL POSITION OF EACH BALL IS WITHIN 0.10 OF ITS IDEAL POSITION RELATIVE TO THE BALL GRID.
3. DIMENSIONS COMPLY WITH JEDEC STANDARD MO-192 VARIATION AAE-1 WITH THE EXCEPTION OF MAXIMUM HEIGHT.
4. CENTER DIMENSIONS ARE NOMINAL.

176-Lead LQFP (ST-176-1)

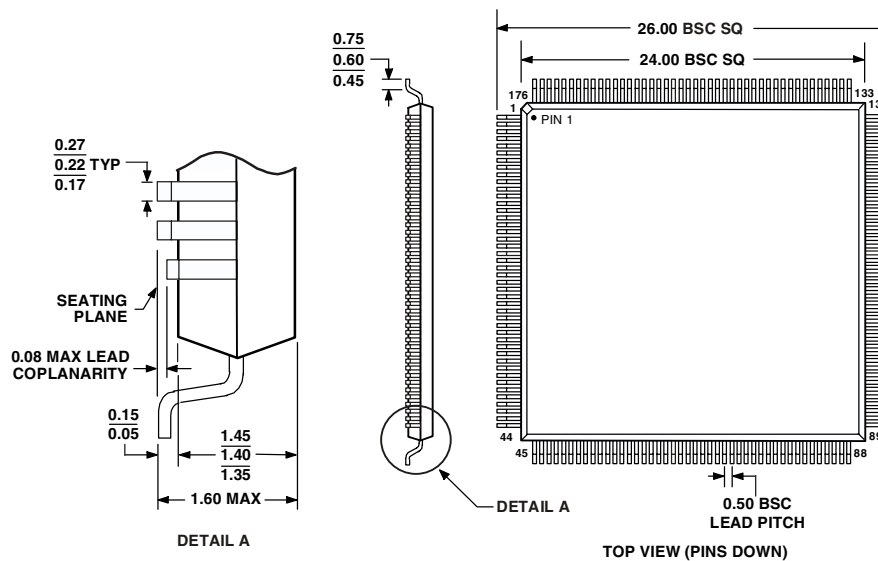

NOTES:

1. DIMENSIONS IN MILLIMETERS.
2. ACTUAL POSITION OF EACH LEAD IS WITHIN 0.08 OF ITS IDEAL POSITION, WHEN MEASURED IN THE LATERAL DIRECTION.
3. CENTER DIMENSIONS ARE NOMINAL.
4. DIMENSIONS COMPLY WITH JEDEC STANDARD MS-026-BGA.

ADSP-21991

ORDERING GUIDE

Part Number	Ambient Temperature Range	Instruction Rate	Operating Voltage	Package
ADSP-21991BBC	-40°C to +85°C	150 MHz	2.5 Int./3.3 Ext. V	196-Ball Mini-BGA
ADSP-21991BST	-40°C to +85°C	160 MHz	2.5 Int./3.3 Ext. V	176-Lead LQFP

