

## QUAD D-TYPE FLIP FLOP WITH CLEAR

- HIGH SPEED :  
 $t_{PD} = 16 \text{ ns (TYP.) at } V_{CC} = 6V$
- LOW POWER DISSIPATION:  
 $I_{CC} = 4\mu\text{A (MAX.) at } T_A = 25^\circ\text{C}$
- HIGH NOISE IMMUNITY:  
 $V_{NIH} = V_{NIL} = 28 \% V_{CC} \text{ (MIN.)}$
- SYMMETRICAL OUTPUT IMPEDANCE:  
 $|I_{OH}| = I_{OL} = 4\text{mA (MIN)}$
- BALANCED PROPAGATION DELAYS:  
 $t_{PLH} \approx t_{PHL}$
- WIDE OPERATING VOLTAGE RANGE:  
 $V_{CC} \text{ (OPR)} = 2V \text{ to } 6V$
- PIN AND FUNCTION COMPATIBLE WITH  
 74 SERIES 175

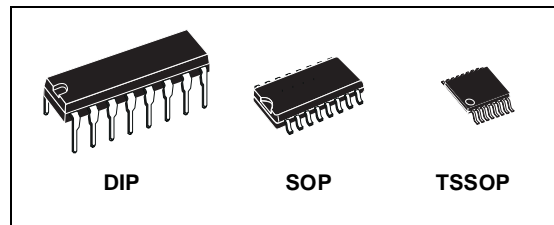

### ORDER CODES

PACKAGE	TUBE	T & R
DIP	M74HC175B1R	
SOP	M74HC175M1R	M74HC175RM13TR
TSSOP		M74HC175TTR

### DESCRIPTION

The M74HC175 is an high speed CMOS HEX D-TYPE FLIP FLOP WITH CLEAR fabricated with silicon gate C<sup>2</sup>MOS technology.

These four flip-flops are controlled by a clock input (CLOCK) and a clear input (CLEAR). The information data applied to the D inputs (1D to 4D) are transferred to the outputs (1Q to 4Q and 1Q to 4Q)

4Q) on the positive-going edge of the clock pulse. The reset function is accomplished when the CLEAR input is low and all Q outputs are low regardless of other input conditions.

All inputs are equipped with protection circuits against static discharge and transient excess voltage.

### PIN CONNECTION AND IEC LOGIC SYMBOLS

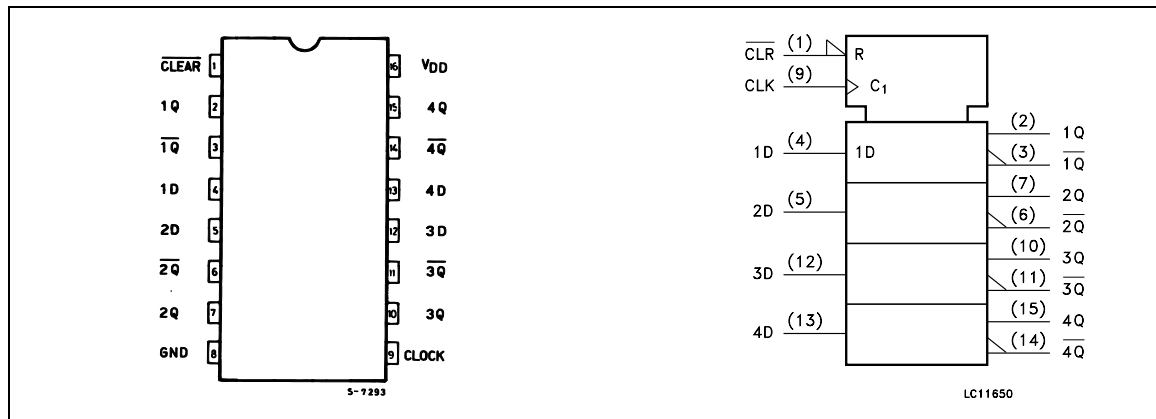

# M74HC175

## INPUT AND OUTPUT EQUIVALENT CIRCUIT

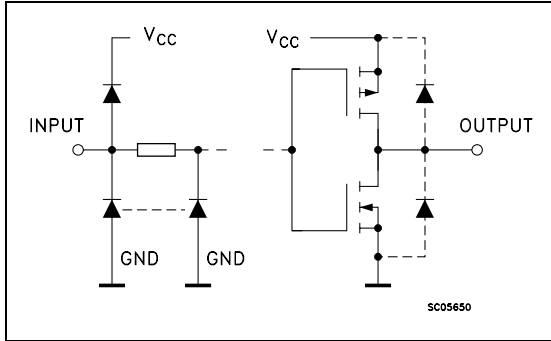

## PIN DESCRIPTION

PIN No	SYMBOL	NAME AND FUNCTION
1	$\overline{\text{CLEAR}}$	Asynchronous Master Reset (Active Low)
2, 7, 10, 15	1Q to 4Q	Flip-Flop Outputs
3, 6, 11, 14	$1\overline{\text{Q}}$ to $4\overline{\text{Q}}$	Complementary Flip-Flop Outputs
4, 5, 12, 13	1D to 4D	Data Inputs
9	CLOCK	Clock Input (LOW to HIGH, edge triggered)
8	GND	Ground (0V)
16	Vcc	Positive Supply Voltage

## TRUTH TABLE

INPUTS			OUTPUTS		FUNCTION
$\overline{\text{CLEAR}}$	D	CLOCK	Q	$\overline{\text{Q}}$	
L	X	X	L	H	
H	L		L	H	
H	H		H	L	
H	X		Qn	$\overline{\text{Q}}_n$	NO CHANGE

X : Don't Care

## LOGIC DIAGRAM

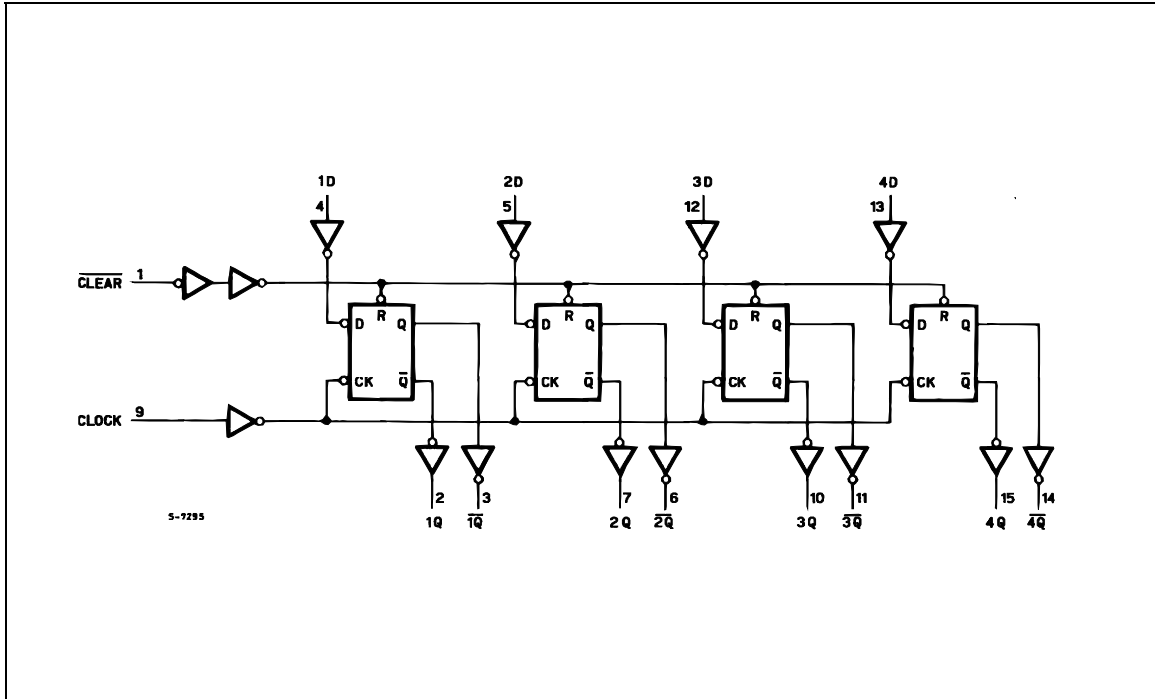

This logic diagram has not be used to estimate propagation delays

**ABSOLUTE MAXIMUM RATINGS**

Symbol	Parameter	Value	Unit
$V_{CC}$	Supply Voltage	-0.5 to +7	V
$V_I$	DC Input Voltage	-0.5 to $V_{CC} + 0.5$	V
$V_O$	DC Output Voltage	-0.5 to $V_{CC} + 0.5$	V
$I_{IK}$	DC Input Diode Current	$\pm 20$	mA
$I_{OK}$	DC Output Diode Current	$\pm 20$	mA
$I_O$	DC Output Current	$\pm 25$	mA
$I_{CC}$ or $I_{GND}$	DC $V_{CC}$ or Ground Current	$\pm 50$	mA
$P_D$	Power Dissipation	500(*)	mW
$T_{stg}$	Storage Temperature	-65 to +150	°C
$T_L$	Lead Temperature (10 sec)	300	°C

Absolute Maximum Ratings are those values beyond which damage to the device may occur. Functional operation under these conditions is not implied

(\*) 500mW at 65 °C; derate to 300mW by 10mW/°C from 65°C to 85°C

**RECOMMENDED OPERATING CONDITIONS**

Symbol	Parameter	Value	Unit	
$V_{CC}$	Supply Voltage	2 to 6	V	
$V_I$	Input Voltage	0 to $V_{CC}$	V	
$V_O$	Output Voltage	0 to $V_{CC}$	V	
$T_{op}$	Operating Temperature	-55 to 125	°C	
$t_r, t_f$	Input Rise and Fall Time	$V_{CC} = 2.0V$	0 to 1000	ns
		$V_{CC} = 4.5V$	0 to 500	ns
		$V_{CC} = 6.0V$	0 to 400	ns

## DC SPECIFICATIONS

Symbol	Parameter	Test Condition		Value						Unit	
		V <sub>CC</sub> (V)		T <sub>A</sub> = 25°C			-40 to 85°C		-55 to 125°C		
				Min.	Typ.	Max.	Min.	Max.	Min.		Max.
V <sub>IH</sub>	High Level Input Voltage	2.0		1.5			1.5		1.5		V
		4.5		3.15			3.15		3.15		
		6.0		4.2			4.2		4.2		
V <sub>IL</sub>	Low Level Input Voltage	2.0				0.5		0.5		0.5	V
		4.5				1.35		1.35		1.35	
		6.0				1.8		1.8		1.8	
V <sub>OH</sub>	High Level Output Voltage	2.0	I <sub>O</sub> =-20 μA	1.9	2.0		1.9		1.9		V
		4.5	I <sub>O</sub> =-20 μA	4.4	4.5		4.4		4.4		
		6.0	I <sub>O</sub> =-20 μA	5.9	6.0		5.9		5.9		
		4.5	I <sub>O</sub> =-4.0 mA	4.18	4.31		4.13		4.10		
		6.0	I <sub>O</sub> =-5.2 mA	5.68	5.8		5.63		5.60		
V <sub>OL</sub>	Low Level Output Voltage	2.0	I <sub>O</sub> =20 μA		0.0	0.1		0.1		0.1	V
		4.5	I <sub>O</sub> =20 μA		0.0	0.1		0.1		0.1	
		6.0	I <sub>O</sub> =20 μA		0.0	0.1		0.1		0.1	
		4.5	I <sub>O</sub> =4.0 mA		0.17	0.26		0.33		0.40	
		6.0	I <sub>O</sub> =5.2 mA		0.18	0.26		0.33		0.40	
I <sub>I</sub>	Input Leakage Current	6.0	V <sub>I</sub> = V <sub>CC</sub> or GND			± 0.1		± 1		± 1	μA
I <sub>CC</sub>	Quiescent Supply Current	6.0	V <sub>I</sub> = V <sub>CC</sub> or GND			4		40		80	μA

AC ELECTRICAL CHARACTERISTICS ( $C_L = 50$  pF, Input  $t_r = t_f = 6$  ns)

Symbol	Parameter	Test Condition		Value						Unit		
		$V_{CC}$ (V)		$T_A = 25^\circ\text{C}$			$-40$ to $85^\circ\text{C}$		$-55$ to $125^\circ\text{C}$			
				Min.	Typ.	Max.	Min.	Max.	Min.		Max.	
$t_{TLH}$ $t_{THL}$	Output Transition Time	2.0			30	75		95		110	ns	
		4.5			8	15		19		22		
		6.0			7	13		16		19		
$t_{PLH}$ $t_{PHL}$	Propagation Delay Time (CLOCK - Q, $\bar{Q}$ )	2.0			60	150		190		225	ns	
		4.5			19	30		38		45		
		6.0			16	26		32		38		
$t_{PLH}$ $t_{PHL}$	Propagation Delay Time ( $\overline{\text{CLEAR}}$ - Q, $\bar{Q}$ )	2.0			50	125		155		190	ns	
		4.5			16	25		31		38		
		6.0			14	21		26		32		
$f_{MAX}$	Maximum Clock Frequency	2.0			6.2	13		5		4.2	MHz	
		4.5			31	52		25		21		
		6.0			37	61		30		25		
$t_{W(H)}$ $t_{W(L)}$	Minimum Pulse Width (CLOCK)	2.0				28	75		95		110	ns
		4.5				7	15		19		22	
		6.0				6	13		16		19	
$t_{W(L)}$	Minimum Pulse Width (CLEAR)	2.0				28	75		95		110	ns
		4.5				7	15		19		22	
		6.0				6	13		16		19	
$t_s$	Minimum Set-up Time	2.0				28	75		95		110	ns
		4.5				7	15		19		22	
		6.0				6	13		16		19	
$t_h$	Minimum Hold Time	2.0					0		0		0	ns
		4.5					0		0		0	
		6.0					0		0		0	
$t_{REM}$	Minimum Removal Time (CLEAR)	2.0					5		5		5	ns
		4.5					5		5		5	
		6.0					5		5		5	

## CAPACITIVE CHARACTERISTICS

Symbol	Parameter	Test Condition		Value						Unit		
		$V_{CC}$ (V)		$T_A = 25^\circ\text{C}$			$-40$ to $85^\circ\text{C}$		$-55$ to $125^\circ\text{C}$			
				Min.	Typ.	Max.	Min.	Max.	Min.		Max.	
$C_{IN}$	Input Capacitance	5.0				5	10		10		10	pF
$C_{PD}$	Power Dissipation Capacitance (note 1)	5.0				47						pF

1)  $C_{PD}$  is defined as the value of the IC's internal equivalent capacitance which is calculated from the operating current consumption without load. (Refer to Test Circuit). Average operating current can be obtained by the following equation.  $I_{CC(opp)} = C_{PD} \times V_{CC} \times f_{IN} + I_{CC}/4$  (per FLIP/FLOP)

TEST CIRCUIT

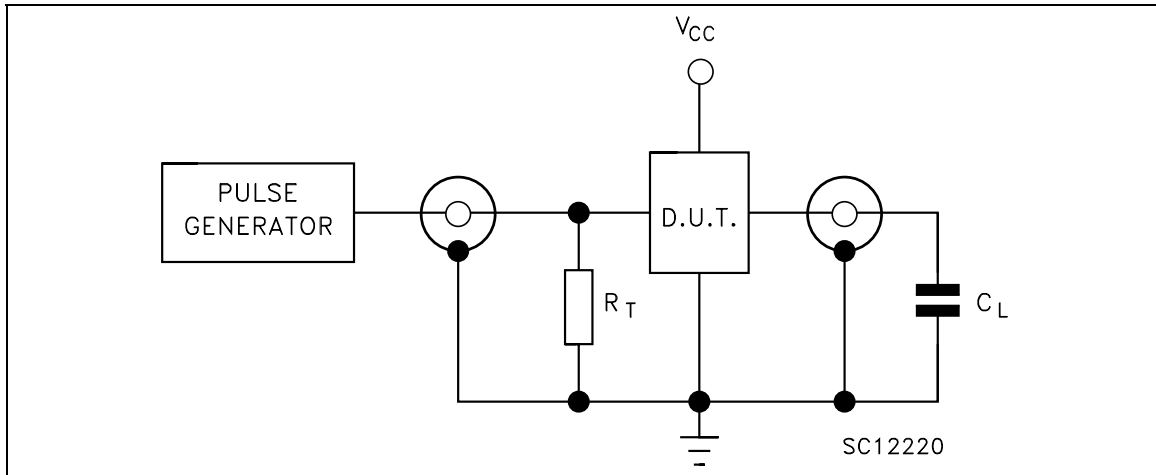

$C_L = 50\text{pF}$  or equivalent (includes jig and probe capacitance)  
 $R_T = Z_{OUT}$  of pulse generator (typically  $50\Omega$ )

WAVEFORM 1: PROPAGATION DELAY TIMES, MINIMUM PULSE WIDTH (CLOCK), SETUP AND HOLD TIME (D TO CLOCK) ( $f=1\text{MHz}$ ; 50% duty cycle)

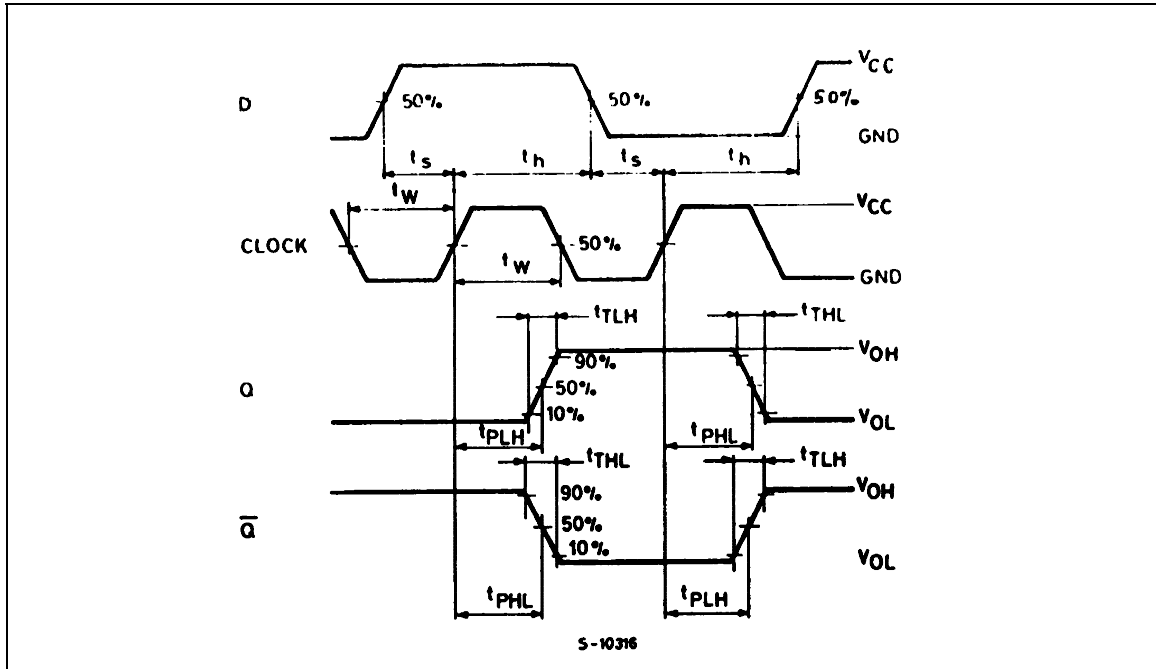

**WAVEFORM 2 : MINIMUM PULSE WIDTH ( $\overline{\text{CLEAR}}$ ) AND REMOVAL TIME ( $\overline{\text{CLEAR}}$  TO CLOCK)**

(f=1MHz; 50% duty cycle)

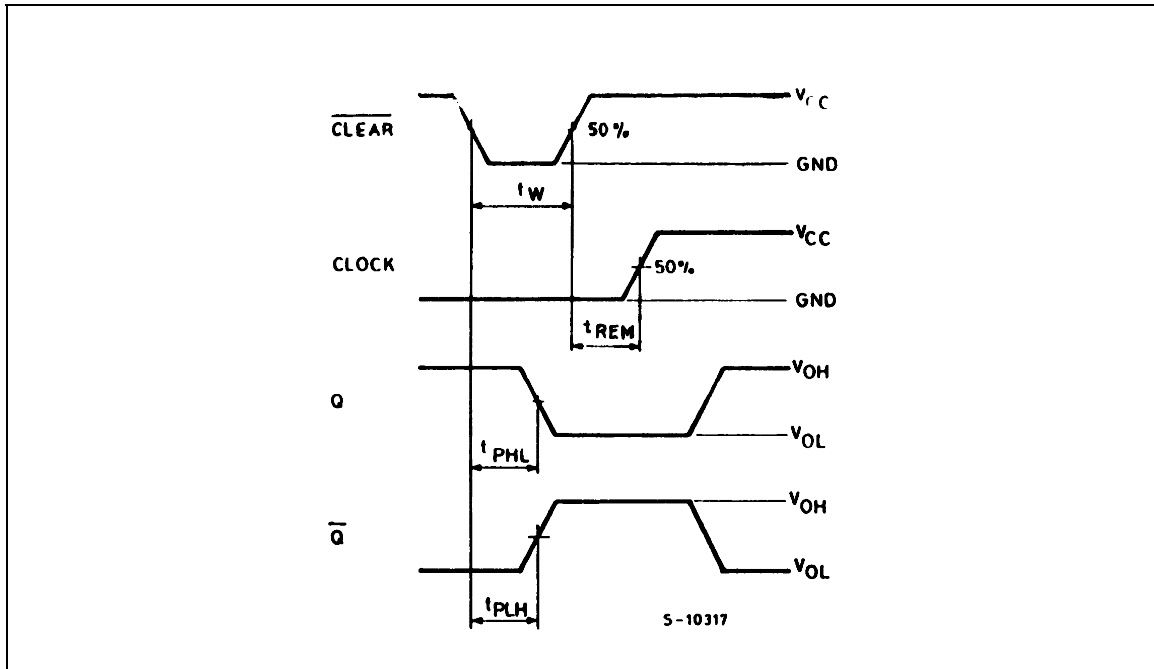
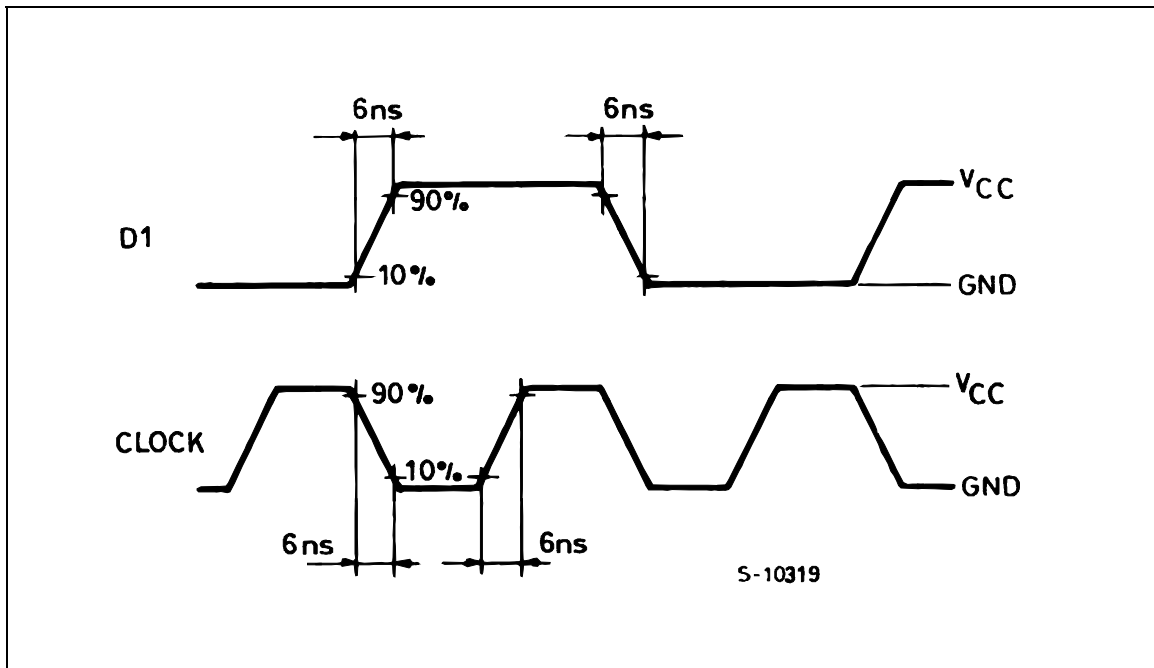
**WAVEFORM 3 : INPUT WAVEFORMS (f=1MHz; 50% duty cycle)**

**Plastic DIP-16 (0.25) MECHANICAL DATA**

DIM.	mm.			inch		
	MIN.	TYP	MAX.	MIN.	TYP.	MAX.
a1	0.51			0.020		
B	0.77		1.65	0.030		0.065
b		0.5			0.020	
b1		0.25			0.010	
D			20			0.787
E		8.5			0.335	
e		2.54			0.100	
e3		17.78			0.700	
F			7.1			0.280
I			5.1			0.201
L		3.3			0.130	
Z			1.27			0.050

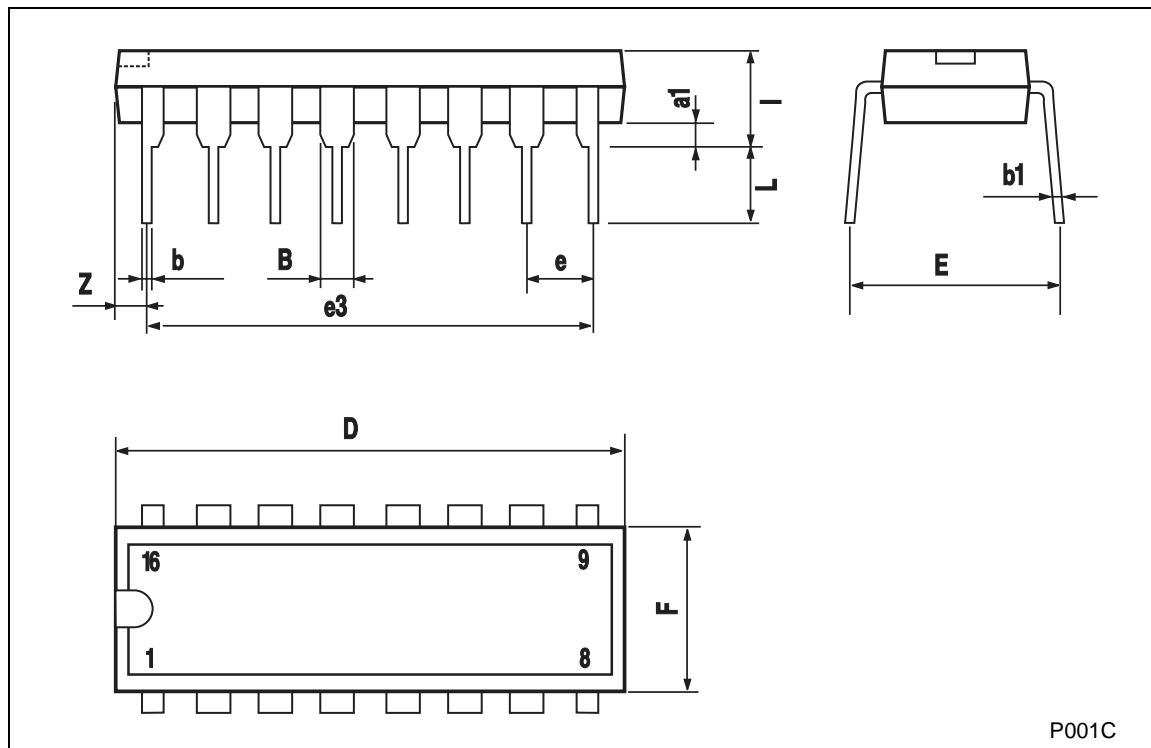

P001C



## SO-16 MECHANICAL DATA

DIM.	mm.			inch		
	MIN.	TYP	MAX.	MIN.	TYP.	MAX.
A			1.75			0.068
a1	0.1		0.2	0.003		0.007
a2			1.65			0.064
b	0.35		0.46	0.013		0.018
b1	0.19		0.25	0.007		0.010
C		0.5			0.019	
c1	45° (typ.)					
D	9.8		10	0.385		0.393
E	5.8		6.2	0.228		0.244
e		1.27			0.050	
e3		8.89			0.350	
F	3.8		4.0	0.149		0.157
G	4.6		5.3	0.181		0.208
L	0.5		1.27	0.019		0.050
M			0.62			0.024
S	8° (max.)					

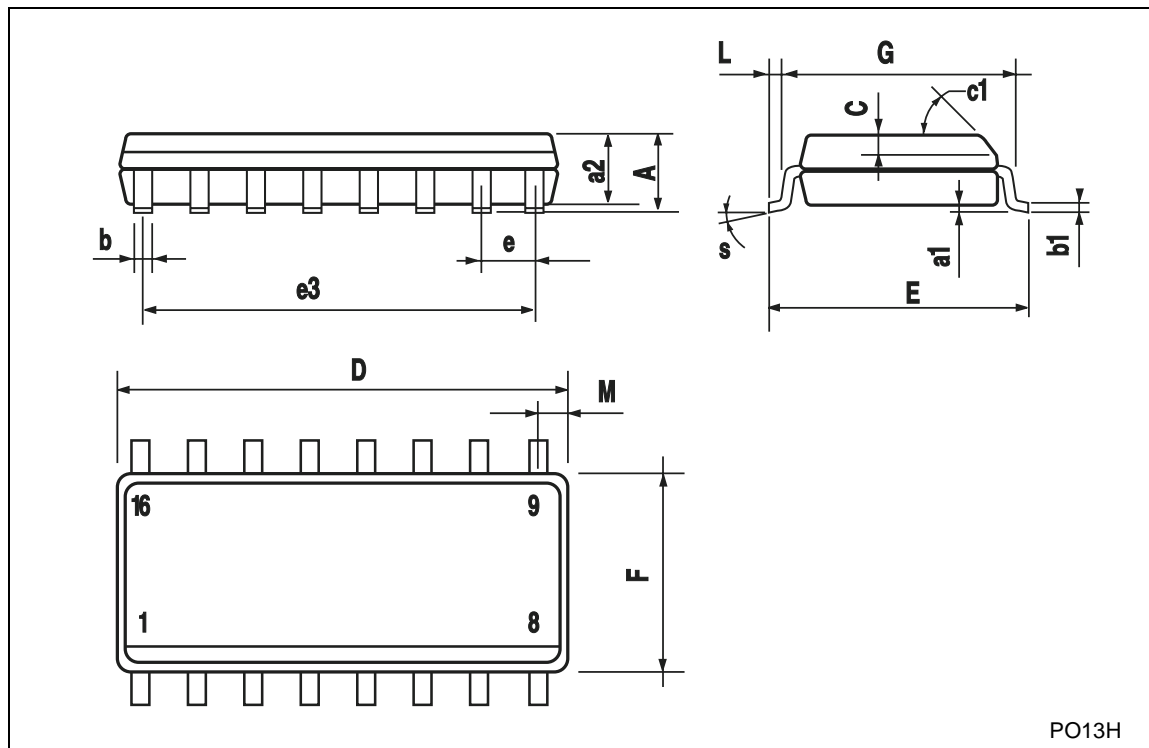

## TSSOP16 MECHANICAL DATA

DIM.	mm.			inch		
	MIN.	TYP	MAX.	MIN.	TYP.	MAX.
A			1.2			0.047
A1	0.05		0.15	0.002	0.004	0.006
A2	0.8	1	1.05	0.031	0.039	0.041
b	0.19		0.30	0.007		0.012
c	0.09		0.20	0.004		0.0089
D	4.9	5	5.1	0.193	0.197	0.201
E	6.2	6.4	6.6	0.244	0.252	0.260
E1	4.3	4.4	4.48	0.169	0.173	0.176
e		0.65 BSC			0.0256 BSC	
K	0°		8°	0°		8°
L	0.45	0.60	0.75	0.018	0.024	0.030

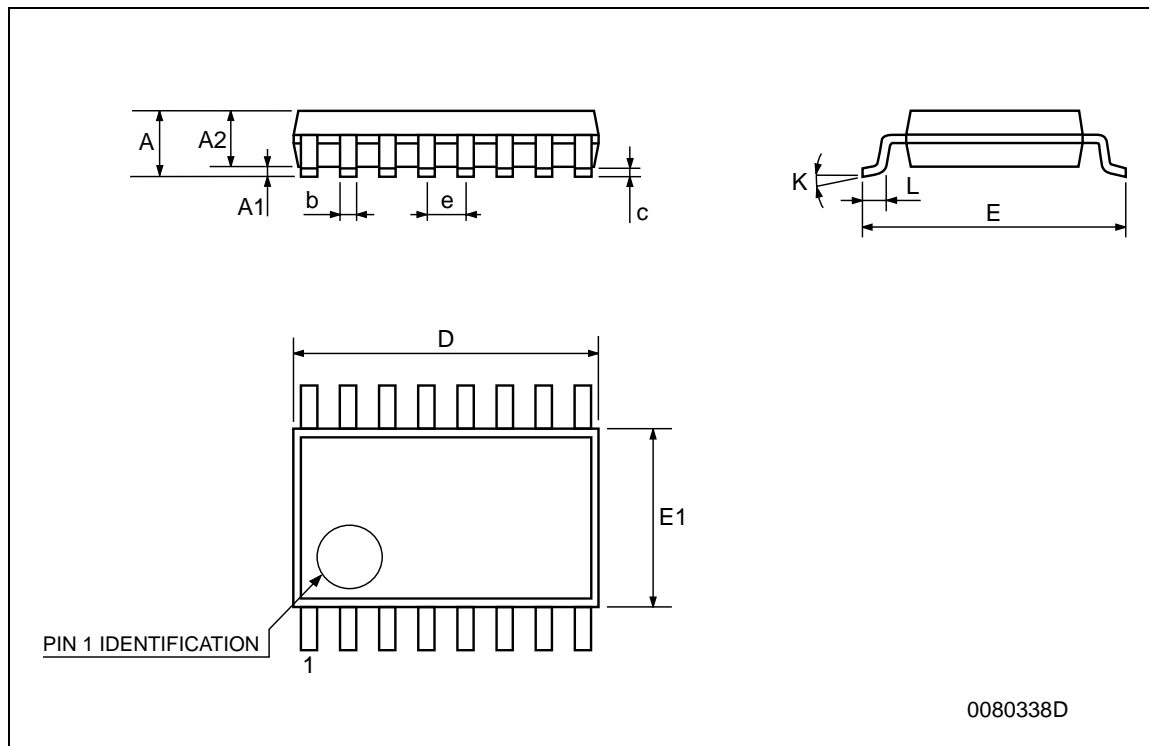

Information furnished is believed to be accurate and reliable. However, STMicroelectronics assumes no responsibility for the consequences of use of such information nor for any infringement of patents or other rights of third parties which may result from its use. No license is granted by implication or otherwise under any patent or patent rights of STMicroelectronics. Specifications mentioned in this publication are subject to change without notice. This publication supersedes and replaces all information previously supplied. STMicroelectronics products are not authorized for use as critical components in life support devices or systems without express written approval of STMicroelectronics.

© The ST logo is a registered trademark of STMicroelectronics

© 2001 STMicroelectronics - Printed in Italy - All Rights Reserved  
STMicroelectronics GROUP OF COMPANIES

Australia - Brazil - China - Finland - France - Germany - Hong Kong - India - Italy - Japan - Malaysia - Malta - Morocco  
Singapore - Spain - Sweden - Switzerland - United Kingdom

© <http://www.st.com>

