



32-Tap Digitally Programmable Potentiometer (DPP™)

FEATURES

- 32-position linear taper potentiometer
- Low power CMOS technology
- Single supply operation: 2.5V – 6V
- Increment up/down serial interface
- Resistance values: 10kΩ, 50kΩ and 100kΩ
- Available in PDIP, SOIC, TSSOP, MSOP and space saving 2 x 2.5mm TDFN packages

APPLICATIONS

- Automated product calibration
- Remote control adjustments
- Offset, gain and zero control
- Tamper-proof calibrations
- Contrast, brightness and volume controls
- Motor controls and feedback systems
- Programmable analog functions

For Ordering Information details, see page 13.

DESCRIPTION

The CAT5115 is a single digitally programmable potentiometer (DPP™) designed as a electronic replacement for mechanical potentiometers and trim pots. Ideal for automated adjustments on high volume production lines, they are also well suited for applications where equipment requiring periodic adjustment is either difficult to access or located in a hazardous or remote environment.

The CAT5115 contains a 32-tap series resistor array connected between two terminals R_H and R_L . An up/down counter and decoder that are controlled by three input pins, determines which tap is connected to the wiper, R_W . The wiper is always set to the mid point, tap 15 at power up. The tap position is not stored in memory. Wiper-control of the CAT5115 is accomplished with three input control pins, \overline{CS} , U/\overline{D} , and \overline{INC} . The \overline{INC} input increments the wiper in the direction which is determined by the logic state of the U/\overline{D} input. The \overline{CS} input is used to select the device.

The digitally programmable potentiometer can be used as a three-terminal resistive divider or as a two-terminal variable resistor. DPPs bring variability and programmability to a wide variety of applications including control, parameter adjustments, and signal processing.

For a pin-compatible device that recalls a stored tap position on power-up refer to the CAT5114 data sheet.

FUNCTIONAL DIAGRAM

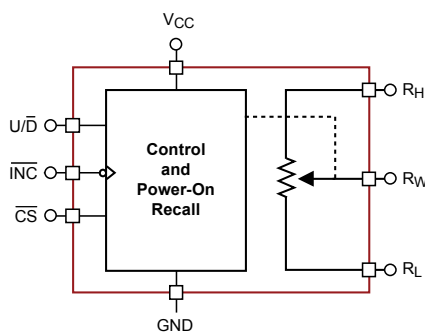

General

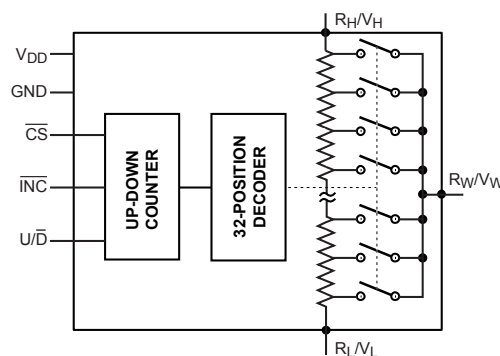

Detailed

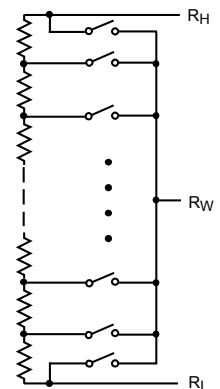

Electronic Potentiometer Implementation

PIN CONFIGURATION

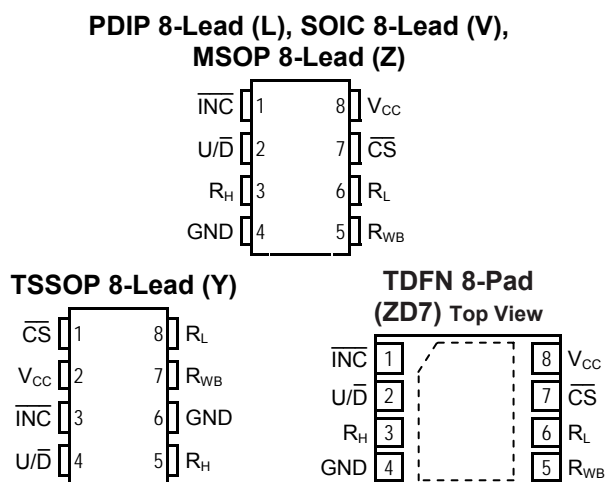

PIN DESCRIPTIONS

Name	Function
$\overline{\text{INC}}$	Increment Control
$\text{U}/\overline{\text{D}}$	Up/Down Control
R_H	Potentiometer High Terminal
GND	Ground
R_W	Buffered Wiper Terminal
R_L	Potentiometer Low Terminal
$\overline{\text{CS}}$	Chip Select
V_{CC}	Supply Voltage

PIN FUNCTION

$\overline{\text{INC}}$: Increment Control Input

The $\overline{\text{INC}}$ input moves the wiper in the up or down direction determined by the condition of the $\text{U}/\overline{\text{D}}$ input.

$\text{U}/\overline{\text{D}}$: Up/Down Control Input

The $\text{U}/\overline{\text{D}}$ input controls the direction of the wiper movement. When in a high state and $\overline{\text{CS}}$ is low, any high-to-low transition on $\overline{\text{INC}}$ will cause the wiper to move one increment toward the R_H terminal. When in a low state and $\overline{\text{CS}}$ is low, any high-to-low transition on $\overline{\text{INC}}$ will cause the wiper to move one increment towards the R_L terminal.

R_H : High End Potentiometer Terminal

R_H is the high end terminal of the potentiometer. It is not required that this terminal be connected to a potential greater than the R_L terminal. Voltage applied to the R_H terminal cannot exceed the supply voltage, V_{CC} or go below ground, GND.

R_W : Wiper Potentiometer Terminal

R_W is the wiper terminal of the potentiometer. Its position on the resistor array is controlled by the control inputs, $\overline{\text{INC}}$, $\text{U}/\overline{\text{D}}$ and $\overline{\text{CS}}$. Voltage applied to the R_W terminal cannot exceed the supply voltage, V_{CC} or go below ground, GND.

R_L : Low End Potentiometer Terminal

R_L is the low end terminal of the potentiometer. It is not required that this terminal be connected to a potential less than the R_H terminal. Voltage applied to the R_L terminal cannot exceed the supply voltage, V_{CC} or go below ground, GND. R_L and R_H are electrically interchangeable.

$\overline{\text{CS}}$: Chip Select

The chip select input is used to activate the control input of the CAT5115 and is active low. When in a high state, activity on the $\overline{\text{INC}}$ and $\text{U}/\overline{\text{D}}$ inputs will not affect or change the position of the wiper.

DEVICE OPERATION

The CAT5115 operates like a digitally controlled potentiometer with R_H and R_L equivalent to the high and low terminals and R_W equivalent to the mechanical potentiometer's wiper. There are 32 available tap positions including the resistor end points, R_H and R_L . There are 31 resistor elements connected in series between the R_H and R_L terminals. The wiper terminal is connected to one of the 32 taps and controlled by three inputs, $\overline{\text{INC}}$, $\text{U}/\overline{\text{D}}$ and $\overline{\text{CS}}$. These inputs control a five-bit up/down counter whose output is decoded to select the wiper position.

With $\overline{\text{CS}}$ set LOW the CAT5115 is selected and will respond to the $\text{U}/\overline{\text{D}}$ and $\overline{\text{INC}}$ inputs. HIGH to LOW transitions on $\overline{\text{INC}}$ will increment or decrement the wiper (depending on the state of the $\text{U}/\overline{\text{D}}$ input and five-bit counter). The wiper, when at either fixed terminal, acts like its mechanical equivalent and does not move beyond the last position. When the CAT5115 is powered-down, the wiper position is reset. When power is restored, the counter is set to the mid point, tap 15.

OPERATION MODES

\overline{INC}	\overline{CS}	U/\overline{D}	Operation
High to Low	Low	High	Wiper toward H
High to Low	Low	Low	Wiper toward L
High	Low to High	X	Store Wiper Position
Low	Low to High	X	No Store, Return to Standby
X	High	X	Standby

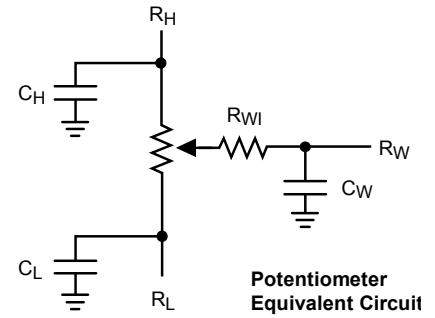

ABSOLUTE MAXIMUM RATINGS ⁽¹⁾

Parameters	Ratings	Units
Supply Voltage V_{CC} to GND	-0.5 to +7V	V
Inputs		
\overline{CS} to GND	-0.5 to $V_{CC} + 0.5$	V
\overline{INC} to GND	-0.5 to $V_{CC} + 0.5$	V
U/\overline{D} to GND	-0.5 to $V_{CC} + 0.5$	V
H to GND	-0.5 to $V_{CC} + 0.5$	V
L to GND	-0.5 to $V_{CC} + 0.5$	V
W to GND	-0.5 to $V_{CC} + 0.5$	V

Parameters	Ratings	Units
Operating Ambient Temperature Industrial ('I' suffix)	-40 to +85	°C
Junction Temperature	+150	°C
Storage Temperature	-65 to 150	°C
Lead Soldering (10s max)	+300	°C

RELIABILITY CHARACTERISTICS

Symbol	Parameter	Test Method	Min	Typ	Max	Units
$V_{ZAP}^{(2)}$	ESD Susceptibility	MIL-STD-883, Test Method 3015	2000			V
$I_{LTH}^{(2)(3)}$	Latch-Up	JEDEC Standard 17	100			mA
T_{DR}	Data Retention	MIL-STD-883, Test Method 1008	100			Years
N_{END}	Endurance	MIL-STD-883, Test Method 1003	1,000,000			Stores

DC ELECTRICAL CHARACTERISTICS

$V_{CC} = +2.5V$ to $+6V$ unless otherwise specified

Power Supply

Symbol	Parameter	Conditions	Min	Typ	Max	Units
V_{CC}	Operating Voltage Range		2.5	–	6	V
I_{CC1}	Supply Current (Increment)	$V_{CC} = 6V, f = 1MHz, I_W = 0$	–	–	100	μA
		$V_{CC} = 6V, f = 250kHz, I_W = 0$	–	–	50	μA
$I_{SB1}^{(3)}$	Supply Current (Standby)	$\overline{CS} = V_{CC} - 0.3V$ $U/\overline{D}, \overline{INC} = V_{CC} - 0.3V$ or GND	–	0.01	1	μA

Notes:

- (1) Stresses above those listed under "Absolute Maximum Ratings" may cause permanent damage to the device. These are stress ratings only, and functional operation of the device at these or any other conditions outside of those listed in the operational sections of this specification is not implied. Exposure to any absolute maximum rating for extended periods may affect device performance and reliability.
- (2) This parameter is tested initially and after a design or process change that affects the parameter.
- (3) Latch-up protection is provided for stresses up to 100mA on address and data pins from $-1V$ to $V_{CC} + 1V$.
- (4) I_W = source or sink.
- (5) These parameters are periodically sampled and are not 100% tested.

Logic Inputs

Symbol	Parameter	Conditions	Min	Typ	Max	Units
I_{IH}	Input Leakage Current	$V_{IN} = V_{CC}$	–	–	10	μA
I_{IL}	Input Leakage Current	$V_{IN} = 0V$	–	–	-10	μA
V_{IH1}	TTL High Level Input Voltage	$4.5V \leq V_{CC} \leq 5.5V$	2	–	V_{CC}	V
V_{IL1}	TTL Low Level Input Voltage		0	–	0.8	V
V_{IH2}	CMOS High Level Input Voltage	$2.5V \leq V_{CC} \leq 6V$	$V_{CC} \times 0.7$	–	$V_{CC} + 0.3$	V
V_{IL2}	CMOS Low Level Input Voltage		-0.3	–	$V_{CC} \times 0.2$	V

Potentiometer Characteristics

Symbol	Parameter	Conditions	Min	Typ	Max	Units
R_{POT}	Potentiometer Resistance	-10 Device		10		k Ω
		-50 Device		50		
		-00 Device		100		
	Pot. Resistance Tolerance				± 20	%
V_{RH}	Voltage on R_H pin		0		V_{CC}	V
V_{RL}	Voltage on R_L pin		0		V_{CC}	V
	Resolution			3.2		%
INL	Integral Linearity Error	$I_W \leq 2\mu A$		0.5	1	LSB
DNL	Differential Linearity Error	$I_W \leq 2\mu A$		0.25	0.5	LSB
R_{WI}	Wiper Resistance	$V_{CC} = 5V, I_W = 1mA$		70	200	Ω
		$V_{CC} = 2.5V, I_W = 1mA$		150	400	Ω
I_W	Wiper Current	(1)			1	mA
TC_{RPOT}	TC of Pot Resistance			± 50	± 300	ppm/ $^{\circ}C$
TC_{RATIO}	Ratiometric TC				20	ppm/ $^{\circ}C$
V_N	Noise	100kHz / 1kHz		8/24		nV/ \sqrt{Hz}
$C_H/C_L/C_W$	Potentiometer Capacitances			8/8/25		pF
fc	Frequency Response	Passive Attenuator, 10k Ω		1.7		MHz

AC CONDITIONS OF TEST

V _{CC} Range	2.5V ≤ V _{CC} ≤ 6.0V
Input Pulse Levels	0.2V _{CC} to 0.7V _{CC}
Input Rise and Fall Times	10ns
Input Reference Levels	0.5V _{CC}

AC OPERATING CHARACTERISTICS

V_{CC} = +2.5V to +6.0V, V_H = V_{CC}, V_L = 0V, unless otherwise specified

Symbol	Parameter	Min	Typ ⁽¹⁾	Max	Units
t _{CI}	\overline{CS} to \overline{INC} Setup	100	–	–	ns
t _{DI}	U/ \overline{D} to \overline{INC} Setup	50	–	–	ns
t _{ID}	U/ \overline{D} to \overline{INC} Hold	100	–	–	ns
t _{IL}	\overline{INC} LOW Period	250	–	–	ns
t _{IH}	\overline{INC} HIGH Period	250	–	–	ns
t _{IC}	\overline{INC} Inactive to \overline{CS} Inactive	1	–	–	μs
t _{CPH}	\overline{CS} Deselect Time	100	–	–	ns
t _{IW}	\overline{INC} to V _{OUT} Change	–	1	5	μs
t _{CYC}	\overline{INC} Cycle Time	1	–	–	μs
t _R , t _F ⁽²⁾	\overline{INC} Input Rise and Fall Time	–	–	500	μs
t _{PU} ⁽²⁾	Power-up to Wiper Stable	–	–	1	ms

A.C. TIMING

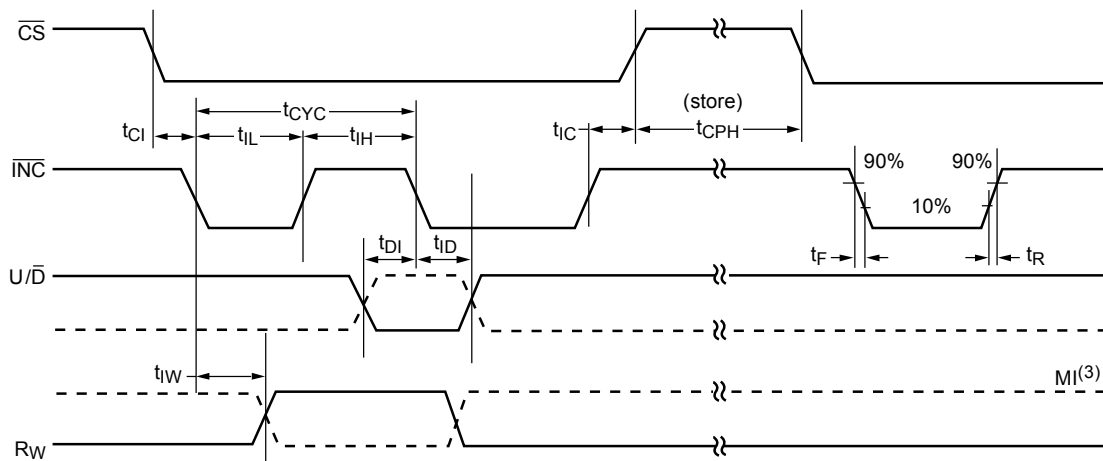

Notes:

- (1) Typical values are for T_A = 25°C and nominal supply voltage.
- (2) This parameter is periodically sampled and not 100% tested.
- (3) MI in the A.C. Timing diagram refers to the minimum incremental change in the W output due to a change in the wiper position.

APPLICATIONS INFORMATION

POTENTIOMETER CONFIGURATION

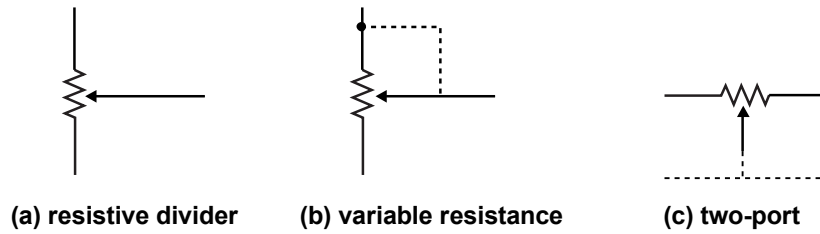

APPLICATIONS

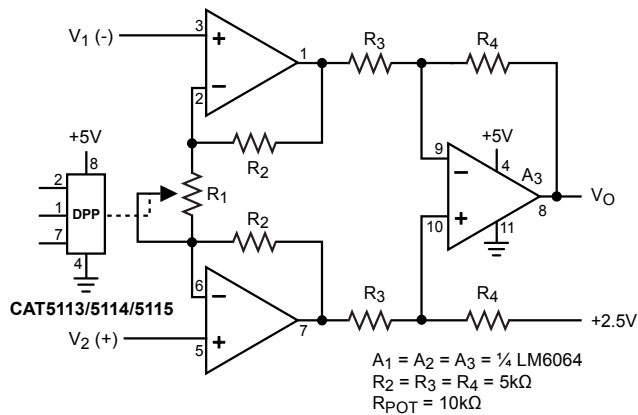

Programmable Instrumentation Amplifier

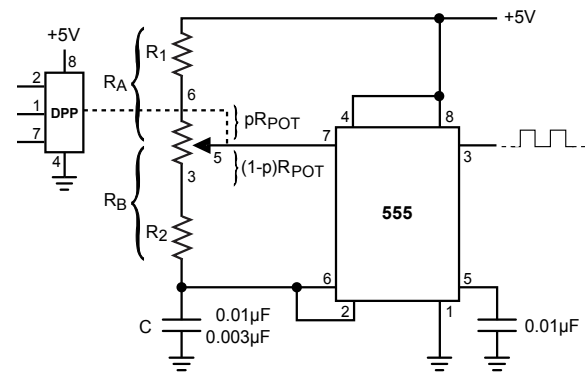

Programmable Sq. Wave Oscillator (555)

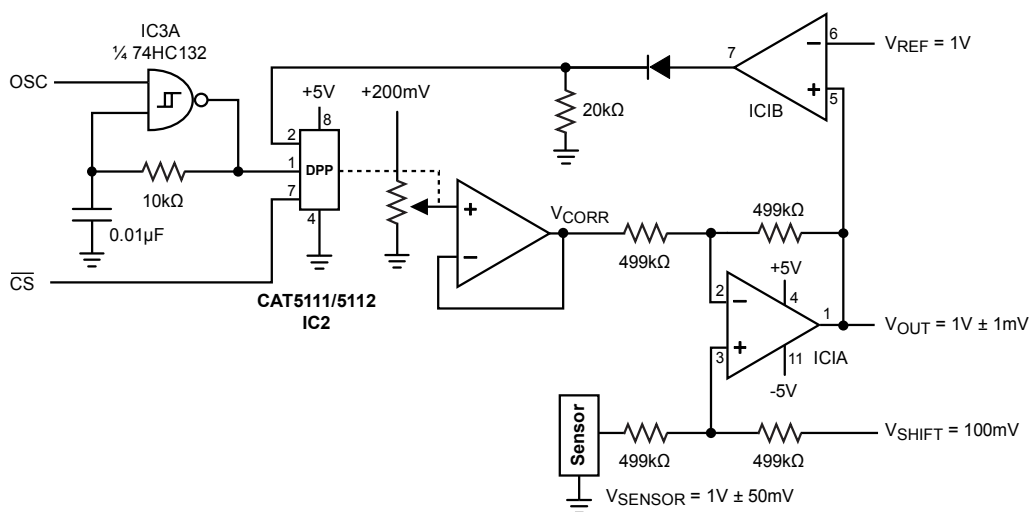

Sensor Auto Referencing Circuit

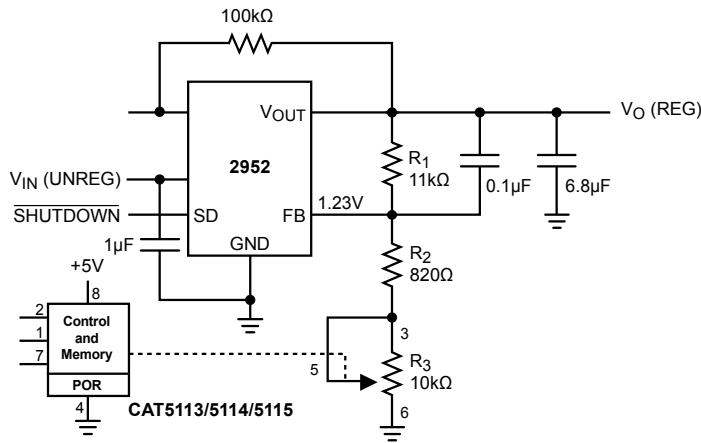

Programmable Voltage Regulator

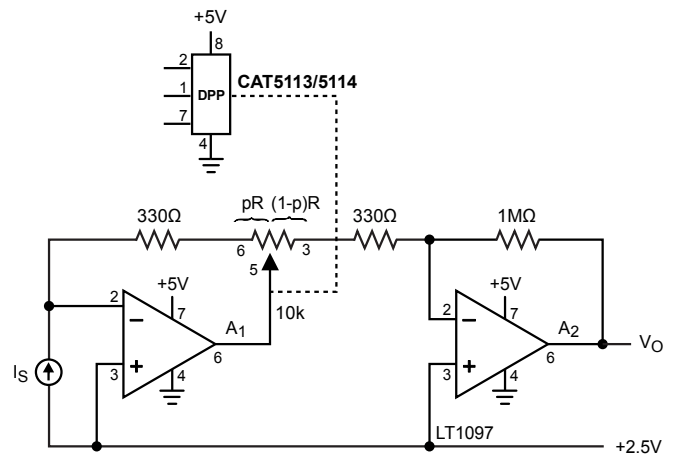

Programmable I to V Converter

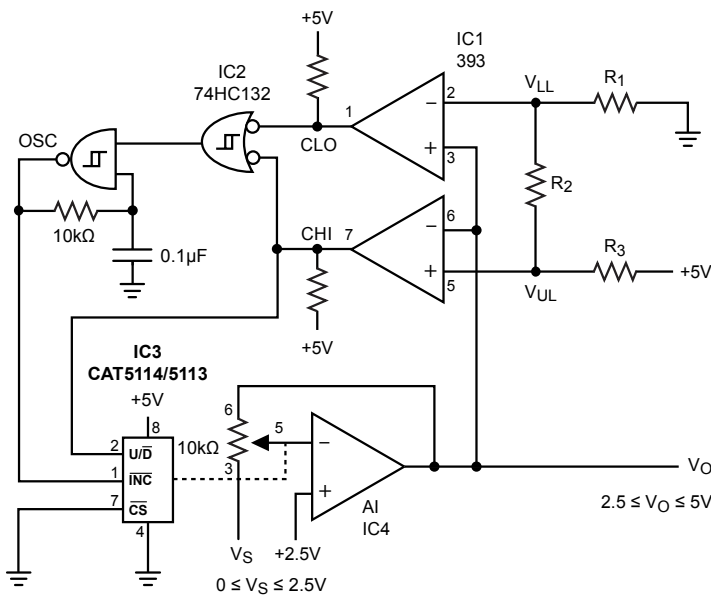

Automatic Gain Control

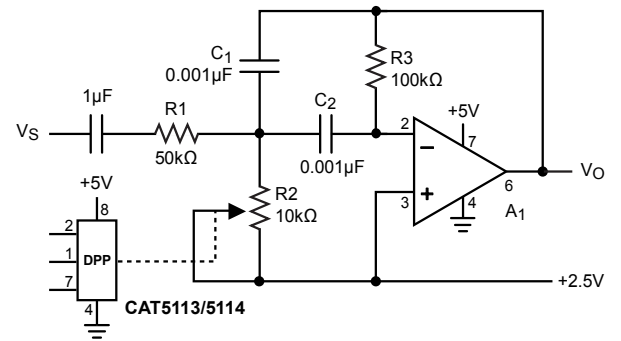

Programmable Bandpass Filter

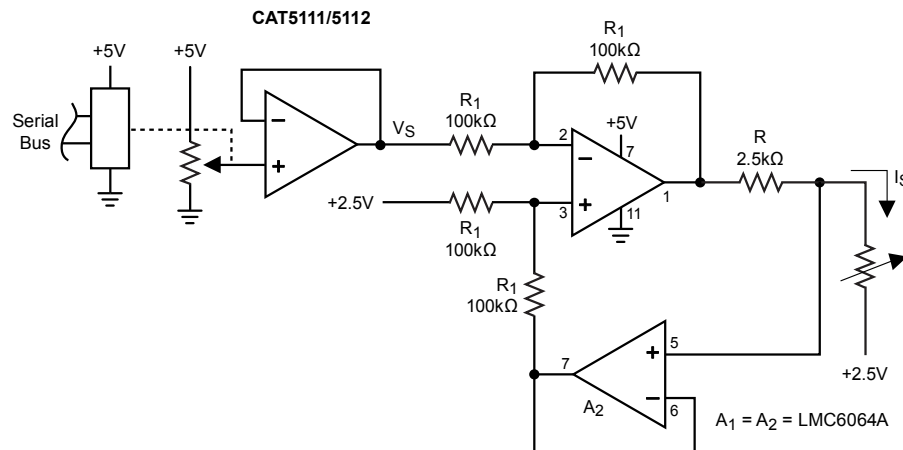

Programmable Current Source/Sink

PACKAGE OUTLINE DRAWINGS

PDIP 8-Lead 300mils (L) ⁽¹⁾⁽²⁾

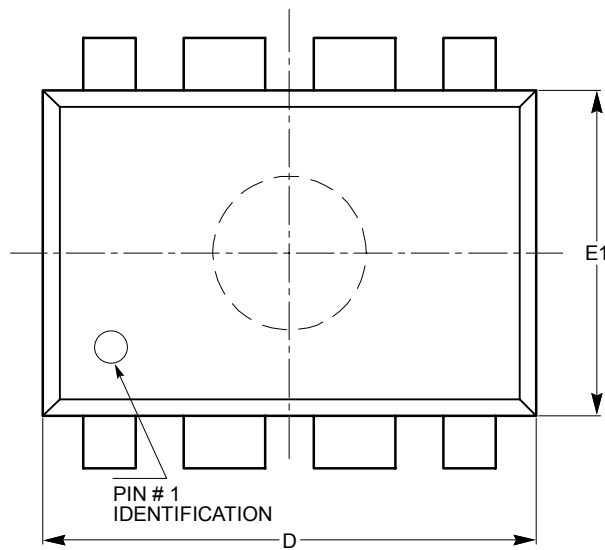

TOP VIEW

SYMBOL	MIN	NOM	MAX
A			5.33
A1	0.38		
A2	2.92	3.30	4.95
b	0.36	0.46	0.56
b2	1.14	1.52	1.78
c	0.20	0.25	0.36
D	9.02	9.27	10.16
E	7.62	7.87	8.25
e	2.54 BSC		
E1	6.10	6.35	7.11
eB	7.87		10.92
L	2.92	3.30	3.80

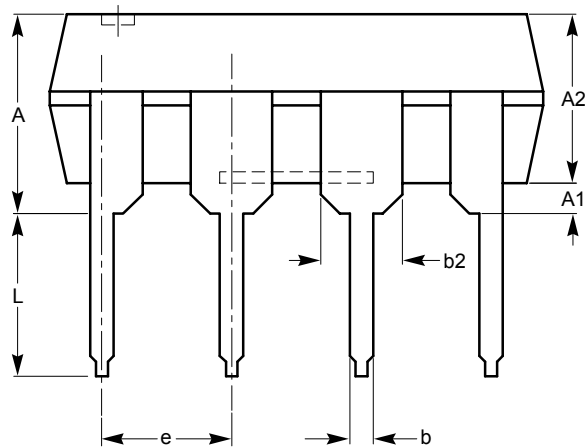

SIDE VIEW

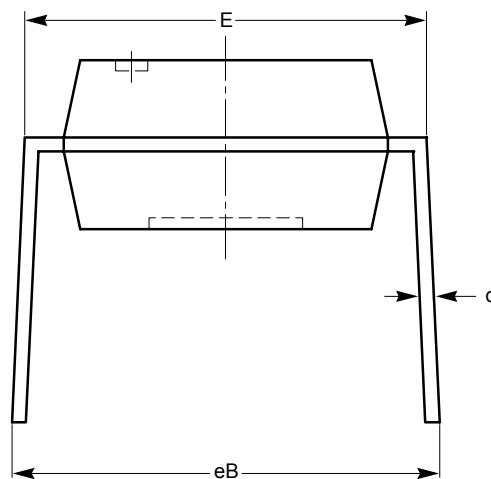

END VIEW

For current Tape and Reel information, download the PDF file from:
<http://www.catsemi.com/documents/tapeand reel.pdf>.

Notes:

- (1) All dimensions are in millimeters.
- (2) Complies with JEDEC standard MS-001.

SOIC 8-Lead 150mils (V) ⁽¹⁾⁽²⁾

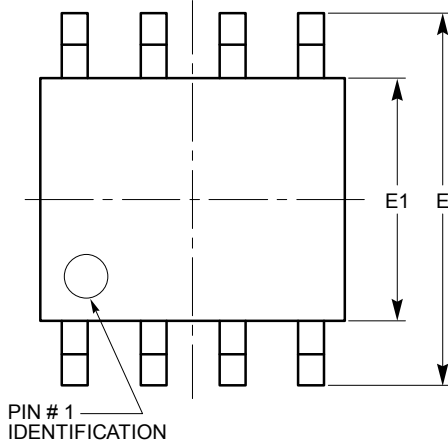

TOP VIEW

SYMBOL	MIN	NOM	MAX
A	1.35		1.75
A1	0.10		0.25
b	0.33		0.51
c	0.19		0.25
D	4.80		5.00
E	5.80		6.20
E1	3.80		4.00
e	1.27 BSC		
h	0.25		0.50
L	0.40		1.27
θ	0°		8°

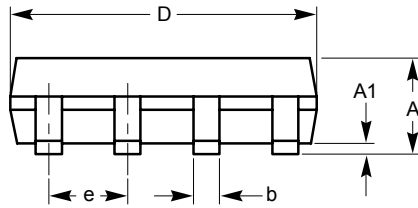

SIDE VIEW

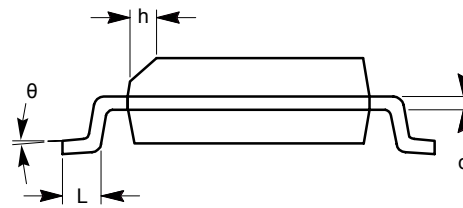

END VIEW

For current Tape and Reel information, download the PDF file from:
<http://www.catsemi.com/documents/tapeandreel.pdf>.

Notes:

- (1) All dimensions are in millimeters. Angles in degrees.
- (2) Complies with JEDEC standard MS-012.

TSSOP 8-Lead 4.4mm (Y) ⁽¹⁾⁽²⁾

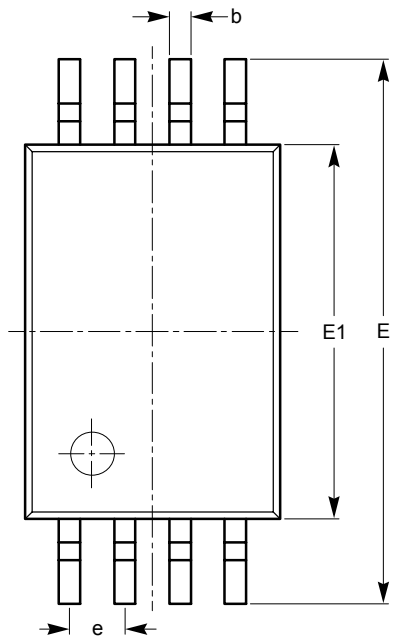

TOP VIEW

SYMBOL	MIN	NOM	MAX
A			1.20
A1	0.05		0.15
A2	0.80	0.90	1.05
b	0.19		0.30
c	0.09		0.20
D	2.90	3.00	3.10
E	6.30	6.40	6.50
E1	4.30	4.40	4.50
e	0.65 BSC		
L	1.00 REF		
L1	0.50	0.60	0.75
θ1	0°		8°

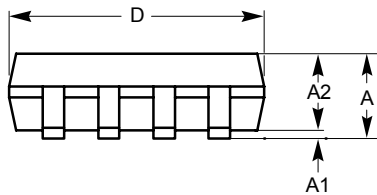

SIDE VIEW

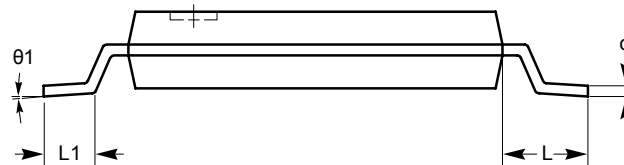

END VIEW

For current Tape and Reel information, download the PDF file from:
<http://www.catsemi.com/documents/tapeandreeel.pdf>.

Notes:

- (1) All dimensions are in millimeters. Angles in degrees.
- (2) Complies with JEDEC standard MO-153.

MSOP 8-Lead 3.0 x 3.0mm (Z) ⁽¹⁾⁽²⁾

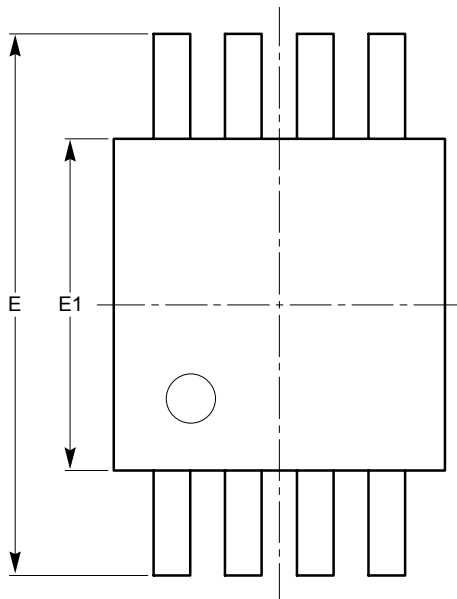

TOP VIEW

SYMBOL	MIN	NOM	MAX
A			1.10
A1	0.05	0.10	0.15
A2	0.75	0.85	0.95
b	0.22		0.38
c	0.13		0.23
D	2.90	3.00	3.10
E	4.80	4.90	5.00
E1	2.90	3.00	3.10
e	0.65 BSC		
L	0.40	0.60	0.80
L1	0.95 REF		
L2	0.25 BSC		
θ	0°		6°

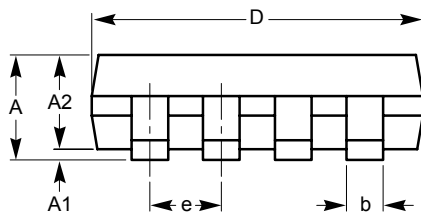

SIDE VIEW

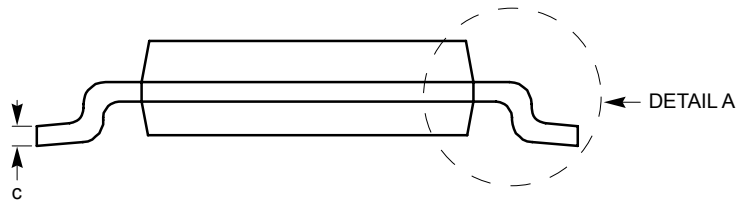

END VIEW

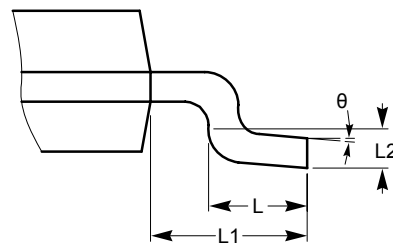

DETAIL A

For current Tape and Reel information, download the PDF file from:
<http://www.catsemi.com/documents/tapeandreeel.pdf>.

Notes:

- (1) All dimensions are in millimeters. Angles in degrees.
- (2) Complies with JEDEC standard MO-187.

TDFN 8-Pad 2 x 2.5mm (ZD7) ⁽¹⁾⁽²⁾

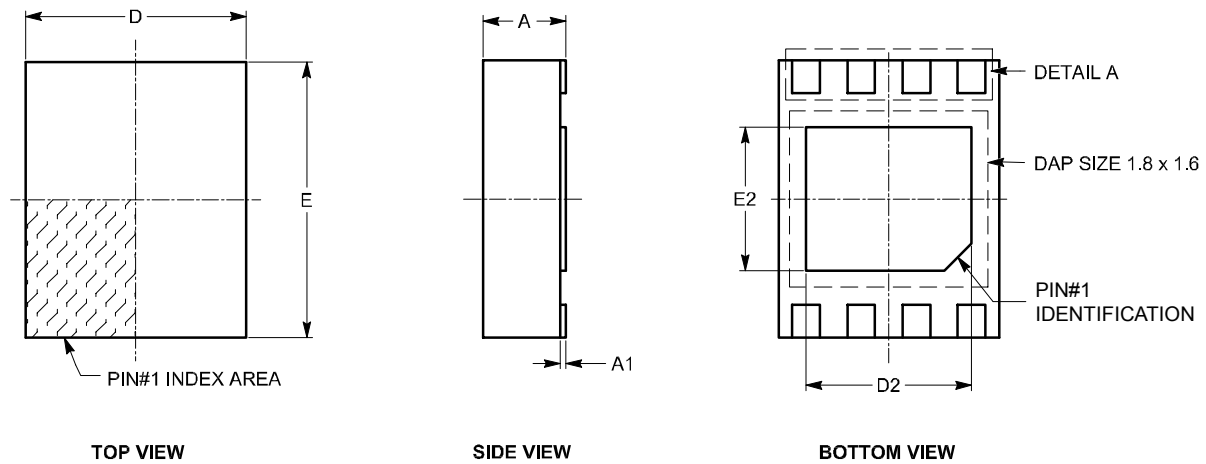

SYMBOL	MIN	NOM	MAX
A	0.70	0.75	0.80
A1	0.00	0.02	0.05
A3	0.20 REF		
b	0.20	0.25	0.30
D	1.90	2.00	2.10
D2	1.40	1.50	1.60
E	2.40	2.50	2.60
E2	1.20	1.30	1.40
e	0.50 TYP		
L	0.20	0.30	0.40

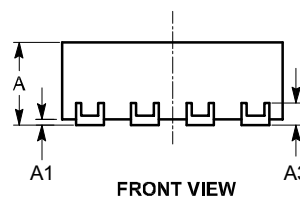
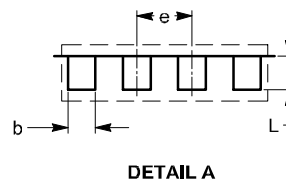

For current Tape and Reel information, download the PDF file from:
<http://www.catsemi.com/documents/tapeandreel.pdf>.

Notes:

- (1) All dimensions are in millimeters.
- (2) Complies with JEDEC standard MO-229.

EXAMPLE OF ORDERING INFORMATION

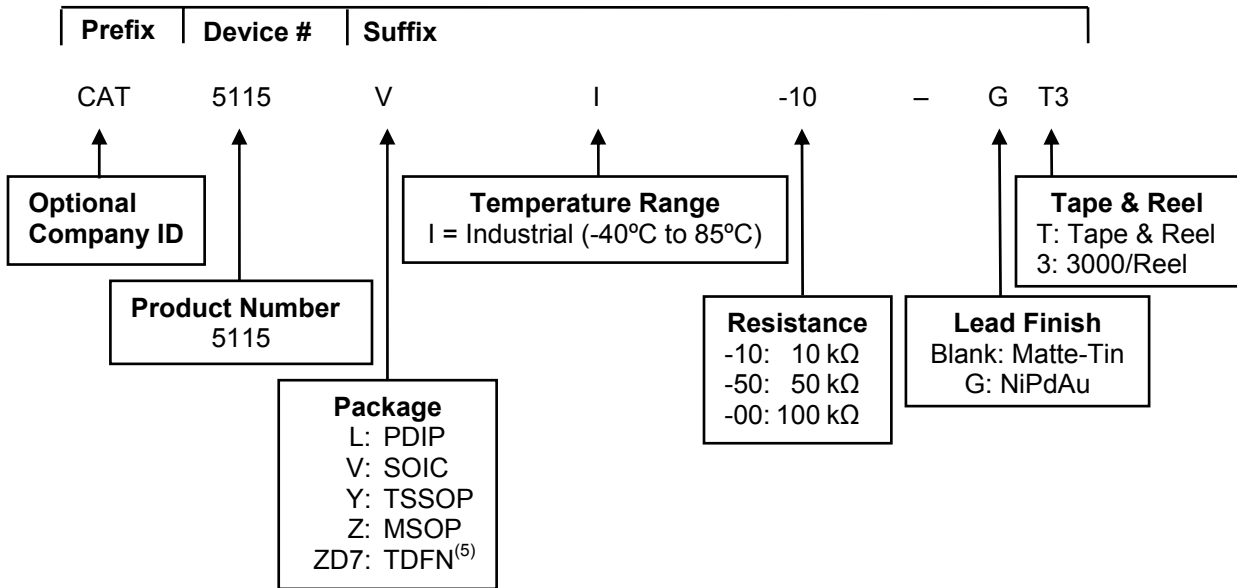

ORDERING PART NUMBER
CAT5115LI-10-G
CAT5115LI-50-G
CAT5115LI-00-G
CAT5115VI-10-G
CAT5115VI-50-G
CAT5115VI-00-G
CAT5115YI-10-G
CAT5115YI-50-G
CAT5115YI-00-G
CAT5115ZI-10-G
CAT5115ZI-50-G
CAT5115ZI-00-G
CAT5115ZD7I-10 ⁽⁶⁾
CAT5115ZD7I-50 ⁽⁶⁾
CAT5115ZD7I-00 ⁽⁶⁾

Notes:

- (1) All packages are RoHS-compliant (Lead-free, Halogen-free).
- (2) The standard lead finish is NiPdAu.
- (3) This device used in the above example is a CAT5115VI-10-GT3 (SOIC, Industrial Temperature, 10kΩ, NiPdAu, Tape & Reel).
- (4) For additional package and temperature options, please contact your nearest Catalyst Semiconductor Sales office.
- (5) TDFN is not available in NiPdAu (-G) version.
- (6) Contact factory for package availability.

REVISION HISTORY

Date	Rev.	Reason
09/25/2003	B	Changed designation to Preliminary. Updated Description. Updated Potentiometer Parameters table.
03/10/2004	C	Updated Potentiometer Parameters table.
03/29/2004	D	Changed Green Package marking for SOIC from W to V
04/12/2004	E	Updated Tape and Reel specs in Ordering Information
08/31/2004	F	Deleted ICC2 from DC Characteristics table Updated AC Operating Characteristics table Updated A.C. Timing diagram.
07/06/2007	G	Update Absolute Maximum Ratings table Update DC Electrical Characteristics tables Update AC Conditions of Test table Update all Package Outline Drawings Update Example of Ordering Information Update Ordering Part Number
02/04/2008	H	Update Functional Diagram Update Package Outline Drawings

Copyrights, Trademarks and Patents

© Catalyst Semiconductor, Inc.

Trademarks and registered trademarks of Catalyst Semiconductor include each of the following:

Adaptive Analog™, Beyond Memory™, DPP™, EZDim™, LDD™, MiniPot™, Quad-Mode™ and Quantum Charge Programmable™

Catalyst Semiconductor has been issued U.S. and foreign patents and has patent applications pending that protect its products.

CATALYST SEMICONDUCTOR MAKES NO WARRANTY, REPRESENTATION OR GUARANTEE, EXPRESS OR IMPLIED, REGARDING THE SUITABILITY OF ITS PRODUCTS FOR ANY PARTICULAR PURPOSE, NOR THAT THE USE OF ITS PRODUCTS WILL NOT INFRINGE ITS INTELLECTUAL PROPERTY RIGHTS OR THE RIGHTS OF THIRD PARTIES WITH RESPECT TO ANY PARTICULAR USE OR APPLICATION AND SPECIFICALLY DISCLAIMS ANY AND ALL LIABILITY ARISING OUT OF ANY SUCH USE OR APPLICATION, INCLUDING BUT NOT LIMITED TO, CONSEQUENTIAL OR INCIDENTAL DAMAGES.

Catalyst Semiconductor products are not designed, intended, or authorized for use as components in systems intended for surgical implant into the body, or other applications intended to support or sustain life, or for any other application in which the failure of the Catalyst Semiconductor product could create a situation where personal injury or death may occur.

Catalyst Semiconductor reserves the right to make changes to or discontinue any product or service described herein without notice. Products with data sheets labeled "Advance Information" or "Preliminary" and other products described herein may not be in production or offered for sale.

Catalyst Semiconductor advises customers to obtain the current version of the relevant product information before placing orders. Circuit diagrams illustrate typical semiconductor applications and may not be complete.



Catalyst Semiconductor, Inc.
Corporate Headquarters
2975 Stender Way
Santa Clara, CA 95054
Phone: 408.542.1000
Fax: 408.542.1200
www.catsemi.com

Document No: MD-2117
Revision: H
Issue date: 02/04/08