

Features

- Plug-in Modules for 19"-Subracks (3U and 6U Height)
- Available DC-Input Voltage Ranges 18-36,36-75,80-160 and 160-320VDC
- Also Models with AC-Input (see page 6)
- Standard Output Voltages: 5-250VDC, up to 200A
- EMI Compliance with EN 55022 class A
- Safety Compliance to IEC/EN 60950
- Many Options available, i.e. Powerfail Signals, Ext. On/Off, redundant Operation, Wall Mounting
- Customized Version available on request
- 3 Years Product Warranty



3U Models

The TSC series is a range high quality DC/DC converters qualified for demanding applications in industrial automation and telecom systems. The modular design allows a very high flexibility of input/output configuration and application specific options at very reasonable cost even for low quantities. All models are constructed as rugged plug-in module for 19"-subrack (Euro cassette) with wall mounting as option.



6U Models

Models					
		3U Height Modules		6U Height Modules	
Input voltage range	Output voltage (adjust. range)	Output current max.	Order code	Output current max.	Order code
18...36 VDC	5 VDC (4.5...5.5 VDC)	8 A	TSC 2020	25 A	TSC 1220
		20 A	TSC 3020	45 A	TSC 1320
		30 A	TSC 5020	60 A	TSC 1520
		50 A	TSC 0620	95 A	TSC 3520
		70 A	TSC 6020	135 A	TSC 3720
		85 A	TSC 2620	190 A	TSC 3620
	12 VDC (11...13 VDC)	4 A	TSC 2022	12.5 A	TSC 1222
		12 A	TSC 3022	25 A	TSC 1322
		16 A	TSC 5022	33 A	TSC 1522
		24 A	TSC 0622	50 A	TSC 3522
		35 A	TSC 6022	70 A	TSC 3722
		50 A	TSC 2622	100 A	TSC 3622
	24 VDC (23...26 VDC)	2 A	TSC 2024	6 A	TSC 1224
		6 A	TSC 3024	13 A	TSC 1324
		8 A	TSC 5024	18 A	TSC 1524
		12 A	TSC 0624	27 A	TSC 3524
		18 A	TSC 6024	40 A	TSC 3724
		25 A	TSC 2624	55 A	TSC 3624
	48 VDC (45...55 VDC)	1 A	TSC 2029	3 A	TSC 1229
		2.7 A	TSC 3029	6 A	TSC 1329
		4 A	TSC 5029	8 A	TSC 1529
6 A		TSC 0629	12 A	TSC 3529	
9 A		TSC 6029	19 A	TSC 3729	
12 A		TSC 2629	26 A	TSC 3629	
110 VDC (100...130 VDC)	0.5 A	TSC 2027	1.2 A	TSC 1227	
	1.2 A	TSC 3027	2.5 A	TSC 1327	
	1.8 A	TSC 5027	3.3 A	TSC 1527	
	2.5 A	TSC 0627	5.3 A	TSC 3527	
	3.5 A	TSC 6027	8 A	TSC 3727	
	5 A	TSC 2627	11 A	TSC 3627	
220 VDC (200...250 VDC)	0.25 A	TSC 2028	0.6 A	TSC 1228	
	0.6 A	TSC 3028	1.25 A	TSC 1328	
	0.9 A	TSC 5028	1.6 A	TSC 1528	
	1.25 A	TSC 0628	2.8 A	TSC 3528	
	1.8 A	TSC 6028	4 A	TSC 3728	
	2.5 A	TSC 2628	5.5 A	TSC 3628	
			8 A	TSC 3828	

Other output voltages on request

Height: 1U = 44.45 mm (1.75")

All specifications valid at nominal input voltage, full load and +25°C after warm-up time unless otherwise stated.

Models					
		3U Height Modules		6U Height Modules	
Input voltage range	Output voltage (adjust. range)	Output current max.	Order code	Output current max.	Order code
36...75 VDC	5 VDC (4.5...5.5 VDC)	8 A	TSC 2030	30 A	TSC 1230
		20 A	TSC 3030	50 A	TSC 1330
		35 A	TSC 5030	80 A	TSC 1530
		50 A	TSC 0630	110 A	TSC 3530
		80 A	TSC 6030	165 A	TSC 3730
		100 A	TSC 2630	220 A	TSC 3630
	12 VDC (11...13 VDC)	4 A	TSC 2032	15 A	TSC 1232
		12 A	TSC 3032	30 A	TSC 1332
		20 A	TSC 5032	42 A	TSC 1532
		26 A	TSC 0632	56 A	TSC 3532
		40 A	TSC 6032	85 A	TSC 3732
		60 A	TSC 2632	115 A	TSC 3632
	24 VDC (23...26 VDC)	2 A	TSC 2034	7.5 A	TSC 1234
		6 A	TSC 3034	15 A	TSC 1334
		10 A	TSC 5034	23 A	TSC 1534
		14 A	TSC 0634	30 A	TSC 3534
		20 A	TSC 6034	50 A	TSC 3734
		30 A	TSC 2634	65 A	TSC 3634
	48 VDC (45...55 VDC)	1 A	TSC 2039	3.6 A	TSC 1239
		2.7 A	TSC 3039	7.3 A	TSC 1339
		4.5 A	TSC 5039	11 A	TSC 1539
		6.5 A	TSC 0639	14 A	TSC 3539
		9 A	TSC 6039	23 A	TSC 3739
		15 A	TSC 2639	30 A	TSC 3639
110 VDC (100...130 VDC)	0.5 A	TSC 2037	1.5 A	TSC 1237	
	1.2 A	TSC 3037	3 A	TSC 1337	
	2 A	TSC 5037	4.5 A	TSC 1537	
	3 A	TSC 0637	6.5 A	TSC 3537	
	4 A	TSC 6037	10 A	TSC 3737	
	6.5 A	TSC 2637	14 A	TSC 3637	
220 VDC (200...250 VDC)	0.25 A	TSC 2038	0.8 A	TSC 1238	
	0.6 A	TSC 3038	1.5 A	TSC 1338	
	1 A	TSC 5038	2.4 A	TSC 1538	
	1.5 A	TSC 0638	3.5 A	TSC 3538	
	2 A	TSC 6038	5 A	TSC 3738	
	3.2 A	TSC 2638	7 A	TSC 3638	
			10 A	TSC 3838	

Other output voltages on request

Height: 1U = 44.45 mm (1.75")

All specifications valid at nominal input voltage, full load and +25°C after warm-up time unless otherwise stated.

Models					
		3U Height Modules		6U Height Modules	
Input voltage range	Output voltage (adjust. range)	Output current max.	Order code	Output current max.	Order code
80...160 VDC	5 VDC (4.5...5.5 VDC)	8 A	TSC 2050	30 A	TSC 1250
		20 A	TSC 3050	50 A	TSC 1350
		35 A	TSC 5050	80 A	TSC 1550
		50 A	TSC 0650	110 A	TSC 3550
		80 A	TSC 6050	165 A	TSC 3750
		100 A	TSC 2650	220 A	TSC 3650
	12 VDC (11...13 VDC)	4 A	TSC 2052	15 A	TSC 1252
		12 A	TSC 3052	30 A	TSC 1352
		20 A	TSC 5052	42 A	TSC 1552
		26 A	TSC 0652	56 A	TSC 3552
		40 A	TSC 6052	85 A	TSC 3752
		60 A	TSC 2652	115 A	TSC 3652
	24 VDC (23...26 VDC)	2 A	TSC 2054	7.5 A	TSC 1254
		6 A	TSC 3054	15 A	TSC 1354
		10 A	TSC 5054	23 A	TSC 1554
		14 A	TSC 0654	30 A	TSC 3554
		20 A	TSC 6054	50 A	TSC 3754
		30 A	TSC 2654	65 A	TSC 3654
	48 VDC (45...55 VDC)	1 A	TSC 2059	3.6 A	TSC 1259
		2.7 A	TSC 3059	7.3 A	TSC 1359
		4.5 A	TSC 5059	11 A	TSC 1559
		6.5 A	TSC 0659	14 A	TSC 3559
		9 A	TSC 6059	23 A	TSC 3759
		15 A	TSC 2659	30 A	TSC 3659
110 VDC (100...130 VDC)	0.5 A	TSC 2057	1.5 A	TSC 1257	
	1.2 A	TSC 3057	3 A	TSC 1357	
	2 A	TSC 5057	4.5 A	TSC 1557	
	3 A	TSC 0657	6.5 A	TSC 3557	
	4 A	TSC 6057	10 A	TSC 3757	
	6.5 A	TSC 2657	14 A	TSC 3657	
220 VDC (200...250 VDC)	0.25A	TSC 2058	0.8 A	TSC 1258	
	0.6 A	TSC 3058	1.5 A	TSC 1358	
	1 A	TSC 5058	2.4 A	TSC 1558	
	1.5 A	TSC 0658	3.5 A	TSC 3558	
	2 A	TSC 6058	5 A	TSC 3758	
	3.2 A	TSC 2658	7 A	TSC 3658	
			10 A	TSC 3858	

Other output voltages on request

Height: 1U = 44.45 mm (1.75")

All specifications valid at nominal input voltage, full load and +25°C after warm-up time unless otherwise stated.

Models					
		3U Height Modules		6U Height Modules	
Input voltage range	Output voltage (adjust. range)	Output current max.	Order code	Output current max.	Order code
160...320 VDC	5 VDC (4.5...5.5 VDC)	8 A	TSC 2070	30 A	TSC 1270
		20 A	TSC 3070	50 A	TSC 1370
		35 A	TSC 5070	80 A	TSC 1570
		50 A	TSC 0670	110 A	TSC 3570
		80 A	TSC 6070	165 A	TSC 3770
		100 A	TSC 2670	220 A	TSC 3670
	12 VDC (11...13 VDC)	4 A	TSC 2072	15 A	TSC 1272
		12 A	TSC 3072	30 A	TSC 1372
		20 A	TSC 5072	42 A	TSC 1572
		26 A	TSC 0672	56 A	TSC 3572
		40 A	TSC 6072	85 A	TSC 3772
		60 A	TSC 2672	115 A	TSC 3672
	24 VDC (23...26 VDC)	2 A	TSC 2074	7.5 A	TSC 1274
		6 A	TSC 3074	15 A	TSC 1374
		10 A	TSC 5074	23 A	TSC 1574
		14 A	TSC 0674	30 A	TSC 3574
		20 A	TSC 6074	50 A	TSC 3774
		30 A	TSC 2674	65 A	TSC 3674
	48 VDC (45...55 VDC)	1 A	TSC 2079	3.6 A	TSC 1279
		2.7 A	TSC 3079	7.3 A	TSC 1379
		4.5 A	TSC 5079	11 A	TSC 1579
		6.5 A	TSC 0679	14 A	TSC 3579
		9 A	TSC 6079	23 A	TSC 3779
		15 A	TSC 2679	30 A	TSC 3679
110 VDC (100...130 VDC)	0.5 A	TSC 2077	1.5 A	TSC 1277	
	1.2 A	TSC 3077	3 A	TSC 1377	
	2 A	TSC 5077	4.5 A	TSC 1577	
	3 A	TSC 0677	6.5 A	TSC 3577	
	4 A	TSC 6077	10 A	TSC 3777	
	6.5 A	TSC 2677	14 A	TSC 3677	
220 VDC (200...250 VDC)	0.25A	TSC 2078	0.8 A	TSC 1278	
	0.6 A	TSC 3078	1.5 A	TSC 1378	
	1 A	TSC 5078	2.4 A	TSC 1578	
	1.5 A	TSC 0678	3.5 A	TSC 3578	
	2 A	TSC 6078	5 A	TSC 3778	
	3.2 A	TSC 2678	7 A	TSC 3678	
			10 A	TSC 3878	

Other output voltages on request

Height: 1U = 44.45 mm (1.75")

All specifications valid at nominal input voltage, full load and +25°C after warm-up time unless otherwise stated.

Models with AC - Input					
Input voltage range	Output voltage (adjust. range)	3U Height Modules		6U Height Modules	
		Output current max.	Order code	Output current max.	Order code
93...138 VAC / 185...264 VAC (selectable) 50 / 60 Hz	5 VDC (4.5...5.5 VDC)	8 A	TSC 2090	30 A	TSC 1290
		20 A	TSC 3090	50 A	TSC 1390
		35 A	TSC 5090	80 A	TSC 1590
		50 A	TSC 0690	110 A	TSC 3590
		80 A	TSC 6090	165 A	TSC 3790
		100 A	TSC 2690	220 A	TSC 3690
	12 VDC (11...13 VDC)	4 A	TSC 2092	15 A	TSC 1292
		12 A	TSC 3092	30 A	TSC 1392
		20 A	TSC 5092	42 A	TSC 1592
		26 A	TSC 0692	56 A	TSC 3592
		40 A	TSC 6092	85 A	TSC 3792
		60 A	TSC 2692	115 A	TSC 3692
	24 VDC (23...26 VDC)	2 A	TSC 2094	7.5 A	TSC 1294
		6 A	TSC 3094	15 A	TSC 1394
		10 A	TSC 5094	23 A	TSC 1594
		14 A	TSC 0694	30 A	TSC 3594
		20 A	TSC 6094	50 A	TSC 3794
		30 A	TSC 2694	65 A	TSC 3694
	48 VDC (45...55 VDC)	1 A	TSC 2099	3.6 A	TSC 1299
		2.7 A	TSC 3099	7.3 A	TSC 1399
		4.5 A	TSC 5099	11 A	TSC 1599
		6.5 A	TSC 0699	14 A	TSC 3599
		9 A	TSC 6099	23 A	TSC 3799
		15 A	TSC 2699	30 A	TSC 3699
110 VDC (100...130 VDC)	0.5 A	TSC 2097	1.5 A	TSC 1297	
	1.2 A	TSC 3097	3 A	TSC 1397	
	2 A	TSC 5097	4.5 A	TSC 1597	
	3 A	TSC 0697	6.5 A	TSC 3597	
	4 A	TSC 6097	10 A	TSC 3797	
	6.5 A	TSC 2697	14 A	TSC 3697	
220 VDC (200...250 VDC)	0.25A	TSC 2098	0.8 A	TSC 1298	
	0.6 A	TSC 3098	1.5 A	TSC 1398	
	1 A	TSC 5098	2.4 A	TSC 1598	
	1.5 A	TSC 0698	3.5 A	TSC 3598	
	2 A	TSC 6098	5 A	TSC 3798	
	3.2 A	TSC 2698	7 A	TSC 3698	
			10 A	TSC 3898	

Other output voltages on request

Height: 1U = 44.45 mm (1.75")

All specifications valid at nominal input voltage, full load and +25°C after warm-up time unless otherwise stated.

Input Specifications

Inrush current		20 x I _{out} nom. typ.
Inrush current limiting	AC Input DC Input	Standard with option "i"
Input current at no load		3% full load typ.
Max ripple of dc input voltage		10% pk-pk
Start-up delay time		100 ms typ. (softstart)
Hold-up time	230VAC Input 115VAC Input	15 ms typ. 7 ms typ.

Output Specifications

Output voltage range		adjustable (refer to model selection table)
Regulation	- Input variation ± 10 % - Load variation 10 – 90 %:	± 0.1 % max. ± 0.2 % max.
Ripple and noise (20 MHz Bandwidth)		< 1% V _{out} +30 mVpk-pk max.
Transient response to ± 1%		2 ms
Dynamic response		6% typ.
Output current limitation		105 – 110% of I _{out} max.
Short circuit protection		constant current, automatic recovery
Overvoltage protection		105% of V _{out} max
Remote sense		standard for all models

General Specifications

Ambient temperature ranges	- Operating - (optional) - Storage	- 20 °C ... +75 °C - 40 °C ... +75 °C - 40 °C ... +85 °C
Derating above 55°C		2.5% /°C
Temperature coefficient		0.02% / °C typ.
Efficiency	Models with 5VDC output: Other models:	70% typ. 85% typ.
Switching frequency		33 KHz typ.
Isolation voltage	Models with input voltage < 75 VDC: - Input / Output - Input / Case - Output / Case Models with input voltage > 80 VDC and AC models: - Input / Output - Input / Case - Output / Case	1'500 VDC 1'500 VDC 1'000 VDC 3'000 VDC 3'000 VDC 1'000 VDC

All specifications valid at nominal input voltage, full load and +25°C after warm-up time unless otherwise stated.

General Specifications

Isolation resistance	– Input/Output (500VDC)	> 10 M Ohm
Reliability (MIL-HDBK-217 E)		> 100'000 h @ 40°C
Safety standards		IEC/EN 60950
Electromagnetic compatibility (EMC), Emission	– Conducted RI suppression on input	EN 55022, class A (class B on request)
Electromagnetic compatibility (EMC), Immunity	– Electrical fast transients / burst immunity – Surge immunity	IEC/EN 61000-4-4, 2kV IEC/EN 61000-4-5, 2kV
Connection		H15 male connector (DIN 41612) (screw terminal for output current >50A)

Alarm Options

Power fail	Option "p"	Signal if input voltage drops below the specified limit. Signal output is NPN open collector, activated in ok-status
DC- ok	Option "d"	Signal if output voltage drops below the specified limit Signal output is NPN open collector, activated in ok-status
Relay output	Option "r"	Relay instead of logical output for alarm signals. (in combination with option "p" and "d")

Control Options

External On/OFF	Option "h"	Connection to negative input line inactivates the unit
System reset	Option "y"	Reset input specified for VME systems
External programming	Option "e"	External programming of the output voltage by a potentiometer or an external voltage of 0VDC to 10VDC. Details need to be specified.

I/O Options

Current sharing	Option "cs"	Provides balanced load for units in parallel operation. Controlled over interconnecting wire.
Decoupling diode	Option "dd"	For redundant operation. Internal fault of one unit does not affect other units in a parallel circuit .
Inrush current limiting	Option "i"	A thermistor in series to the input lines reduces its resistance when it gets warm.

Mechanical Options

Wall mounting	Option "w"	Module is screwed on a mounting plate for install in a cabinet This option includes screw terminal block for connection
Mechanical strength	Option "ms"	Rugged construction for harsh environment.
Extended temperature range	Option "c"	The unit is designed and tested for operation at an ambient temperature range of -40...+75°C

Further options and combinations on request!

All specifications valid at nominal input voltage, full load and +25°C after warm-up time unless otherwise stated.

Outline Dimensions mm (inches)

TSC 2000

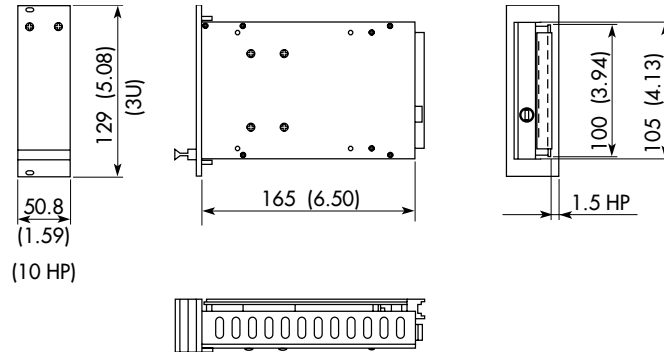

weight:
0.9kg (2 lb)

TSC 3000

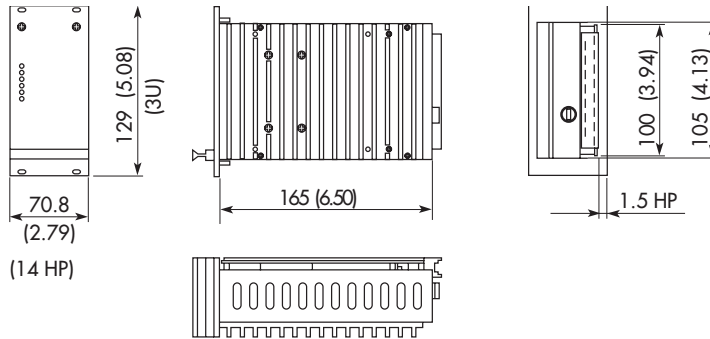

weight:
1kg (2.2 lb)

TSC 5000

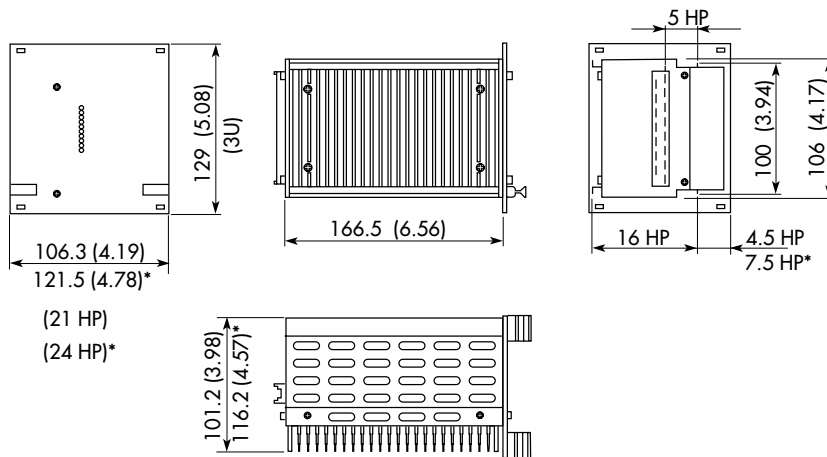

weight:
1.7kg (3.8lb)
2.1kg (4.6lb)*

* 5 VDC output units

1 U = 44.45mm (1.75") 1 HP = 5,08mm (0.2")

Specifications can be changed without notice

Outline Dimensions mm (inches)

**TSC 600
TSC 6000**

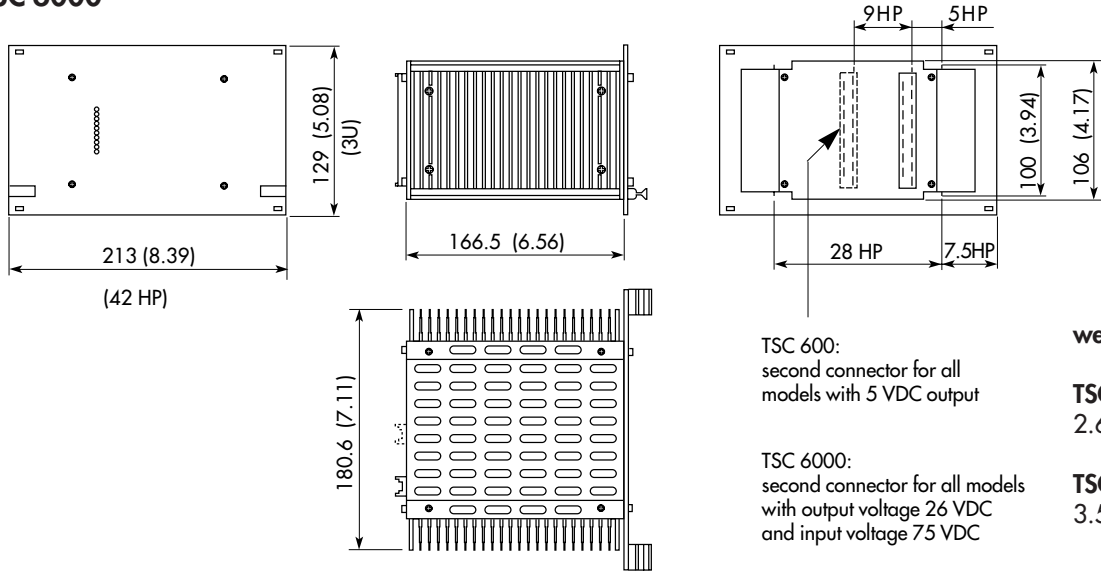

TSC 600:
second connector for all
models with 5 VDC output

weight:

TSC 600
2.6kg (5.7 lb)

TSC 6000:
second connector for all models
with output voltage 26 VDC
and input voltage 75 VDC

TSC 6000
3.5kg (7.7lb)

TSC 2600

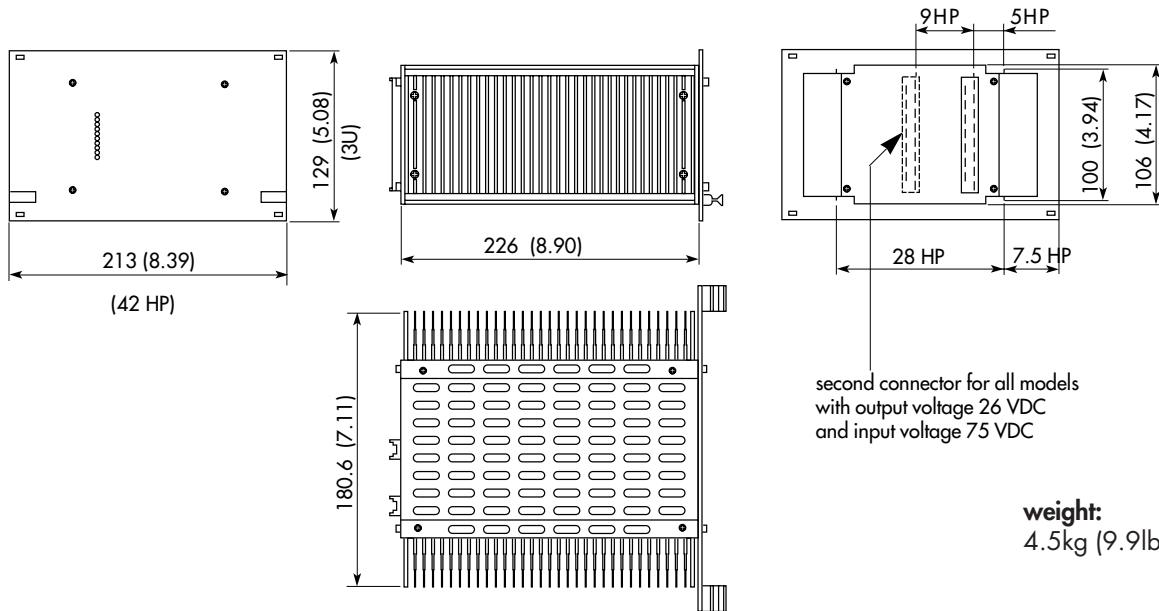

second connector for all models
with output voltage 26 VDC
and input voltage 75 VDC

weight:

4.5kg (9.9lb)

1 U = 44.45mm (1.75") 1 HP = 5,08mm (0.2")

Specifications can be changed without notice

Outline Dimensions mm (inches)

TSC 1200

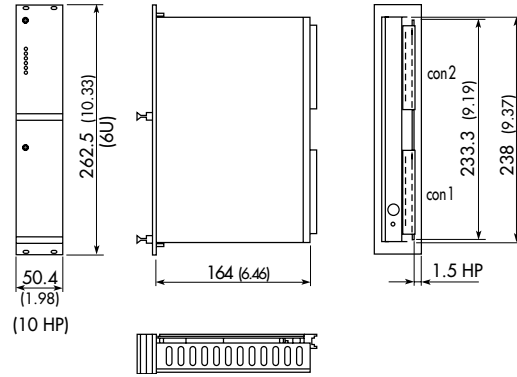

weight:
1.7kg (3.8lb)

TSC 1300

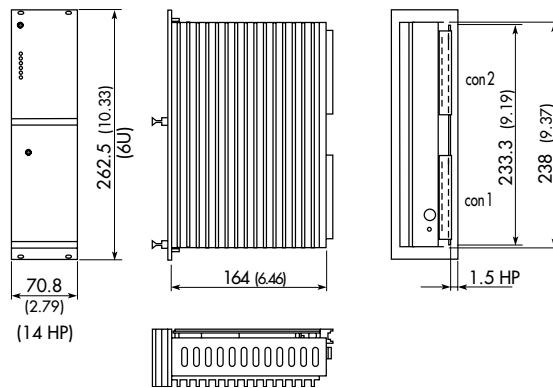

weight:
2.0kg (4.4lb)

TSC 1500

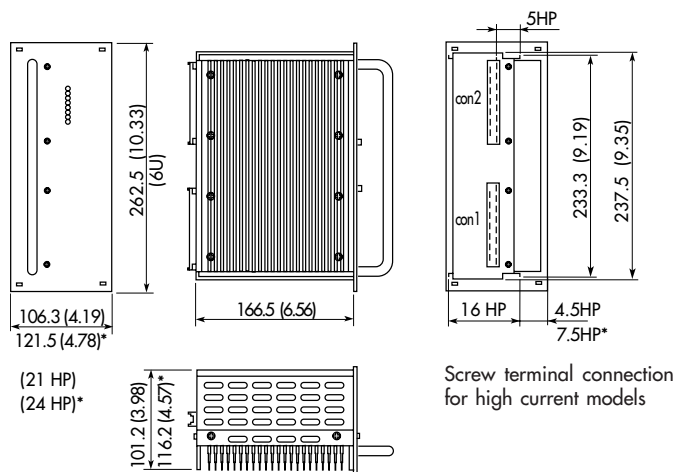

weight:
3.0kg (6.6lb)
3.7kg (8.1lb)*

* 5 VDC output units

1 U = 44.45mm (1.75") 1 HP = 5,08mm (0.2")

Specifications can be changed without notice

Outline Dimensions mm (inches)

TSC 3500

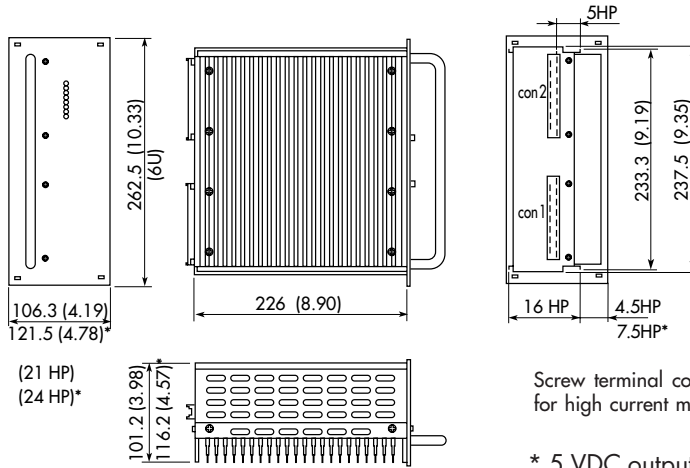

Screw terminal connection
for high current models
* 5 VDC output units

weight:
5.0kg (11.0lb)
6.2kg (13.6lb)*

TSC 3700

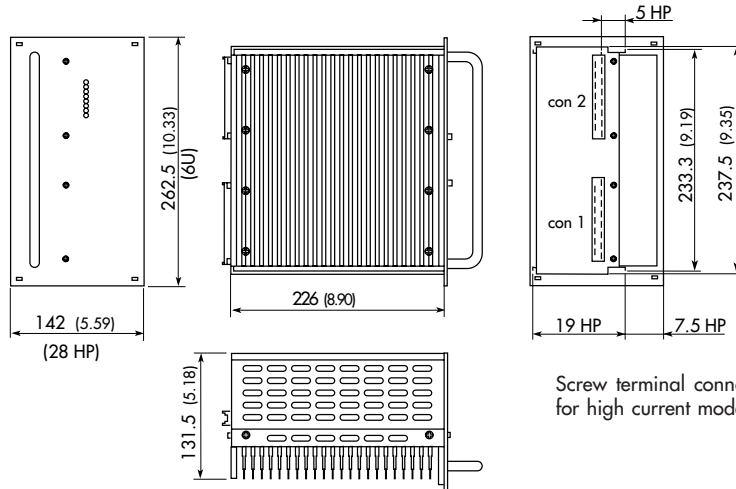

Screw terminal connection
for high current models

weight:
6.5kg (14.3lb)

TSC 3600

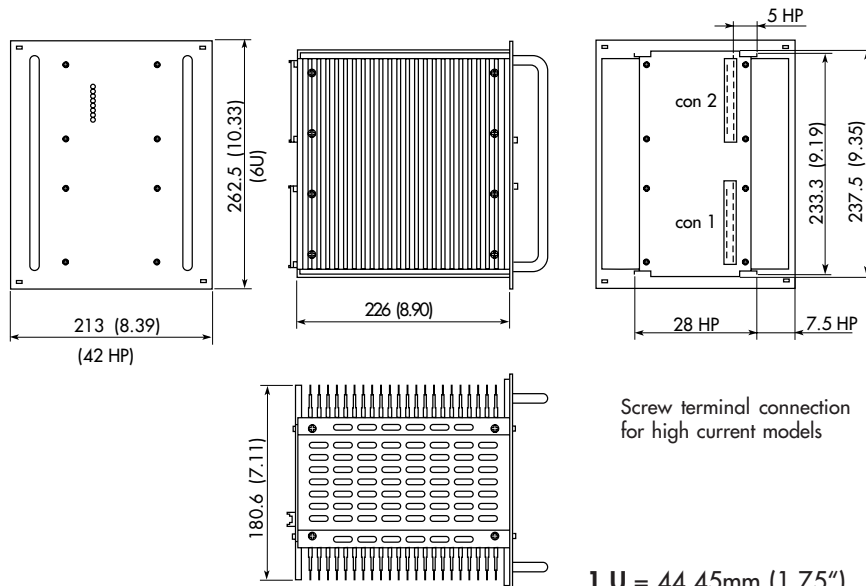

Screw terminal connection
for high current models

weight:
10kg (22lb)

1 U = 44.45mm (1.75") 1 HP = 5,08mm (0.2")

Specifications can be changed without notice

Outline Dimensions mm (inches)

TSC 3800

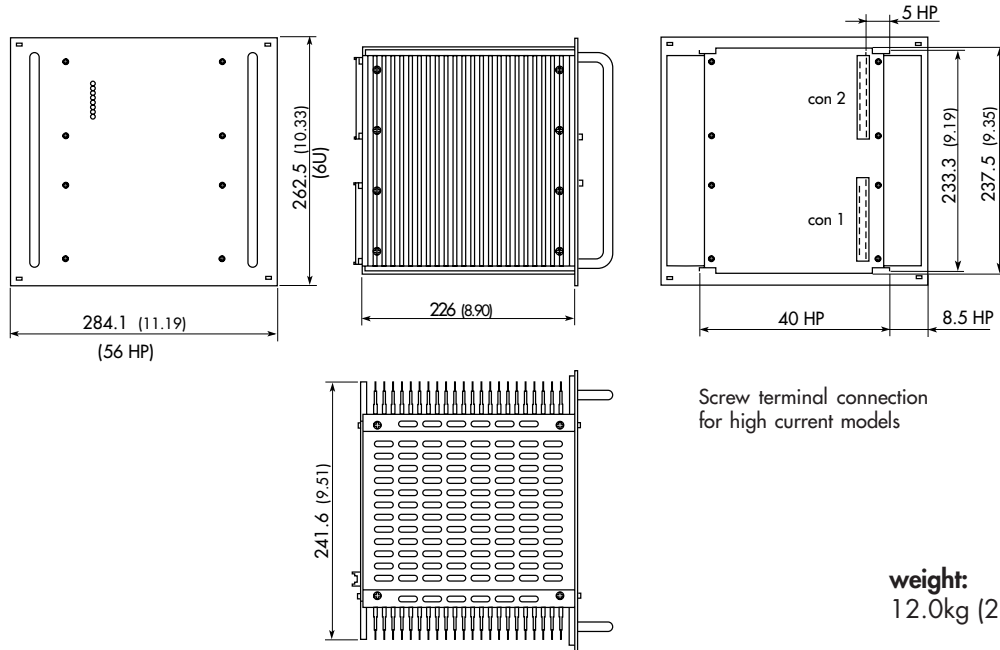

Screw terminal connection
for high current models

weight:
12.0kg (2.6 lb)

1 U = 44.45mm (1.75") 1 HP = 5,08mm (0.2")

Specifications can be changed without notice