

# MAXIM

## 660ns $\mu$ P-Compatible, 8-Bit ADC with Track/Hold

**MX7821**

### General Description

The MX7821 high-speed, microprocessor-compatible ( $\mu$ P), 8-bit analog-to-digital converter (ADC) is a plug-in upgrade for the industry-standard 7820. The MX7821 uses a half-flash technique, resulting in a 660ns conversion time vs. 1.36 $\mu$ s for the 7820. A VSS pin, not supplied by the 7820, supports dual power supplies and bipolar analog inputs.

The MX7821 has track-and-hold function capable of digitizing a 100kHz signal, and is tested for both its static and dynamic capability. The converter- $\mu$ P interface appears as a memory location or input/output port that requires no external interface logic. The data outputs use latched, three-state buffered circuitry for direct connection to a  $\mu$ P data bus or system input port. The MX7821 has an overflow output for cascading devices to attain higher resolution. The ADC's input/reference arrangement enables ratiometric operation. For a detailed description of MX7821 operation, refer to the MX7820 data sheet.

### Applications

Digital-Signal Processing  
High-Speed Data Acquisition  
Telecommunications  
High-Speed Servo Loops  
Audio Systems

### Functional Diagram

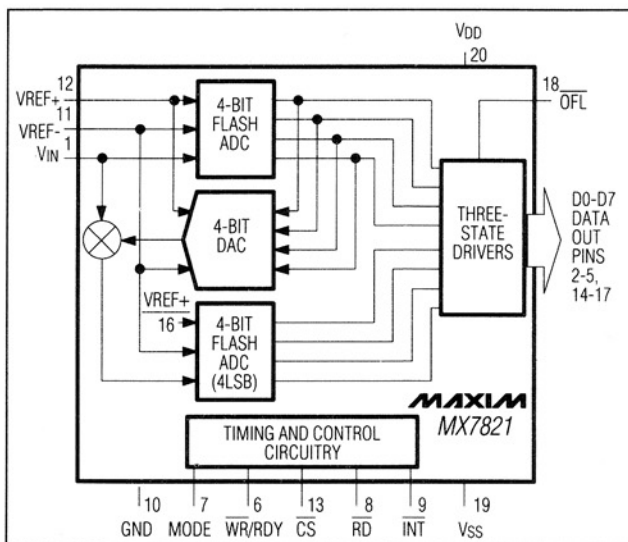

### Features

- ◆ 660ns Conversion Time
- ◆ 20-Pin Narrow DIP Package
- ◆ No External Clock
- ◆ Pin-Compatible Upgrade for Industry-Standard 7820
- ◆ 100kHz Input Signal Bandwidth
- ◆ Bipolar/Unipolar Inputs
- ◆ Single +5V or Dual  $\pm$ 5V Supplies
- ◆ Ratiometric Reference Inputs
- ◆ Static and Dynamic Tested
- ◆ Internal Track/Hold

### Ordering Information

PART	TEMP. RANGE	PIN-PACKAGE
MX7821KN	0°C to +70°C	20 Plastic DIP
MX7821KR	0°C to +70°C	20 Wide SO
MX7821KP	0°C to +70°C	20 PLCC
MX7821K/D	0°C to +70°C	Dice*
MX7821BQ	-40°C to +85°C	20 CERDIP
MX7821KEWP	-40°C to +85°C	20 Wide SO
MX7821TE	-55°C to +125°C	20 LCC**
MX7821TQ	-55°C to +125°C	20 CERDIP**

\* Contact factory for dice specifications.

\*\* Contact factory for availability and processing to MIL-STD-883.

### Pin Configurations

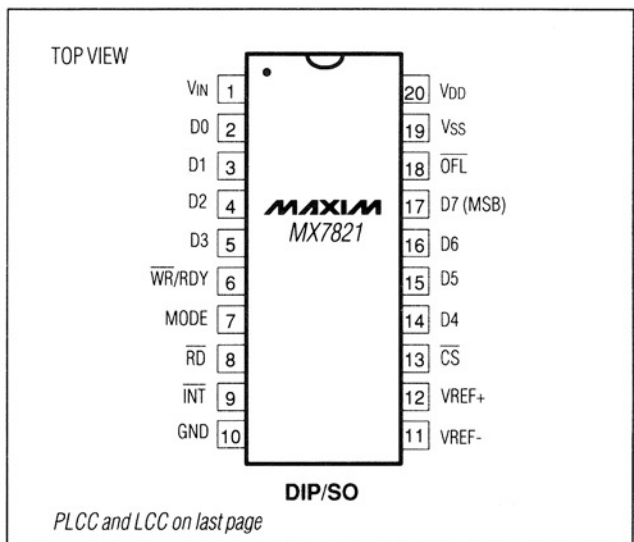
**MAXIM**

Maxim Integrated Products 1

For pricing, delivery, and ordering information, please contact Maxim/Dallas Direct! at 1-888-629-4642, or visit Maxim's website at [www.maxim-ic.com](http://www.maxim-ic.com).

# 660ns $\mu$ P-Compatible, 8-Bit ADC with Track/Hold

## ABSOLUTE MAXIMUM RATINGS

V <sub>DD</sub> to GND	-0.3V to +7V
V <sub>SS</sub> to GND	+0.3V to -7V
Digital Output Voltage to GND (Pins 2-5, 9, 14-16, 18)	-0.3V to V <sub>DD</sub> +0.3V
V <sub>REF+</sub> to AGND	V <sub>SS</sub> -0.3V to V <sub>DD</sub> +0.3V
V <sub>REF-</sub> to AGND	V <sub>SS</sub> -0.3V to V <sub>DD</sub> +0.3V
V <sub>IN</sub> to GND	V <sub>SS</sub> -0.3V to V <sub>DD</sub> +0.3V
Continuous Power Dissipation (any package) to +75°C	1000mW
derate above +75°C by	10mW/°C

Operating Temperature Ranges:	
MX7821K	0°C to +70°C
MX7821B	-40°C to +85°C
MX7821T	-55°C to +125°C
Storage Temperature Range	-65°C to +150°C
Lead Temperature (soldering, 10 sec)	+300°C

Stresses beyond those listed under "Absolute Maximum Ratings" may cause permanent damage to the device. These are stress ratings only, and functional operation of the device at these or any other conditions beyond those indicated in the operational sections of the specifications is not implied. Exposure to absolute maximum rating conditions for extended periods may affect device reliability.

## ELECTRICAL CHARACTERISTICS

(V<sub>DD</sub> = +5V  $\pm$ 5%; GND = 0V; Unipolar Input Range: V<sub>SS</sub> = 0V, V<sub>REF+</sub> = 5V, V<sub>REF-</sub> = 0V; Bipolar Input Range: V<sub>SS</sub> = -5V  $\pm$ 5%, V<sub>REF+</sub> = 2.5V, V<sub>REF-</sub> = -2.5V; specifications apply for RD mode, Pin 7 = 0V; T<sub>A</sub> = T<sub>MIN</sub> to T<sub>MAX</sub>, unless otherwise noted.) (Note 1)

PARAMETER	SYMBOL	CONDITIONS	MIN	TYP	MAX	UNITS
<b>UNIPOLAR INPUT RANGE</b>						
Resolution	N		8			Bits
Total Unadjusted Error (Note 2)	TUE				$\pm 1$	LSB
No Missing Codes Resolution			8			Bits
<b>BIPOLAR INPUT RANGE</b>						
Resolution	N		8			Bits
Zero-Code Error					$\pm 1$	LSB
Full-Scale Error					$\pm 1$	LSB
Signal-to-Noise Ratio	SNR	V <sub>IN</sub> = 99.85kHz full-scale sine wave with f <sub>SAMPLING</sub> = 500kHz	45			dB
Total Harmonic Distortion	THD	V <sub>IN</sub> = 99.85kHz full-scale sine wave with f <sub>SAMPLING</sub> = 500kHz			-50	dB
Peak Harmonic or Spurious Noise		V <sub>IN</sub> = 99.85kHz full-scale sine wave with f <sub>SAMPLING</sub> = 500kHz			-50	dB
Intermodulation Distortion	IMD	f <sub>a</sub> (84.72kHz) and f <sub>b</sub> (94.97kHz) full-scale sine waves with f <sub>SAMPLING</sub> = 500kHz	2nd-order terms		-50	dB
			3rd-order terms		-50	
Slew Rate, Tracking				2.36	1.6	V/ $\mu$ s
<b>REFERENCE INPUT</b>						
Input Resistance		Resistance between V <sub>REF+</sub> and V <sub>REF-</sub>	1		4	k $\Omega$
V <sub>REF+</sub> Input Range			V <sub>REF-</sub>		V <sub>DD</sub>	V
V <sub>REF-</sub> Input Range			V <sub>SS</sub>		V <sub>REF+</sub>	V
<b>ANALOG INPUT</b>						
Input Voltage Range			V <sub>REF-</sub>		V <sub>REF+</sub>	V
Input Leakage Current		-5V $\leq$ V <sub>IN</sub> $\leq$ 5V			$\pm 3$	$\mu$ A
Input Capacitance	C <sub>IN</sub>			32		pF



# 660ns $\mu$ P-Compatible, 8-Bit ADC with Track/Hold

MX7821

## ELECTRICAL CHARACTERISTICS (continued)

( $V_{DD} = +5V \pm 5\%$ ;  $GND = 0V$ ; Unipolar Input Range:  $V_{SS} = 0V$ ,  $V_{REF+} = 5V$ ,  $V_{REF-} = 0V$ ; Bipolar Input Range:  $V_{SS} = -5V \pm 5\%$ ,  $V_{REF+} = 2.5V$ ,  $V_{REF-} = -2.5V$ ; specifications apply for RD mode, Pin 7 = 0V;  $T_A = T_{MIN}$  to  $T_{MAX}$ , unless otherwise noted.) (Note 1)

PARAMETER	SYMBOL	CONDITIONS	MIN	TYP	MAX	UNITS
<b>LOGIC INPUTS</b>						
Input High Voltage	$V_{INH}$	$\overline{CS}$ , $\overline{WR}$ , $\overline{RD}$	2.4			V
		MODE	3.5			
Input Low Voltage	$V_{INL}$	$\overline{CS}$ , $\overline{WR}$ , $\overline{RD}$			0.8	V
		MODE			1.5	
Input High Current	$I_{INH}$	$\overline{CS}$ , $\overline{RD}$			1	$\mu$ A
		$\overline{WR}$			3	
		MODE	50	200		
Input Low Current	$I_{INL}$				-1	$\mu$ A
Input Capacitance (Note 3)	$C_{IN}$		5		8	pF
<b>LOGIC OUTPUTS</b>						
Output Low Voltage	$V_{OL}$	D7–D0, $\overline{INT}$ , $\overline{OFL}$ ; $I_{SINK} = 1.6mA$			0.4	V
		RDY; $I_{SINK} = 2.6mA$			0.4	
Output High Voltage	$V_{OH}$	D7–D0, $\overline{INT}$ , $\overline{OFL}$ ; $I_{SOURCE} = -360\mu A$	4.0			V
Floating State Leakage Current	$I_{LKG}$	D7–D0, RDY			$\pm 3$	$\mu$ A
Floating State Output Capacitance (Note 3)	$C_{OUT}$	D7–D0, RDY	5		8	pF
<b>POWER REQUIREMENTS</b>						
Supply Current	$I_{DD}$	CS = RD = 0V	MX7821K		15	mA
			MAX7821B/T		20	
	$I_{SS}$				100	$\mu$ A
Power Dissipation	$P_D$		50			mW
Power-Supply Sensitivity	PSR	$V_{DD} = 4.75V$ to $5.25V$ , $V_{REF+} = 4.75V$ MAX for unipolar mode	$\pm 1/16$	$\pm 1/4$		LSB

**Note 1:** Performance over power-supply tolerance guaranteed by power-supply rejection test.

**Note 2:** Total Unadjusted Error includes relative accuracy, zero-code error, and full-scale error.

**Note 3:** Guaranteed by design.

## TIMING CHARACTERISTICS

( $V_{DD} = +5V$ ,  $V_{SS} = 0V$  or  $-5V$ , Unipolar or Bipolar Input Range,  $T_A = +25^\circ C$ , unless otherwise noted.)

PARAMETER	SYMBOL	CONDITIONS	MIN	TYP	MAX	UNITS
$\overline{CS}$ to $\overline{RD}/\overline{WR}$ Setup Time	$t_{CSS}$		0			ns
$\overline{CS}$ to $\overline{RD}/\overline{WR}$ Hold Time	$t_{CSH}$		0			ns
$\overline{CS}$ to RDY Delay (Note 4)	$t_{RDY}$	$T_A = +25^\circ C$			70	ns
		$T_A = T_{MIN}$ to $T_{MAX}$	MX7821B/K		85	
			MX7821T		100	
Conversion Time (RD Mode)	$t_{CRD}$	$T_A = +25^\circ C$			700	ns
		$T_A = T_{MIN}$ to $T_{MAX}$	MX7821B/K		875	
			MX7821T		975	

# 660ns $\mu$ P-Compatible, 8-Bit ADC with Track/Hold

**MX7821**

## TIMING CHARACTERISTICS (continued)

( $V_{DD} = +5V$ ,  $V_{SS} = 0V$  or  $-5V$ , Unipolar or Bipolar Input Range,  $T_A = +25^\circ C$ , unless otherwise noted.)

PARAMETER	SYMBOL	CONDITIONS	MIN	TYP	MAX	UNITS	
Data-Access Time (RD Mode) (Note 5)	$t_{ACC0}$	$T_A = +25^\circ C$ , $C_L = 20pF$			$t_{CRD}+25$	ns	
		$T_A = T_{MIN}$ to $T_{MAX}$ , $C_L = 20pF$	MX7821B/K		$t_{CRD}+30$		
			MX7821T		$t_{CRD}+35$		
		$T_A = +25^\circ C$ , $C_L = 100pF$			$t_{CRD}+50$		
		$T_A = T_{MIN}$ to $T_{MAX}$ , $C_L = 100pF$	MX7821B/K		$t_{CRD}+65$		
MX7821T			$t_{CRD}+75$				
$\overline{RD}$ to $\overline{INT}$ Delay (RD Mode)	$t_{INTH}$	$T_A = +25^\circ C$ , $C_L = 50pF$		50	80	ns	
		$T_A = T_{MIN}$ to $T_{MAX}$ , $C_L = 50pF$	MX7821B/K		85		
			MX7821T		90		
Data-Hold Time (Note 6)	$t_{DH}$	$T_A = +25^\circ C$			60	ns	
		$T_A = T_{MIN}$ to $T_{MAX}$	MX7821B/K		70		
			MX7821T		80		
Delay Time Between Conversions	$t_p$	$T_A = +25^\circ C$	350			ns	
		$T_A = T_{MIN}$ to $T_{MAX}$	MX7821B/K	425			
			MX7821T	500			
Write Pulse Width	$t_{WR}$	$T_A = +25^\circ C$	0.250		10	$\mu s$	
		$T_A = T_{MIN}$ to $T_{MAX}$	MX7821B/K	0.325			10
			MX7821T	0.400			10
Delay Time Between WR and RD Pulses	$t_{RD}$	$T_A = +25^\circ C$	250			ns	
		$T_A = T_{MIN}$ to $T_{MAX}$	MX7821B/K	350			
			MX7821T	450			
$\overline{RD}$ Pulse Width (WR-RD Mode) Determined by $t_{ACC1}$	$t_{READ1}$	$T_A = +25^\circ C$ (Figure 3)	160			ns	
		$T_A = T_{MIN}$ to $T_{MAX}$ (Figure 3)	MX7821B/K	205			
			MX7821T	240			
Data-Access Time (WR-RD Mode) (Note 5)	$t_{ACC1}$	$T_A = +25^\circ C$ , $C_L = 20pF$ (Figure 3) (Note 3)			160	ns	
		$T_A = T_{MIN}$ to $T_{MAX}$ , $C_L = 20pF$ (Figure 3) (Note 3)	MX7821B/K		205		
			MX7821T		240		
		$T_A = +25^\circ C$ , $C_L = 100pF$ (Figure 3)			185		
		$T_A = T_{MIN}$ to $T_{MAX}$ , $C_L = 100pF$ (Figure 3)	MX7821B/K		235		
MX7821T			275				
$\overline{RD}$ to $\overline{INT}$ Delay	$t_{RI}$	$T_A = +25^\circ C$			150	ns	
		$T_A = T_{MIN}$ to $T_{MAX}$	MX7821B/K		185		
			MX7821T		220		
$\overline{WR}$ to $\overline{INT}$ Delay	$t_{INTL}$	$T_A = +25^\circ C$ , $C_L = 50pF$		380	500	ns	
		$T_A = T_{MIN}$ to $T_{MAX}$ , $C_L = 50pF$	MX7821B/K		610		
			MX7821T		700		

# 660ns $\mu$ P-Compatible, 8-Bit ADC with Track/Hold

MX7821

## TIMING CHARACTERISTICS (continued)

( $V_{DD} = +5V$ ,  $V_{SS} = 0V$  or  $-5V$ , Unipolar or Bipolar Input Range,  $T_A = +25^\circ C$ , unless otherwise noted.)

PARAMETER	SYMBOL	CONDITIONS	MIN	TYP	MAX	UNITS
RD Pulse Width (WR-RD Mode) Determined by $t_{ACC2}$	$t_{READ2}$	$T_A = +25^\circ C$ (Figure 4)			65	ns
		$T_A = T_{MIN}$ to $T_{MAX}$ (Figure 4)	MX7821B/K		75	
			MX7821T		85	
Data-Access Time (WR-RD Mode) (Note 5)	$t_{ACC2}$	$T_A = +25^\circ C$ , $C_L = 20pF$ (Figure 4) (Note 3)			65	ns
		$T_A = T_{MIN}$ to $T_{MAX}$ , $C_L = 20pF$ (Note 3)	MX7821B/K		75	
			MX7821T		85	
		$T_A = +25^\circ C$ , $C_L = 100pF$ (Figure 4)			90	
		$T_A = T_{MIN}$ to $T_{MAX}$ , $C_L = 100pF$ (Figure 4)	MX7821B/K		110	
MX7821T			130			
WR to INT Delay (Stand-Alone Operation)	$t_{HWR}$	$T_A = +25^\circ C$ , $C_L = 50pF$			80	ns
		$T_A = T_{MIN}$ to $T_{MAX}$ , $C_L = 50pF$	MX7821B/K		100	
			MX7821T		120	
Data-Access Time After INT (Stand-Alone Operation) (Note 5)	$t_{ID}$	$T_A = +25^\circ C$ , $C_L = 20pF$ (Note 3)			30	ns
		$T_A = T_{MIN}$ to $T_{MAX}$ , $C_L = 20pF$ (Note 3)	MX7821B/K		35	
			MX7821T		40	
		$T_A = +25^\circ C$ , $C_L = 100pF$			45	
		$T_A = T_{MIN}$ to $T_{MAX}$ , $C_L = 100pF$	MX7821B/K		60	
MX7821T			70			

**Note 3:** Guaranteed by design.

**Note 4:**  $C_L = 50pF$  and  $R_L = 5k\Omega$  pull-up resistor.

**Note 5:** See Figure 1 for load circuit. Parameter defined as the time required for the output to cross  $+0.8V$  or  $+2.4V$ .

**Note 6:** See Figure 2 for load circuit. Parameter defined as the time required for data lines to change  $0.5V$ .

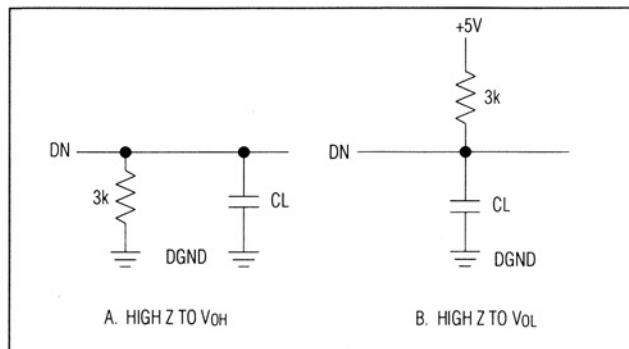

Figure 1. Load Circuits for Data-Access Time Test

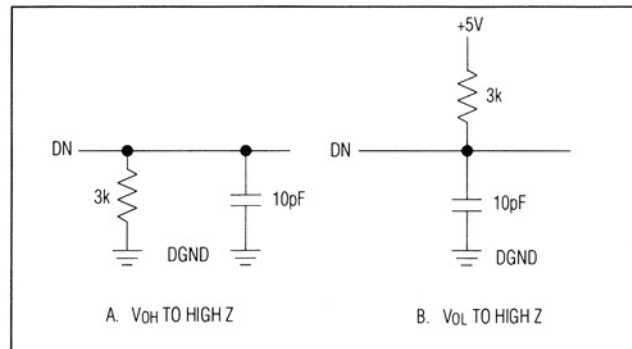

Figure 2. Load Circuits for Data-Hold Time Test



# 660ns $\mu$ P-Compatible, 8-Bit ADC with Track/Hold

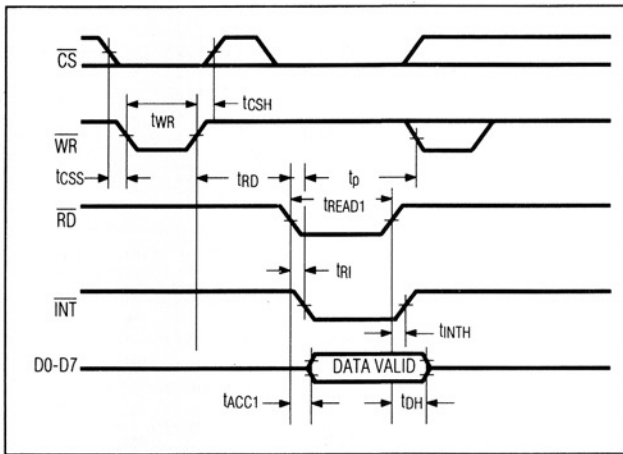

Figure 3. WR-RD Mode Timing ( $t_{RD} < t_{INTL}$ )

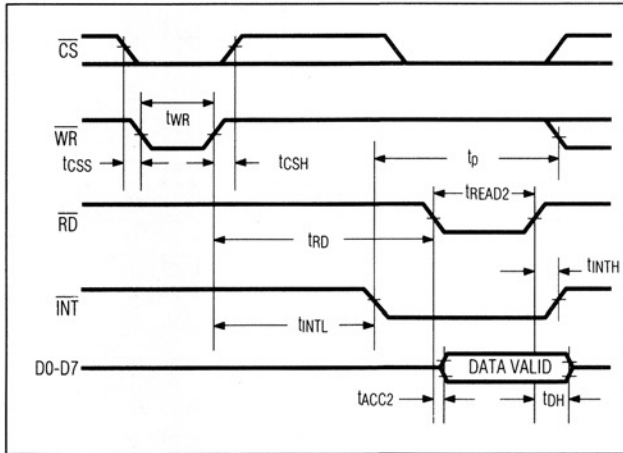

Figure 4. WR-RD Mode Timing ( $t_{RD} > t_{INTL}$ )

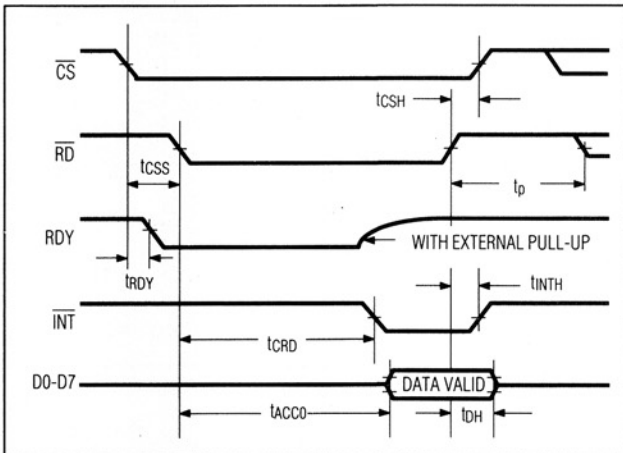

Figure 5. RD Mode

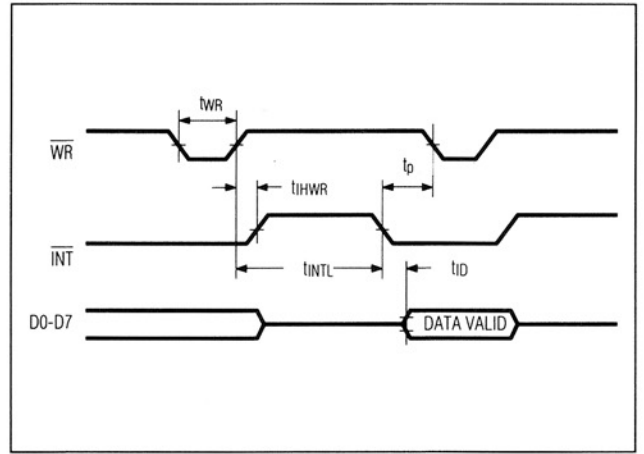
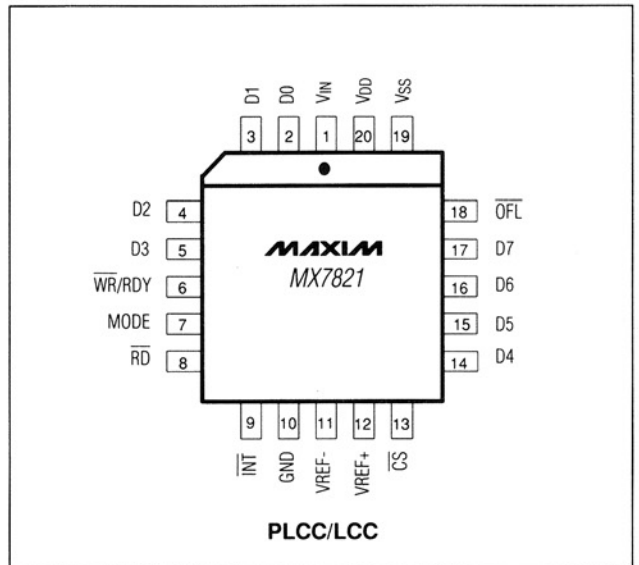

Figure 6. WR-RD Mode Stand-Alone Operation ( $\overline{CS} = \overline{RD} = 0$ )

## Pin Configurations (continued)



**For application information, refer to the MX7820 data sheet.**

# 660ns $\mu$ P-Compatible, 8-Bit ADC with Track/Hold

## Package Information

MX7821

(The package drawing(s) in this data sheet may not reflect the most current specifications. For the latest package outline information go to [www.maxim-ic.com/packages](http://www.maxim-ic.com/packages).)

**Plastic DIP  
PLASTIC  
DUAL-IN-LINE  
PACKAGE  
(0.300 in.)**

DIM	INCHES		MILLIMETERS	
	MIN	MAX	MIN	MAX
A	-	0.200	-	5.08
A1	0.015	-	0.38	-
A2	0.125	0.175	3.18	4.45
A3	0.055	0.080	1.40	2.03
B	0.016	0.022	0.41	0.56
B1	0.045	0.065	1.14	1.65
C	0.008	0.012	0.20	0.30
D1	0.005	0.080	0.13	2.03
E	0.300	0.325	7.62	8.26
E1	0.240	0.310	6.10	7.87
e	0.100	-	2.54	-
eA	0.300	-	7.62	-
eB	-	0.400	-	10.16
L	0.115	0.150	2.92	3.81

PKG.	DIM	PINS	INCHES		MILLIMETERS	
			MIN	MAX	MIN	MAX
P	D	8	0.348	0.390	8.84	9.91
P	D	14	0.735	0.765	18.67	19.43
P	D	16	0.745	0.765	18.92	19.43
P	D	18	0.885	0.915	22.48	23.24
P	D	20	1.015	1.045	25.78	26.54
N	D	24	1.14	1.265	28.96	32.13

21-0043A

**Wide SO  
SMALL-OUTLINE  
PACKAGE  
(0.300 in.)**

DIM	INCHES		MILLIMETERS	
	MIN	MAX	MIN	MAX
A	0.093	0.104	2.35	2.65
A1	0.004	0.012	0.10	0.30
B	0.014	0.019	0.35	0.49
C	0.009	0.013	0.23	0.32
E	0.291	0.299	7.40	7.60
e	0.050		1.27	
H	0.394	0.419	10.00	10.65
L	0.016	0.050	0.40	1.27

DIM	PINS	INCHES		MILLIMETERS	
		MIN	MAX	MIN	MAX
D	16	0.398	0.413	10.10	10.50
D	18	0.447	0.463	11.35	11.75
D	20	0.496	0.512	12.60	13.00
D	24	0.598	0.614	15.20	15.60
D	28	0.697	0.713	17.70	18.10

21-0042A

# 660ns $\mu$ P-Compatible, 8-Bit ADC with Track/Hold

**MX7821**

## Package Information (continued)

(The package drawing(s) in this data sheet may not reflect the most current specifications. For the latest package outline information go to [www.maxim-ic.com/packages](http://www.maxim-ic.com/packages).)

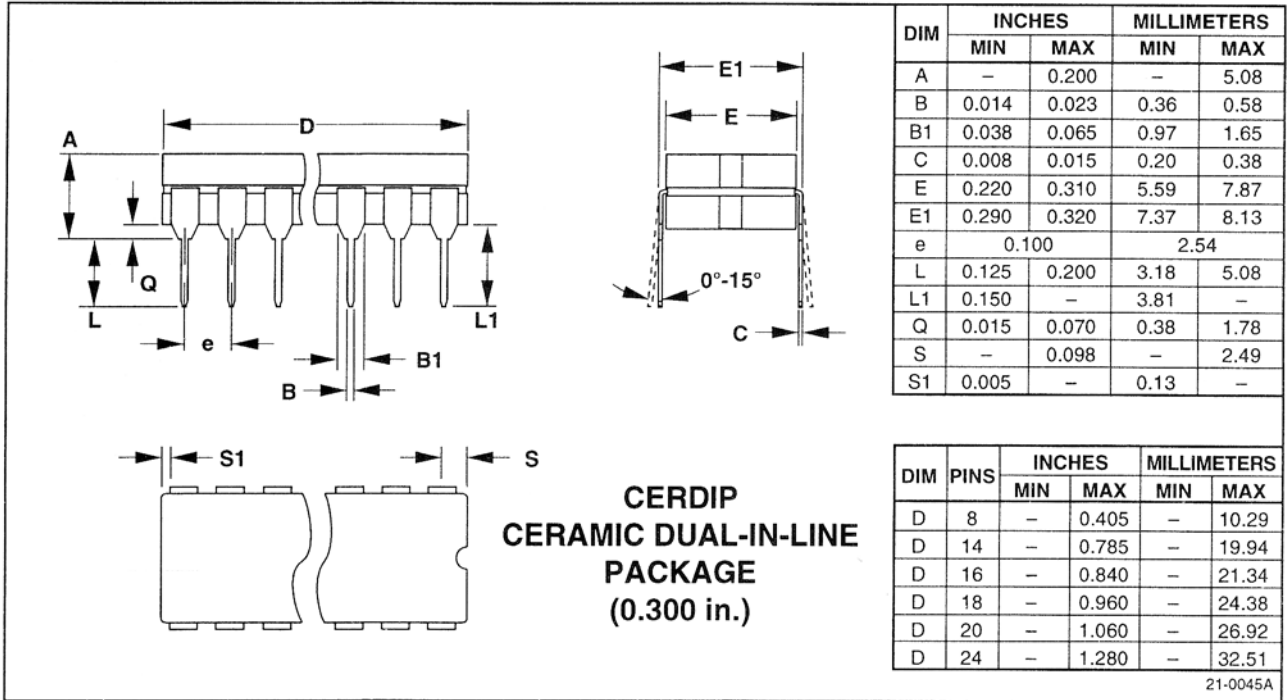

Maxim cannot assume responsibility for use of any circuitry other than circuitry entirely embodied in a Maxim product. No circuit patent licenses are implied. Maxim reserves the right to change the circuitry and specifications without notice at any time.

8 Maxim Integrated Products, 120 San Gabriel Drive, Sunnyvale, CA 94086 (408) 737-7600

© 1995 Maxim Integrated Products

Printed USA

MAXIM is a registered trademark of Maxim Integrated Products.