

TV SOUND CHANNEL

- HIGH SENSITIVITY
- EXCELLENT AM REJECTION
- DC VOLUME CONTROL
- PERITELEVISION FACILITY
- 4W OUTPUT POWER
- LOW DISTORTION
- THERMAL PROTECTION
- TURN-ON AND TURN-OFF MUTING

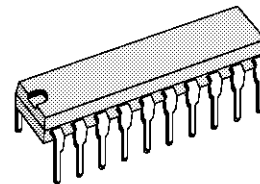

DIP20
(Plastic Package)

ORDER CODE : TDA8191

DESCRIPTION

The TDA8191 is a monolithic integrated circuit that includes all the functions needed for a complete TV sound channel. The TDA8191 is assembled in a 20 pin dual in line power package.

PIN CONNECTION

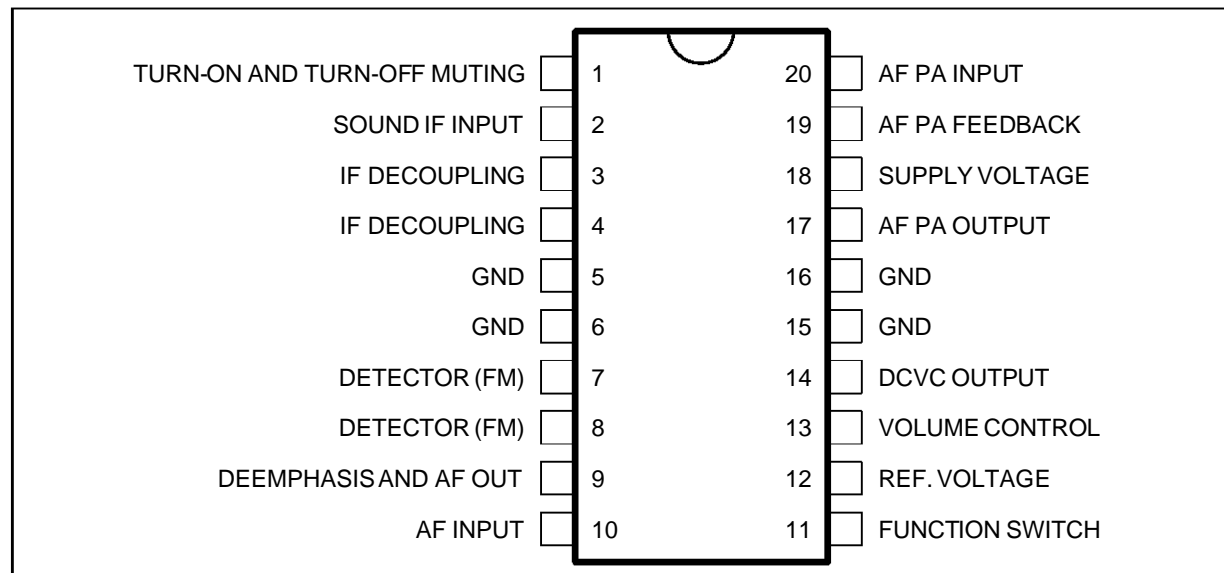

8191-01.EPS

TDA8191

BLOCK DIAGRAM

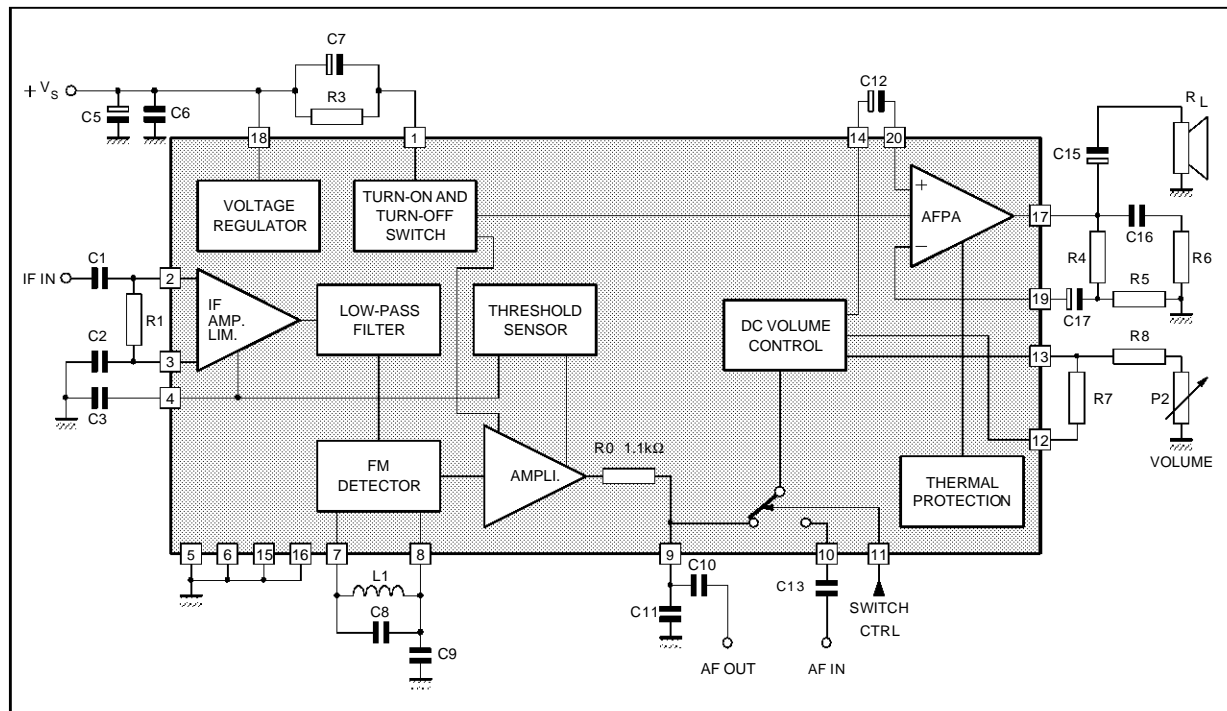

8191-02.EPS

ABSOLUTE MAXIMUM RATINGS

Symbol	Parameter	Value	Unit
V_S	Supply Voltage (pin 18)	28	V
V_I	Voltage at Pin 1	$\pm V_S$	
V_I	Input Voltage (pin 2)	1	V _{PP}
I_O	Output Peak Current (repetitive)	1.5	A
I_O	Output Peak Current (non repetitive)	2	A
P_{tot}	Total Power Dissipation : at $T_{pins} = 90^\circ\text{C}$ at $T_{amb} = 70^\circ\text{C}$	4.3 1	W W
T_{stg}, T_j	Storage and Junction Temperature	- 40 to 150	$^\circ\text{C}$

8191-01.TBL

THERMAL DATA

Symbol	Parameter	Value	Unit
$R_{th(j-pins)}$	Junction-pins Thermal Resistance	Max 14	$^\circ\text{C/W}$
$R_{th(j-a)}$	Junction-ambient Thermal Resistance	Max 80	$^\circ\text{C/W}$

8191-02.TBL

ELECTRICAL CHARACTERISTICS

(Refer to fig. 1 ; $V_S = 24\text{V}$, $R_L = 16\Omega$, Pin 11 floating, $\Delta f = \pm 50\text{kHz}$, $V_i = 1\text{mV}$, $f_o = 5.5\text{MHz}$, $f_m = 1\text{kHz}$, $T_{amb} = 25^\circ\text{C}$ unless otherwise specified)

Symbol	Parameter	Test Conditions	Min.	Typ.	Max.	Unit
V_S	Supply Voltage (Pin 18)	$V_C = 4.5\text{V}$	10.8	24	27	V
V_O	Quiescent Output Voltage (Pin 17)	$V_C = 4.5\text{V}$	11	12	13	V
V_I	Pin 1 DC Voltage	$V_C = 4.5\text{V}$		5.3		V
I_D	Quiescent Drain Current	$V_C = 4.5\text{V}$		35		mA
V_I	Input Limiting Voltage at Pin 2 (-3dB)	$V_O = 4V_{RMS}$		50	100	μV

8191-03.TBL

ELECTRICAL CHARACTERISTICS (continued)

(Refer to fig. 1 ; $V_S = 24V$, $R_L = 16\Omega$, Pin 11 floating, $\Delta f = \pm 50kHz$, $V_i = 1mV$, $f_o = 5.5MHz$, $f_m = 1kHz$, $T_{amb} = 25^\circ C$ unless otherwise specified)

Symbol	Parameter	Test Conditions	Min.	Typ.	Max.	Unit
V_9	Recovered Audio Voltage (pin 9)	$V_C = 4.5V$, $\Delta f = \pm 15kHz$	200		400	mV _{RMS}
R_9	Deemphasis Resistance	$f = 20Hz$ to $20kHz$	500	700	1000	Ω
AMR	Amplitude Modul. Rejection	$m = 0.3$, $V_O = 4V_{RMS}$	45	60		dB
R_I	Input Resistance (pin 2)	$\Delta f = 0$		30		k Ω
C_I	Input Capacitance (pin 2)	$\Delta f = 0$, $V_C = 4.5V$		6		pF
V_{12}	DCVC Reference Voltage		5.6		6.2	V
K_v	Volume Attenuation	$V_C = 0.5V$; Fig. 2 $V_C = 4.5V$; Fig. 2	80		1.0	dB dB
$\frac{\Delta K_v}{\Delta T_j}$	Volume Attenuation Thermal Drift	$T_j = 300$ to $380^\circ K$ Fig. 3		- 0.05	-0.1	dB/ $^\circ C$
P_O	Output Power (d = 10%)		3.5	4		W
SVR	Supply Voltage Rej. (Pin 17) (Pin 9)	$V_C = 4.5V$ $f_{ripple} = 100Hz$	20 50	26 60		dB dB
V_{11}	Function Switch. - Television Broadc. Reproduction - Peritelevision Reproduction		0 8		2 12	V V
R_{11}	Input Resistance		10			k Ω
V_{10}	Input Voltage (d \leq 2%)	$V_O = 4V_{RMS}$; $V_{11} = 12V$		0.5	2.0	V _{RMS}
R_{10}	Input Resistance	$f = 20Hz$ to $20kHz$	10			k Ω
CT	Crosstalk between Pins 9, 10		60			dB
$\frac{S+N}{N}$	Signal to Noise Ratio	$\Delta f = 0$; $V_O = 4V_{RMS}$	60	70		dB
d	Distortion ($P_O = 250mV$)				2	%
Δf	Deviation Sens.	$V_C = 0.5V$; $V_O = 4V_{RMS}$		± 4	± 10	kHz

8191-04.TBL

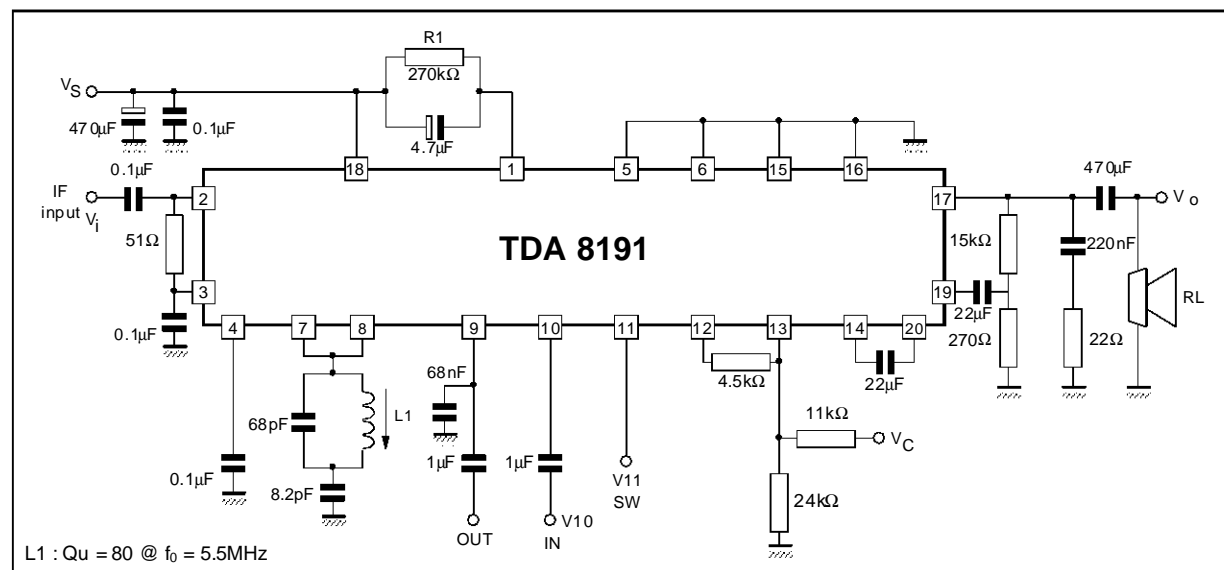
Figure 1 : Test Circuit

8191-03.EPS

TYPICAL APPLICATION

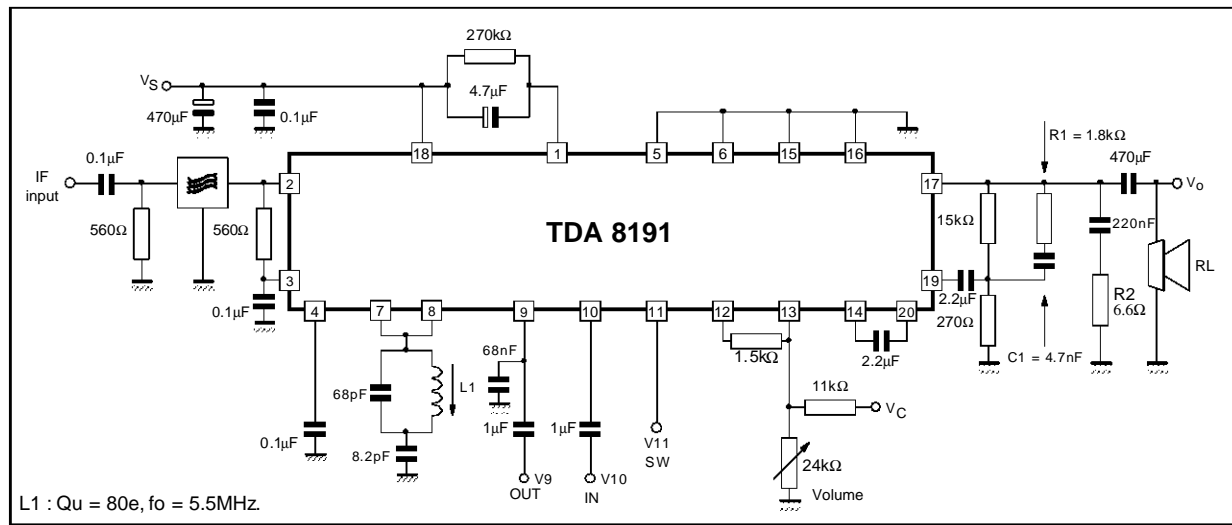

Figure 2 : Volume Attenuation versus DC Volume Control Voltage

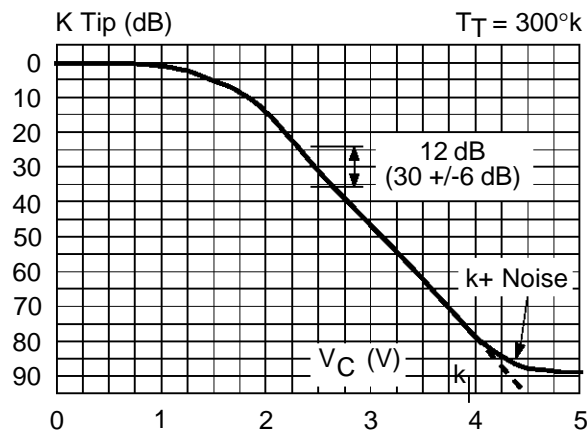

Figure 4 : Relative Audio Output Voltage and Output Noise versus Input Signal

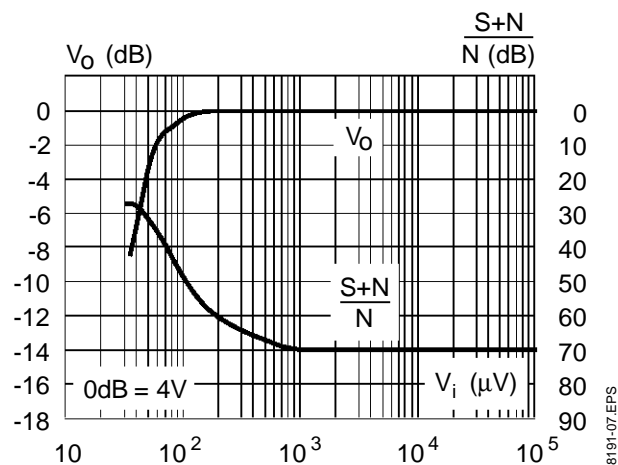

Figure 3 : Volume Attenuation Thermal Drift

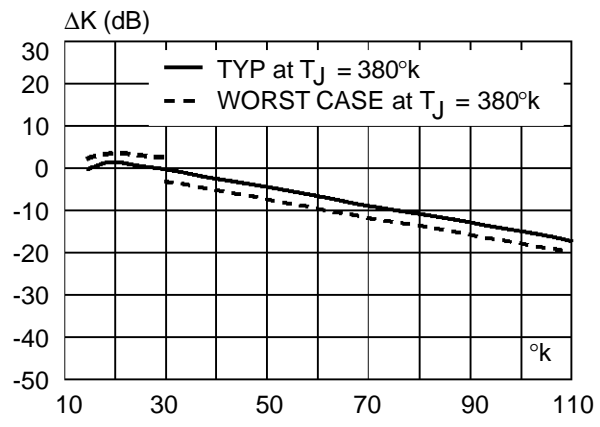

Figure 5 : Distortion versus Output Power

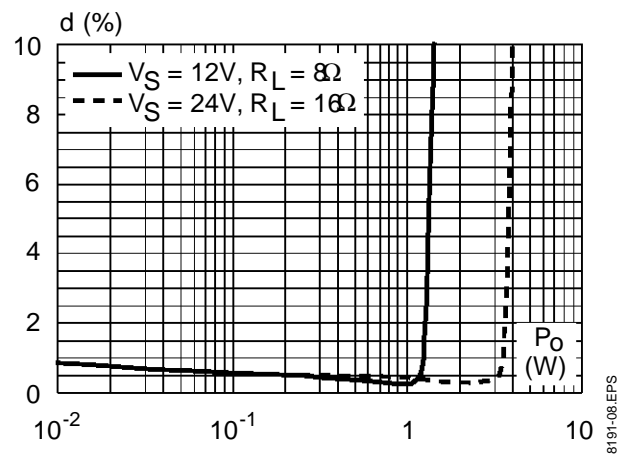

Figure 6 : Audio Amplifier Frequency Response

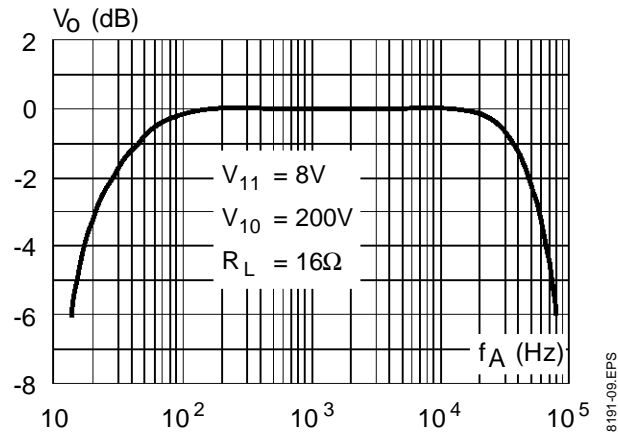

Figure 7 : Output Power versus Supply Voltage

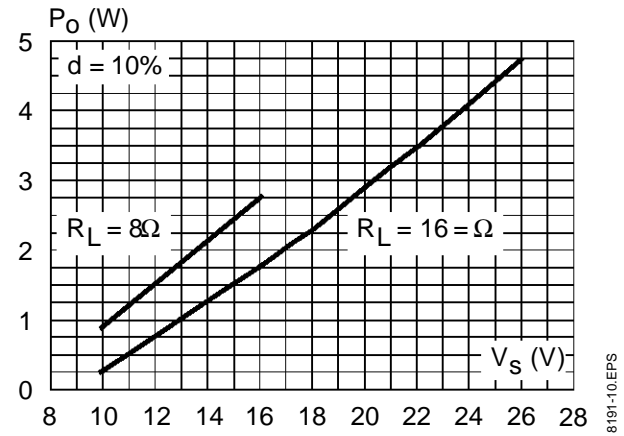

Figure 8 : Power Dissipation versus Supply Voltage (sine wave operation)

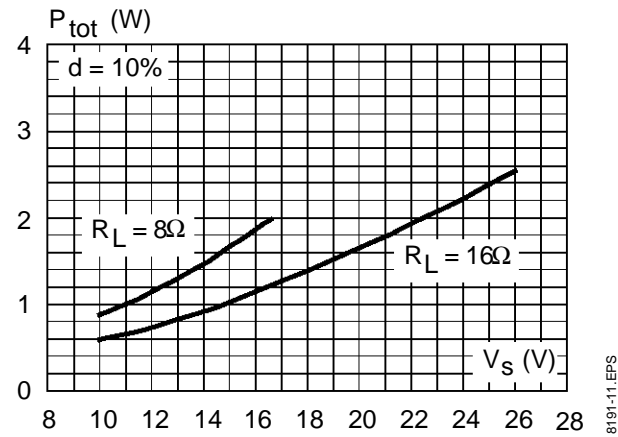

Figure 9 : Power Dissipation and Efficiency versus Output Power

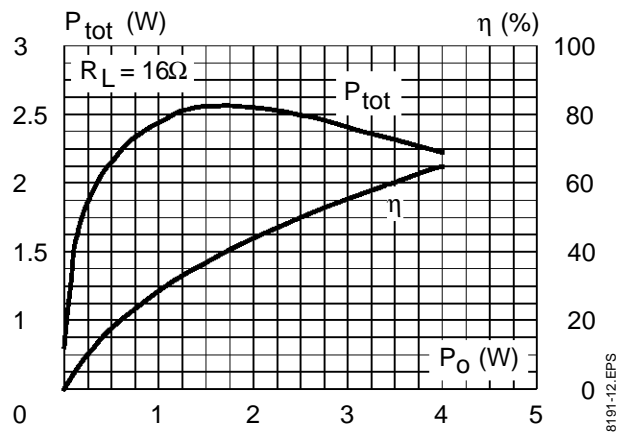
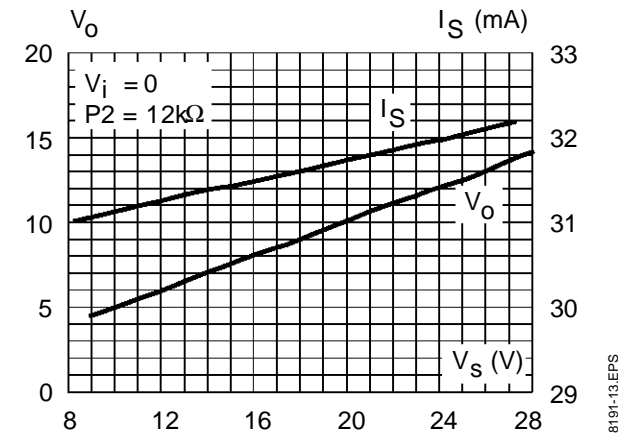
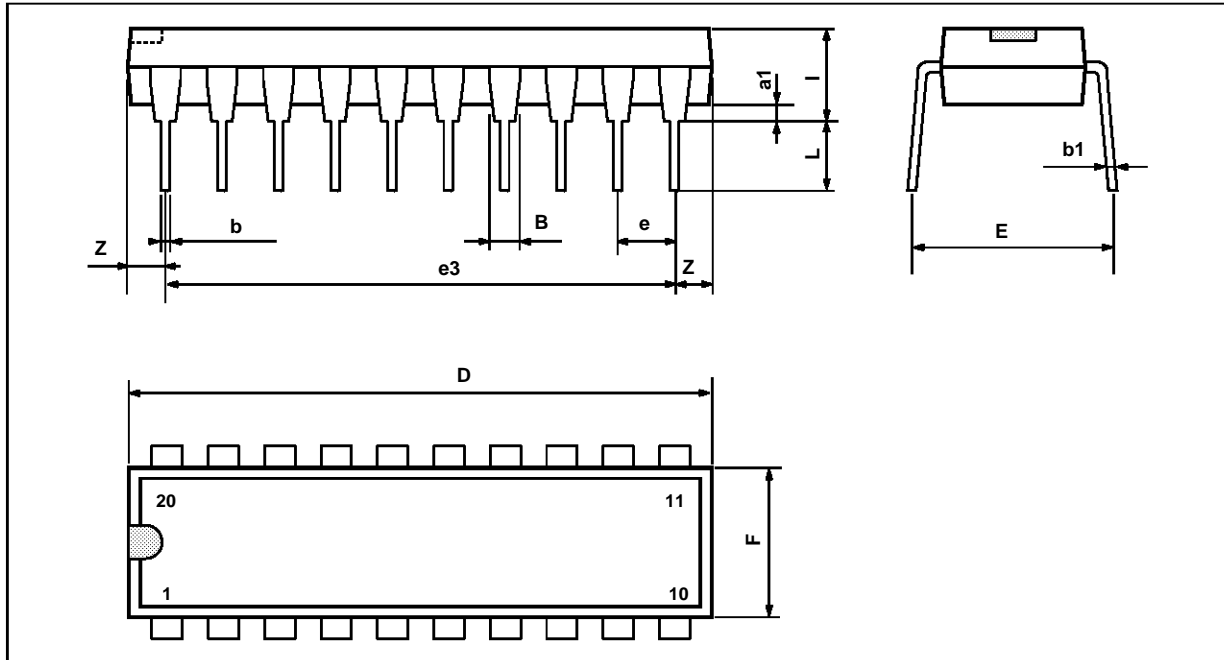

Figure 10 : Quiescent Drain and Quiescent Output Voltage versus Supply Voltage



PACKAGE MECHANICAL DATA
20 PINS - PLASTIC DIP



PM-DIP20.EPS

Dimensions	Millimeters			Inches		
	Min.	Typ.	Max.	Min.	Typ.	Max.
a1	0.254			0.010		
B	1.39		1.65	0.055		0.065
b		0.45			0.018	
b1		0.25			0.010	
D			25.4			1.000
E		8.5			0.335	
e		2.54			0.100	
e3		22.86			0.900	
F			7.1			0.280
i			3.93			0.155
L		3.3			0.130	
Z			1.34			0.053

DIP20.TBL

Information furnished is believed to be accurate and reliable. However, SGS-THOMSON Microelectronics assumes no responsibility for the consequences of use of such information nor for any infringement of patents or other rights of third parties which may result from its use. No licence is granted by implication or otherwise under any patent or patent rights of SGS-THOMSON Microelectronics. Specifications mentioned in this publication are subject to change without notice. This publication supersedes and replaces all information previously supplied. SGS-THOMSON Microelectronics products are not authorized for use as critical components in life support devices or systems without express written approval of SGS-THOMSON Microelectronics.

© 1994 SGS-THOMSON Microelectronics - All Rights Reserved

Purchase of I²C Components of SGS-THOMSON Microelectronics, conveys a license under the Philips I²C Patent. Rights to use these components in a I²C system, is granted provided that the system conforms to the I²C Standard Specifications as defined by Philips.

SGS-THOMSON Microelectronics GROUP OF COMPANIES

Australia - Brazil - China - France - Germany - Hong Kong - Italy - Japan - Korea - Malaysia - Malta - Morocco
The Netherlands - Singapore - Spain - Sweden - Switzerland - Taiwan - Thailand - United Kingdom - U.S.A.