

DATA SHEET

TDA8591J

**4 × 44 W into 4 Ω or 4 × 75 W
into 2 Ω quad BTL car radio power
amplifier**

Preliminary specification
File under Integrated Circuits, IC01

2002 Jan 14

4 × 44 W into 4 Ω or 4 × 75 W into 2 Ω quad BTL car radio power amplifier

TDA8591J

CONTENTS	15	PACKAGE OUTLINE
1 FEATURES	16	SOLDERING
2 GENERAL DESCRIPTION	16.1	Introduction to soldering through-hole mount packages
3 ORDERING INFORMATION	16.2	Soldering by dipping or by solder wave
4 QUICK REFERENCE DATA	16.3	Manual soldering
5 BLOCK DIAGRAM	16.4	Suitability of through-hole mount IC packages for dipping and wave soldering methods
6 PINNING	17	DATA SHEET STATUS
7 FUNCTIONAL DESCRIPTION	18	DEFINITIONS
7.1 Diagnostic facility	19	DISCLAIMERS
7.2 Diagnostic output (DIAG)		
7.3 Mute timer and single-pin mute control		
7.4 Output power		
8 LIMITING VALUES		
9 THERMAL CHARACTERISTICS		
10 QUALITY SPECIFICATION		
11 DC CHARACTERISTICS		
12 AC CHARACTERISTICS		
12.1 Performance curves		
13 TEST INFORMATION		
13.1 Protection circuit testing		
14 APPLICATION INFORMATION		
14.1 Special attention for SMD input capacitors		
14.2 Capacitors on outputs		
14.3 EMC precautions		
14.4 Offset detection		
14.5 Channel selection		
14.6 Detection of short-circuits		
14.7 PCB layout		
14.8 PCB design advice		

4 × 44 W into 4 Ω or 4 × 75 W into 2 Ω quad BTL car radio power amplifier

TDA8591J

1 FEATURES

- Low quiescent current
- Low distortion
- Low output offset voltage
- Soft thermal clipping to prevent audio holes
- External mute timer for low start-up plop (also allows a fast mute function)
- High output power
- Operating, mute and standby mode selection by two-pin or single-pin operation
- Diagnostic information available:
 - Dynamic Distortion Detection (DDD)
 - High temperature detection
 - Short-circuit detection
 - Detection of output offset due to leakage current at the input
- No switch-on/switch-off plops when switching between standby and mute modes or between mute and operating modes
- Fast mute with supply voltage drops
- Package with flexible leads

- All outputs can withstand short-circuits to ground, to the positive supply voltage and across the load
- Pin CP can withstand short-circuits to its adjacent pins, all other pins can withstand short-circuits to ground and to the positive supply voltage
- ESD protection on all pins
- Thermal protection against junction temperatures exceeding 150 °C
- Load dump protection
- Protected against open ground pins (loss of ground) and outputs short-circuited to supply ground
- All negative outputs are protected against open supply voltage and output short-circuited to supply voltage
- Reverse-polarity safe.

2 GENERAL DESCRIPTION

The TDA8591J is a quad BTL audio power amplifier comprising four independent amplifiers in Bridge Tied Load (BTL) configuration. Each amplifier has a gain of 26 dB and supplies an output power of 75 W (EIAJ) into a 2 Ω load. The TDA8591J has low quiescent current and is primarily developed for car audio applications.

3 ORDERING INFORMATION

TYPE NUMBER	PACKAGE		
	NAME	DESCRIPTION	VERSION
TDA8591J	DBS27P	plastic DIL-bent-SIL power package; 27 leads (lead length 7.7 mm)	SOT521-1

**4 × 44 W into 4 Ω or 4 × 75 W into 2 Ω
quad BTL car radio power amplifier**

TDA8591J

4 QUICK REFERENCE DATA

SYMBOL	PARAMETER	CONDITIONS	MIN.	TYP.	MAX.	UNIT
V_P	supply voltage		8.0	14.4	18.0	V
$I_{q(\text{tot})}$	total quiescent current		120	200	290	mA
I_{stb}	standby supply current		–	2	50	μA
$ Z_i $	input impedance		–	70	–	kΩ
P_o	output power	THD + N = 0.5%				
		$R_L = 4 \Omega$	19	22	–	W
		$R_L = 2 \Omega$	–	34	–	W
		THD + N = 10%				
$R_L = 4 \Omega$	27	28	–	W		
$R_L = 2 \Omega$	–	47	–	W		
EAIJ values	$R_L = 4 \Omega$	41.5	44	–	W	
	$R_L = 2 \Omega$	–	75	–	W	
$ V_{OO} $	output offset voltage	mute mode	–	–	30	mV
		DC operating mode	–	–	60	mV
G_v	voltage gain	$V_i = 40 \text{ mV (RMS)}$	25	26	27	dB
THD + N	total harmonic distortion plus noise	$P_o = 1 \text{ W}; f = 1 \text{ kHz}; R_L = 4 \Omega$	–	0.03	0.1	%
α_{cs}	channel separation	$V_i = 40 \text{ mV (RMS)}; R_s = 0 \Omega$	56	68	–	dB
$V_{n(o)}$	noise output voltage	$R_s = 0 \Omega$; see Fig.29	–	70	–	μV
SVRR	supply voltage ripple rejection	$V_{\text{ripple}} = 2 \text{ V (p-p)}$; mute or operating mode; $R_s = 0 \Omega$; see Fig.29	54	68	–	dB

4 × 44 W into 4 Ω or 4 × 75 W into 2 Ω
quad BTL car radio power amplifier

TDA8591J

5 BLOCK DIAGRAM

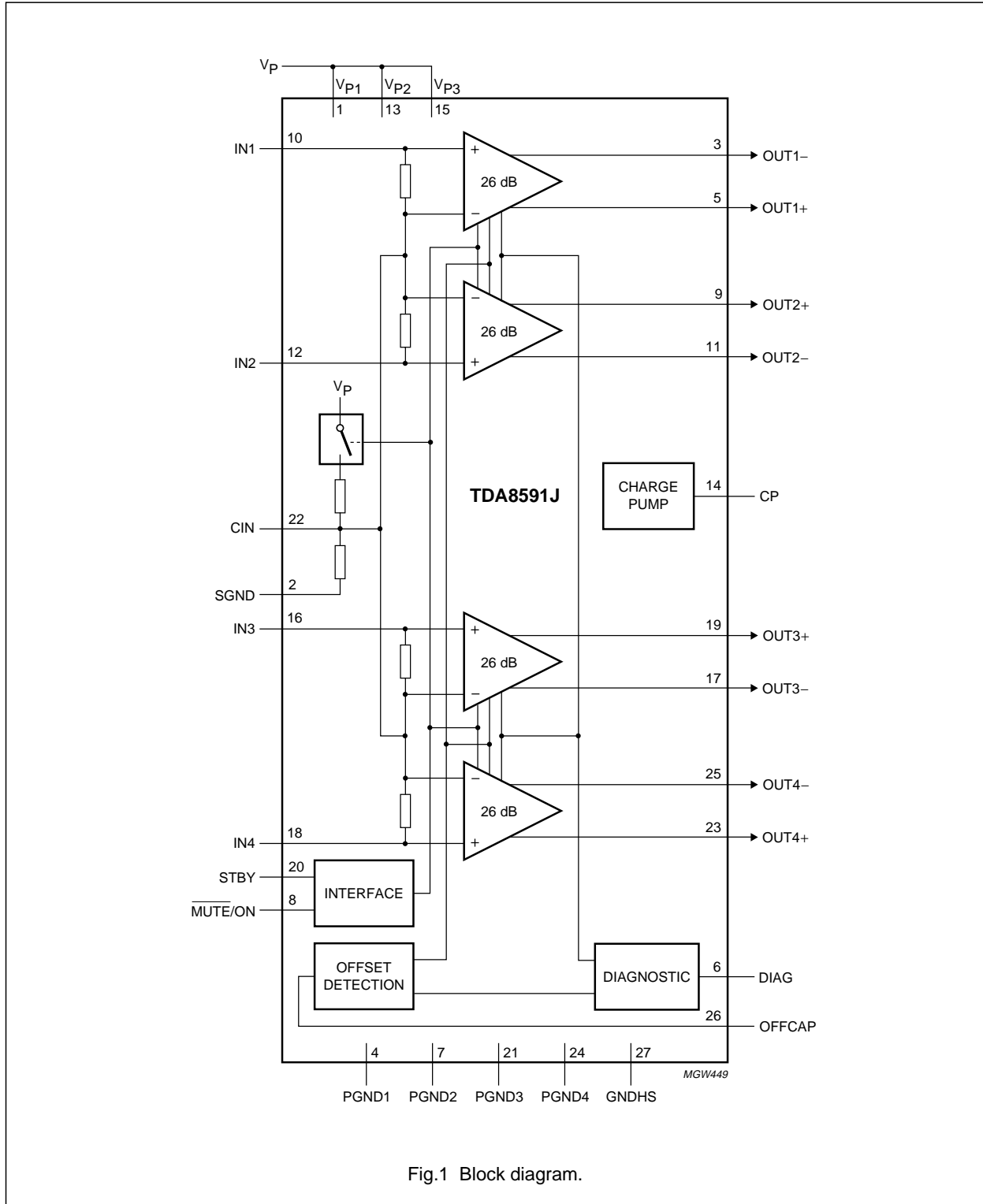

4 × 44 W into 4 Ω or 4 × 75 W into 2 Ω quad BTL car radio power amplifier

TDA8591J

6 PINNING

SYMBOL	PIN	DESCRIPTION
V _{P1}	1	power supply to channels 1 and 4
SGND	2	signal ground
OUT1-	3	channel 1 negative output
PGND1	4	channel 1 power ground
OUT1+	5	channel 1 positive output
DIAG	6	diagnostic output
PGND2	7	channel 2 power ground
MUTE/ON	8	mode select input: mute/amplifier operating (via mute timer)
OUT2+	9	channel 2 positive output
IN1	10	channel 1 input
OUT2-	11	channel 2 negative output
IN2	12	channel 2 input
V _{P2}	13	channel 2 power supply
CP	14	charge pump capacitor
V _{P3}	15	channel 3 power supply
IN3	16	channel 3 input
OUT3-	17	channel 3 negative output
IN4	18	channel 4 input
OUT3+	19	channel 3 positive output
STBY	20	standby select input
PGND3	21	channel 3 power ground
CIN	22	common input voltage
OUT4+	23	channel 4 positive output
PGND4	24	channel 4 power ground
OUT4-	25	channel 4 negative output
OFFCAP	26	offset detection capacitor
GNDHS	27	ground (heatsink of encapsulation)

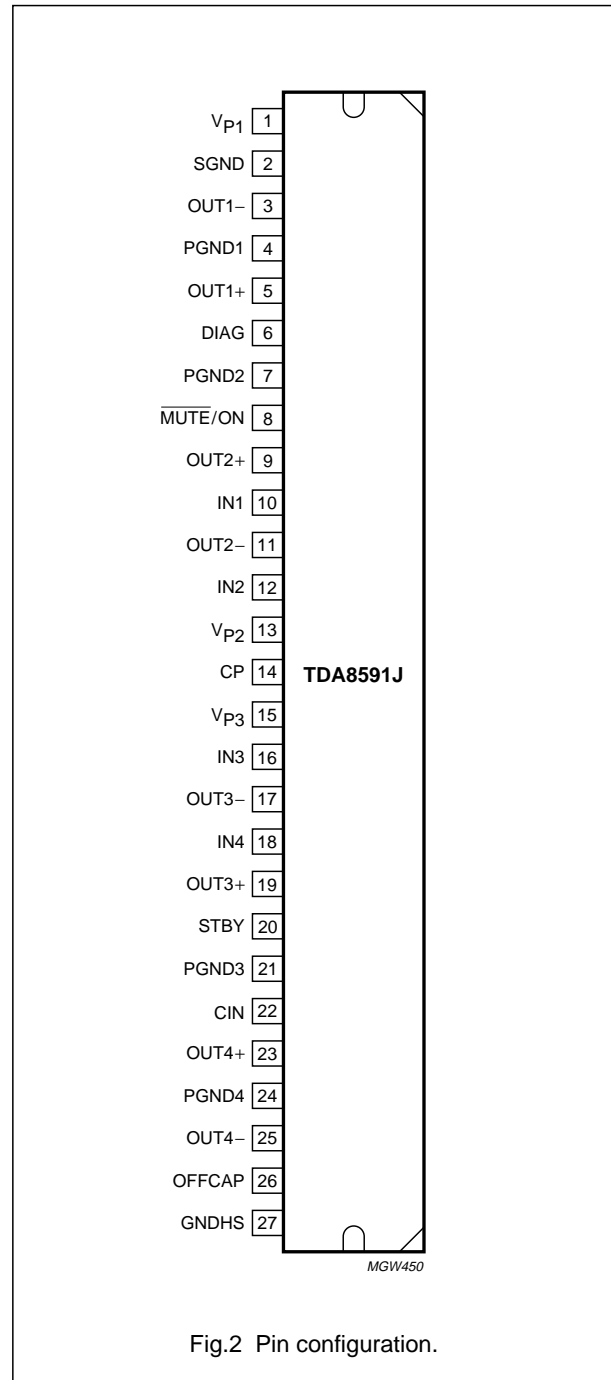

4 × 44 W into 4 Ω or 4 × 75 W into 2 Ω quad BTL car radio power amplifier

TDA8591J

7 FUNCTIONAL DESCRIPTION

The TDA8591J is an audio power amplifier with four independent Bridge Tied Load (BTL) amplifiers with high output power and low distortion. The gain of each amplifier is fixed at 26 dB. The TDA8591J has two-pin mode control which allows the amplifiers to be switched to standby (off) with the STBY pin, and the MUTE/ON pin to be used to switch between mute mode (input signal suppressed) and amplifier operating mode.

Special attention is paid to dynamic behaviour:

- A fast mute that switches all amplifiers to mute mode at low supply voltage and suppresses noise during engine start
- No pops when switching between standby and mute modes
- Slow offset change when switching from mute mode to operating mode (can be adjusted by an external capacitor)
- A fast mute function by discharging the external mute capacitor quickly

The following protection circuits are included to prevent the IC from being damaged:

- Thermal shutdown:
At junction temperature $T_{vj} > 170\text{ °C}$, all power stages are switched off to prevent a further increase in temperature
- Soft thermal clipping:
At junction temperature $T_{vj} > 155\text{ °C}$, the gain reduces as temperature increases, resulting in less output power and decreasing temperature and therefore no thermal shutdown (no break in the audio)
- Short-circuit protection:
If a short-circuit to ground or supply voltage occurs at one or more of the output pins, or across the load of one or more of the channels, the following action occurs to reduce power dissipation and case temperature (see Figs 5 and 6):
 - All amplifiers switch off for approximately 20 ms
 - After 20 ms the amplifiers switch on again
 - If the short-circuit persists, the amplifiers switch off for another 20 ms period and the action repeats
- ESD protection:
 - Human body model 2000 V
 - Machine model 200 V
- Protection against open ground pins and outputs short-circuited to supply ground (see Fig.30)

- All outputs protected are against open power supply pins and outputs short-circuited to power supply voltage (see Fig.31)
- With a reversed polarity power supply an external diode conducts and a fuse blows and therefore the reversed polarity voltage will not damage the device (see Fig.32).

7.1 Diagnostic facility

A diagnostic facility is available from the status of pin DIAG for the following conditions:

- In normal operation, the level on the DIAG pin is continuously HIGH (see Fig.3)
- When a temperature pre-warning occurs due to the junction temperature T_{vj} reaching 145 °C, the DIAG pin goes continuously LOW
- When there is distortion over 2.5% because of clipping, the DIAG pin has a pulsed output as shown in Fig.4
- When a short-circuit is detected, the short-circuit protection becomes active and DIAG goes continuously LOW for the period of the short-circuit (see Figs 5 and 6)
- With an extreme output offset, input leakage current causes a DC output offset voltage and results in power dissipation in the loudspeakers. Therefore, if the DC output offset voltage of a bridge is larger than 2 V, DIAG is pulled LOW to indicate an error condition.

The DIAG pin has an open-drain output to allow several devices to be tied together. An external pull-up resistor is needed.

**4 × 44 W into 4 Ω or 4 × 75 W into 2 Ω
quad BTL car radio power amplifier**

TDA8591J

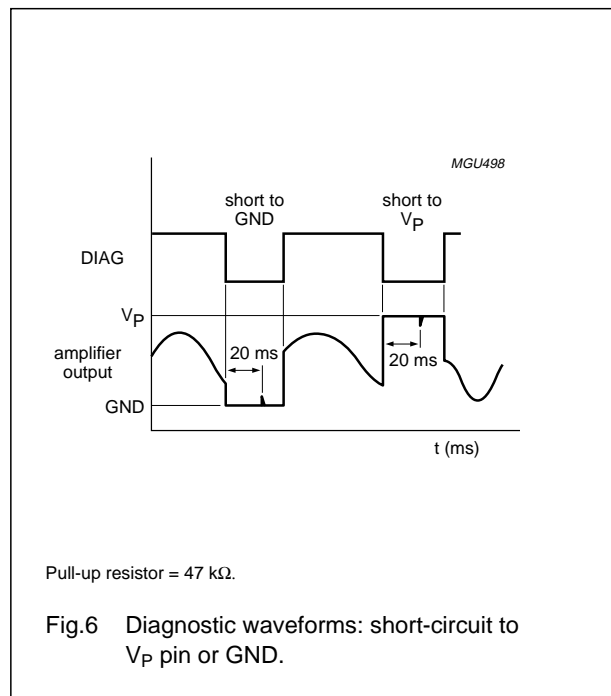
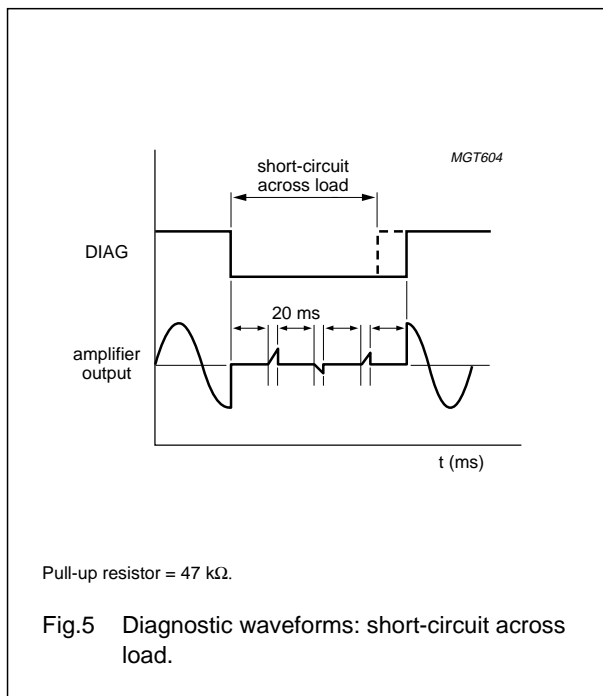
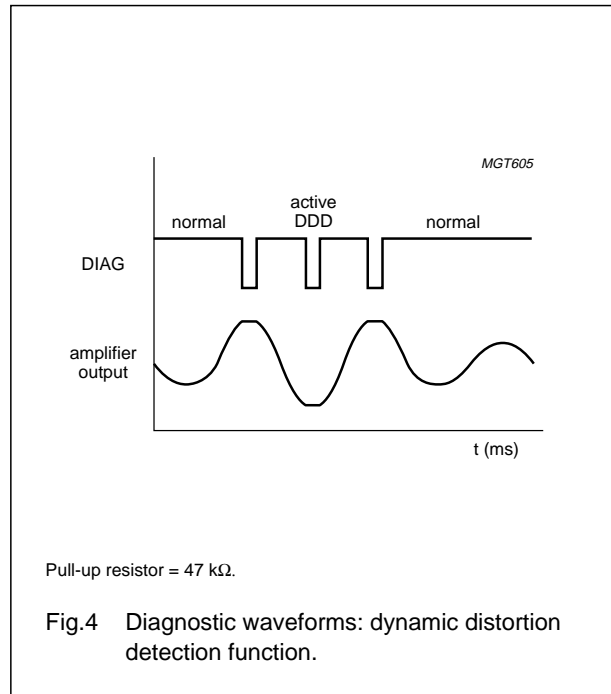
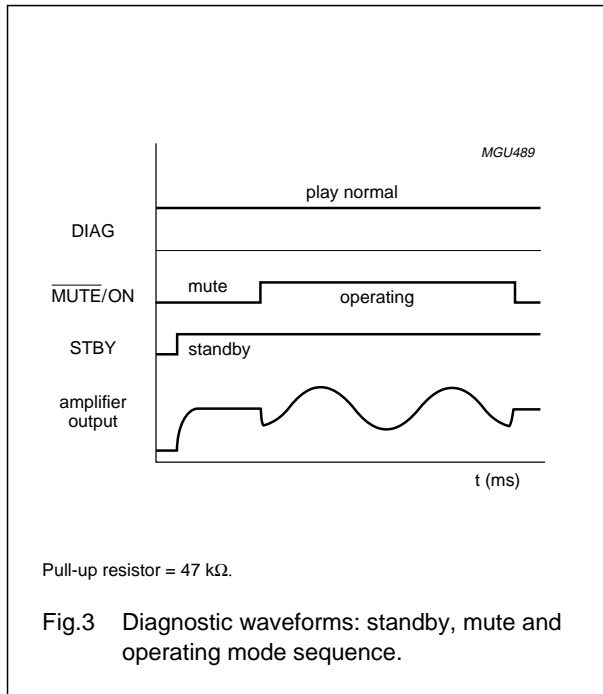

4 × 44 W into 4 Ω or 4 × 75 W into 2 Ω quad BTL car radio power amplifier

TDA8591J

7.2 Diagnostic output (DIAG)

The internal circuit of the diagnostic open-drain output is shown in Fig.7.

A pull-up resistor is required if the diagnostic output is connected to a microcontroller. Figure 8 shows four possible solutions for fault diagnosis.

Figures 8a and 8b show simple configurations. The output offset diagnostic cannot trigger the microcontroller because of the 4-diode stack, only the temperature, short-circuit and dynamic distortion diagnostic will give an input LOW level for the microcontroller.

In Fig.8c, the diagnostic output is connected to an external level shifter. Now DIAG pin output can also generate an input LOW level for the microcontroller.

Assuming that a microcontroller HIGH input level must be equal to, or greater than 2 V, the following equations are used to calculate values for resistors R1 and R2:

$$V_{IN1} > 2 \text{ V and } V_{IN1} = 5 \text{ V} - 4 \times V_d - R2 \times \left(\frac{5 \text{ V} - 4 \times V_d}{R1 + R2} \right)$$

where:

5 V is the pull-up supply voltage

V_d is the forward voltage of a diode (0.6 V)

R1 and R2 are the resistors in the level shifter.

$$\text{Using both equations: } R1 > \frac{2 \times R2}{5 \text{ V} - 4 \times V_d - 2}$$

thus $R1 > 3.3 R2$

Therefore, R1 can be 47 kΩ and R2 can be 10 kΩ.

The level shifter shown in Fig.8d is used as a 2-bit analog-to-digital converter.

With reference to Figs 7 and 8c, the truth table in Table 1 can be made:

Table 1 Truth table.

HIGH TEMPERATURE OR SHORT-CIRCUIT OR DDD	OFFSET	IN1	IN2
no	no	1	1
no	yes	0	1
yes	don't care	0	0

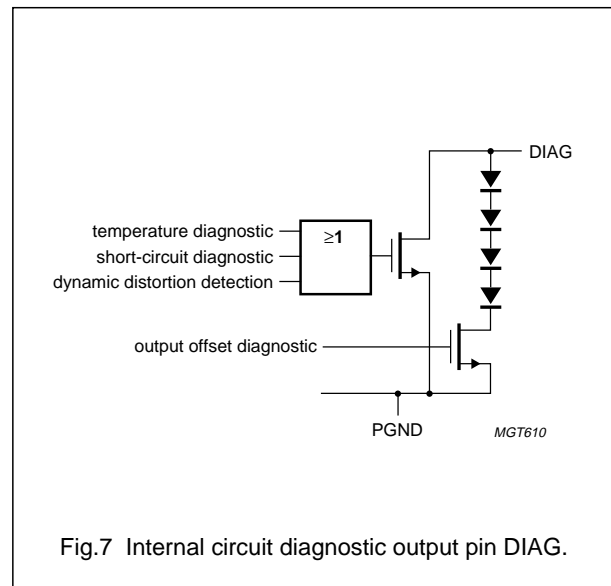
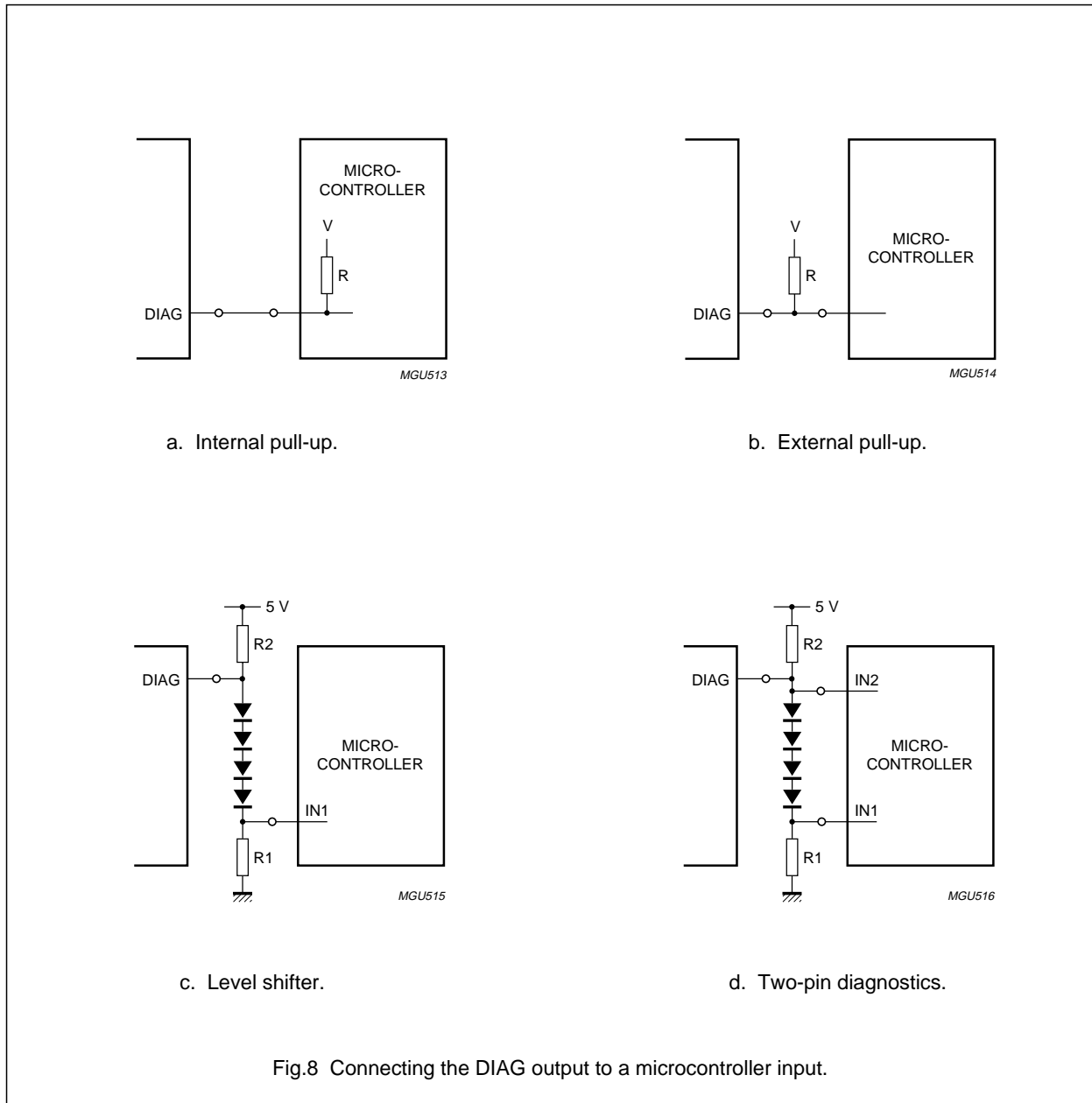

Fig.7 Internal circuit diagnostic output pin DIAG.

$4 \times 44 \text{ W}$ into 4Ω or $4 \times 75 \text{ W}$ into 2Ω
quad BTL car radio power amplifier

TDA8591J



4 × 44 W into 4 Ω or 4 × 75 W into 2 Ω quad BTL car radio power amplifier

TDA8591J

7.3 Mute timer and single-pin mute control

The transition time from mute mode to operating mode can be used to hide pops that occur during switching. This transition time is determined by the value of the external capacitor at the $\overline{\text{MUTE}}/\text{ON}$ input (see Fig.33). To guarantee the mute suppression, the resistor value may not be more than 15 kΩ. The switching can be controlled by a transistor switch with an open-drain output or a voltage output with a minimum high level of 5.5 V.

When controlling with an open-drain output, the high voltage level also must be at least 5.5 V and should not be clamped on a lower value by the ESD diode of the microcontroller. If the minimum high voltage cannot be guaranteed, an external open-drain transistor or switch to ground can be used. Charging of the external capacitor at the $\overline{\text{MUTE}}/\text{ON}$ input is done by an internal current source.

If muting is performed by the microcontroller, the mute connection to the microcontroller can be omitted. The mute on and off transitions during start-up and switch-off are controlled by an internal push-pull current source and the external capacitor at pin 8 ($\overline{\text{MUTE}}/\text{ON}$).

Fast mute can be achieved by quickly discharging the mute capacitor by means of an open-drain transistor without a series resistor.

7.4 Output power

EIAJ power is a power rating which indicates the maximum possible output power of a specific application at a nominal supply voltage. The power losses caused by PCB layout, copper area, connector block, coil, loudspeaker wires, etc. depend on the applications.

Therefore, the EIAJ power is defined and measured at the pins of the IC using the following test conditions:

- The supply voltage is 14.4 V measured on the pins of the TDA8591J
- All channels are loaded with 4 Ω and are driven simultaneously
- The input signal is a continuous (no burst) square wave: $V = 1 \text{ V (RMS)}$; $f = 1 \text{ kHz}$
- RMS output power is measured immediately at the start (cold heatsink) and after 1 minute of operation. The mean value is the rated EIAJ power.

To have optimum output power performance, the external heatsink should be chosen carefully. A small heatsink causes a high junction temperature, resulting in an increase of the drain-source on-state resistance ($R_{\text{DS(on)}}$) of the power amplifiers and a decrease of the maximum output power.

The reason for using a square wave input signal for EIAJ power measurement is illustrated in Fig.9.

Figure 9a shows a square wave signal with

$$\text{slew rate} = \frac{V_{\text{top}}}{t_r}$$

Assuming this square wave is the output signal of an amplifier, the EIAJ output power is given by

$$P_{\text{EIAJ}} = \frac{V_{\text{top}}^2}{R_L} \times \frac{1 - \left(\frac{8}{3}\right) \times V_{\text{top}} \times f}{\text{slew rate}}$$

where:

R_L = load resistor in Ω

V_{top} = maximum voltage across the load in V

f = frequency of the square wave in Hz

t_r = rise time of the slope in s.

A sine wave has a lower slew rate than a square wave as shown in Fig.9b, therefore EIAJ power measurement with a sine wave will give a lower power value. The maximum slew rate of a sine wave output signal is given by

$$\frac{\delta U_{\text{out}}}{\delta t \text{ max}} = \frac{\delta(A \times \sin(2\pi f \times t))}{\delta t \text{ max}} = 2\pi f \times A$$

where:

A = amplitude of the output sinewave in V

f = frequency of the output sinewave in Hz.

For a non-clipping sinewave output with amplitude $A = 13 \text{ V}$ and frequency $f = 1 \text{ kHz}$, the slew rate is

$$\frac{\delta U_{\text{out}}}{\delta t \text{ max}} = 82^3 \text{ V/s}$$

A faster slew rate can be obtained by increasing the amplitude: for an amplitude of 28 V, the slew rate will increase to 1.8⁵ V/s. A supply voltage of $V_P = 14.4 \text{ V}$ will result in a clipped output with a shape similar to a square wave but with a slower slew rate.

Figure 9c shows the dependency of P_{EIAJ} on slew rate. Using a square wave input signal, the EIAJ output power is determined by the drop voltage and bandwidth of the output stage.

**4 × 44 W into 4 Ω or 4 × 75 W into 2 Ω
quad BTL car radio power amplifier**

TDA8591J

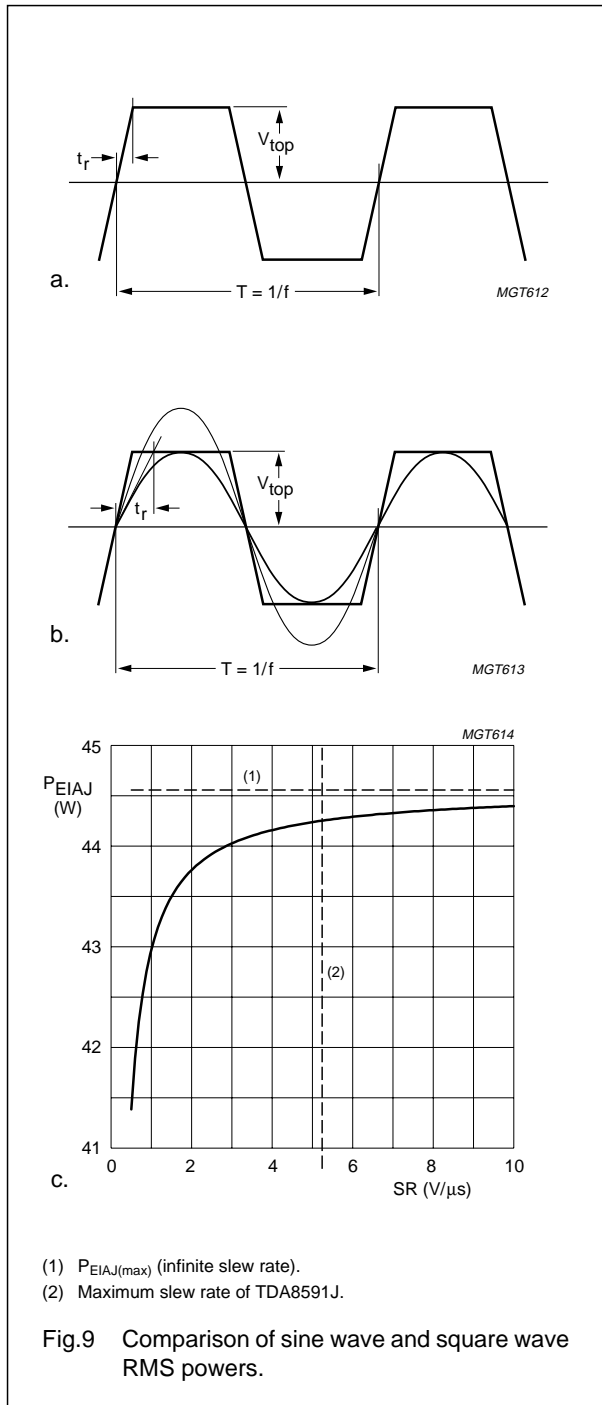

4 × 44 W into 4 Ω or 4 × 75 W into 2 Ω quad BTL car radio power amplifier

TDA8591J

8 LIMITING VALUES

In accordance with the Absolute Maximum Rating System (IEC 60134).

SYMBOL	PARAMETER	CONDITIONS	MIN.	MAX.	UNIT
V _P	supply voltage	operating	–	18	V
		not operating	–1	+45	V
		with load dump protection (see Fig.10)	–	45	V
V _{DIAG}	voltage on pin DIAG		–	45	V
I _{OSM}	non-repetitive peak output current		–	10	A
I _{ORM}	repetitive peak output current		–	6	A
V _{sc}	AC and DC short-circuit voltage	short-circuit of output pins across loads and to ground or supply	–	18	V
V _{rp}	reverse polarity voltage	t ≤ 1 ms	–	6	V
P _{tot}	total power dissipation	T _{case} = 70 °C	–	80	W
T _{vj}	virtual junction temperature		–	150	°C
T _{stg}	storage temperature		–55	+150	°C
T _{amb}	ambient temperature		–40	+85	°C
V _{esd}	electrostatic handling voltage	note 1	2000	–	V
		note 2	200	–	V

Notes

- Human body model: C = 100 pF; R_s = 1500 Ω; all pins have passed all tests to 2500 V to guarantee 2000 V, according to "General Quality Specification SNW-FQ-611D", class II, except pin GND, which passed 2200 V, class Ia.
- Machine model: C = 200 pF; R_s = 10 Ω; L = 0.75 mH.

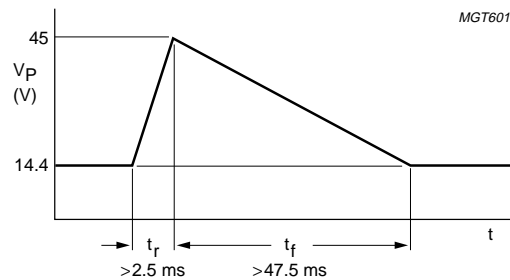

Fig.10 Load dump pulse definition.

4 × 44 W into 4 Ω or 4 × 75 W into 2 Ω quad BTL car radio power amplifier

TDA8591J

9 THERMAL CHARACTERISTICS

SYMBOL	PARAMETER	CONDITIONS	VALUE	UNIT
$R_{th(j-a)}$	thermal resistance from junction to ambient	in free air	40	K/W
$R_{th(j-c)}$	thermal resistance from junction to case	see Fig.11	1	K/W

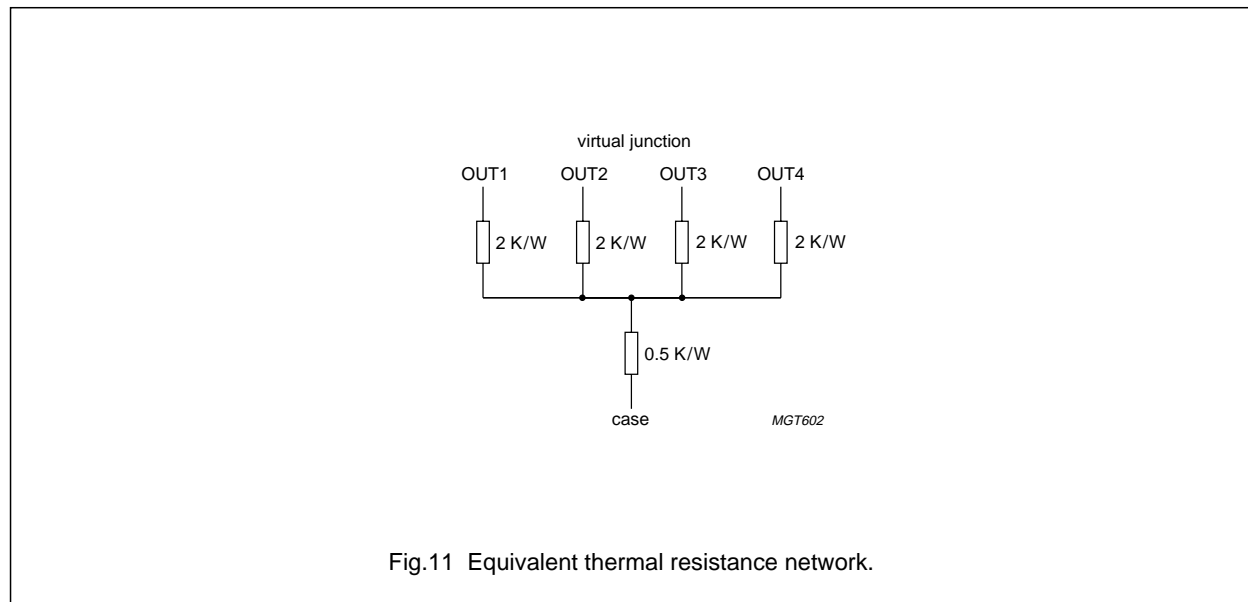

10 QUALITY SPECIFICATION

Quality according to "SNW-FQ-611E".

11 DC CHARACTERISTICS

$T_{amb} = 25\text{ °C}$; $R_L = \infty$; $V_P = V_{P1} = V_{P2} = V_{P3} = 14.4\text{ V}$; measured in the circuit of Fig.29; unless otherwise specified.

SYMBOL	PARAMETER	CONDITIONS	MIN.	TYP.	MAX.	UNIT
Supplies						
V_P	supply voltage		8.0	14.4	18.0	V
$I_{q(tot)}$	total quiescent current		120	200	290	mA
I_{stb}	standby current		–	2	50	μA
V_O	DC output voltage		–	7.2	–	V
$V_{P(mute)}$	low supply voltage mute	operating to mute mode	6.0	7.0	8.0	V
		mute to operating mode	6.3	7.0	8.5	V
$V_{P(mute)(hys)}$	low supply voltage mute hysteresis		–	0.4	–	V
$ V_{OO} $	output offset voltage	mute mode; $V_{MUTE/ON} = 0\text{ V}$	–	0	30	mV
		operating mode; $V_{MUTE/ON} = 5\text{ V}$	–	0	60	mV

4 × 44 W into 4 Ω or 4 × 75 W into 2 Ω
quad BTL car radio power amplifier

TDA8591J

SYMBOL	PARAMETER	CONDITIONS	MIN.	TYP.	MAX.	UNIT
STBY and MUTE/ON inputs (see Table 2)						
V _{STBY}	control voltage on pin STBY	standby mode	0	–	0.8	V
V _{STBY(hys)}	voltage hysteresis on pin STBY		–	0.2	–	V
V _{MUTE/ON}	voltage on pin MUTE/ON	mute mode; V _{STBY} > 2.5 V	–	–	0.8	V
		operating mode; V _{STBY} > 2.5 V; note 1	5.5	–	V _P	V
I _{STBY}	STBY pin current	V _{STBY} = 5 V	–	–	80	μA
I _{MUTE/ON}	MUTE/ON pin current	V _{MUTE/ON} = 5.5 V	–	25	–	μA
DIAG output (see Figs 3 to 6)						
V _{DIAG}	diagnostic output voltage	I _{DIAG(sink)} = 250 μA DDD, protection circuits and temperature pre-warning active	–	0.3	0.8	V
		offset diagnostic active	2.0	2.8	3.2	V
I _L	leakage current	V _{DIAG} = 14.4 V	–	–	1	μA
THD	total harmonic distortion at clip detection	V _{DIAG} < 0.8 V	–	1.5	–	%
V _{OO(det)}	output offset voltage detection; note 2	2.0 < V _{DIAG} < 3.2 V	2.5	4.5	6.5	V
T _{vj}	virtual junction temperature	temperature pre-warning; V _{DIAG} < 0.8 V	135	145	–	°C
		soft thermal clipping; G _v = –3 to –23 dB	–	155	–	°C
		temperature shut-down	–	170	–	°C

Notes

1. With open MUTE/ON pin, the TDA8591J will switch to operating mode (see Section 7.3)
2. V_{OO(det)} is the offset voltage across the load. Pin OFFCAP should never be left open-circuit. If pin OFFCAP is connected to one of the PGND pins, the offset detection is switched off (see Section 14.4).

Table 2 Mode selection

STBY	MUTE/ON	AMPLIFIER MODE
0	don't care	standby (off)
1	0	mute (DC settled)
1	1	operating

4 × 44 W into 4 Ω or 4 × 75 W into 2 Ω quad BTL car radio power amplifier

TDA8591J

12 AC CHARACTERISTICS

$V_P = V_{P1} = V_{P2} = V_{P3} = 14.4 \text{ V}$; $R_L = 4 \Omega$; $f = 1 \text{ kHz}$; $T_{\text{amb}} = 25 \text{ °C}$; measured in the circuit of Fig.29; unless otherwise specified.

SYMBOL	PARAMETER	CONDITIONS	MIN.	TYP.	MAX.	UNIT
P_o	output power	THD + N = 0.5 % $R_L = 4 \Omega$	20	22	–	W
		$R_L = 2 \Omega$	–	34	–	W
		THD + N = 1 %; $R_L = 2 \Omega$	–	35	–	W
		THD + N = 10 % $R_L = 4 \Omega$	27	28	–	W
		$R_L = 2 \Omega$	–	47	–	W
	EIAJ values $R_L = 4 \Omega$		41.5	44	–	W
		$R_L = 2 \Omega$	–	75	–	W
G_v	voltage gain	$V_i = 40 \text{ mV (RMS)}$	25	26	27	dB
THD + N	total harmonic distortion plus noise	$P_o = 1 \text{ W}$; $f = 1 \text{ kHz}$	–	0.03	0.1	%
		$P_o = 10 \text{ W}$; $f = 10 \text{ kHz}$	–	0.2	–	%
α_{cs}	channel separation	$V_i = 40 \text{ mV (RMS)}$; $R_s = 0 \Omega$	56	68	–	dB
$ \Delta G_v $	channel unbalance		–	–	1	dB
$V_{n(o)}$	noise output voltage	$R_s = 0 \Omega$; note 1 operating mode	–	70	110	μV
		mute mode	–	16	–	μV
$V_{o(\text{mute})}$	output voltage in mute mode	mute mode; $V_i = 1 \text{ V (RMS)}$	–	16	30	μV
SVRR	supply voltage ripple rejection	$V_{\text{ripple}} = 2 \text{ V (p-p)}$; mute or operating mode; $R_s = 0 \Omega$	54	68	–	dB
Z_i	input impedance	$V_i \leq 3 \text{ V (RMS)}$	60	70	–	$k\Omega$
CMRR	common mode rejection ratio	$R_s = 0 \Omega$; $V_{cm} = 0.35 \text{ V (RMS)}$	–	70	–	dB
B_P	power bandwidth	THD + N = 0.5%; $P_o = -1 \text{ dB}$ with respect to 17 W	–	20 to 20000	–	Hz
$f_{ro(l)}$	low frequency roll-off	at -1 dB ; note 2	–	25	–	Hz
$f_{ro(h)}$	high frequency roll-off	at -1 dB	150	300	–	kHz

Notes

1. The noise output voltage is measured in a bandwidth of 20 Hz to 20 kHz.
2. The frequency response is fixed with external components.

**4 × 44 W into 4 Ω or 4 × 75 W into 2 Ω
quad BTL car radio power amplifier**

TDA8591J

12.1 Performance curves

Conditions for Figs 12 to 28 unless otherwise specified are: $V_P = 14.4\text{ V}$; $R_L = 4\ \Omega$; $f = 1\text{ kHz}$; 80 kHz filter.

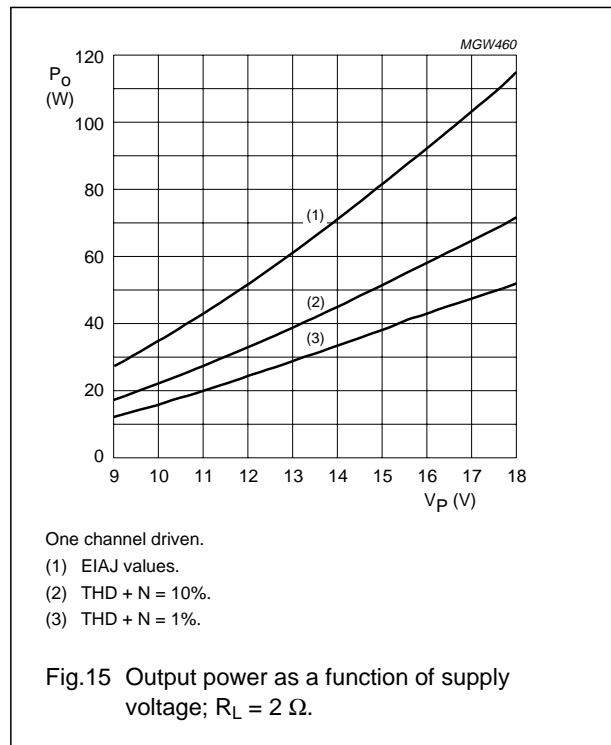
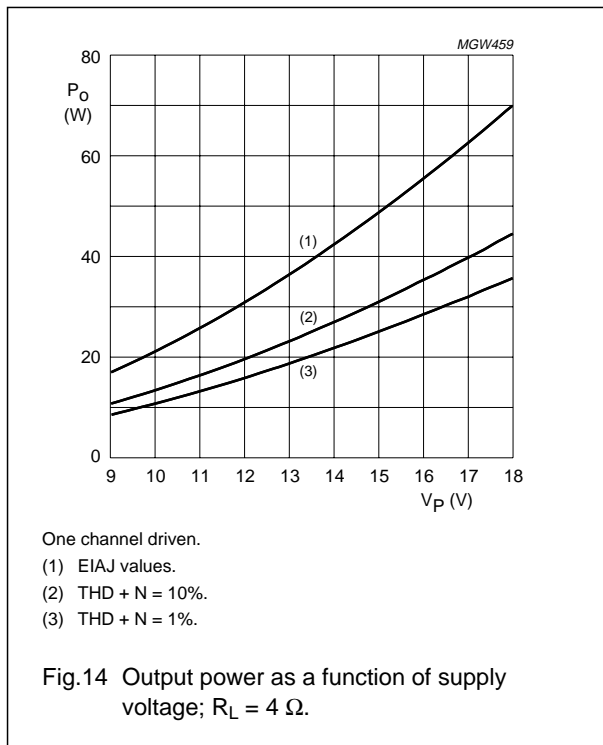
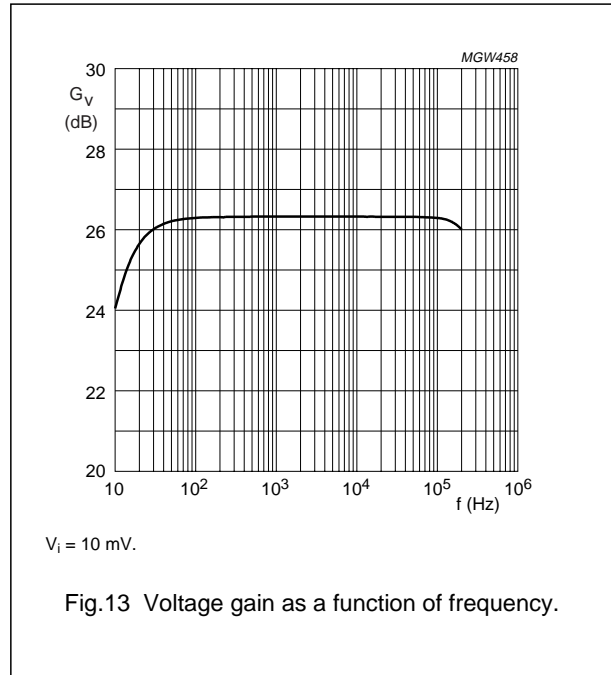
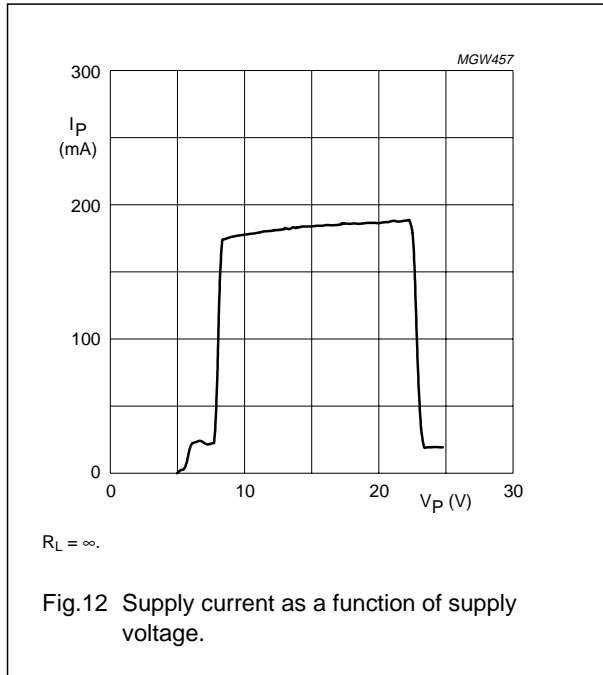

**4 × 44 W into 4 Ω or 4 × 75 W into 2 Ω
quad BTL car radio power amplifier**

TDA8591J

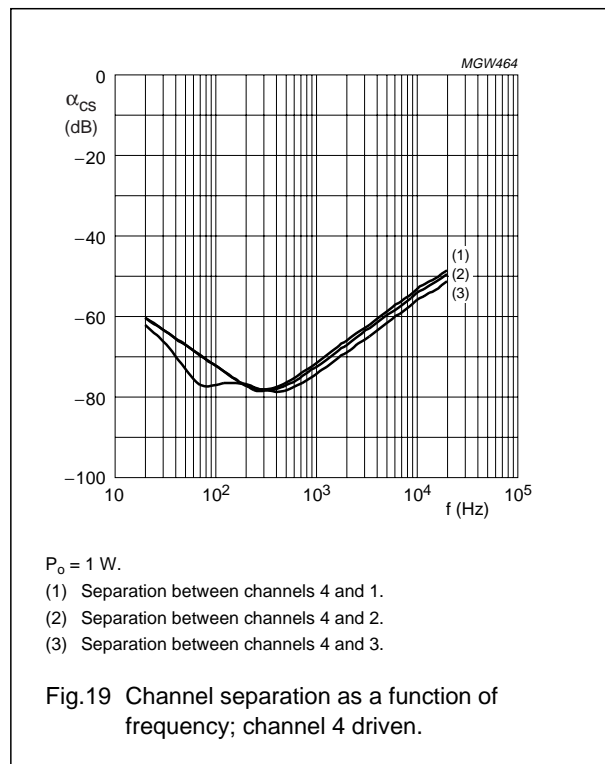
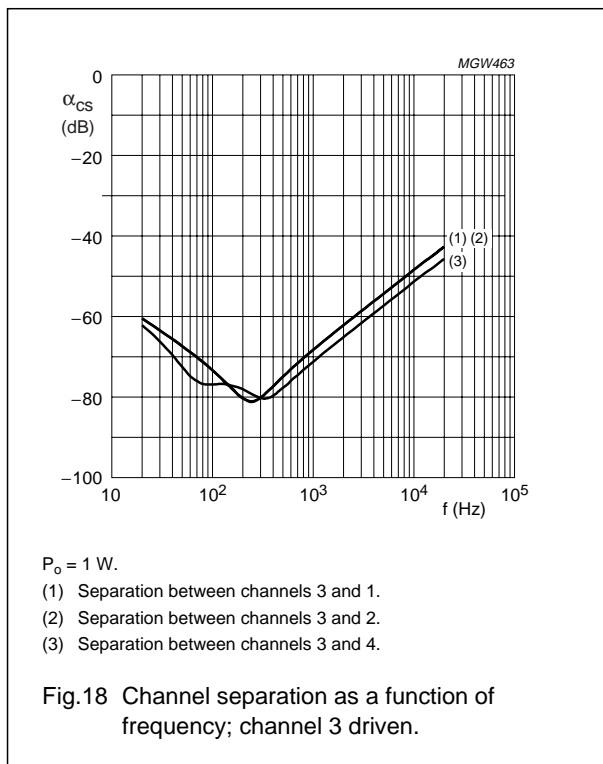
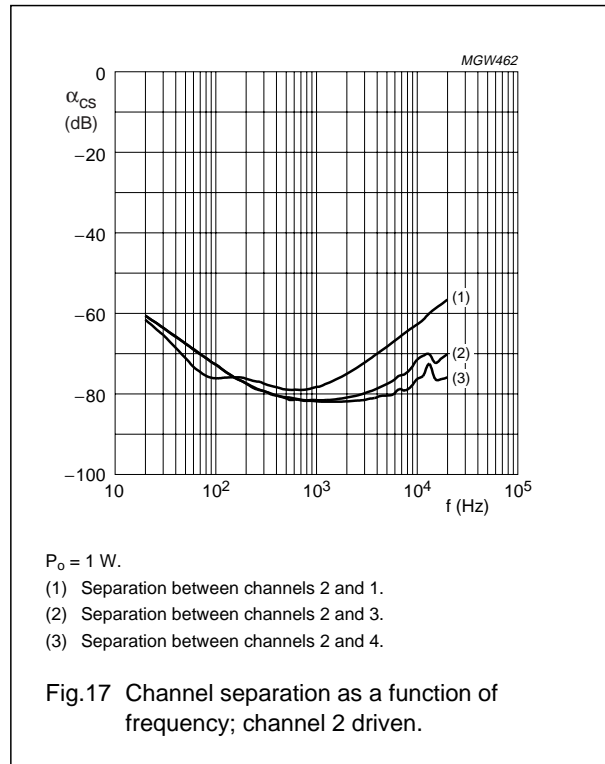
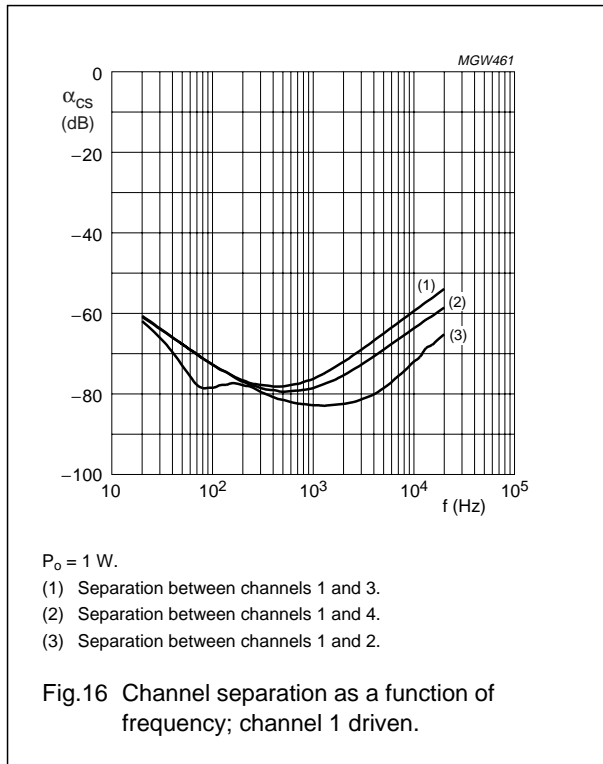

4 × 44 W into 4 Ω or 4 × 75 W into 2 Ω
quad BTL car radio power amplifier

TDA8591J

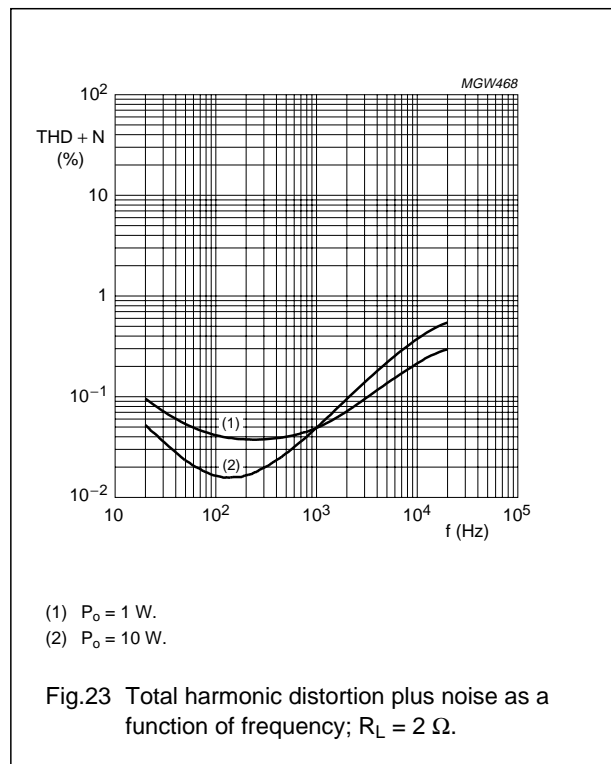
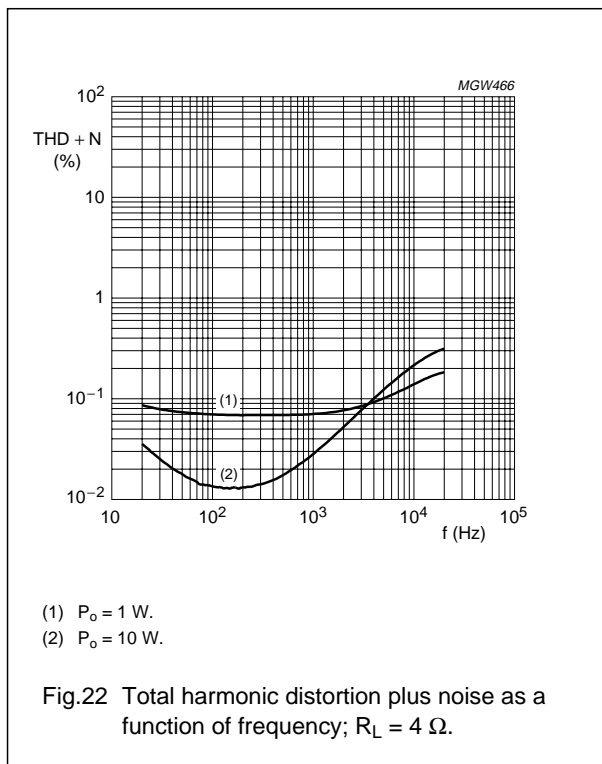
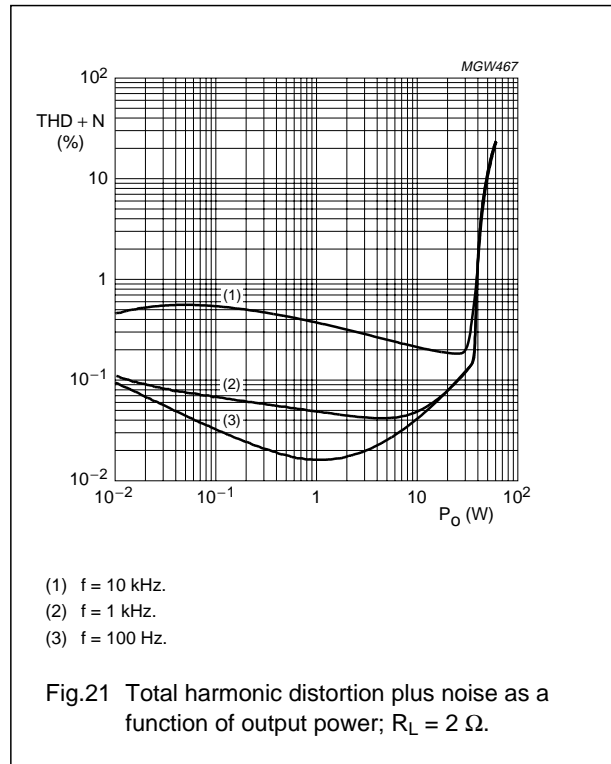
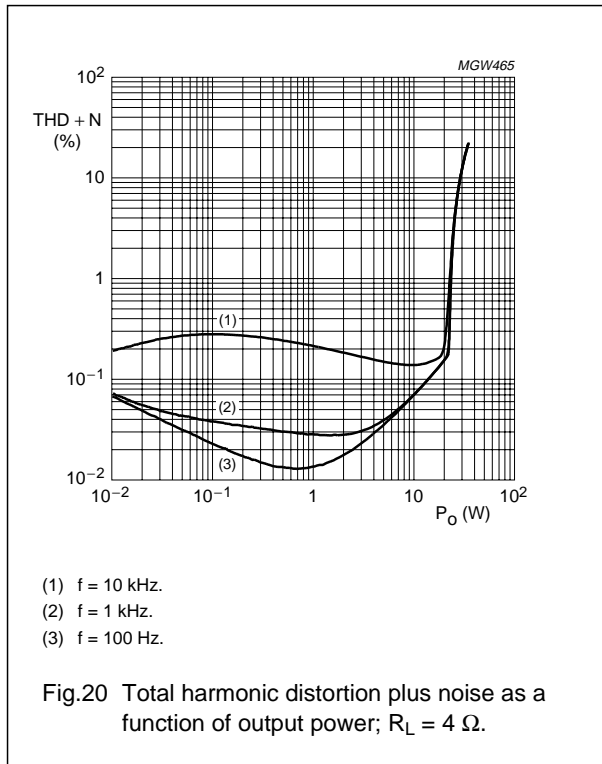

**4 × 44 W into 4 Ω or 4 × 75 W into 2 Ω
quad BTL car radio power amplifier**

TDA8591J

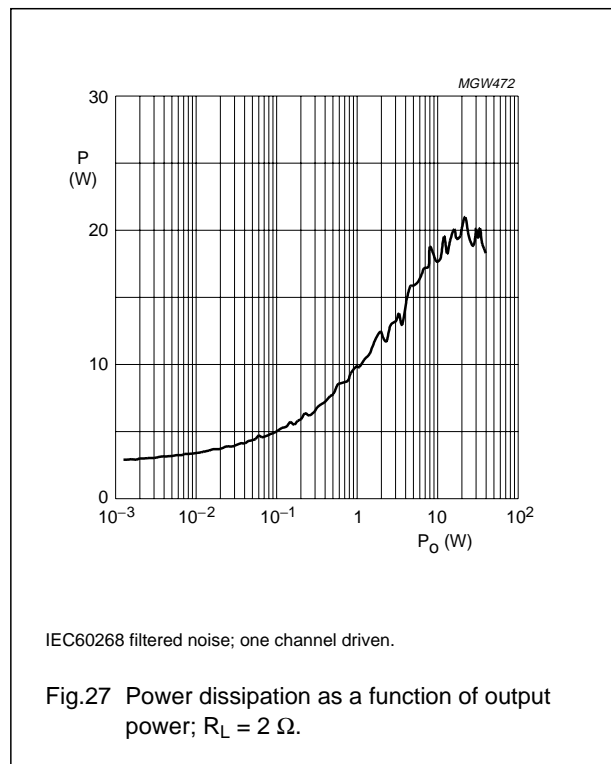
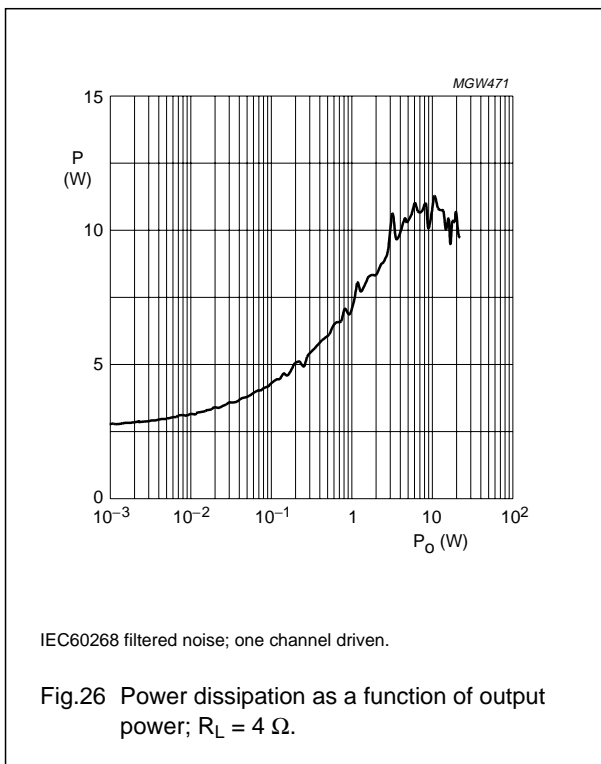
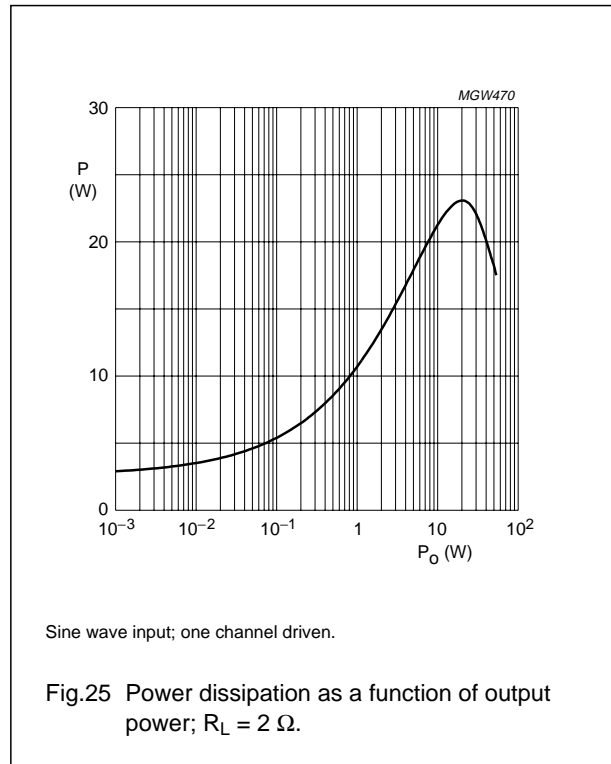
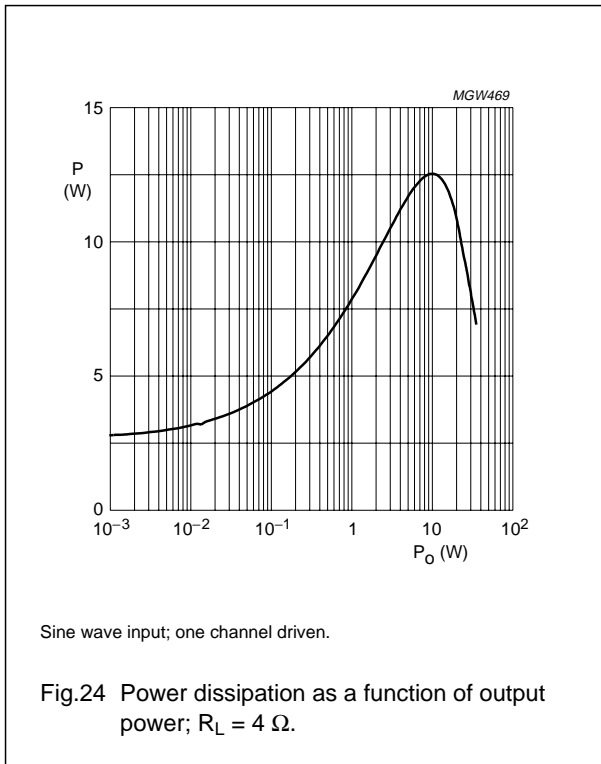

4 × 44 W into 4 Ω or 4 × 75 W into 2 Ω
quad BTL car radio power amplifier

TDA8591J

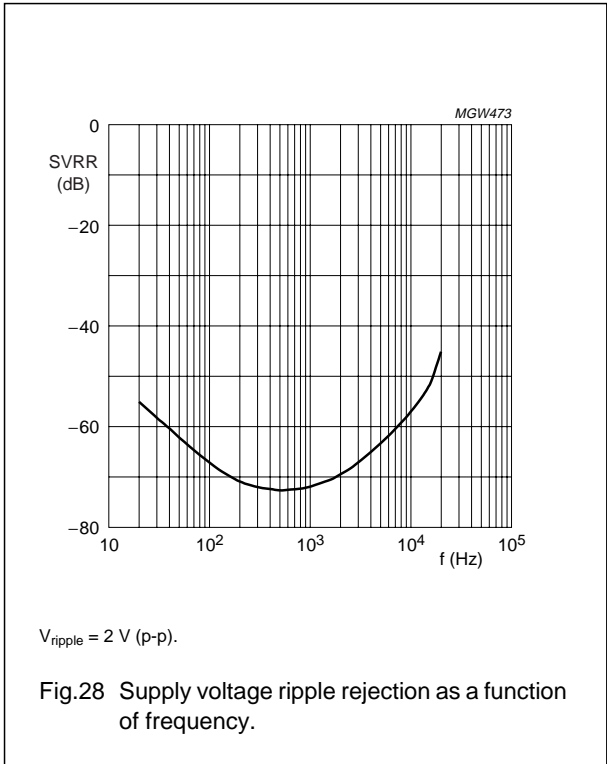

4 × 44 W into 4 Ω or 4 × 75 W into 2 Ω
quad BTL car radio power amplifier

TDA8591J

13 TEST INFORMATION

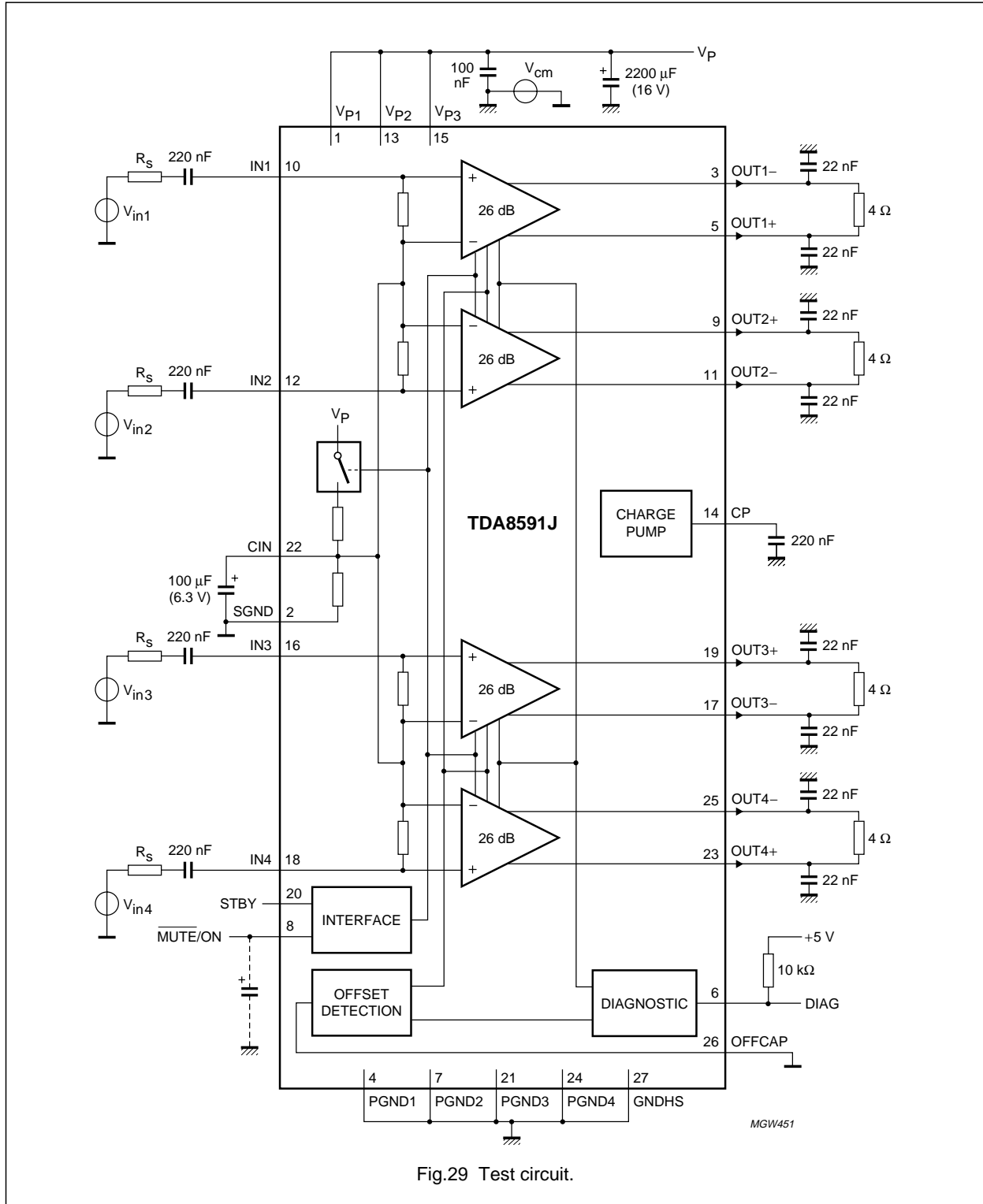
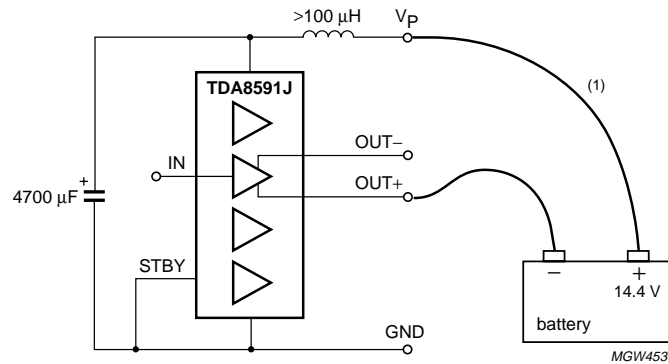

Fig.29 Test circuit.

4 × 44 W into 4 Ω or 4 × 75 W into 2 Ω quad BTL car radio power amplifier

TDA8591J

13.1 Protection circuit testing



One channel output shown.

At the start of the test, the 4700 µF capacitor should be discharged.

The amplifier is in standby during test.

(1) Cable length is 1 metre, cable diameter is 1.5 mm.

Fig.30 Open ground pin test set-up.

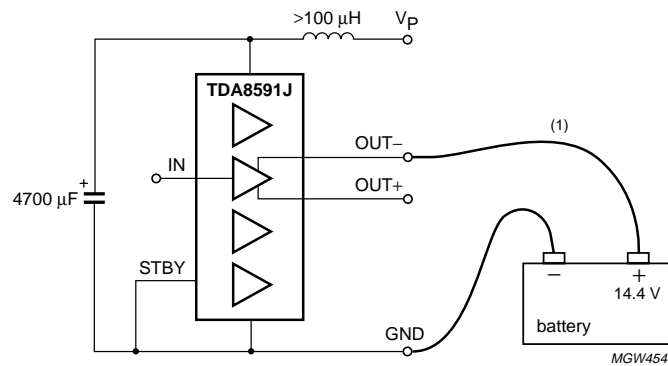

One channel output shown.

At the start of the test, the 4700 µF capacitor should be discharged.

The amplifier is in standby during test.

(1) Cable length is 1 metre, cable diameter is 1.5 mm.

Fig.31 Open power supply (pin V_P) test set-up.

$4 \times 44 \text{ W}$ into 4Ω or $4 \times 75 \text{ W}$ into 2Ω
quad BTL car radio power amplifier

TDA8591J

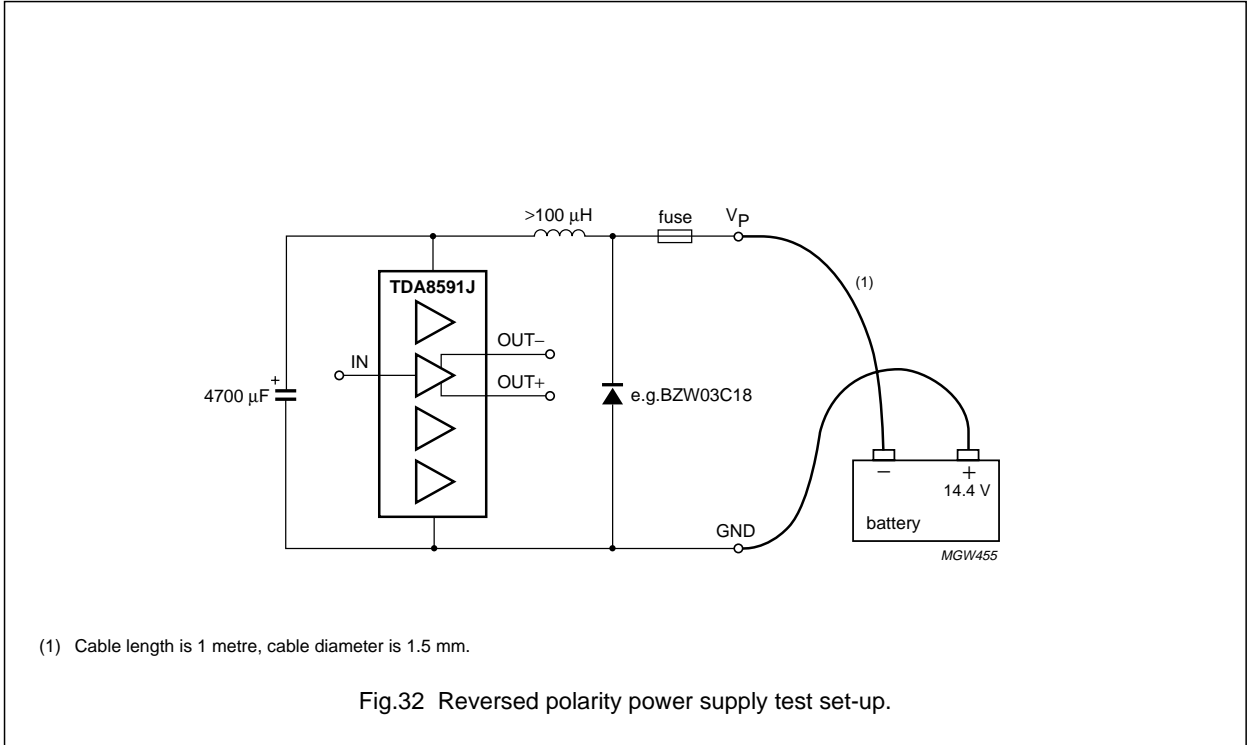

4 × 44 W into 4 Ω or 4 × 75 W into 2 Ω
quad BTL car radio power amplifier

TDA8591J

14 APPLICATION INFORMATION

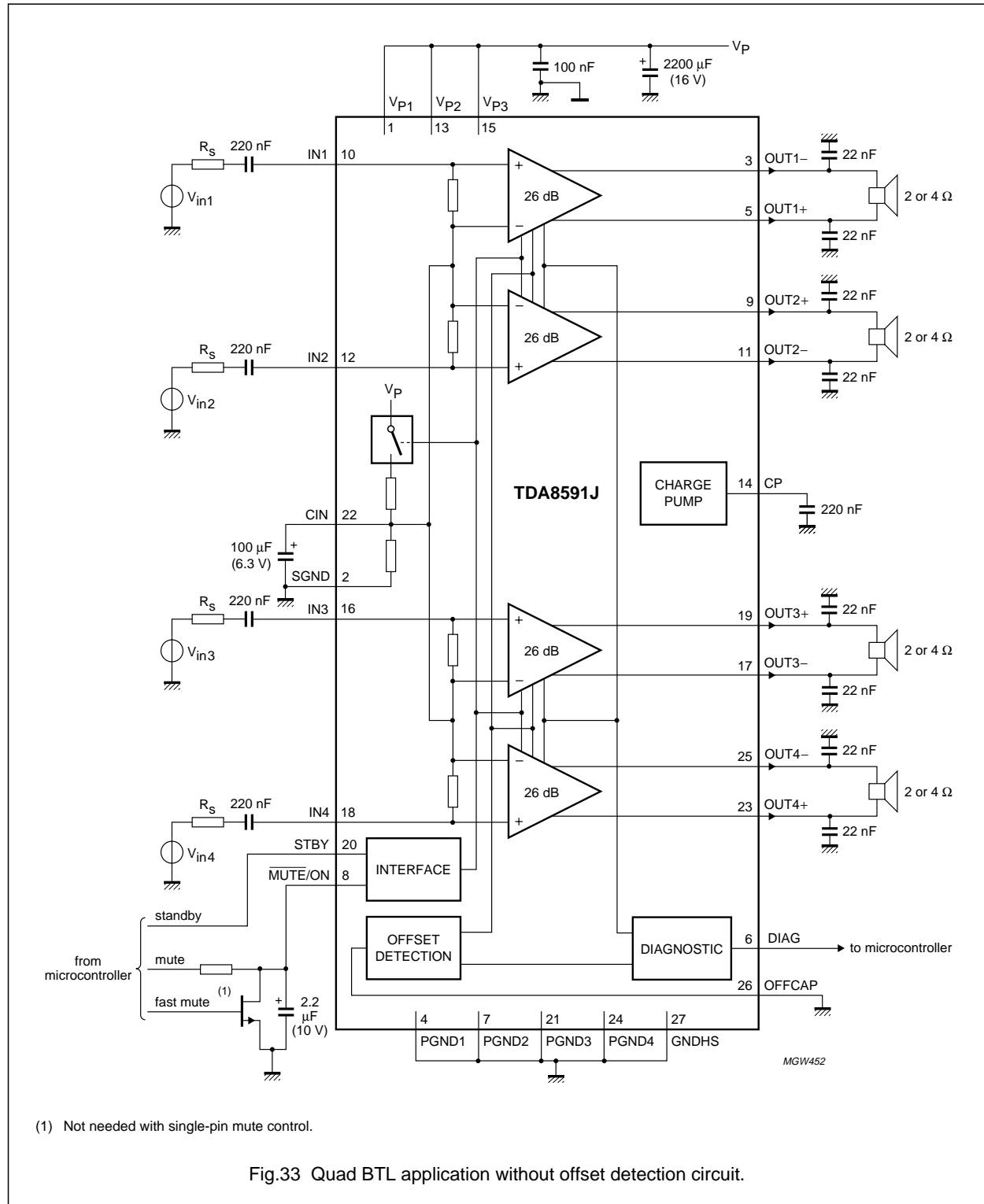

4 × 44 W into 4 Ω or 4 × 75 W into 2 Ω
quad BTL car radio power amplifier

TDA8591J

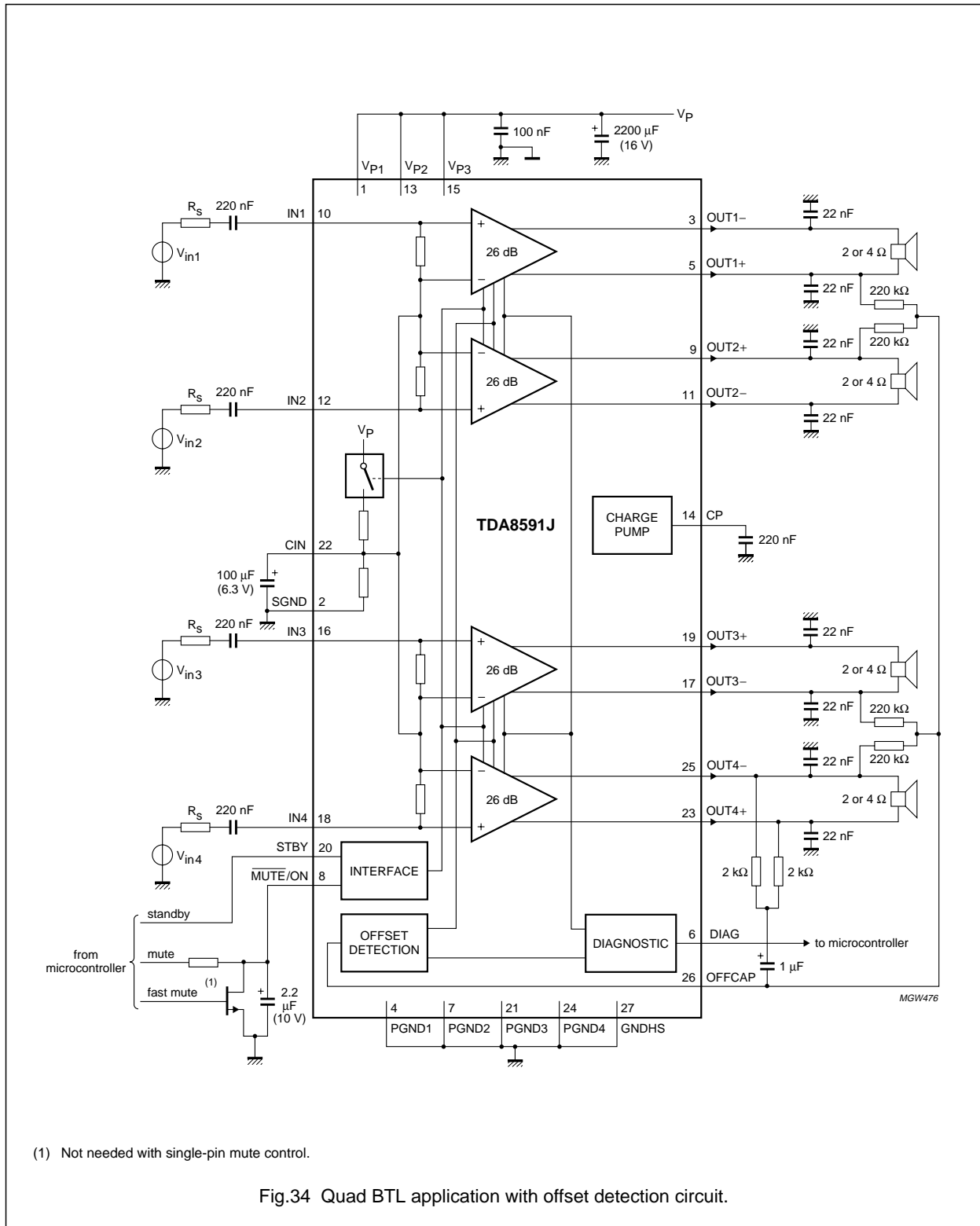

4 × 44 W into 4 Ω or 4 × 75 W into 2 Ω quad BTL car radio power amplifier

TDA8591J

14.1 Special attention for SMD input capacitors

When SMD capacitors are used as input capacitors, low frequency noise can occur due to stress on the PCB. The SMD capacitors can operate like small microphones with sensitivity of $\frac{1}{4}$. Special attention should be paid to this issue when selecting SMD capacitors at the four inputs (MKT capacitors are recommended).

14.2 Capacitors on outputs

The TDA8591J is optimized for a capacitor of 22 nF from each output to ground for RF immunity and ESD. These capacitors can be replaced by the capacitors on the connector block.

14.3 EMC precautions

The TDA8591J has an all N-type DMOS output stage. The main advantage of having the same type of power transistors in the output stage is symmetrical behaviour for positive and negative signals (sound quality).

A charge pump (DC to DC converter with capacitors only) is used to generate a voltage above the battery voltage to drive the high-side power. The clock frequency of the charge pump (2.9 MHz) is chosen above the AM frequency band. To prevent possible crosstalk in the FM frequency band, a SIL pad can be used between the rear of the TDA8591J and the heatsink. This SIL pad is an electrical isolator and thermal conductor. It is advisable to connect the power supply lines of the TDA8591J directly to the power supply on the printed circuit board of the radio, so that a one-point earth bonding with the tuner supply is achieved.

The external capacitor of the charge pump (connected to pin CP) filters and buffers the voltage generated internally.

14.6 Detection of short-circuits

Table 3 Detection of short-circuits in standby, mute and operating modes.

AMPLIFIER MODE	SHORT-CIRCUIT ACROSS LOAD	SHORT-CIRCUIT TO SUPPLY OR GROUND
Standby	no diagnosis	no diagnosis
Mute (no output signal)	the value of short-circuit that activates diagnosis and protection depends on the output offset voltage	no diagnosis and no active protection if short-circuit >100 Ω
Operating (output signal present)	diagnosis and active protection if short-circuit <0.4 Ω	no diagnosis and no active protection if short-circuit >100 Ω

The loop area of the capacitor connected to pins CP and PGND2 should be kept as small as possible. For optimum performance the capacitor used should have a good frequency performance, for example an SMD ceramic capacitor. See Figs 35 and 36 for a good PCB layout.

14.4 Offset detection

As shown in Fig.34, to obtain the DC offset information, an output from each bridge is summed and filtered through external 220 kΩ resistors and a 1 μF capacitor at pin OFFCAP. The low frequency roll-off can be chosen with the resistor/capacitor combination. Because of the random phase of the DC offset voltage, the capacitor on pin OFFCAP should not be a conventional electrolytic capacitor as leakage current in this capacitor would cause a shift in low frequency roll-off because of no pre-biasing.

If the offset detection is not used, pin OFFCAP can be connected to ground, the external components (resistors of 220 kΩ and 2 kΩ and the capacitor of 1 μF) are not needed and the circuit is as shown in Fig.33.

14.5 Channel selection

The following recommendation for a four channel application is given on the basis of the results of the channel separation measurements and the dissipation spread within the package:

- Front-left = OUT1
- Rear-left = OUT2
- Rear-right = OUT3
- Front-right = OUT4.

$4 \times 44 \text{ W}$ into 4Ω or $4 \times 75 \text{ W}$ into 2Ω
quad BTL car radio power amplifier

TDA8591J

14.7 PCB layout

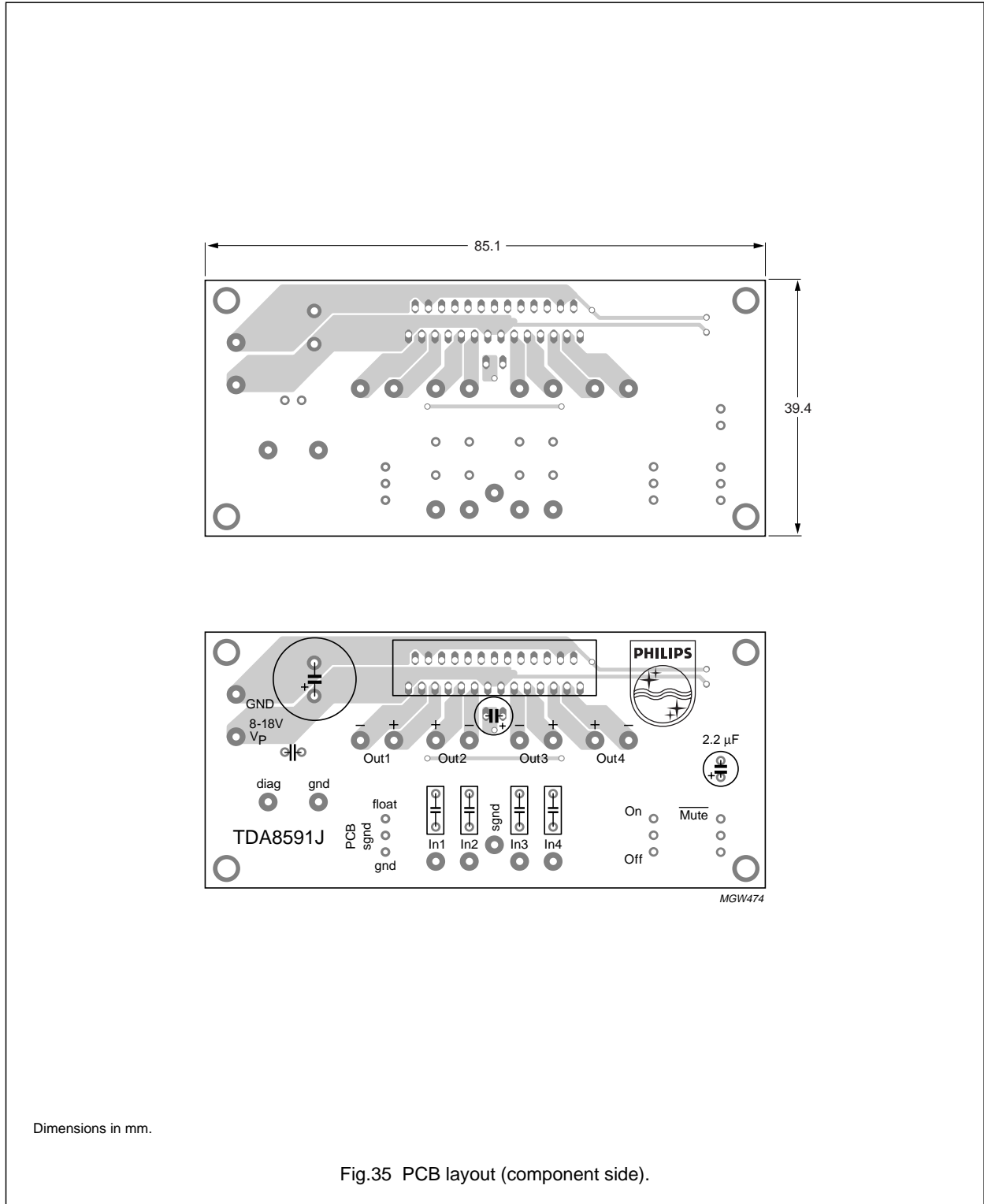

$4 \times 44 \text{ W}$ into 4Ω or $4 \times 75 \text{ W}$ into 2Ω
quad BTL car radio power amplifier

TDA8591J

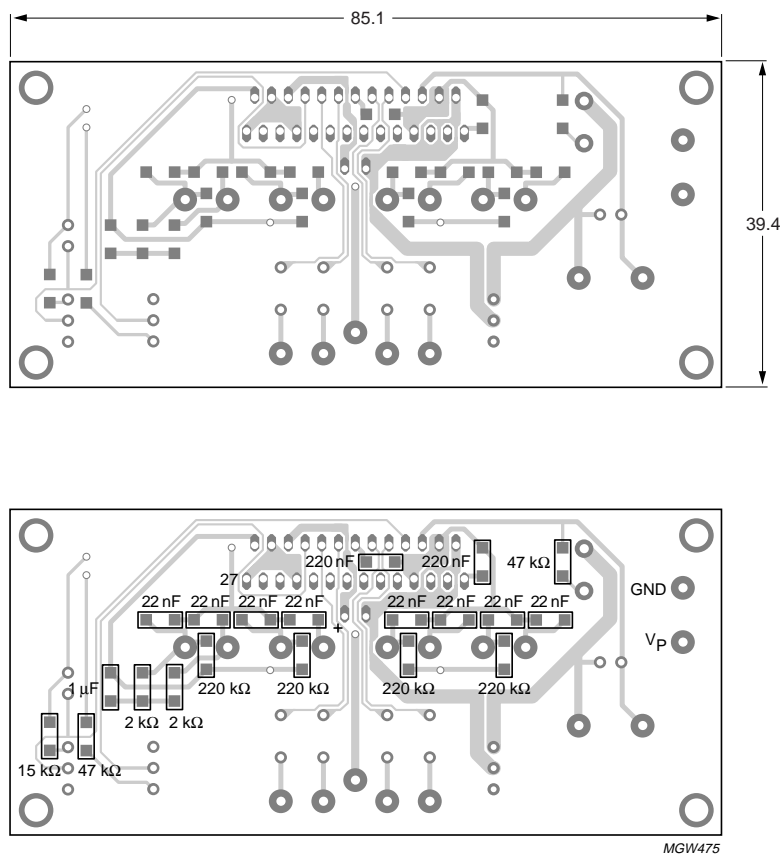

MGW475

Dimensions in mm.

Fig.36 PCB layout (soldering side).

4 × 44 W into 4 Ω or 4 × 75 W into 2 Ω quad BTL car radio power amplifier

TDA8591J

14.8 PCB design advice

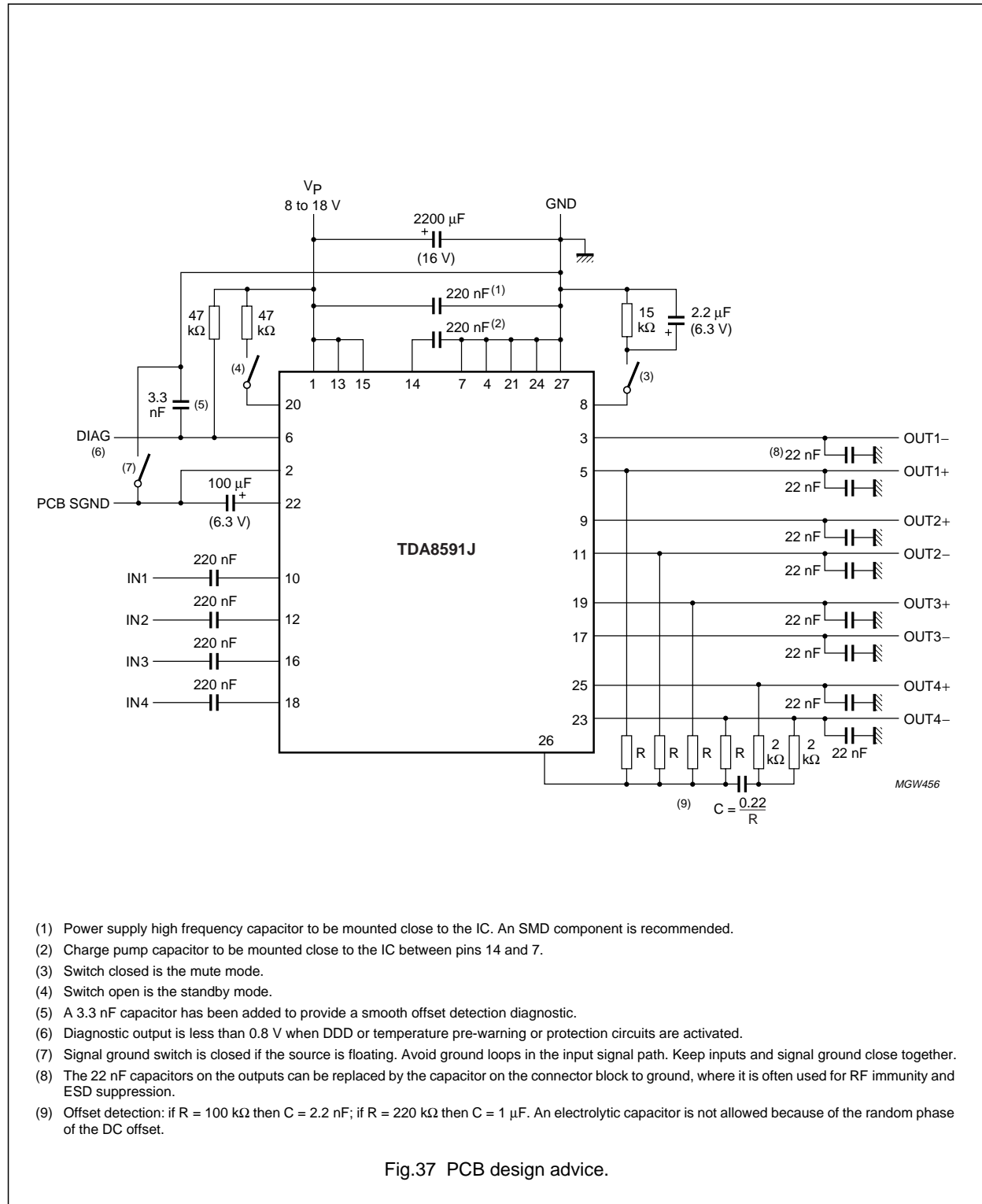

Fig.37 PCB design advice.

4 × 44 W into 4 Ω or 4 × 75 W into 2 Ω
quad BTL car radio power amplifier

TDA8591J

15 PACKAGE OUTLINE

DBS27P: plastic DIL-bent-SIL power package; 27 leads (lead length 7.7 mm)

SOT521-1

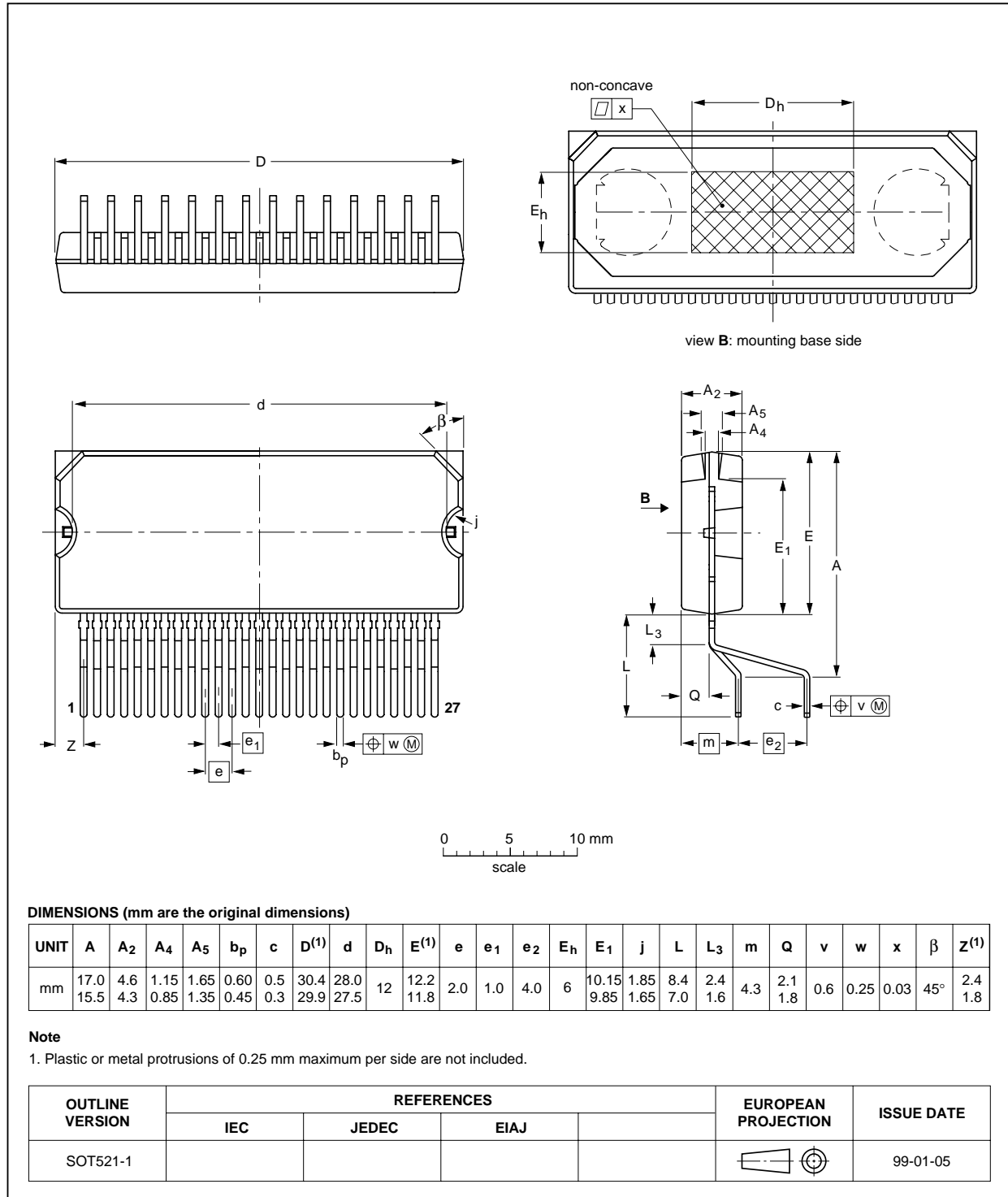

4 × 44 W into 4 Ω or 4 × 75 W into 2 Ω quad BTL car radio power amplifier

TDA8591J

16 SOLDERING

16.1 Introduction to soldering through-hole mount packages

This text gives a brief insight to wave, dip and manual soldering. A more in-depth account of soldering ICs can be found in our "Data Handbook IC26; Integrated Circuit Packages" (document order number 9398 652 90011).

Wave soldering is the preferred method for mounting of through-hole mount IC packages on a printed-circuit board.

16.2 Soldering by dipping or by solder wave

The maximum permissible temperature of the solder is 260 °C; solder at this temperature must not be in contact with the joints for more than 5 seconds.

16.4 Suitability of through-hole mount IC packages for dipping and wave soldering methods

PACKAGE	SOLDERING METHOD	
	DIPPING	WAVE
DBS, DIP, HDIP, SDIP, SIL	suitable	suitable ⁽¹⁾

Note

- For SDIP packages, the longitudinal axis must be parallel to the transport direction of the printed-circuit board.

The total contact time of successive solder waves must not exceed 5 seconds.

The device may be mounted up to the seating plane, but the temperature of the plastic body must not exceed the specified maximum storage temperature ($T_{stg(max)}$). If the printed-circuit board has been pre-heated, forced cooling may be necessary immediately after soldering to keep the temperature within the permissible limit.

16.3 Manual soldering

Apply the soldering iron (24 V or less) to the lead(s) of the package, either below the seating plane or not more than 2 mm above it. If the temperature of the soldering iron bit is less than 300 °C it may remain in contact for up to 10 seconds. If the bit temperature is between 300 and 400 °C, contact may be up to 5 seconds.

4 × 44 W into 4 Ω or 4 × 75 W into 2 Ω quad BTL car radio power amplifier

TDA8591J

17 DATA SHEET STATUS

DATA SHEET STATUS ⁽¹⁾	PRODUCT STATUS ⁽²⁾	DEFINITIONS
Objective data	Development	This data sheet contains data from the objective specification for product development. Philips Semiconductors reserves the right to change the specification in any manner without notice.
Preliminary data	Qualification	This data sheet contains data from the preliminary specification. Supplementary data will be published at a later date. Philips Semiconductors reserves the right to change the specification without notice, in order to improve the design and supply the best possible product.
Product data	Production	This data sheet contains data from the product specification. Philips Semiconductors reserves the right to make changes at any time in order to improve the design, manufacturing and supply. Changes will be communicated according to the Customer Product/Process Change Notification (CPCN) procedure SNW-SQ-650A.

Notes

1. Please consult the most recently issued data sheet before initiating or completing a design.
2. The product status of the device(s) described in this data sheet may have changed since this data sheet was published. The latest information is available on the Internet at URL <http://www.semiconductors.philips.com>.

18 DEFINITIONS

Short-form specification — The data in a short-form specification is extracted from a full data sheet with the same type number and title. For detailed information see the relevant data sheet or data handbook.

Limiting values definition — Limiting values given are in accordance with the Absolute Maximum Rating System (IEC 60134). Stress above one or more of the limiting values may cause permanent damage to the device.

These are stress ratings only and operation of the device at these or at any other conditions above those given in the Characteristics sections of the specification is not implied. Exposure to limiting values for extended periods may affect device reliability.

Application information — Applications that are described herein for any of these products are for illustrative purposes only. Philips Semiconductors make no representation or warranty that such applications will be suitable for the specified use without further testing or modification.

19 DISCLAIMERS

Life support applications — These products are not designed for use in life support appliances, devices, or systems where malfunction of these products can reasonably be expected to result in personal injury. Philips Semiconductors customers using or selling these products for use in such applications do so at their own risk and agree to fully indemnify Philips Semiconductors for any damages resulting from such application.

Right to make changes — Philips Semiconductors reserves the right to make changes, without notice, in the products, including circuits, standard cells, and/or software, described or contained herein in order to improve design and/or performance. Philips Semiconductors assumes no responsibility or liability for the use of any of these products, conveys no licence or title under any patent, copyright, or mask work right to these products, and makes no representations or warranties that these products are free from patent, copyright, or mask work right infringement, unless otherwise specified.

$4 \times 44 \text{ W}$ into 4Ω or $4 \times 75 \text{ W}$ into 2Ω
quad BTL car radio power amplifier

TDA8591J

NOTES

$4 \times 44 \text{ W}$ into 4Ω or $4 \times 75 \text{ W}$ into 2Ω
quad BTL car radio power amplifier

TDA8591J

NOTES

Philips Semiconductors – a worldwide company

Contact information

For additional information please visit <http://www.semiconductors.philips.com>. Fax: **+31 40 27 24825**

For sales offices addresses send e-mail to: sales.addresses@www.semiconductors.philips.com.

© Koninklijke Philips Electronics N.V. 2002

SCA74

All rights are reserved. Reproduction in whole or in part is prohibited without the prior written consent of the copyright owner.

The information presented in this document does not form part of any quotation or contract, is believed to be accurate and reliable and may be changed without notice. No liability will be accepted by the publisher for any consequence of its use. Publication thereof does not convey nor imply any license under patent- or other industrial or intellectual property rights.

Printed in The Netherlands

753503/01/pp36

Date of release: 2002 Jan 14

Document order number: 9397 750 08682

Let's make things better.

**Philips
Semiconductors**



PHILIPS