

# DATA SHEET



## **TDA8735** PLL frequency synthesizer

Product specification  
Supersedes data of September 1994  
File under Integrated Circuits, IC01

1998 Oct 23

## PLL frequency synthesizer

## TDA8735

### FEATURES

- Complete 30 MHz single-chip tuning system
- Loop amplifier included
- 2-level current amplifier (charge pump) for adjusting the loop gain
- A powerful digital memory phase detector
- Programmable reference frequencies of 1 kHz, 10 kHz or 25 kHz
- I<sup>2</sup>C-bus interface
- Programmable address select input
- Software controlled switch output.

### APPLICATIONS

- Satellite sound receiver
- Radio receiver: LW, MW and SW.



### GENERAL DESCRIPTION

The TDA8735 is a single-chip PLL synthesizer designed for satellite receivers. The device can be set to two different addresses which can be used in applications where independently tuned VCOs are required.

To adapt to different frequency accuracy, 3 reference frequencies are selectable via the I<sup>2</sup>C-bus. The charge pump current can be set to 2 values with a ratio of 1 : 100 via the I<sup>2</sup>C-bus.

A programmable switch (open-collector) is integrated to enable mode or normal switching, or other types of application.

### QUICK REFERENCE DATA

SYMBOL	PARAMETER	CONDITIONS	MIN.	TYP.	MAX.	UNIT
V <sub>CC1</sub>	supply voltage (pin 3)		4.5	5.0	5.5	V
V <sub>CC2</sub>	supply voltage (pin 16)		V <sub>CC1</sub>	8.5	12	V
I <sub>CC1</sub>	supply current (pin 3)	outputs unloaded	12	20	28	mA
I <sub>CC2</sub>	supply current (pin 16)	outputs unloaded	0.2	0.5	1	mA
f <sub>i(max)</sub>	maximum input frequency		30	–	–	MHz
f <sub>i(min)</sub>	minimum input frequency		–	–	512	kHz
V <sub>i(rms)</sub>	input voltage (RMS value)		30	–	500	mV
P <sub>tot</sub>	total power dissipation		–	0.14	–	W
T <sub>amb</sub>	operating ambient temperature		–30	–	+85	°C

### ORDERING INFORMATION

TYPE NUMBER	PACKAGE		
	NAME	DESCRIPTION	VERSION
TDA8735	DIP16	plastic dual in-line package; 16 leads (300 mil); long body	SOT38-1
TDA8735T	SO16	plastic small outline package; 16 leads; body width 7.5 mm	SOT162-1

PLL frequency synthesizer

TDA8735

BLOCK DIAGRAM

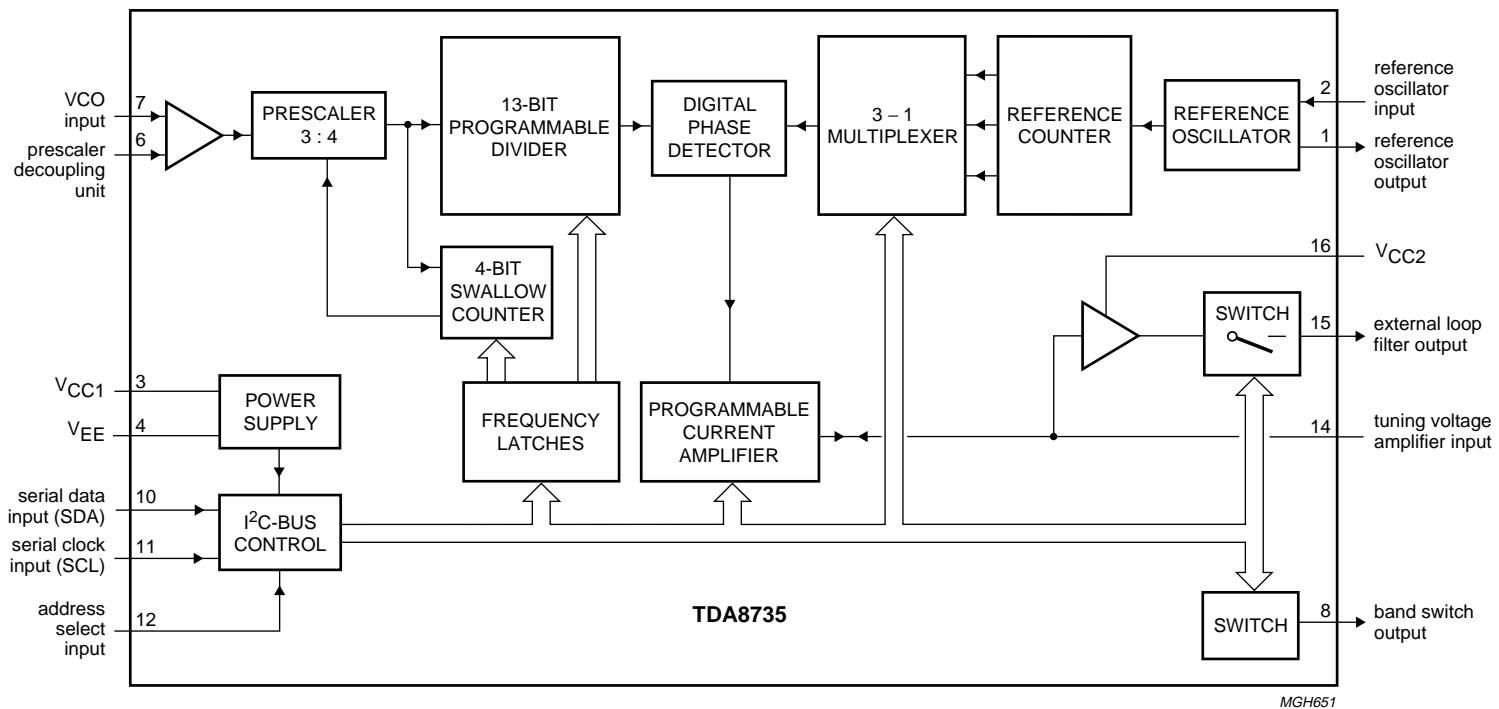

Fig.1 Block diagram.

## PLL frequency synthesizer

## TDA8735

## PINNING

SYMBOL	PIN	DESCRIPTION
XTAL1	1	reference oscillator output
XTAL2	2	reference oscillator input
V <sub>CC1</sub>	3	supply voltage 1
V <sub>EE</sub>	4	ground
n.c.	5	not connected
DEC	6	prescaler decoupling
VCOFI	7	VCO input frequency
BS	8	band switch output
n.c.	9	not connected
SDA	10	serial data input (I <sup>2</sup> C-bus)
SCL	11	serial clock input (I <sup>2</sup> C-bus)
AS	12	address select input (I <sup>2</sup> C-bus)
n.c.	13	not connected
LOOP <sub>I</sub>	14	tuning voltage amplifier input
LOOP <sub>O</sub>	15	external loop filter output
V <sub>CC2</sub>	16	supply voltage 2

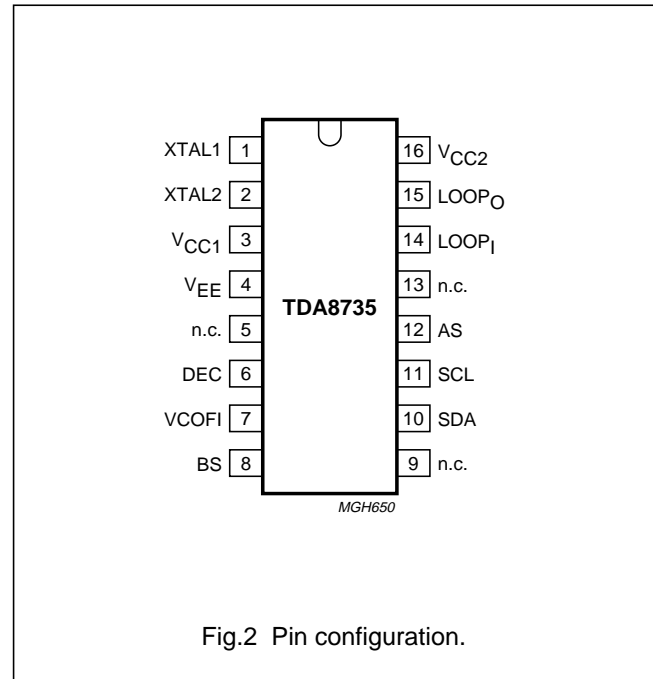

Fig.2 Pin configuration.

## FUNCTIONAL DESCRIPTION

The TDA8735 contains the following parts and facilities:

- Input amplifier VCO signal
- A prescaler with the divisors 3 : 4 and a 2-bit programmable swallow counter
- A 13-bit programmable counter
- A digital memory phase detector
- A reference frequency channel comprised of a 4 MHz crystal oscillator followed by a reference counter; the reference frequency can be 1, 10 or 25 kHz and is applied to the digital memory phase detector
- An I<sup>2</sup>C-bus interface with data latches and control logic; the I<sup>2</sup>C-bus is intended for communication between microcontrollers and different ICs or modules. Detailed information on the I<sup>2</sup>C-bus specification is available on request.
- A software-controlled switch output
- A programmable current amplifier (charge pump) which consists of a 5 and a 500  $\mu$ A current source, this allows adjustment of loop gain, thus providing high-current high-speed tuning and low current-stable tuning. The output at the loop amplifier can deliver a tuning voltage of up to 10.5 V ( $V_{CC2} - 1.5$  V).

## Controls

The TDA8735 is controlled via the 2-wire I<sup>2</sup>C-bus. As slave receiver for programming there is one module address, a logic 0 ( $R/\overline{W}$  bit), a subaddress byte and four data bytes. The subaddress determines which one of the four data bytes is transmitted first. The module address contains a programmable address bit (D1) which with address select input AS (pin 12) makes it possible to operate two TDA8735 in one system.

The auto increment facility of the I<sup>2</sup>C-bus allows programming of the TDA8735 within one transmission (address + subaddress + 4 data bytes).

The TDA8735 can also be partially programmed. Transmission must then be ended by a stop condition.

The bit organization of the 4 data bytes is illustrated in Fig.3 and is described below.

The divider number is defined by 15-bit words, bits S0 to S14. To calculate the lock frequency, the divider number has to be multiplied by the selected reference frequency.

PLL frequency synthesizer

TDA8735

**Table 1** Divider number setting; note 1

ON	DIVIDER NUMBER SETTING	INPUT
0	$(S0 + S1) \times 2^1$ to $+ S13 \times 2^{13} + S14 \times 2^{14}$	ON

**Note**

1. Where the minimum divider ratio is:  $2^6 = 64$  to  $2^{15} - 1 = 32761$ .

**Table 2** Bit CP (used to control the charge pump; DB0 : D0)

CP	CURRENT
0	LOW
1	HIGH

**Table 3** Bits REF1 and REF2 (used to set the reference frequency applied to the phase detector; DB2 : D7 and D6)

REF1	REF2	FREQUENCY (kHz)
0	0	1
0	1	10
1	0	25
1	1	0

**Table 4** Bit OPAMP (used to control the switch in the tuning voltage amplifier output circuitry; DB2 : D4)

OPAMP	SWITCH
1	on
0	off

**Table 5** Bit BS (used to control the open-collector switch output; DB2 : D2)

BS	SWITCH OUTPUT
1	sink current
0	floating

The data byte DB3 must be set to 0 to 0. It is also used for test purposes (see Fig.3).

PLL frequency synthesizer

TDA8735

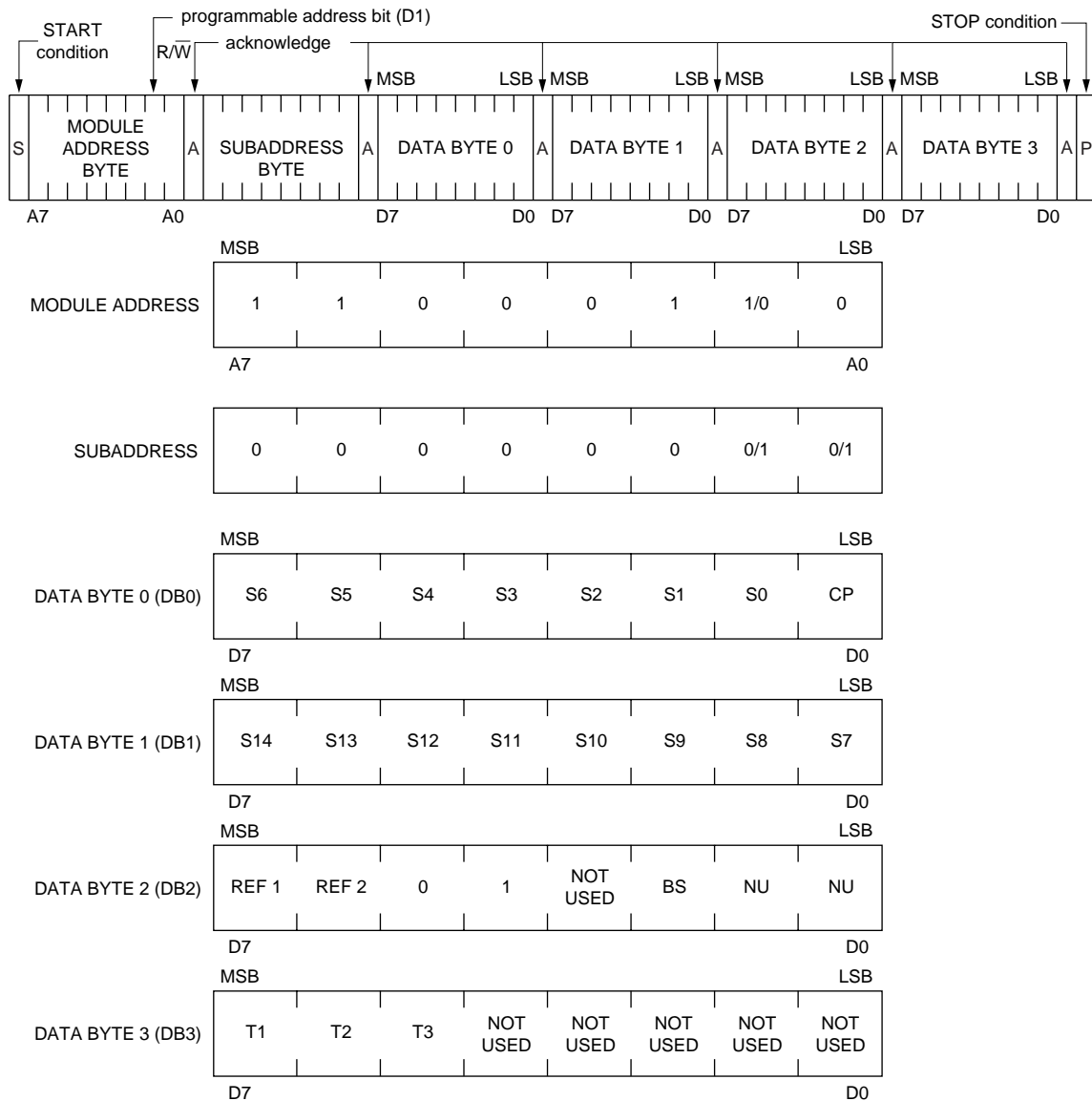

examples using auto-increment facility

S	ADDRESS	A	SUBADDRESS	02	A	DB2	A	DB3	A	P
---	---------	---	------------	----	---	-----	---	-----	---	---

S	ADDRESS	A	SUBADDRESS	00	A	DB0	A	DB1	A	P
---	---------	---	------------	----	---	-----	---	-----	---	---

S	ADDRESS	A	SUBADDRESS	03	A	DB3	A	DB0	A	DB1	A	DB2	A	P
---	---------	---	------------	----	---	-----	---	-----	---	-----	---	-----	---	---

MGL509

Fig.3 Bit organization.

## PLL frequency synthesizer

TDA8735

**LIMITING VALUES**

In accordance with the Absolute Maximum Rating System (IEC 134).

SYMBOL	PARAMETER	MIN.	MAX.	UNIT
V <sub>CC1</sub>	supply voltage (pin 3)	-0.3	+5.5	V
V <sub>CC2</sub>	supply voltage (pin 16)	V <sub>CC1</sub>	12.5	V
P <sub>tot</sub>	total power dissipation	-	0.85	W
T <sub>amb</sub>	operating ambient temperature	-30	+85	°C
T <sub>stg</sub>	storage temperature	-65	+150	°C

**HANDLING**

Every pin withstands the ESD test in accordance with "MIL-STD-883C category B" (2000 V).

**CHARACTERISTICS**V<sub>CC1</sub> = 5 V; V<sub>CC2</sub> = 8.5 V; T<sub>amb</sub> = 25 °C; unless otherwise specified.

SYMBOL	PARAMETER	CONDITIONS	MIN.	TYP.	MAX.	UNIT
<b>Supplies</b>						
V <sub>CC1</sub>	supply voltage (pin 3)		4.5	5.0	5.5	V
V <sub>CC2</sub>	supply voltage (pin 16)		V <sub>CC1</sub>	8.5	12	V
I <sub>CC1</sub>	supply current (pin 3)	no outputs loaded	12	20	28	mA
I <sub>CC2</sub>	supply current (pin 16)	no outputs loaded	0.2	0.5	1	mA
		TDA8735T only	0.7	1	1.5	mA
<b>I<sup>2</sup>C-bus inputs (SDA and SCL)</b>						
V <sub>IH</sub>	HIGH-level input voltage		3.0	-	5.0	V
V <sub>IL</sub>	LOW-level input voltage		-0.3	-	+1.5	V
I <sub>IH</sub>	HIGH-level input current		-	-	10	μA
I <sub>IL</sub>	LOW-level input current		-	-	10	μA
<b>SDA output</b>						
V <sub>OL</sub>	LOW-level output voltage	open-collector; I <sub>OL</sub> = 3.0 mA	-	-	0.4	V
<b>AS input</b>						
V <sub>IH</sub>	HIGH-level input voltage	AS = C6	3.0	-	5.0	V
V <sub>IL</sub>	LOW-level input voltage	AS = C4	-0.3	-	+1.0	V
I <sub>IH</sub>	HIGH-level input current		-	-	10	μA
I <sub>IL</sub>	LOW-level input current		-	-	10	μA
<b>RF input</b>						
f <sub>i(max)</sub>	maximum input frequency		30	-	-	MHz
f <sub>i(min)</sub>	minimum input frequency		-	-	512	kHz
V <sub>i(rms)</sub>	input voltage (RMS value)	measured in Fig.4	30	-	500	mV
R <sub>i</sub>	input resistance		-	5.9	-	kΩ
C <sub>i</sub>	input capacitance		-	2	-	pF

## PLL frequency synthesizer

## TDA8735

SYMBOL	PARAMETER	CONDITIONS	MIN.	TYP.	MAX.	UNIT
<b>Oscillator (XTAL1 and XTAL2)</b>						
R <sub>xtal</sub>	crystal resonance resistance (4 MHz)	see Fig.5	–	–	150	Ω
<b>Programmable charge pump</b>						
I <sub>CHP</sub>	output current to loop filter	bit CP logic 0 logic 1 logic 0; TDA8735T only	3 400 3	5 500 5	7 600 9	μA μA μA
<b>Ripple rejection</b>						
RR	$20\log\frac{\Delta V_{CC1}}{\Delta V_O}$	f <sub>ripple</sub> = 100 Hz	40	50	–	dB
	$20\log\frac{\Delta V_{CC2}}{\Delta V_O}$	f <sub>ripple</sub> = 100 Hz	40	50	–	dB
<b>Band switch output (pin 8)</b>						
V <sub>OH</sub>	HIGH-level output voltage		–	–	12	V
V <sub>OL</sub>	LOW-level output voltage	I <sub>OL</sub> = 3 mA	–	–	0.8	V
I <sub>LO</sub>	output leakage current	V <sub>OH</sub> = 12 V	–	–	10	μA
<b>Tuning voltage amplifier output (pin 15)</b>						
V <sub>o(max)</sub>	maximum output voltage	I <sub>source</sub> = 0.5 mA	V <sub>CC2</sub> – 1.5	–	–	V
V <sub>o(min)</sub>	minimum output voltage	I <sub>sink</sub> = 1 mA	–	–	0.8	V
I <sub>source</sub>	maximum output source current		0.5	–	–	mA
I <sub>sink</sub>	maximum output sink current		1.0	–	–	mA
Z <sub>o(off)</sub>	impedance of switched off output		5	–	–	MΩ
I <sub>bias</sub>	input bias current (absolute value)		–	1	5	nA



PLL frequency synthesizer

TDA8735

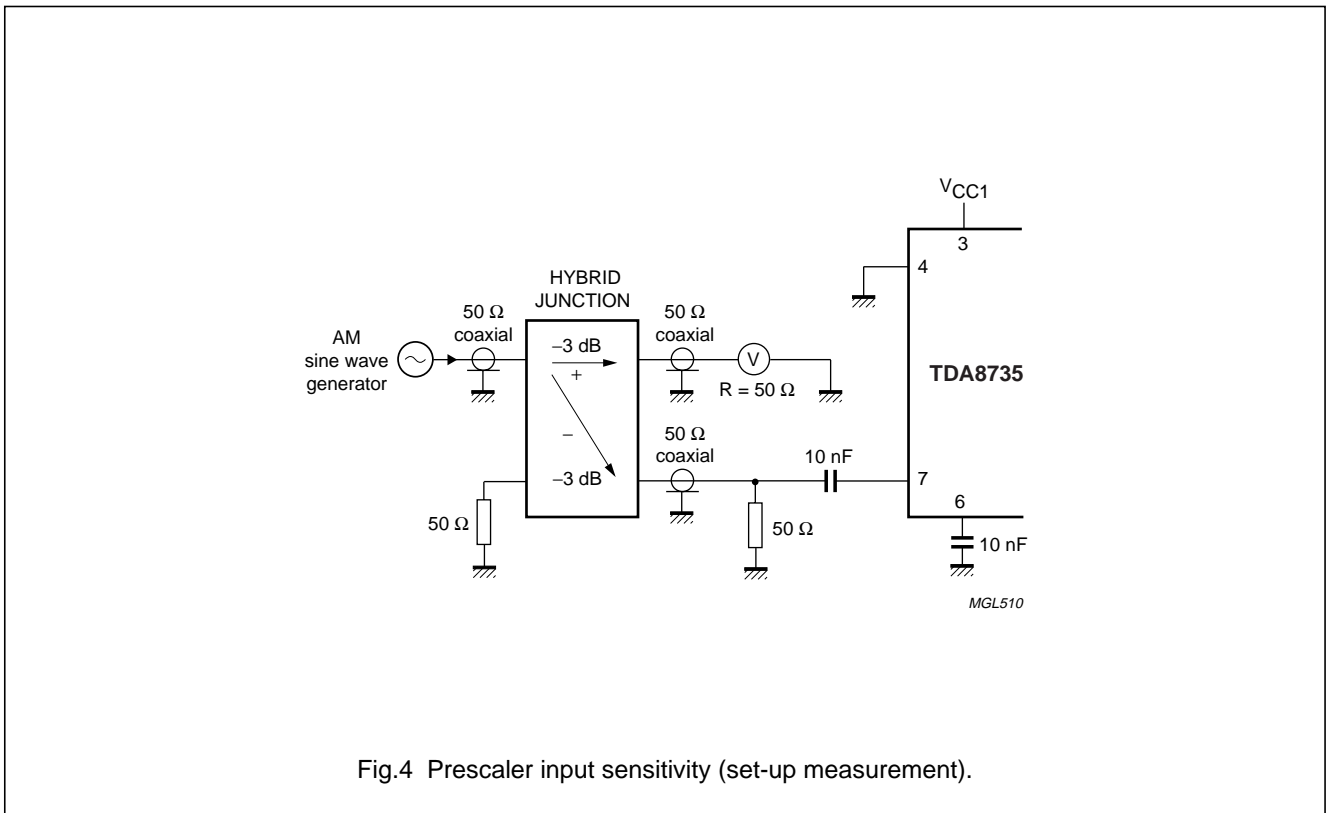

Fig.4 Prescaler input sensitivity (set-up measurement).

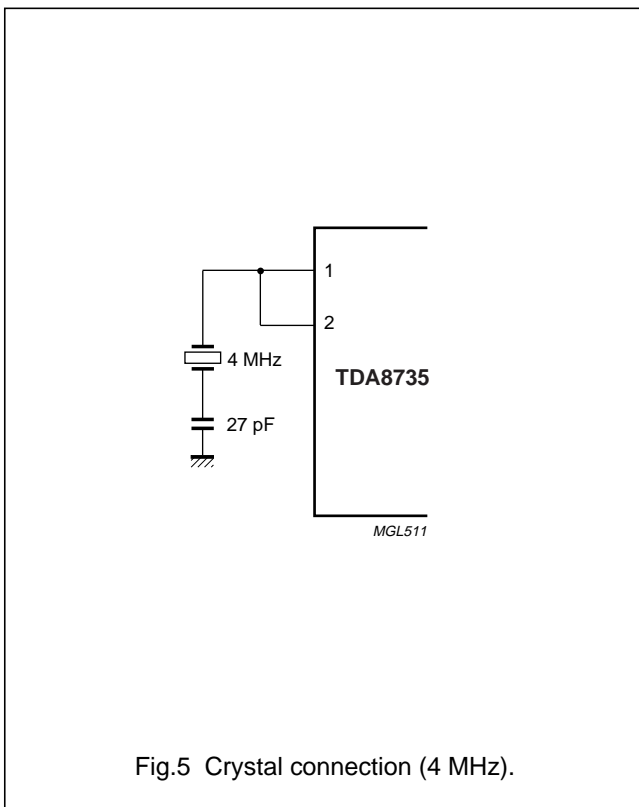
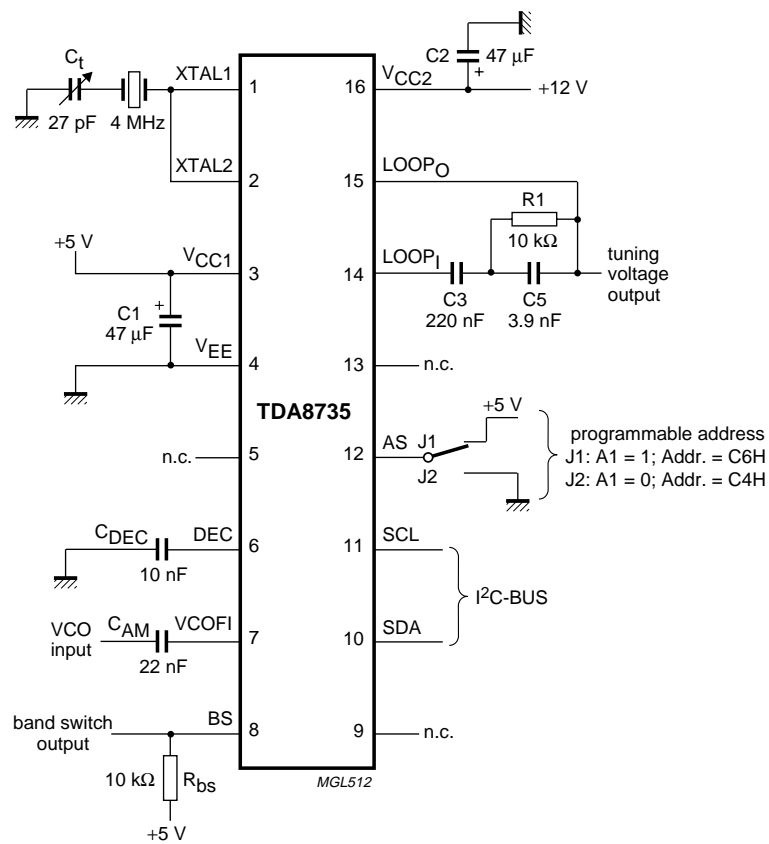

Fig.5 Crystal connection (4 MHz).

PLL frequency synthesizer

TDA8735

APPLICATION INFORMATION



Loop filter depends on VCO parameters.

Fig.6 Application example.

PLL frequency synthesizer

TDA8735

PACKAGE OUTLINES

DIP16: plastic dual in-line package; 16 leads (300 mil); long body

SOT38-1

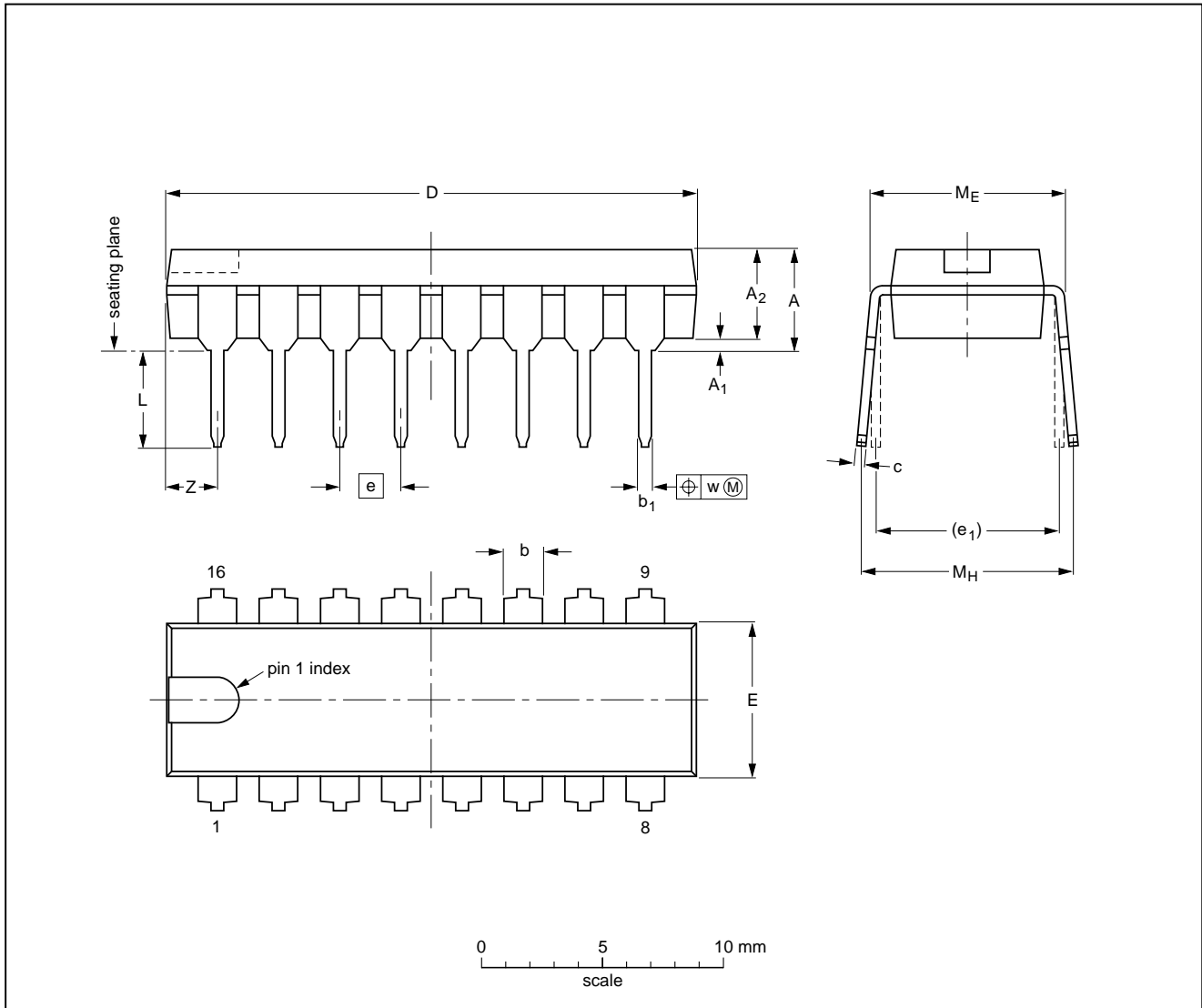

DIMENSIONS (inch dimensions are derived from the original mm dimensions)

UNIT	A max.	A <sub>1</sub> min.	A <sub>2</sub> max.	b	b <sub>1</sub>	c	D <sup>(1)</sup>	E <sup>(1)</sup>	e	e <sub>1</sub>	L	M <sub>E</sub>	M <sub>H</sub>	w	Z <sup>(1)</sup> max.
mm	4.7	0.51	3.7	1.40 1.14	0.53 0.38	0.32 0.23	21.8 21.4	6.48 6.20	2.54	7.62	3.9 3.4	8.25 7.80	9.5 8.3	0.254	2.2
inches	0.19	0.020	0.15	0.055 0.045	0.021 0.015	0.013 0.009	0.86 0.84	0.26 0.24	0.10	0.30	0.15 0.13	0.32 0.31	0.37 0.33	0.01	0.087

Note

1. Plastic or metal protrusions of 0.25 mm maximum per side are not included.

OUTLINE VERSION	REFERENCES				EUROPEAN PROJECTION	ISSUE DATE
	IEC	JEDEC	EIAJ			
SOT38-1	050G09	MO-001AE				92-10-02 95-01-19

PLL frequency synthesizer

TDA8735

SO16: plastic small outline package; 16 leads; body width 7.5 mm

SOT162-1

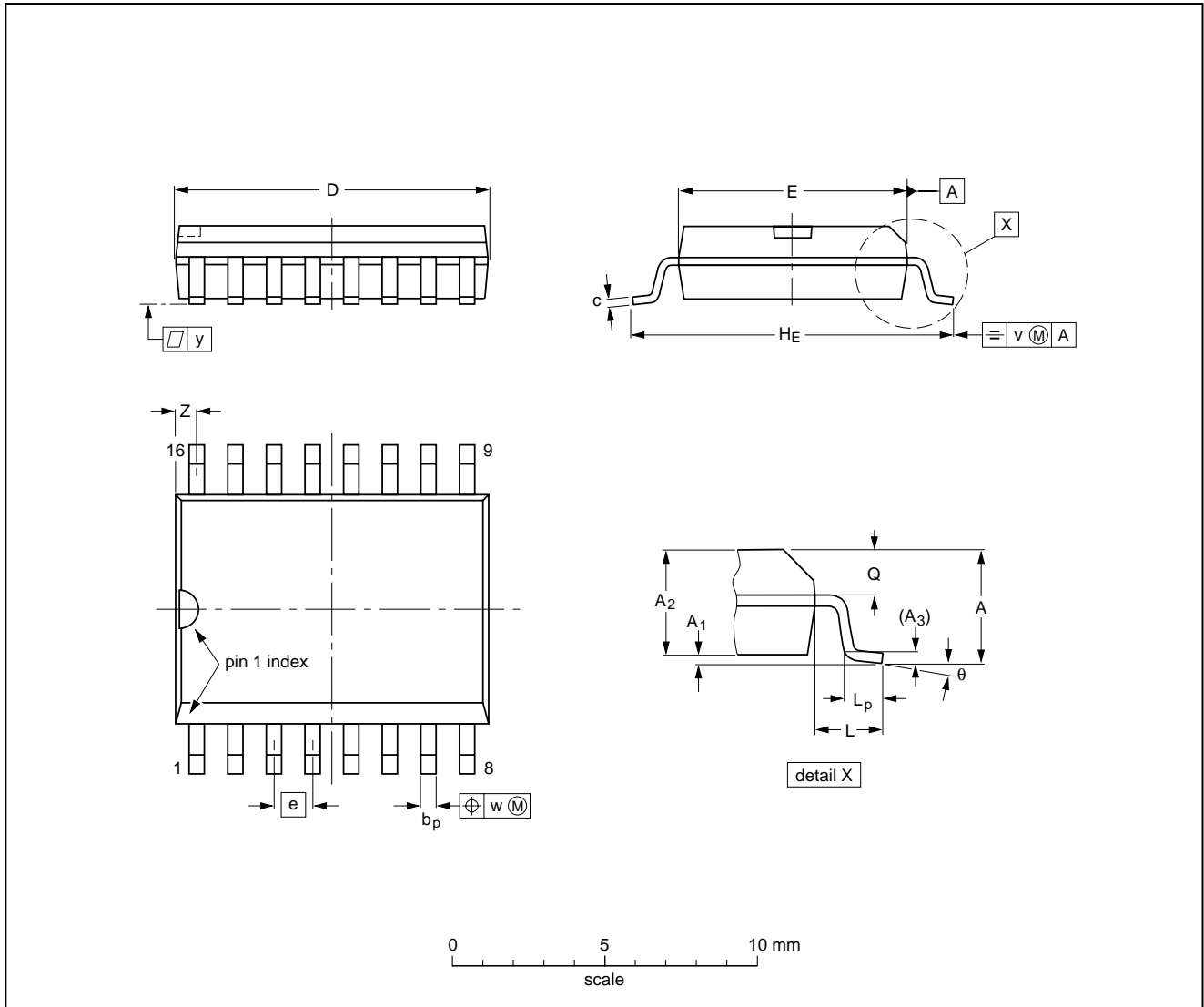

DIMENSIONS (inch dimensions are derived from the original mm dimensions)

UNIT	A max.	A <sub>1</sub>	A <sub>2</sub>	A <sub>3</sub>	b <sub>p</sub>	c	D <sup>(1)</sup>	E <sup>(1)</sup>	e	H <sub>E</sub>	L	L <sub>p</sub>	Q	v	w	y	Z <sup>(1)</sup>	θ
mm	2.65	0.30 0.10	2.45 2.25	0.25	0.49 0.36	0.32 0.23	10.5 10.1	7.6 7.4	1.27	10.65 10.00	1.4	1.1 0.4	1.1 1.0	0.25	0.25	0.1	0.9 0.4	8° 0°
inches	0.10	0.012 0.004	0.096 0.089	0.01	0.019 0.014	0.013 0.009	0.41 0.40	0.30 0.29	0.050	0.419 0.394	0.055	0.043 0.016	0.043 0.039	0.01	0.01	0.004	0.035 0.016	

Note

1. Plastic or metal protrusions of 0.15 mm maximum per side are not included.

OUTLINE VERSION	REFERENCES				EUROPEAN PROJECTION	ISSUE DATE
	IEC	JEDEC	EIAJ			
SOT162-1	075E03	MS-013AA				95-01-24 97-05-22

## PLL frequency synthesizer

TDA8735

### SOLDERING

#### Introduction

There is no soldering method that is ideal for all IC packages. Wave soldering is often preferred when through-hole and surface mounted components are mixed on one printed-circuit board. However, wave soldering is not always suitable for surface mounted ICs, or for printed-circuits with high population densities. In these situations reflow soldering is often used.

This text gives a very brief insight to a complex technology. A more in-depth account of soldering ICs can be found in our *"Data Handbook IC26; Integrated Circuit Packages"* (order code 9398 652 90011).

#### DIP

##### SOLDERING BY DIPPING OR BY WAVE

The maximum permissible temperature of the solder is 260 °C; solder at this temperature must not be in contact with the joint for more than 5 seconds. The total contact time of successive solder waves must not exceed 5 seconds.

The device may be mounted up to the seating plane, but the temperature of the plastic body must not exceed the specified maximum storage temperature ( $T_{stg\ max}$ ). If the printed-circuit board has been pre-heated, forced cooling may be necessary immediately after soldering to keep the temperature within the permissible limit.

##### REPAIRING SOLDERED JOINTS

Apply a low voltage soldering iron (less than 24 V) to the lead(s) of the package, below the seating plane or not more than 2 mm above it. If the temperature of the soldering iron bit is less than 300 °C it may remain in contact for up to 10 seconds. If the bit temperature is between 300 and 400 °C, contact may be up to 5 seconds.

#### SO

##### REFLOW SOLDERING

Reflow soldering techniques are suitable for all SO packages.

Reflow soldering requires solder paste (a suspension of fine solder particles, flux and binding agent) to be applied to the printed-circuit board by screen printing, stencilling or pressure-syringe dispensing before package placement.

Several techniques exist for reflowing; for example, thermal conduction by heated belt. Dwell times vary between 50 and 300 seconds depending on heating method. Typical reflow temperatures range from 215 to 250 °C.

Preheating is necessary to dry the paste and evaporate the binding agent. Preheating duration: 45 minutes at 45 °C.

##### WAVE SOLDERING

Wave soldering techniques can be used for all SO packages if the following conditions are observed:

- A double-wave (a turbulent wave with high upward pressure followed by a smooth laminar wave) soldering technique should be used.
- The longitudinal axis of the package footprint must be parallel to the solder flow.
- The package footprint must incorporate solder thieves at the downstream end.

During placement and before soldering, the package must be fixed with a droplet of adhesive. The adhesive can be applied by screen printing, pin transfer or syringe dispensing. The package can be soldered after the adhesive is cured.

Maximum permissible solder temperature is 260 °C, and maximum duration of package immersion in solder is 10 seconds, if cooled to less than 150 °C within 6 seconds. Typical dwell time is 4 seconds at 250 °C.

A mildly-activated flux will eliminate the need for removal of corrosive residues in most applications.

##### REPAIRING SOLDERED JOINTS

Fix the component by first soldering two diagonally-opposite end leads. Use only a low voltage soldering iron (less than 24 V) applied to the flat part of the lead. Contact time must be limited to 10 seconds at up to 300 °C. When using a dedicated tool, all other leads can be soldered in one operation within 2 to 5 seconds between 270 and 320 °C.

## PLL frequency synthesizer

TDA8735

**DEFINITIONS**

<b>Data sheet status</b>	
Objective specification	This data sheet contains target or goal specifications for product development.
Preliminary specification	This data sheet contains preliminary data; supplementary data may be published later.
Product specification	This data sheet contains final product specifications.
<b>Limiting values</b>	
Limiting values given are in accordance with the Absolute Maximum Rating System (IEC 134). Stress above one or more of the limiting values may cause permanent damage to the device. These are stress ratings only and operation of the device at these or at any other conditions above those given in the Characteristics sections of the specification is not implied. Exposure to limiting values for extended periods may affect device reliability.	
<b>Application information</b>	
Where application information is given, it is advisory and does not form part of the specification.	

**LIFE SUPPORT APPLICATIONS**

These products are not designed for use in life support appliances, devices, or systems where malfunction of these products can reasonably be expected to result in personal injury. Philips customers using or selling these products for use in such applications do so at their own risk and agree to fully indemnify Philips for any damages resulting from such improper use or sale.

**PURCHASE OF PHILIPS I<sup>2</sup>C COMPONENTS**

Purchase of Philips I<sup>2</sup>C components conveys a license under the Philips' I<sup>2</sup>C patent to use the components in the I<sup>2</sup>C system provided the system conforms to the I<sup>2</sup>C specification defined by Philips. This specification can be ordered using the code 9398 393 40011.

PLL frequency synthesizer

TDA8735

---

**NOTES**

# Philips Semiconductors – a worldwide company

**Argentina:** see South America

**Australia:** 34 Waterloo Road, NORTH RYDE, NSW 2113, Tel. +61 2 9805 4455, Fax. +61 2 9805 4466

**Austria:** Computerstr. 6, A-1101 WIEN, P.O. Box 213, Tel. +43 160 1010, Fax. +43 160 101 1210

**Belarus:** Hotel Minsk Business Center, Bld. 3, r. 1211, Volodarski Str. 6, 220050 MINSK, Tel. +375 172 200 733, Fax. +375 172 200 773

**Belgium:** see The Netherlands

**Brazil:** see South America

**Bulgaria:** Philips Bulgaria Ltd., Energoproject, 15th floor, 51 James Bourchier Blvd., 1407 SOFIA, Tel. +359 2 689 211, Fax. +359 2 689 102

**Canada:** PHILIPS SEMICONDUCTORS/COMPONENTS, Tel. +1 800 234 7381

**China/Hong Kong:** 501 Hong Kong Industrial Technology Centre, 72 Tat Chee Avenue, Kowloon Tong, HONG KONG, Tel. +852 2319 7888, Fax. +852 2319 7700

**Colombia:** see South America

**Czech Republic:** see Austria

**Denmark:** Prags Boulevard 80, PB 1919, DK-2300 COPENHAGEN S, Tel. +45 32 88 2636, Fax. +45 31 57 0044

**Finland:** Sinikalliontie 3, FIN-02630 ESPOO, Tel. +358 9 615800, Fax. +358 9 61580920

**France:** 51 Rue Carnot, BP317, 92156 SURESNES Cedex, Tel. +33 1 40 99 6161, Fax. +33 1 40 99 6427

**Germany:** Hammerbrookstraße 69, D-20097 HAMBURG, Tel. +49 40 23 53 60, Fax. +49 40 23 536 300

**Greece:** No. 15, 25th March Street, GR 17778 TAVROS/ATHENS, Tel. +30 1 4894 339/239, Fax. +30 1 4814 240

**Hungary:** see Austria

**India:** Philips INDIA Ltd, Band Box Building, 2nd floor, 254-D, Dr. Annie Besant Road, Worli, MUMBAI 400 025, Tel. +91 22 493 8541, Fax. +91 22 493 0966

**Indonesia:** PT Philips Development Corporation, Semiconductors Division, Gedung Philips, Jl. Buncit Raya Kav.99-100, JAKARTA 12510, Tel. +62 21 794 0040 ext. 2501, Fax. +62 21 794 0080

**Ireland:** Newstead, Clonskeagh, DUBLIN 14, Tel. +353 1 7640 000, Fax. +353 1 7640 200

**Israel:** RAPAC Electronics, 7 Kehilat Saloniki St, PO Box 18053, TEL AVIV 61180, Tel. +972 3 645 0444, Fax. +972 3 649 1007

**Italy:** PHILIPS SEMICONDUCTORS, Piazza IV Novembre 3, 20124 MILANO, Tel. +39 2 6752 2531, Fax. +39 2 6752 2557

**Japan:** Philips Bldg 13-37, Kohnan 2-chome, Minato-ku, TOKYO 108-8507, Tel. +81 3 3740 5130, Fax. +81 3 3740 5077

**Korea:** Philips House, 260-199 Itaewon-dong, Yongsan-ku, SEOUL, Tel. +82 2 709 1412, Fax. +82 2 709 1415

**Malaysia:** No. 76 Jalan Universiti, 46200 PETALING JAYA, SELANGOR, Tel. +60 3 750 5214, Fax. +60 3 757 4880

**Mexico:** 5900 Gateway East, Suite 200, EL PASO, TEXAS 79905, Tel. +9-5 800 234 7381

**Middle East:** see Italy

**Netherlands:** Postbus 90050, 5600 PB EINDHOVEN, Bldg. VB, Tel. +31 40 27 82785, Fax. +31 40 27 88399

**New Zealand:** 2 Wagener Place, C.P.O. Box 1041, AUCKLAND, Tel. +64 9 849 4160, Fax. +64 9 849 7811

**Norway:** Box 1, Manglerud 0612, OSLO, Tel. +47 22 74 8000, Fax. +47 22 74 8341

**Pakistan:** see Singapore

**Philippines:** Philips Semiconductors Philippines Inc., 106 Valero St. Salcedo Village, P.O. Box 2108 MCC, MAKATI, Metro MANILA, Tel. +63 2 816 6380, Fax. +63 2 817 3474

**Poland:** Ul. Lukiska 10, PL 04-123 WARSZAWA, Tel. +48 22 612 2831, Fax. +48 22 612 2327

**Portugal:** see Spain

**Romania:** see Italy

**Russia:** Philips Russia, Ul. Usatcheva 35A, 119048 MOSCOW, Tel. +7 095 755 6918, Fax. +7 095 755 6919

**Singapore:** Lorong 1, Toa Payoh, SINGAPORE 319762, Tel. +65 350 2538, Fax. +65 251 6500

**Slovakia:** see Austria

**Slovenia:** see Italy

**South Africa:** S.A. PHILIPS Pty Ltd., 195-215 Main Road Martindale, 2092 JOHANNESBURG, P.O. Box 7430 Johannesburg 2000, Tel. +27 11 470 5911, Fax. +27 11 470 5494

**South America:** Al. Vicente Pinzon, 173, 6th floor, 04547-130 SÃO PAULO, SP, Brazil, Tel. +55 11 821 2333, Fax. +55 11 821 2382

**Spain:** Balmes 22, 08007 BARCELONA, Tel. +34 93 301 6312, Fax. +34 93 301 4107

**Sweden:** Kottbygatan 7, Akalla, S-16485 STOCKHOLM, Tel. +46 8 5985 2000, Fax. +46 8 5985 2745

**Switzerland:** Allmendstrasse 140, CH-8027 ZÜRICH, Tel. +41 1 488 2741 Fax. +41 1 488 3263

**Taiwan:** Philips Semiconductors, 6F, No. 96, Chien Kuo N. Rd., Sec. 1, TAIPEI, Taiwan Tel. +886 2 2134 2865, Fax. +886 2 2134 2874

**Thailand:** PHILIPS ELECTRONICS (THAILAND) Ltd., 209/2 Sanpavuth-Bangna Road Prakanong, BANGKOK 10260, Tel. +66 2 745 4090, Fax. +66 2 398 0793

**Turkey:** Talatpasa Cad. No. 5, 80640 GÜLTEPE/ISTANBUL, Tel. +90 212 279 2770, Fax. +90 212 282 6707

**Ukraine:** PHILIPS UKRAINE, 4 Patrice Lumumba str., Building B, Floor 7, 252042 KIEV, Tel. +380 44 264 2776, Fax. +380 44 268 0461

**United Kingdom:** Philips Semiconductors Ltd., 276 Bath Road, Hayes, MIDDLESEX UB3 5BX, Tel. +44 181 730 5000, Fax. +44 181 754 8421

**United States:** 811 East Arques Avenue, SUNNYVALE, CA 94088-3409, Tel. +1 800 234 7381

**Uruguay:** see South America

**Vietnam:** see Singapore

**Yugoslavia:** PHILIPS, Trg N. Pasica 5/v, 11000 BEOGRAD, Tel. +381 11 625 344, Fax. +381 11 635 777

**For all other countries apply to:** Philips Semiconductors, International Marketing & Sales Communications, Building BE-p, P.O. Box 218, 5600 MD EINDHOVEN, The Netherlands, Fax. +31 40 27 24825

**Internet:** <http://www.semiconductors.philips.com>

© Philips Electronics N.V. 1998

SCA60

All rights are reserved. Reproduction in whole or in part is prohibited without the prior written consent of the copyright owner.

The information presented in this document does not form part of any quotation or contract, is believed to be accurate and reliable and may be changed without notice. No liability will be accepted by the publisher for any consequence of its use. Publication thereof does not convey nor imply any license under patent- or other industrial or intellectual property rights.

Printed in The Netherlands

545102/750/02/pp16

Date of release: 1998 Oct 23

Document order number: 9397 750 04641

*Let's make things better.*

**Philips  
Semiconductors**



**PHILIPS**