

# DATA SHEET

## **TDA8725T** Antenna signal processor

Product specification  
File under Integrated Circuits, IC02

1995 Mar 21

**Philips Semiconductors**



**PHILIPS**

## Antenna signal processor

## TDA8725T

### FEATURES

- 75  $\Omega$  antenna input stage
- 75  $\Omega$  VCR RF input stage
- 75  $\Omega$  VCR tuner output
- 75  $\Omega$  TV tuner output.

### GENERAL DESCRIPTION

The TDA8725T has been designed to split and combine RF signals for Picture-In-Picture (PIP) and VCR applications.

For PIP applications, the antenna input signal is split and fed to the main TV tuner and the PIP tuner. Good signal suppression between the two outputs enables good quality of the main picture when the PIP tuner is in use.

For VCR applications, the antenna input signal is split and then fed directly to the VCR tuner and the TV tuner after being combined with the VCR - RF signal. Good signal suppression between the two outputs enables good quality pictures when the TV and VCR tuners are both operating. Good signal suppression between the VCR input and the antenna input reduces the amount of unwanted signal on the antenna.

### QUICK REFERENCE DATA

SYMBOL	PARAMETER	CONDITIONS	MIN.	TYP.	MAX.	UNIT	
$V_P$	supply voltage (pins 8 and 9)		4.75	5.0	5.25	V	
$I_P$	supply current (pins 8 and 9)		–	65	–	mA	
$f_i$	input frequency		40	–	860	MHz	
$G_p$	power gain						
	from antenna to VCR		3.5	5.0	6.5	dB	
	from antenna to TV		4	5.5	7	dB	
	from VCR		–	0	–	dB	
F	noise figure		6.5	9.0	10	dB	
IP2	antenna linearity 2nd order intercept point	at 40 MHz	137	140	–	dB $\mu$ V	
		at 860 MHz	119	124	–	dB $\mu$ V	
IP3	antenna linearity 3rd order intercept point	at 40 MHz	121	124	–	dB $\mu$ V	
		at 860 MHz	108	111	–	dB $\mu$ V	
$S_{sup}$	signal suppression	VCR input to antenna	0 to 1 GHz	32	37	–	dB
			1 to 3 GHz	25	30	–	dB
	VCR output to TV output	0 to 300 MHz	35	40	–	dB	
		300 to 860 MHz	22	27	–	dB	
	TV output to VCR output	0 to 300 MHz	35	40	–	dB	
		300 to 860 MHz	22	27	–	dB	
VSWR	voltage standing wave ratio	at the antenna input	–	2.5	4		
		at the outputs	–	1.5	3		
$P_{i(max)}$	maximum input power on antenna for 1 dB gain compression		–	–10	–	dBm	

Antenna signal processor

TDA8725T

ORDERING INFORMATION

TYPE NUMBER	PACKAGE		
	NAME	DESCRIPTION	VERSION
TDA8725T	SO16	plastic small outline package; 16 leads; body width 3.9 mm	SOT109-1

BLOCK DIAGRAM

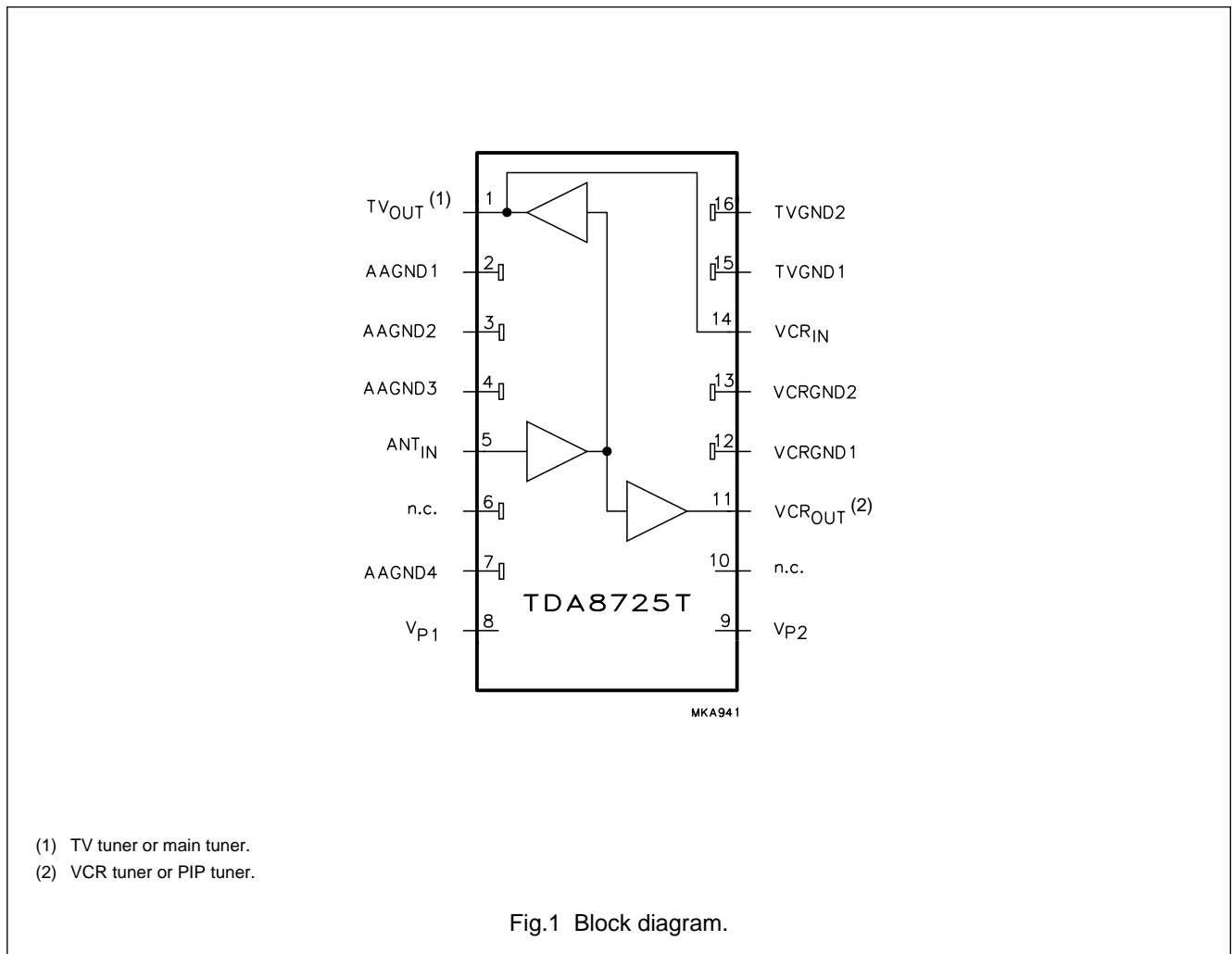

# Antenna signal processor

# TDA8725T

### PINNING

SYMBOL	PIN	DESCRIPTION
TV <sub>OUT</sub>	1	output to TV tuner (VCR+TV) and to main tuner (PIP)
AAGND1	2	antenna amplifier ground 1
AAGND2	3	antenna amplifier ground 2
AAGND3	4	antenna amplifier ground 3
ANT <sub>IN</sub>	5	antenna input
n.c.	6	not connected
AAGND4	7	antenna amplifier ground 4
V <sub>P1</sub>	8	power supply for the antenna amplifier
V <sub>P2</sub>	9	power supply for the VCR output amplifier
n.c.	10	not connected
VCR <sub>OUT</sub>	11	output to VCR and PIP tuner
VCRGND1	12	VCR amplifier ground 1
VCRGND2	13	VCR amplifier ground 2
VCR <sub>IN</sub>	14	VCR RF input
TVGND1	15	TV amplifier ground 1
TVGND2	16	TV amplifier ground 2

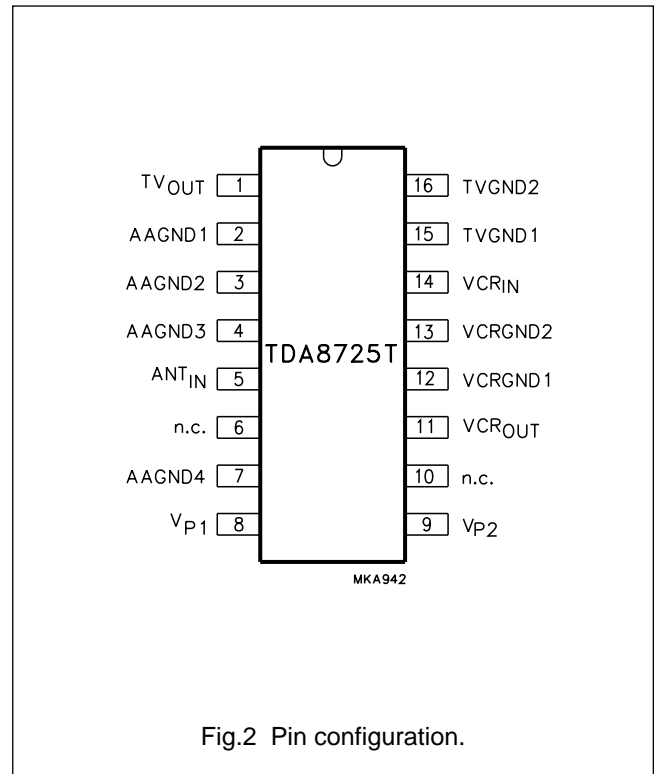

### LIMITING VALUES

In accordance with the Absolute Maximum Rating System (IEC 134).

SYMBOL	PARAMETER	CONDITIONS	MIN.	MAX.	UNIT
V <sub>P</sub>	supply voltage		-0.3	6	V
T <sub>stg</sub>	storage temperature		-55	+150	°C
T <sub>amb</sub>	operating ambient temperature		-10	+80	°C
T <sub>j</sub>	junction temperature		-	+150	°C
V <sub>es</sub>	electrostatic handling	note 1	-2000	+2000	V
		note 2	-200	+200	V

### Notes

- Human Body Model: UZW-BO/FQ-A302 (R = 1500 Ω, C = 100 pF). The IC withstands the ESD test class 2 (2000 V).
- Machine Model: UZW-BO/FQ-B302 (R = 0 Ω, C = 200 pF). All pins withstand 200 V.

### THERMAL CHARACTERISTICS

SYMBOL	PARAMETER	VALUE	UNIT
R <sub>th j-a</sub>	thermal resistance from junction to ambient in free air	115	K/W

## Antenna signal processor

## TDA8725T

**CHARACTERISTICS**

$V_P = 5\text{ V}$ ;  $T_{amb} = 25\text{ °C}$ ; measured in circuit of Fig.4; unless otherwise specified.

SYMBOL	PARAMETER	CONDITIONS	MIN.	TYP.	MAX.	UNIT
$V_P$	supply voltage (pins 8 and 9)		4.75	5.0	5.25	V
$I_P$	supply current (pins 8 and 9)		55	65	75	mA
$f_i$	input frequency		40	–	860	MHz
$G_p$	power gain	40 to 860 MHz				
	from antenna to VCR		3.5	5.0	6.5	dB
	from antenna to TV		4	5.5	7	dB
	from VCR		–	0	–	dB
F	noise figure		6.5	9.0	10	dB
IP2	antenna linearity 2nd order intercept point	at 40 MHz	137	140	–	dB $\mu$ V
		at 860 MHz	119	124	–	dB $\mu$ V
IP3	antenna linearity 3rd order intercept point	at 40 MHz	121	124	–	dB $\mu$ V
		at 860 MHz	108	111	–	dB $\mu$ V
$S_{sup}$	signal suppression VCR input to antenna	0 to 1 GHz	32	37	–	dB
		1 to 3 GHz	25	30	–	dB
	VCR output to TV output	0 to 300 MHz	35	40	–	dB
		300 to 860 MHz	22	27	–	dB
	TV output to VCR output	0 to 300 MHz	35	40	–	dB
		300 to 860 MHz	22	27	–	dB
VSWR	voltage standing wave ratio at the antenna input at the outputs		–	2.5	4	
			–	1.5	3	
$P_{i(max)}$	maximum input power on antenna for 1 dB gain compression		–	–10	–	dBm

Antenna signal processor

TDA8725T

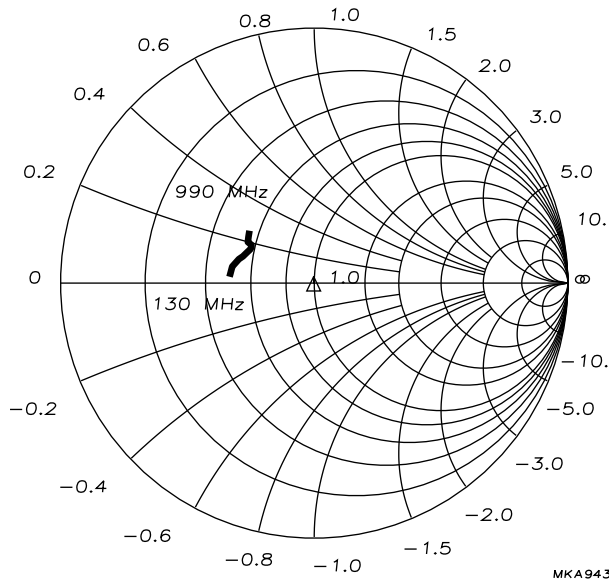

Fig.3 Reflection coefficient (S11) antenna input.

Antenna signal processor

TDA8725T

APPLICATION INFORMATION

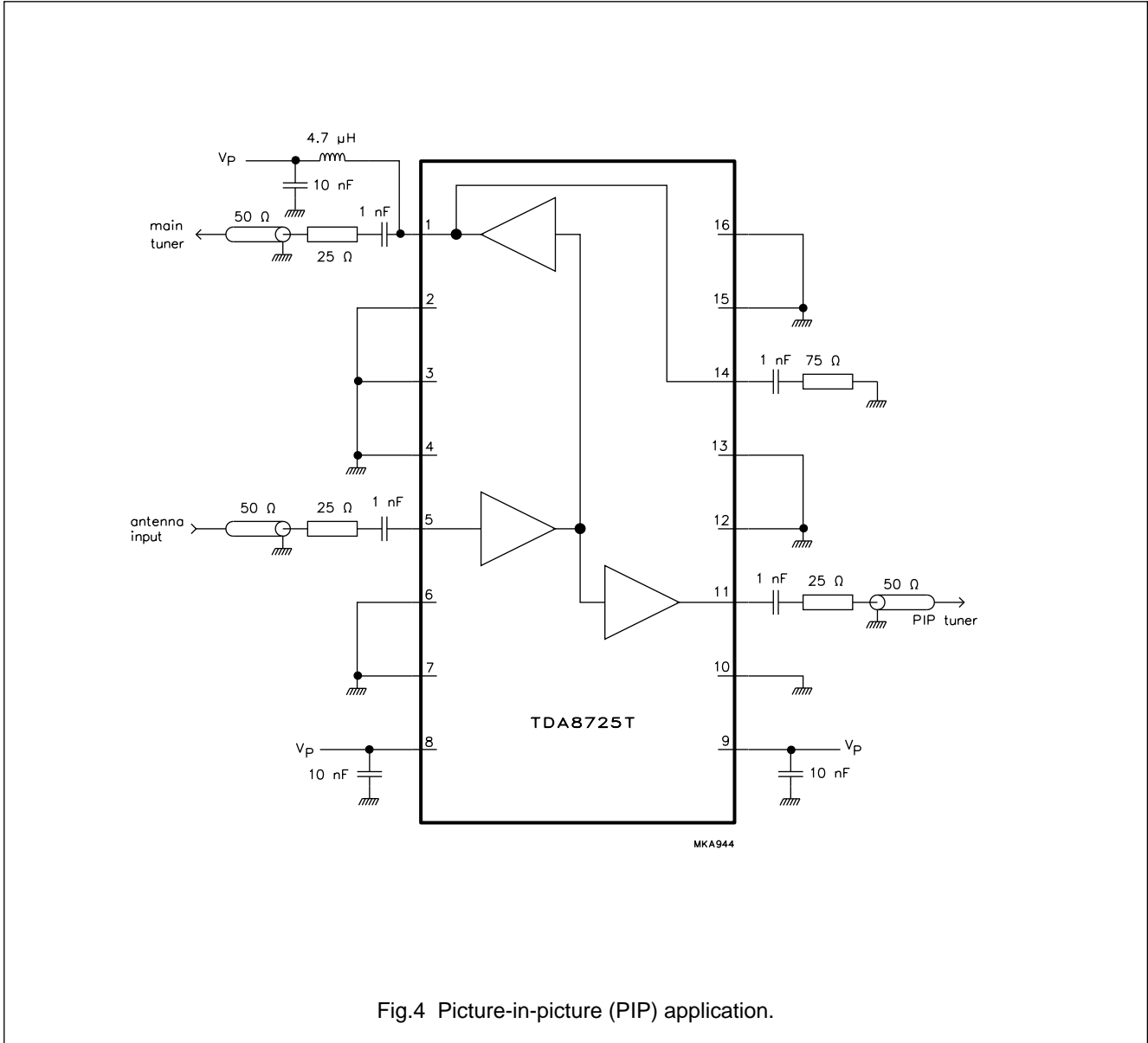

Fig.4 Picture-in-picture (PIP) application.

Antenna signal processor

TDA8725T

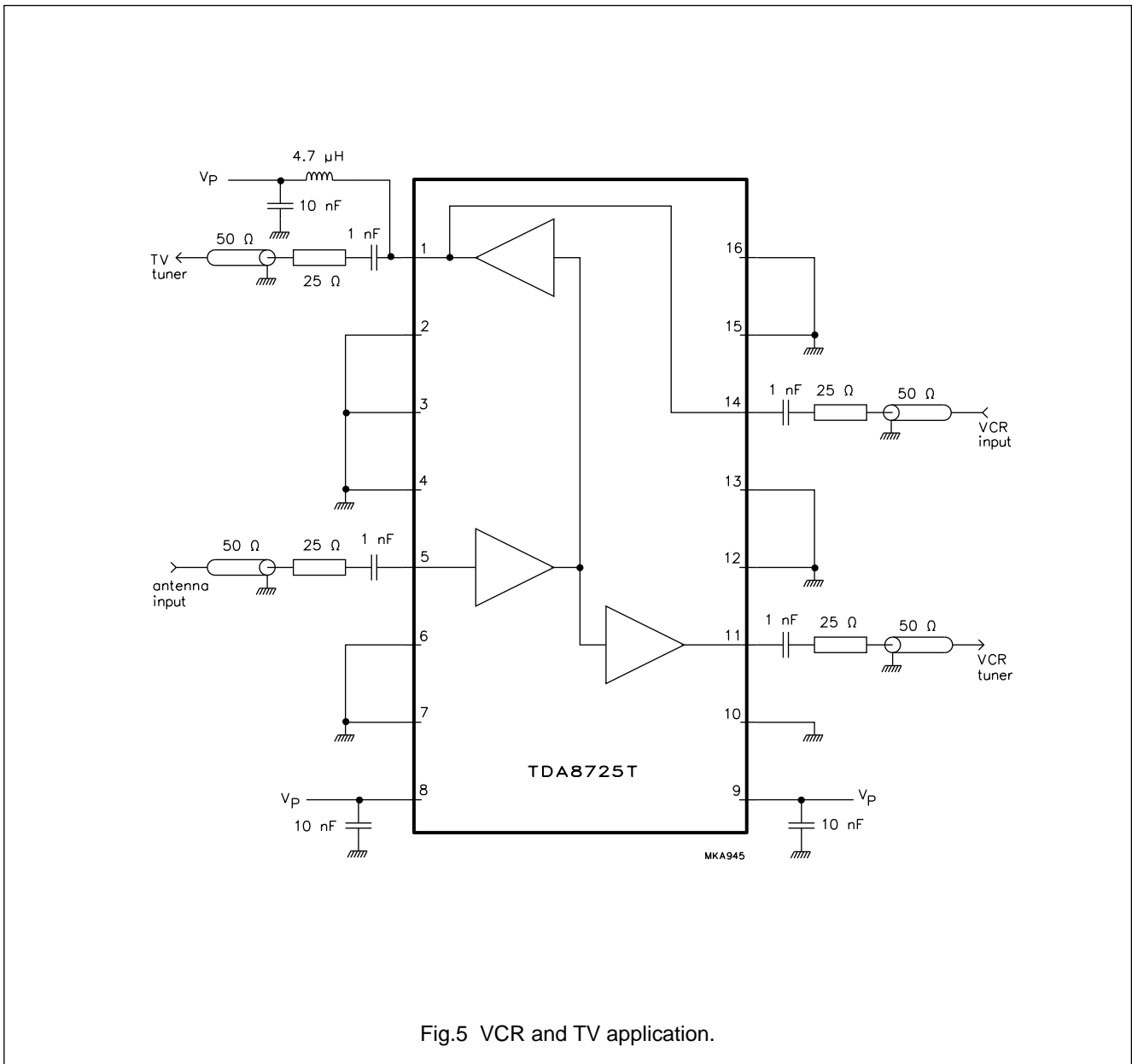

Fig.5 VCR and TV application.



Antenna signal processor

TDA8725T

PACKAGE OUTLINE

SO16: plastic small outline package; 16 leads; body width 3.9 mm

SOT109-1

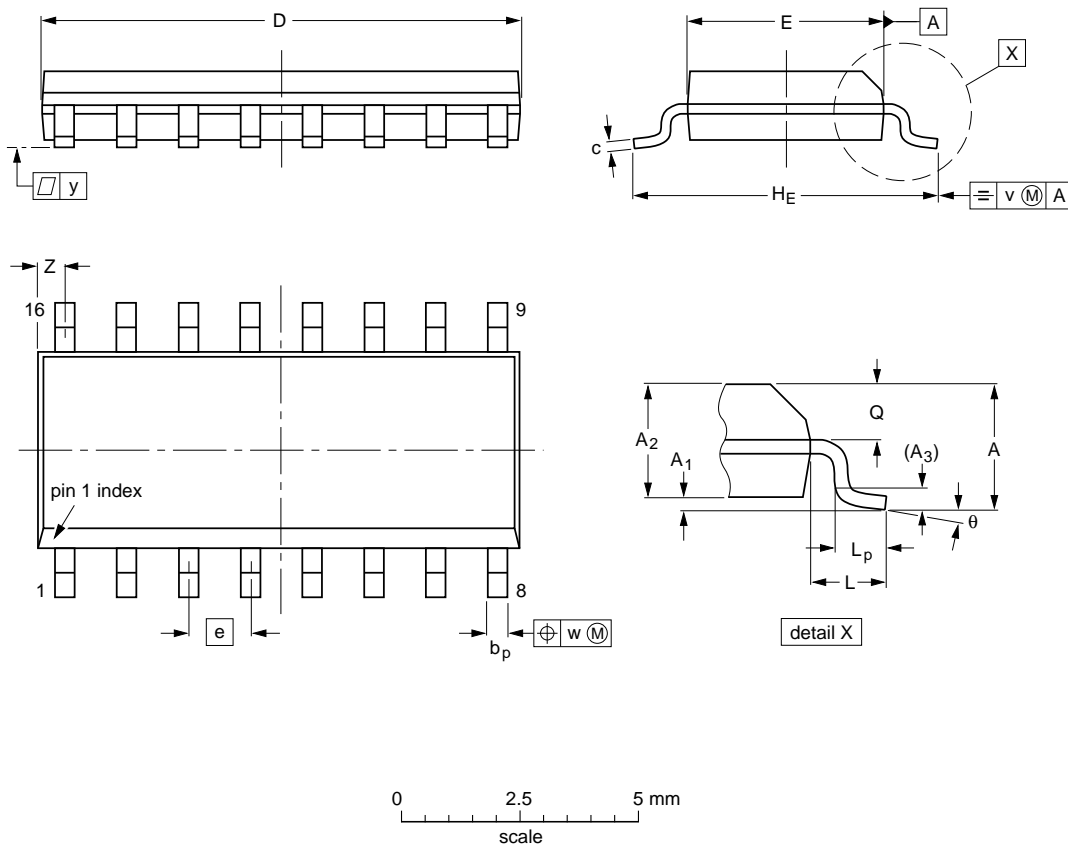

DIMENSIONS (inch dimensions are derived from the original mm dimensions)

UNIT	A max.	A <sub>1</sub>	A <sub>2</sub>	A <sub>3</sub>	b <sub>p</sub>	c	D <sup>(1)</sup>	E <sup>(1)</sup>	e	H <sub>E</sub>	L	L <sub>p</sub>	Q	v	w	y	Z <sup>(1)</sup>	$\theta$
mm	1.75	0.25 0.10	1.45 1.25	0.25	0.49 0.36	0.25 0.19	10.0 9.8	4.0 3.8	1.27	6.2 5.8	1.05	1.0 0.4	0.7 0.6	0.25	0.25	0.1	0.7 0.3	8° 0°
inches	0.069	0.0098 0.0039	0.057 0.049	0.01	0.019 0.014	0.0098 0.0075	0.39 0.38	0.16 0.15	0.050	0.24 0.23	0.041	0.039 0.016	0.028 0.020	0.01	0.01	0.004	0.028 0.012	

Note

1. Plastic or metal protrusions of 0.15 mm maximum per side are not included.

OUTLINE VERSION	REFERENCES				EUROPEAN PROJECTION	ISSUE DATE
	IEC	JEDEC	EIAJ			
SOT109-1	076E07S	MS-012AC				94-08-13 95-01-23

## Antenna signal processor

## TDA8725T

### SOLDERING

#### Plastic small-outline packages

##### BY WAVE

During placement and before soldering, the component must be fixed with a droplet of adhesive. After curing the adhesive, the component can be soldered. The adhesive can be applied by screen printing, pin transfer or syringe dispensing.

Maximum permissible solder temperature is 260 °C, and maximum duration of package immersion in solder bath is 10 s, if allowed to cool to less than 150 °C within 6 s. Typical dwell time is 4 s at 250 °C.

A modified wave soldering technique is recommended using two solder waves (dual-wave), in which a turbulent wave with high upward pressure is followed by a smooth laminar wave. Using a mildly-activated flux eliminates the need for removal of corrosive residues in most applications.

##### BY SOLDER PASTE REFLOW

Reflow soldering requires the solder paste (a suspension of fine solder particles, flux and binding agent) to be applied to the substrate by screen printing, stencilling or pressure-syringe dispensing before device placement.

Several techniques exist for reflowing; for example, thermal conduction by heated belt, infrared, and vapour-phase reflow. Dwell times vary between 50 and 300 s according to method. Typical reflow temperatures range from 215 to 250 °C.

Preheating is necessary to dry the paste and evaporate the binding agent. Preheating duration: 45 min at 45 °C.

##### REPAIRING SOLDERED JOINTS (BY HAND-HELD SOLDERING IRON OR PULSE-HEATED SOLDER TOOL)

Fix the component by first soldering two, diagonally opposite, end pins. Apply the heating tool to the flat part of the pin only. Contact time must be limited to 10 s at up to 300 °C. When using proper tools, all other pins can be soldered in one operation within 2 to 5 s at between 270 and 320 °C. (Pulse-heated soldering is not recommended for SO packages.)

For pulse-heated solder tool (resistance) soldering of VSO packages, solder is applied to the substrate by dipping or by an extra thick tin/lead plating before package placement.

### DEFINITIONS

<b>Data sheet status</b>	
Objective specification	This data sheet contains target or goal specifications for product development.
Preliminary specification	This data sheet contains preliminary data; supplementary data may be published later.
Product specification	This data sheet contains final product specifications.
<b>Limiting values</b>	
Limiting values given are in accordance with the Absolute Maximum Rating System (IEC 134). Stress above one or more of the limiting values may cause permanent damage to the device. These are stress ratings only and operation of the device at these or at any other conditions above those given in the Characteristics sections of the specification is not implied. Exposure to limiting values for extended periods may affect device reliability.	
<b>Application information</b>	
Where application information is given, it is advisory and does not form part of the specification.	

### LIFE SUPPORT APPLICATIONS

These products are not designed for use in life support appliances, devices, or systems where malfunction of these products can reasonably be expected to result in personal injury. Philips customers using or selling these products for use in such applications do so at their own risk and agree to fully indemnify Philips for any damages resulting from such improper use or sale.