

# DATA SHEET

## **TDA8787A**

10-bit, 3.0 V, up to 18 Msps  
analog-to-digital interface for  
CCD cameras

Product specification  
Supersedes data of 2000 Nov 14

2002 Oct 25

# 10-bit, 3.0 V, up to 18 Msps analog-to-digital interface for CCD cameras

## TDA8787A

### FEATURES

- Correlated Double Sampling (CDS), Programmable Gain Amplifier (PGA), 10-bit Analog-to-Digital Converter (ADC) and reference regulator included
- Fully programmable via a 3-wire serial interface
- Sampling frequency up to 18 MHz
- PGA gain range of 36 dB (in steps of 0.1 dB)
- Low power consumption of only 170 mW at 2.7 V
- Power consumption in standby mode of 4.5 mW (typical value)
- 3.0 V operation; 2.5 to 3.6 V operation for the digital outputs
- Active control pulses polarity selectable via serial interface
- 8-bit DAC included for analog settings
- TTL compatible inputs, CMOS compatible outputs.

### APPLICATIONS

- Low-power, low-voltage CCD camera systems.

### GENERAL DESCRIPTION

The TDA8787A is a 10-bit analog-to-digital interface for CCD cameras. The device includes a correlated double sampling circuit, a PGA, clamp loops and a low-power 10-bit ADC, together with its reference voltage regulator.

The PGA gain and the ADC input clamp level are controlled via the serial interface.

An additional DAC is provided for additional system controls. Its output voltage range is 1.0 V peak-to-peak which is available at pin OFDOUT.

### ORDERING INFORMATION

TYPE NUMBER	PACKAGE		
	NAME	DESCRIPTION	VERSION
TDA8787AHL	LQFP48	plastic low profile quad flat package; 48 leads; body 7 × 7 × 1.4 mm	SOT313-2

# 10-bit, 3.0 V, up to 18 Msps analog-to-digital interface for CCD cameras

TDA8787A

## QUICK REFERENCE DATA

SYMBOL	PARAMETER	CONDITIONS	MIN.	TYP.	MAX.	UNIT
$V_{CCA}$	analog supply voltage		2.7	3.0	3.6	V
$V_{CCD}$	digital supply voltage		2.7	3.0	3.6	V
$V_{CCO}$	digital outputs stages supply voltage		2.5	2.6	3.6	V
$I_{CCA}$	analog supply current	all clamps active; $f_{pix} = 18$ MHz	–	50	60	mA
$I_{CCD}$	digital supply current	$f_{pix} = 18$ MHz	–	13	17	mA
$I_{CCO}$	digital outputs supply current	$f_{pix} = 18$ MHz; $C_L = 20$ pF; input ramp response time is 800 $\mu$ s	–	1	2	mA
$ADC_{res}$	ADC resolution		–	10	–	bits
$V_{i(CDS)(p-p)}$	CDS input amplitude (video signal) (peak-to-peak value)	$V_{CC} = 2.85$ V	650	–	–	mV
		$V_{CC} \geq 3.0$ V	800	–	–	mV
$f_{pix(max)}$	maximum pixel frequency		18	–	–	MHz
$f_{pix(min)}$	minimum pixel frequency		2	–	–	MHz
$DR_{PGA}$	PGA dynamic range		–	36	–	dB
$N_{tot(rms)}$	total noise (RMS value) at CDS input to ADC output	PGA code = 0; see Fig.8	–	0.15	–	LSB
$V_{n(i)(eq)(rms)}$	equivalent input noise voltage (RMS value)	PGA code = 383	–	70	–	$\mu$ V
$P_{tot}$	total power consumption	$V_{CCA} = V_{CCD} = V_{CCO} = 3$ V	–	190	–	mW
		$V_{CCA} = V_{CCD} = V_{CCO} = 2.7$ V	–	170	–	mW

10-bit, 3.0 V, up to 18 Msps analog-to-digital interface for CCD cameras

TDA8787A

BLOCK DIAGRAM

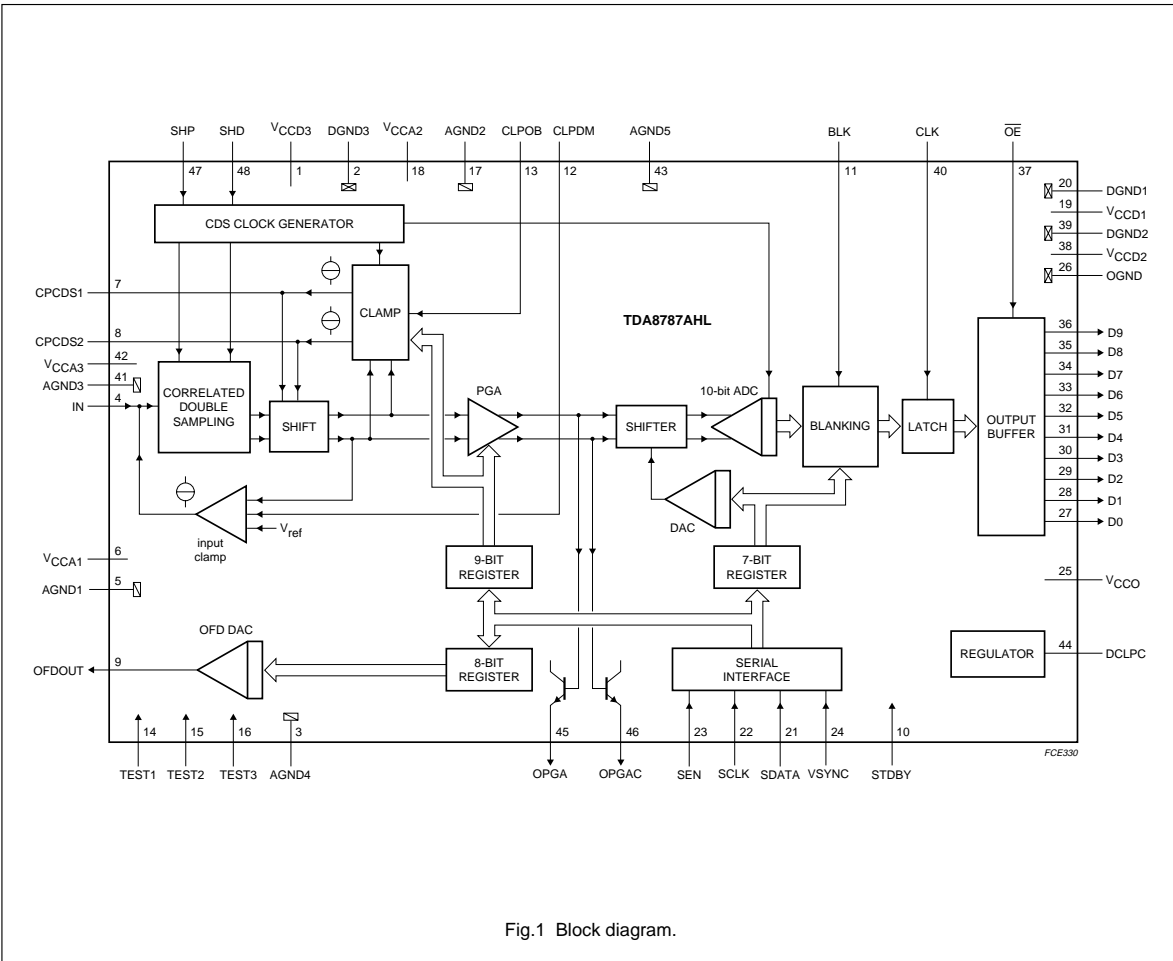

Fig.1 Block diagram.

# 10-bit, 3.0 V, up to 18 Msps analog-to-digital interface for CCD cameras

TDA8787A

## PINNING

SYMBOL	PIN	DESCRIPTION
V <sub>CCD3</sub>	1	digital supply voltage 3
DGND3	2	digital ground 3
AGND4	3	analog ground 4
IN	4	input signal from CCD
AGND1	5	analog ground 1
V <sub>CCA1</sub>	6	analog supply voltage 1
CPCDS1	7	clamp storage capacitor 1
CPCDS2	8	clamp storage capacitor 2
OFDOUT	9	analog output of the additional 8-bit control DAC
STDBY	10	standby mode control input (LOW: TDA8787A active; HIGH: TDA8787A standby)
BLK	11	blanking control input
CLPDM	12	clamp pulse input at dummy pixel (should be connected to ground)
CLPOB	13	clamp pulse input for optical black
TEST1	14	test pin input 1 (should be connected to AGND2)
TEST2	15	test pin input 2 (should be connected to AGND2)
TEST3	16	test pin input 3 (should be connected to AGND2)
AGND2	17	analog ground 2
V <sub>CCA2</sub>	18	analog supply voltage 2
V <sub>CCD1</sub>	19	digital supply voltage 1
DGND1	20	digital ground 1
SDATA	21	serial data input for serial interface control
SCLK	22	serial clock input for serial interface control
SEN	23	strobe pin for serial interface control
VSYNC	24	vertical sync pulse input
V <sub>CCO</sub>	25	output stages supply voltage
OGND	26	digital output ground
D0	27	ADC digital output 0 (LSB)
D1	28	ADC digital output 1
D2	29	ADC digital output 2
D3	30	ADC digital output 3
D4	31	ADC digital output 4
D5	32	ADC digital output 5
D6	33	ADC digital output 6
D7	34	ADC digital output 7
D8	35	ADC digital output 8
D9	36	ADC digital output 9 (MSB)
$\overline{OE}$	37	output enable control input (LOW: outputs active; HIGH: outputs in high impedance)
V <sub>CCD2</sub>	38	digital supply 2
DGND2	39	digital ground 2
CLK	40	data clock input

10-bit, 3.0 V, up to 18 Msps analog-to-digital interface for CCD cameras

TDA8787A

SYMBOL	PIN	DESCRIPTION
AGND3	41	analog ground 3
V <sub>CCA3</sub>	42	analog supply 3
AGND5	43	analog ground 5
DCLPC	44	regulator decoupling pin
OPGA	45	PGA output (test pin)
OPGAC	46	PGA complementary output (test pin)
SHP	47	preset sample-and-hold pulse input
SHD	48	data sample-and-hold pulse input

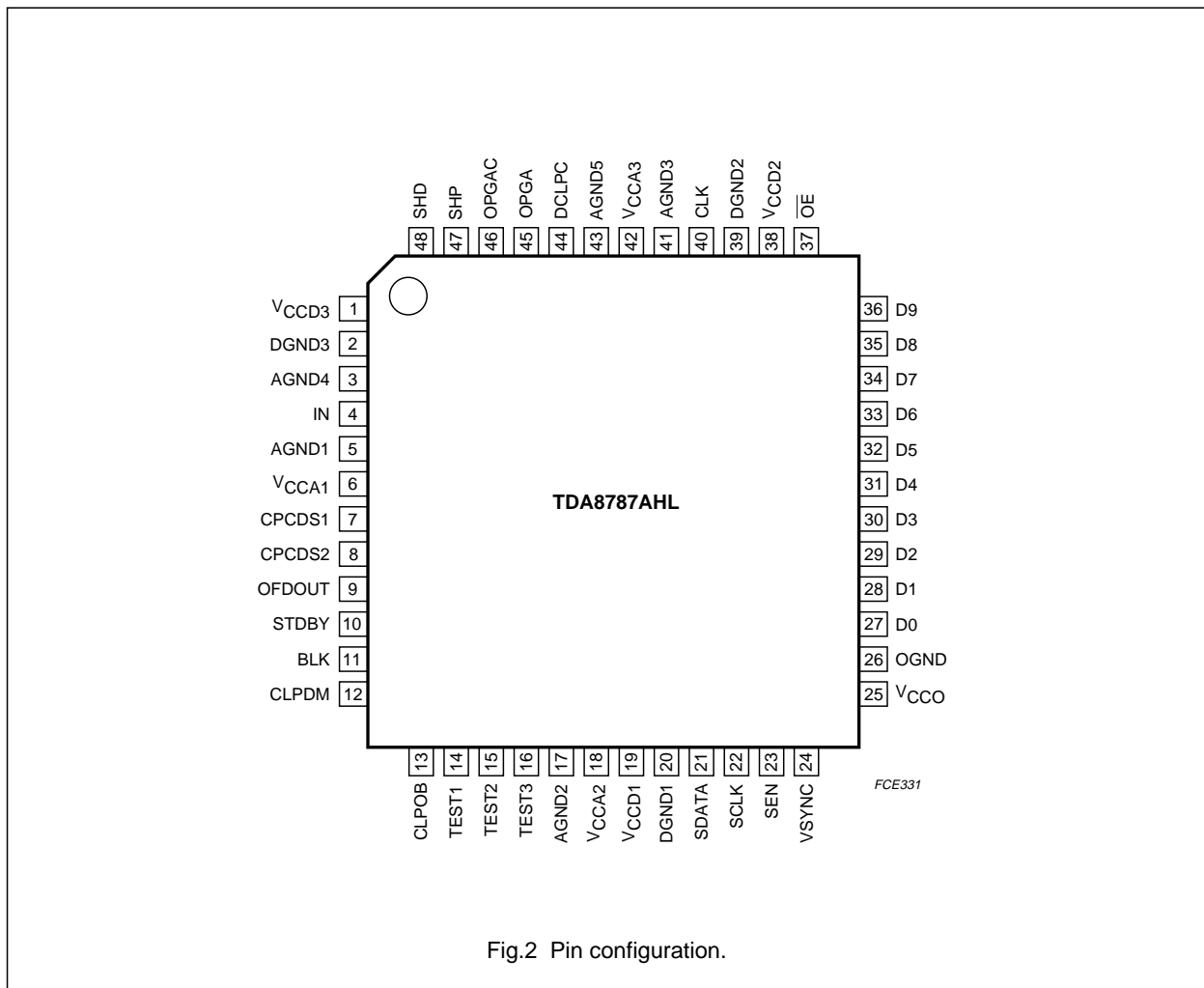

Fig.2 Pin configuration.

# 10-bit, 3.0 V, up to 18 Msps analog-to-digital interface for CCD cameras

TDA8787A

## LIMITING VALUES

In accordance with the Absolute Maximum Rating System (IEC 60134).

SYMBOL	PARAMETER	CONDITIONS	MIN.	MAX.	UNIT
$V_{CCA}$	analog supply voltage	note 1	-0.3	+5.0	V
$V_{CCD}$	digital supply voltage	note 1	-0.3	+5.0	V
$V_{CCO}$	output stages supply voltage	note 1	-0.3	+5.0	V
$\Delta V_{CC}$	supply voltage difference between $V_{CCA}$ and $V_{CCD}$ between $V_{CCA}$ and $V_{CCO}$ between $V_{CCD}$ and $V_{CCO}$		-0.5 -0.5 -0.5	+0.5 +1.2 +1.2	V V V
$V_i$	input voltage	referenced to AGND	-0.3	+5.0	V
$I_o$	data output current		-	$\pm 10$	mA
$T_{stg}$	storage temperature		-55	+150	°C
$T_{amb}$	ambient temperature		-20	+75	°C
$T_j$	junction temperature		-	150	°C

### Note

- The supply voltages  $V_{CCA}$ ,  $V_{CCD}$  and  $V_{CCO}$  may have any value between -0.3 and +5.0 V provided that the supply voltage difference  $\Delta V_{CC}$  remains as indicated.

## HANDLING

Inputs and outputs are protected against electrostatic discharges in normal handling. However, to be totally safe, it is desirable to take normal precautions appropriate to handling integrated circuits.

## THERMAL CHARACTERISTICS

SYMBOL	PARAMETER	CONDITIONS	VALUE	UNIT
$R_{th(j-a)}$	thermal resistance from junction to ambient	in free air	76	K/W

# 10-bit, 3.0 V, up to 18 Msps analog-to-digital interface for CCD cameras

TDA8787A

## CHARACTERISTICS

$V_{CCA} = V_{CCD} = 3.0\text{ V}$ ;  $V_{CCO} = 2.6\text{ V}$ ;  $f_{\text{pix}} = 18\text{ MHz}$ ;  $T_{\text{amb}} = -20\text{ to }+75^\circ\text{C}$ ; unless otherwise specified.

SYMBOL	PARAMETER	CONDITIONS	MIN.	TYP.	MAX.	UNIT
<b>Supplies</b>						
$V_{CCA}$	analog supply voltage		2.7	3.0	3.6	V
$V_{CCD}$	digital supply voltage		2.7	3.0	3.6	V
$V_{CCO}$	digital outputs stages supply voltage		2.5	2.6	3.6	V
$I_{CCA}$	analog supply current	all clamps active	–	50	60	mA
$I_{CCD}$	digital supply current		–	13	17	mA
$I_{CCO}$	digital outputs supply current	$C_L = 20\text{ pF}$ on all data outputs; input ramp response time is $800\text{ }\mu\text{s}$	–	1	2	mA
$P_{\text{tot}}$	total power consumption	$V_{CCA} = V_{CCD} = V_{CCO} = 3\text{ V}$	–	190	–	mW
		$V_{CCA} = V_{CCD} = V_{CCO} = 2.7\text{ V}$	–	170	–	mW
<b>Digital inputs</b>						
INPUTS: PINS STDBY, CLPDM, CLPOB, SCLK, SDATA, SEN, VSYNC, $\overline{\text{OE}}$ , CLK AND BLK						
$V_{\text{IL}}$	LOW-level input voltage		0	–	0.6	V
$V_{\text{IH}}$	HIGH-level input voltage		2.2	–	5.0	V
$I_i$	input current	$0 \leq V_i \leq V_{\text{CCD}}$	–2	–	+2	$\mu\text{A}$
INPUTS: PINS SHP AND SHD						
$V_{\text{IL}}$	LOW-level input voltage		0	–	0.6	V
$V_{\text{IH}}$	HIGH-level input voltage		2.2	–	5.0	V
$I_i$	input current	$0 \leq V_i \leq V_{\text{CCD}}$	–10	–	+10	$\mu\text{A}$
<b>Clamps</b>						
GLOBAL CHARACTERISTICS OF THE CLAMP LOOPS						
$t_{\text{W}(\text{clamp})}$	clamp active pulse width in numbers of pixels	PGA input code = 255 for maximum 4 LSB error	12	–	–	pixels
INPUT CLAMP: PIN CLPDM						
$g_{\text{m}(\text{CDS})}$	CDS input clamp transconductance		1.5	2.7	3.5	mS
OPTICAL BLACK CLAMP: PIN CLPOB						
$G_{\text{shift}}$	gain from CPCDS1 and 2 to PGA inputs		–	0.27	–	
$I_{\text{LSB}(\text{cp})}$	charge pump current for $\pm 1\text{ LSB}$ error at ADC output	PGA input code = 0	–	$\pm 20$	–	$\mu\text{A}$
		PGA input code = 383	–	$\pm 0.60$	–	$\mu\text{A}$



# 10-bit, 3.0 V, up to 18 Msps analog-to-digital interface for CCD cameras

TDA8787A

SYMBOL	PARAMETER	CONDITIONS	MIN.	TYP.	MAX.	UNIT
<b>Correlated Double Sampling (CDS): pin IN</b>						
$V_{i(\text{CDS})(\text{p-p})}$	CDS input amplitude (video signal) (peak-to-peak value)	$V_{\text{CC}} = 2.85 \text{ V}$	650	–	–	mV
		$V_{\text{CC}} \geq 3.0 \text{ V}$	800	–	–	mV
$V_{i(\text{rst})(\text{max})}$	maximum CDS input reset pulse amplitude		500	–	–	mV
$I_i$	input current	at floating gate level	–1	–	+1	$\mu\text{A}$
$C_i$	input capacitance		–	2	–	pF
$t_{\text{CDS}(\text{min})}$	CDS control pulses minimum active time	$V_{i(\text{CDS})(\text{p-p})} = 800 \text{ mV}$ ; black-to-white transition in 1 pixel ( $\pm 2 \text{ LSB}$ typical); $T_{\text{amb}} = 25 \text{ }^\circ\text{C}$ ; note 1	11	15	–	ns
$t_{\text{h}(\text{IN-SHP})}$	hold time SHP to IN	$T_{\text{amb}} = 25 \text{ }^\circ\text{C}$ ; see Figs 3 and 4	–	1	2	ns
$t_{\text{h}(\text{IN-SHD})}$	hold time SHD to IN	$T_{\text{amb}} = 25 \text{ }^\circ\text{C}$ ; see Figs 3 and 4	–	1	2	ns
<b>Amplifier</b>						
$\text{DR}_{\text{PGA}}$	PGA dynamic range		–	36	–	dB
$\Delta\text{G}_{\text{PGA}}$	PGA gain step		–0.3	–	+0.3	dB
<b>Analog-to-Digital Converter (ADC)</b>						
$\text{LE}_{(\text{i})}$	integral non-linearity error	$f_{\text{pix}} = 18 \text{ MHz}$ ; ramp input	–	$\pm 1.3$	$\pm 2.5$	LSB
$\text{LE}_{(\text{d})}$	differential non-linearity error	$f_{\text{pix}} = 18 \text{ MHz}$ ; ramp input	–	$\pm 0.5$	$\pm 0.9$	LSB
<b>Total chain characteristics (CDS, PGA and ADC)</b>						
$f_{\text{pix}(\text{max})}$	maximum pixel frequency		18	–	–	MHz
$f_{\text{pix}(\text{min})}$	minimum pixel frequency		2	–	–	MHz
$t_{\text{CLKH}}$	clock HIGH time		15	–	–	ns
$t_{\text{CLKL}}$	clock LOW time		15	–	–	ns
$t_{\text{d}(\text{SHD-CLK})}$	time delay SHD to CLK	see Fig.3	10	–	–	ns
$t_{\text{su}(\text{BLK-CLK})}$	set-up time of BLK compared to CLK		10	–	–	ns
$V_{i(\text{IN})}$	video input dynamic signal for ADC full-scale output	PGA input code = 0	800	–	–	mV
		PGA input code = 383	12.7	–	–	mV
$N_{\text{tot}(\text{rms})}$	total noise from CDS input to ADC output (RMS value)	see Fig.8 PGA input code = 0	–	0.15	–	LSB
		PGA input code = 96	–	0.8	–	LSB
$V_{n(\text{i})(\text{eq})(\text{rms})}$	equivalent input noise voltage (RMS value)	PGA input code = 383	–	70	–	$\mu\text{V}$
		PGA input code = 0	–	120	–	$\mu\text{V}$
$O_{\text{CCD}(\text{max})}$	maximum offset between CCD floating level and CCD dark pixel level		–80	–	+80	mV

# 10-bit, 3.0 V, up to 18 Msps analog-to-digital interface for CCD cameras

TDA8787A

SYMBOL	PARAMETER	CONDITIONS	MIN.	TYP.	MAX.	UNIT
<b>Digital-to-Analog Converter (OFDOUT DAC)</b>						
$V_{\text{OFDOUT(p-p)}}$	additional 8-bit control DAC (OFD) output voltage (peak-to-peak value)	$R_L = 1 \text{ M}\Omega$	–	1.0	–	V
$V_{\text{OFDOUT}}$	DC output voltage	OFD input code 0	–	AGND	–	V
		OFD input code 255	–	AGND + 1.0	–	V
$TC_{\text{OFD}}$	OFD output range temperature coefficient		–	250	–	ppm/K
$Z_{\text{OFDOUT}}$	OFD output impedance		–	2000	–	$\Omega$
$I_{\text{OFDOUT}}$	OFD output drive current	static	–	–	100	$\mu\text{A}$
<b>Digital outputs (<math>f_{\text{pix}} = 18 \text{ MHz}</math>; <math>C_L = 10 \text{ pF}</math>); see Figs 3 and 4</b>						
$V_{\text{OH}}$	HIGH-level output voltage	$I_{\text{OH}} = -1 \text{ mA}$	$V_{\text{CCO}} - 0.5$	–	$V_{\text{CCO}}$	V
$V_{\text{OL}}$	LOW-level output voltage	$I_{\text{OL}} = 1 \text{ mA}$	0	–	0.5	V
$I_{\text{OZ}}$	OFF-state output current	$0.5 \text{ V} < V_{\text{OZ}} < V_{\text{CCO}}$	–20	–	+20	$\mu\text{A}$
$t_{\text{h(o)}}$	output hold time		9	–	–	ns
$t_{\text{d(o)}}$	output delay time	$V_{\text{CCO}} = 3.0 \text{ V}$	–	17	23	ns
		$V_{\text{CCO}} = 2.7 \text{ V}$	–	19	25	ns
$C_L$	load capacitance		–	–	22	$\mu\text{F}$
<b>Serial interface</b>						
$f_{\text{SCLK(max)}}$	maximum frequency pin SCLK		5	–	–	MHz

**Note**

- Depending on application environments and especially in case of high gain operation and digital supply with jitter, it is preferable to apply 12 ns or higher CDS pulses.

10-bit, 3.0 V, up to 18 Msps analog-to-digital interface for CCD cameras

TDA8787A

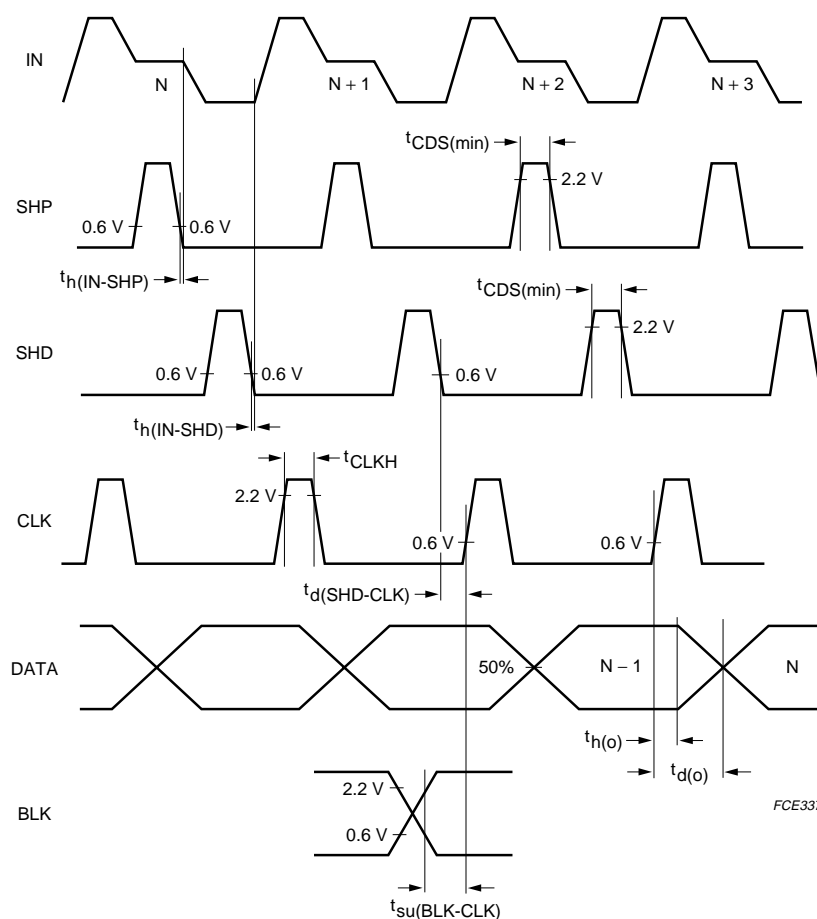

Fig.3 Pixel frequency timing diagram with active HIGH-level polarities.

10-bit, 3.0 V, up to 18 Msps analog-to-digital interface for CCD cameras

TDA8787A

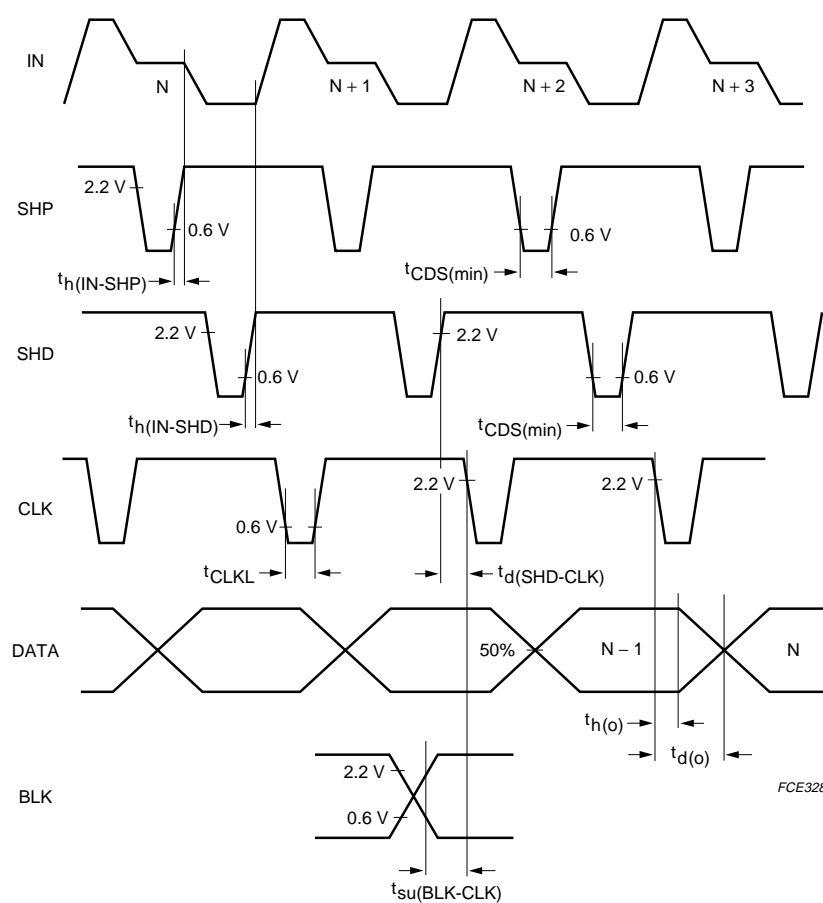

Fig.4 Pixel frequency timing diagram with active LOW-level polarities.

10-bit, 3.0 V, up to 18 Msps analog-to-digital interface for CCD cameras

TDA8787A

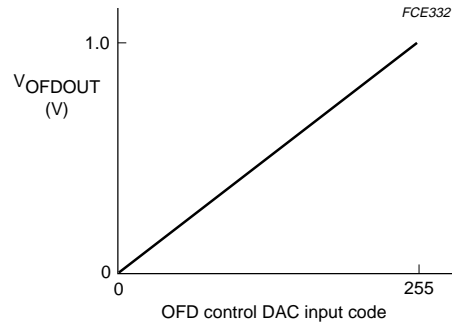
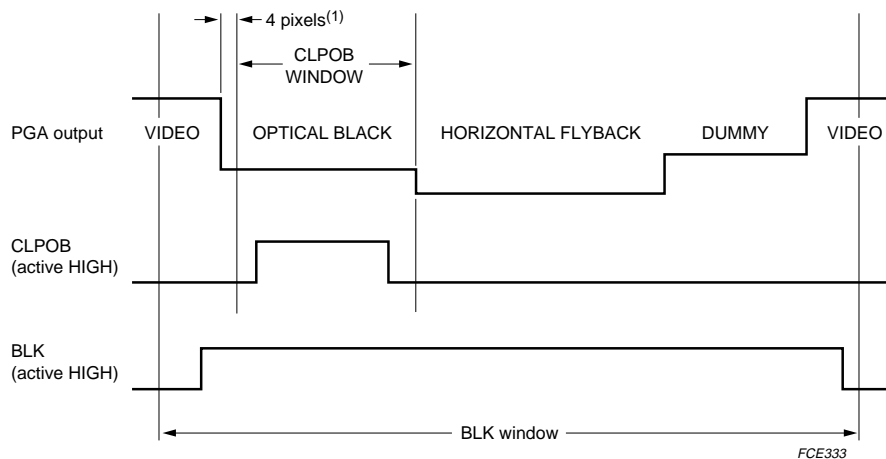

Fig.5 DAC output voltage output as a function of DAC input code.



(1) In this case the number of clamp pixels is limited to  $18 \times (t_{W(\text{clamp})})$ ; otherwise this timing interval can be

Fig.6 Line frequency timing diagram.

# 10-bit, 3.0 V, up to 18 Msps analog-to-digital interface for CCD cameras

TDA8787A

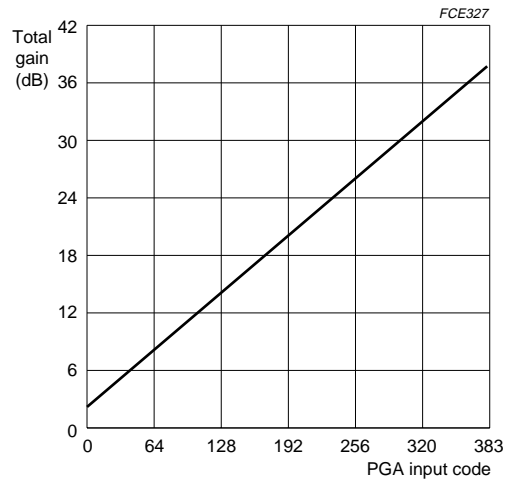

ADC input range is 1 V<sub>pp</sub>.

Fig.7 Total gain as a function of PGA input code.

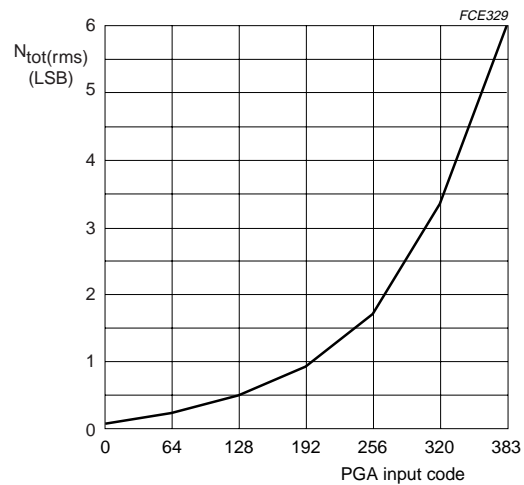

Noise measurement at ADC outputs; coupling capacitor at input is grounded, so only noise contribution of the front-end is evaluated. Front-end works at 18 Mpixels with line of 1024 pixels whose first 40 are used to run CLPOB and the last 40 for CLPDM. Data at the ADC outputs are measured during the other pixels. As a result of this, the standard deviation of the codes statistic is computed, resulting in the noise.

Fig.8 Typical total noise performance as a function of PGA gain.

10-bit, 3.0 V, up to 18 Msp/s analog-to-digital interface for CCD cameras

TDA8787A

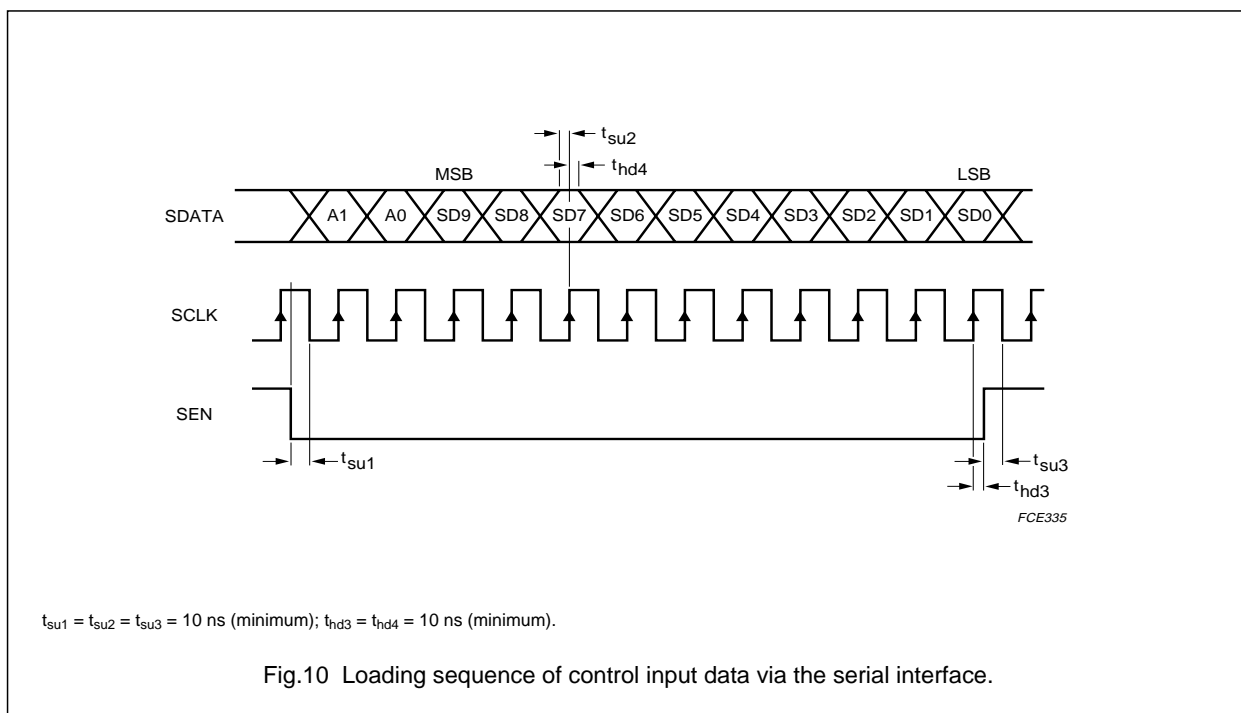
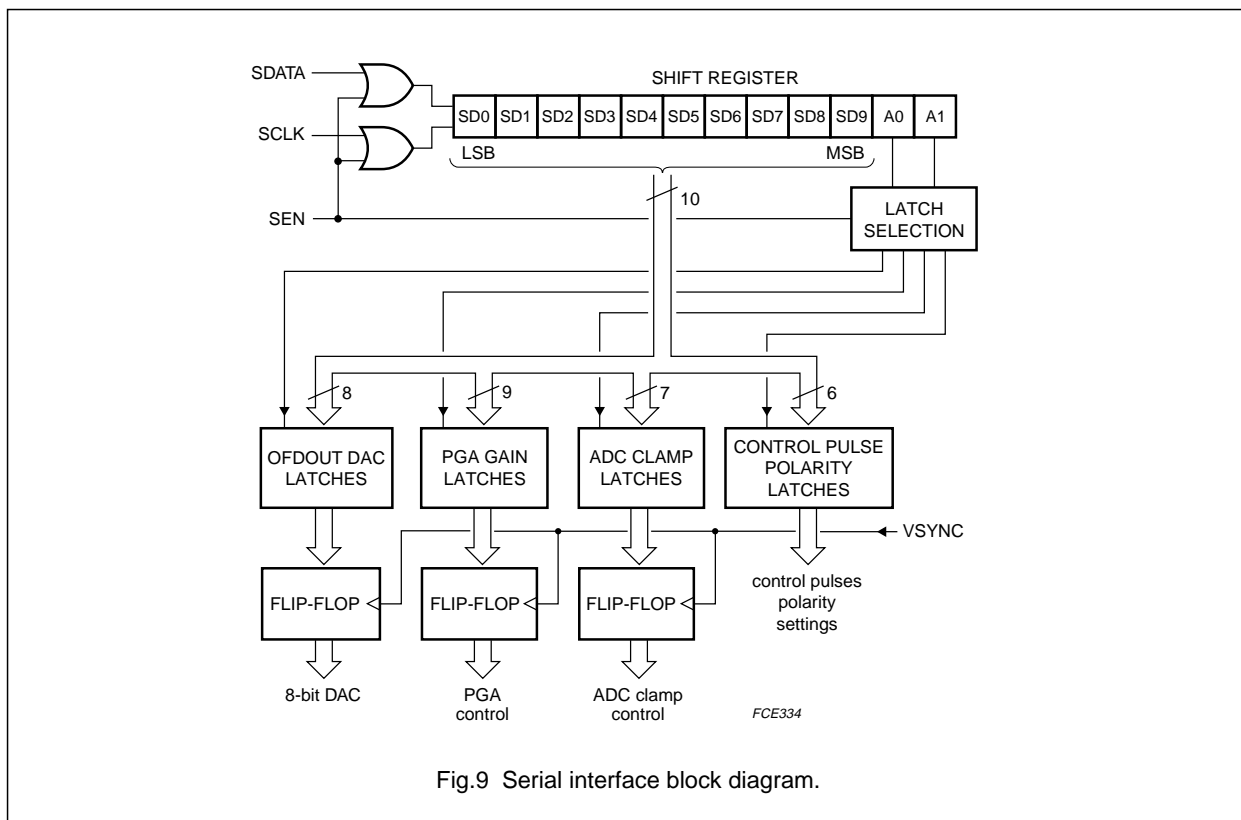

# 10-bit, 3.0 V, up to 18 Msps analog-to-digital interface for CCD cameras

TDA8787A

**Table 1** Serial interface programming; see Figs 9 and 10

ADDRESS BITS		DATA BITS SD9 TO SD0
A1	A0	
0	0	PGA gain control (bits SD8 to SD0); bit SD9 should be set to logic 0
0	1	DAC OFDOUT output control (bits SD7 to SD0); bits SD8 and SD9 should be set to logic 0
1	0	ADC clamp reference control (SD6 to SD0); from code 0 to 127; bits SD7, SD8 and SD9 should be set to logic 0
1	1	control pulses polarity settings (pins SHP, SHD, CLPDM, CLPOB, BLK and CLK)

**Table 2** Polarity settings

SYMBOL	PIN	SERIAL CONTROL BIT <sup>(1)</sup>	ACTIVE EDGE OR LEVEL
SHP and SHD	47 and 48	SD0	1 = HIGH; 0 = LOW
CLK	40	SD1	1 = HIGH; 0 = LOW
CLPDM	12 (connected to ground)	SD2	always 0 = LOW
CLPOB	13	SD3	1 = HIGH; 0 = LOW
BLK	11	SD5	1 = HIGH; 0 = LOW
VSYNC	24	SD6	0 = rising; 1 = falling

**Note**

- Bit SD4 is not used.

**Table 3** Standby mode selection; pin STDBY

STDBY	ADC DIGITAL OUTPUTS; PINS D9 TO D0	I <sub>CCA</sub> + I <sub>CCO</sub> + I <sub>CCD</sub> (typical)
1	logic state LOW	1.5 mA
0	active	64 mA

**Table 4** Output enable ( $\overline{OE}$ ) pin 37

$\overline{OE}$	ADC DIGITAL OUTPUTS; PINS D9 TO D0
0	active, binary
1	high impedance



---

## 10-bit, 3.0 V, up to 18 Msps analog-to-digital interface for CCD cameras

---

TDA8787A

### APPLICATION INFORMATION

#### Power and grounding recommendations

When designing a printed-circuit board for applications such as PC cameras, surveillance cameras, camcorders and digital still cameras, care should be taken to minimize the noise.

For the front-end integrated circuit, the basic rules of printed-circuit board design and implementation of analog components (such as additional operational amplifiers) must be respected, particularly with respect to power and ground connections.

The following additional recommendation is given for the CDS input pin(s) which is /are internally connected to the programmable gain amplifier.

The connections between the CCD interface and CDS input should be as short as possible and a ground ring protection around these connections can be beneficial. Separate analog and digital supplies provide the best solution. If this is not possible to do this on the board then the analog supply pins must be decoupled effectively from the digital supply pins. If the same power supply and ground are used for all the pins then the decoupling capacitors must be placed as close as possible to the IC package.

In order to minimize the noise due to package and die parasitics in a two-ground system, the following measures must be implemented:

- All the analog and digital supply pins must be decoupled to the analog ground plane. Only the ground pin associated with the digital outputs must be connected to the digital ground plane. All the other ground pins should be connected to the analog ground plane. The analog and digital ground planes must be connected together at one point as close as possible to the ground pin associated with the digital outputs.
- The digital output pins and their associated lines should be shielded by the digital ground plane which can then be used as a return path for digital signals.

# 10-bit, 3.0 V, up to 18 Msp/s analog-to-digital interface for CCD cameras

TDA8787A

## Application diagram

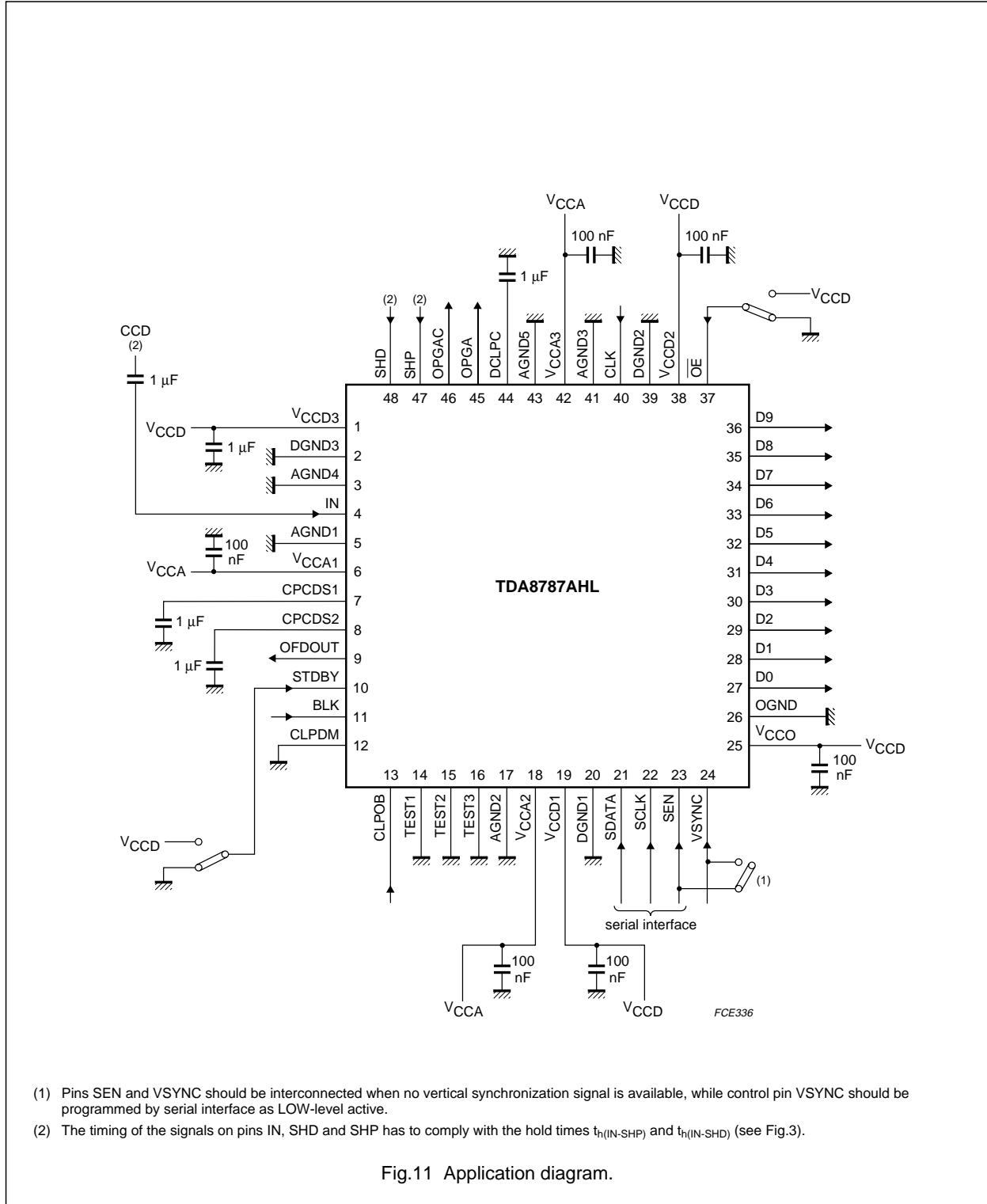

10-bit, 3.0 V, up to 18 Msp/s analog-to-digital interface for CCD cameras

TDA8787A

PACKAGE OUTLINE

LQFP48: plastic low profile quad flat package; 48 leads; body 7 x 7 x 1.4 mm

SOT313-2

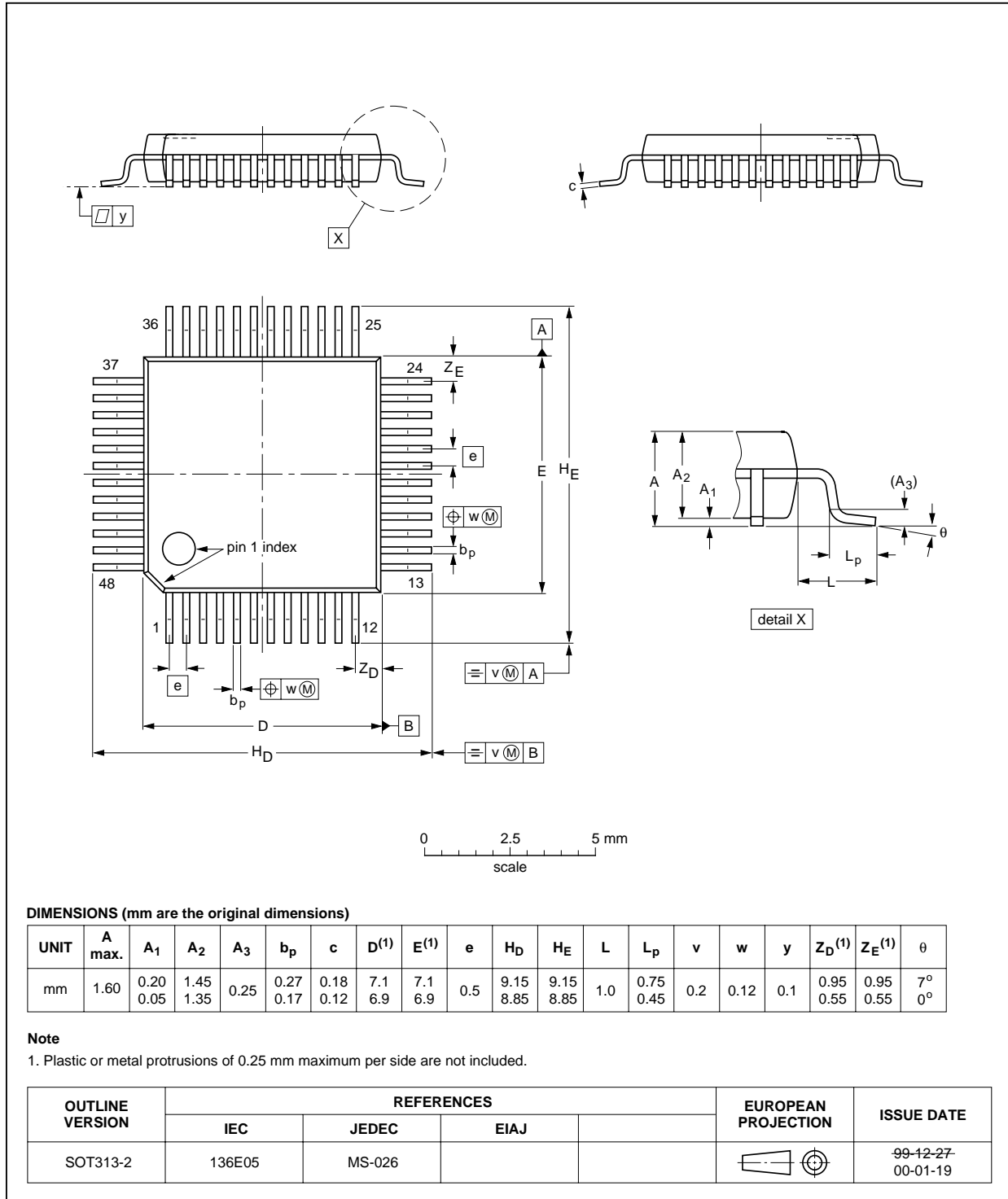

# 10-bit, 3.0 V, up to 18 Msps analog-to-digital interface for CCD cameras

TDA8787A

## SOLDERING

### Introduction to soldering surface mount packages

This text gives a very brief insight to a complex technology. A more in-depth account of soldering ICs can be found in our *"Data Handbook IC26; Integrated Circuit Packages"* (document order number 9398 652 90011).

There is no soldering method that is ideal for all surface mount IC packages. Wave soldering can still be used for certain surface mount ICs, but it is not suitable for fine pitch SMDs. In these situations reflow soldering is recommended.

### Reflow soldering

Reflow soldering requires solder paste (a suspension of fine solder particles, flux and binding agent) to be applied to the printed-circuit board by screen printing, stencilling or pressure-syringe dispensing before package placement.

Several methods exist for reflowing; for example, convection or convection/infrared heating in a conveyor type oven. Throughput times (preheating, soldering and cooling) vary between 100 and 200 seconds depending on heating method.

Typical reflow peak temperatures range from 215 to 250 °C. The top-surface temperature of the packages should preferably be kept below 220 °C for thick/large packages, and below 235 °C for small/thin packages.

### Wave soldering

Conventional single wave soldering is not recommended for surface mount devices (SMDs) or printed-circuit boards with a high component density, as solder bridging and non-wetting can present major problems.

To overcome these problems the double-wave soldering method was specifically developed.

If wave soldering is used the following conditions must be observed for optimal results:

- Use a double-wave soldering method comprising a turbulent wave with high upward pressure followed by a smooth laminar wave.
- For packages with leads on two sides and a pitch (e):
  - larger than or equal to 1.27 mm, the footprint longitudinal axis is **preferred** to be parallel to the transport direction of the printed-circuit board;
  - smaller than 1.27 mm, the footprint longitudinal axis **must** be parallel to the transport direction of the printed-circuit board.

The footprint must incorporate solder thieves at the downstream end.

- For packages with leads on four sides, the footprint must be placed at a 45° angle to the transport direction of the printed-circuit board. The footprint must incorporate solder thieves downstream and at the side corners.

During placement and before soldering, the package must be fixed with a droplet of adhesive. The adhesive can be applied by screen printing, pin transfer or syringe dispensing. The package can be soldered after the adhesive is cured.

Typical dwell time is 4 seconds at 250 °C.

A mildly-activated flux will eliminate the need for removal of corrosive residues in most applications.

### Manual soldering

Fix the component by first soldering two diagonally-opposite end leads. Use a low voltage (24 V or less) soldering iron applied to the flat part of the lead. Contact time must be limited to 10 seconds at up to 300 °C.

When using a dedicated tool, all other leads can be soldered in one operation within 2 to 5 seconds between 270 and 320 °C.

# 10-bit, 3.0 V, up to 18 Msps analog-to-digital interface for CCD cameras

TDA8787A

## Suitability of surface mount IC packages for wave and reflow soldering methods

PACKAGE <sup>(1)</sup>	SOLDERING METHOD	
	WAVE	REFLOW <sup>(2)</sup>
BGA, LBGA, LFBGA, SQFP, TFBGA, VFBGA	not suitable	suitable
HBCC, HBGA, HLQFP, HSQFP, HSOP, HTQFP, HTSSOP, HVQFN, HVSON, SMS	not suitable <sup>(3)</sup>	suitable
PLCC <sup>(4)</sup> , SO, SOJ	suitable	suitable
LQFP, QFP, TQFP	not recommended <sup>(4)(5)</sup>	suitable
SSOP, TSSOP, VSO	not recommended <sup>(6)</sup>	suitable

### Notes

- For more detailed information on the BGA packages refer to the “(LF)BGA Application Note” (AN01026); order a copy from your Philips Semiconductors sales office.
- All surface mount (SMD) packages are moisture sensitive. Depending upon the moisture content, the maximum temperature (with respect to time) and body size of the package, there is a risk that internal or external package cracks may occur due to vaporization of the moisture in them (the so called popcorn effect). For details, refer to the Drypack information in the “Data Handbook IC26; Integrated Circuit Packages; Section: Packing Methods”.
- These packages are not suitable for wave soldering. On versions with the heatsink on the bottom side, the solder cannot penetrate between the printed-circuit board and the heatsink. On versions with the heatsink on the top side, the solder might be deposited on the heatsink surface.
- If wave soldering is considered, then the package must be placed at a 45° angle to the solder wave direction. The package footprint must incorporate solder thieves downstream and at the side corners.
- Wave soldering is suitable for LQFP, TQFP and QFP packages with a pitch (e) larger than 0.8 mm; it is definitely not suitable for packages with a pitch (e) equal to or smaller than 0.65 mm.
- Wave soldering is suitable for SSOP and TSSOP packages with a pitch (e) equal to or larger than 0.65 mm; it is definitely not suitable for packages with a pitch (e) equal to or smaller than 0.5 mm.

# 10-bit, 3.0 V, up to 18 Msps analog-to-digital interface for CCD cameras

TDA8787A

## DATA SHEET STATUS

LEVEL	DATA SHEET STATUS <sup>(1)</sup>	PRODUCT STATUS <sup>(2)(3)</sup>	DEFINITION
I	Objective data	Development	This data sheet contains data from the objective specification for product development. Philips Semiconductors reserves the right to change the specification in any manner without notice.
II	Preliminary data	Qualification	This data sheet contains data from the preliminary specification. Supplementary data will be published at a later date. Philips Semiconductors reserves the right to change the specification without notice, in order to improve the design and supply the best possible product.
III	Product data	Production	This data sheet contains data from the product specification. Philips Semiconductors reserves the right to make changes at any time in order to improve the design, manufacturing and supply. Relevant changes will be communicated via a Customer Product/Process Change Notification (CPCN).

### Notes

1. Please consult the most recently issued data sheet before initiating or completing a design.
2. The product status of the device(s) described in this data sheet may have changed since this data sheet was published. The latest information is available on the Internet at URL <http://www.semiconductors.philips.com>.
3. For data sheets describing multiple type numbers, the highest-level product status determines the data sheet status.

### DEFINITIONS

**Short-form specification** — The data in a short-form specification is extracted from a full data sheet with the same type number and title. For detailed information see the relevant data sheet or data handbook.

**Limiting values definition** — Limiting values given are in accordance with the Absolute Maximum Rating System (IEC 60134). Stress above one or more of the limiting values may cause permanent damage to the device.

These are stress ratings only and operation of the device at these or at any other conditions above those given in the Characteristics sections of the specification is not implied. Exposure to limiting values for extended periods may affect device reliability.

**Application information** — Applications that are described herein for any of these products are for illustrative purposes only. Philips Semiconductors make no representation or warranty that such applications will be suitable for the specified use without further testing or modification.

### DISCLAIMERS

**Life support applications** — These products are not designed for use in life support appliances, devices, or systems where malfunction of these products can reasonably be expected to result in personal injury. Philips Semiconductors customers using or selling these products for use in such applications do so at their own risk and agree to fully indemnify Philips Semiconductors for any damages resulting from such application.

**Right to make changes** — Philips Semiconductors reserves the right to make changes in the products - including circuits, standard cells, and/or software - described or contained herein in order to improve design and/or performance. When the product is in full production (status 'Production'), relevant changes will be communicated via a Customer Product/Process Change Notification (CPCN). Philips Semiconductors assumes no responsibility or liability for the use of any of these products, conveys no licence or title under any patent, copyright, or mask work right to these products, and makes no representations or warranties that these products are free from patent, copyright, or mask work right infringement, unless otherwise specified.

---

10-bit, 3.0 V, up to 18 Msps analog-to-digital  
interface for CCD cameras

---

TDA8787A

**NOTES**

# ***Philips Semiconductors – a worldwide company***

## **Contact information**

For additional information please visit <http://www.semiconductors.philips.com>. Fax: **+31 40 27 24825**

For sales offices addresses send e-mail to: [sales.addresses@www.semiconductors.philips.com](mailto:sales.addresses@www.semiconductors.philips.com).

© Koninklijke Philips Electronics N.V. 2002

SCA74

All rights are reserved. Reproduction in whole or in part is prohibited without the prior written consent of the copyright owner.

The information presented in this document does not form part of any quotation or contract, is believed to be accurate and reliable and may be changed without notice. No liability will be accepted by the publisher for any consequence of its use. Publication thereof does not convey nor imply any license under patent- or other industrial or intellectual property rights.

Printed in The Netherlands

753504/04/pp24

Date of release: 2002 Oct 25

Document order number: 9397 750 10096

*Let's make things better.*

**Philips  
Semiconductors**



**PHILIPS**