

# DATA SHEET

**TDA8709A**

Video analog input interface

Product specification  
Supersedes data of April 1993  
File under Integrated Circuits, IC02

June 1994

**Philips Semiconductors**



**PHILIPS**

## Video analog input interface

## TDA8709A

### FEATURES

- 8-bit resolution
- Sampling rate up to 32 MHz
- TTL-compatible digital inputs and outputs
- Internal reference voltage regulator
- Low-level AC clock inputs and outputs
- Clamp function with selection for '16' or '128'
- No sample-and-hold circuit required
- Three selectable video inputs.

### APPLICATIONS

- Video signal processing
- Digital picture processing
- Frame grabbing.
- Colour difference signals (U, V)
- R, G, B signals
- Chrominance signal (C).

### GENERAL DESCRIPTION

The TDA8709A is an analog input interface for video signal processing. It includes a an input selector (one out-of-three video signals), video amplifier with clamp and external gain control, an 8-bit analog-to-digital converter (ADC) with a sampling rate of 32 MHz and an input selector.

### QUICK REFERENCE DATA

SYMBOL	PARAMETER	MIN.	TYP.	MAX.	UNIT
V <sub>CCA</sub>	analog supply voltage	4.5	5.0	5.5	V
V <sub>CCD</sub>	digital supply voltage	4.5	5.0	5.5	V
V <sub>CCO</sub>	TTL output supply voltage	4.2	5.0	5.5	V
I <sub>CCA</sub>	analog supply current	–	40	47	mA
I <sub>CCD</sub>	digital supply current	–	24	30	mA
I <sub>CCO</sub>	TTL output supply current	–	12	16	mA
ILE	DC integral linearity error	–	–	±1	LSB
DLE	DC differential linearity error	–	–	±0.5	LSB
f <sub>clk(max)</sub>	maximum clock frequency	30	32	–	MHz
B	maximum –3 dB bandwidth (preamplifier)	12	18	–	MHz
P <sub>tot</sub>	total power dissipation	–	380	512	mW

### ORDERING INFORMATION

TYPE NUMBER	PACKAGE			
	PINS	PIN POSITION	MATERIAL	CODE
TDA8709A	28	DIP	plastic	SOT117-1
TDA8709AT	28	SO28L	plastic	SOT136-1

Video analog input interface

TDA8709A

BLOCK DIAGRAM

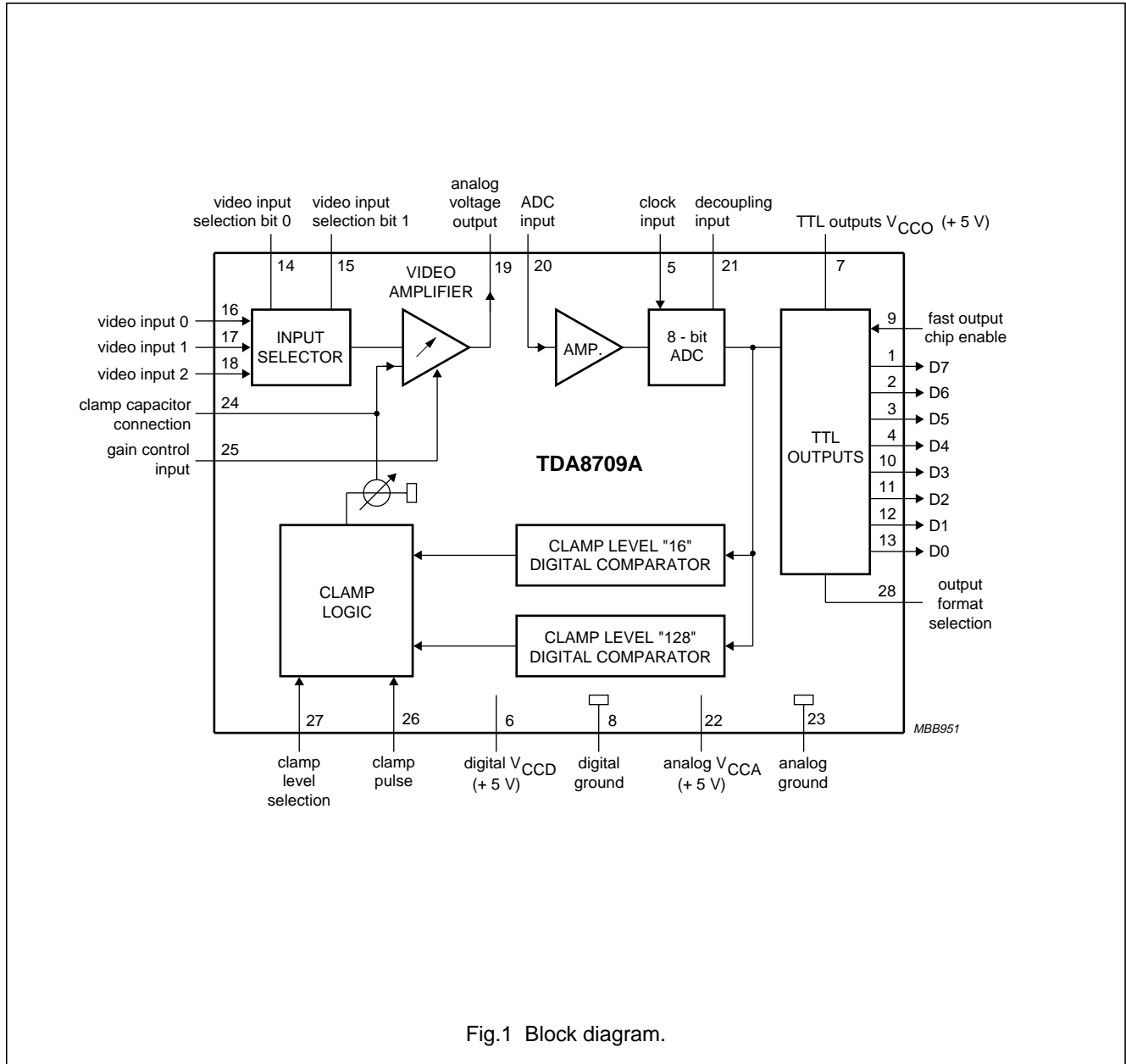

Fig.1 Block diagram.

Video analog input interface

TDA8709A

PINNING

SYMBOL	PIN	DESCRIPTION
D7	1	data output; bit 7 (MSB)
D6	2	data output; bit 6
D5	3	data output; bit 5
D4	4	data output; bit 4
CLK	5	clock input
V <sub>CCD</sub>	6	digital supply voltage (+5 V)
V <sub>CCO</sub>	7	TTL outputs supply voltage (+5 V)
DGND	8	digital ground
FOEN	9	fast output chip enable
D3	10	data output; bit 3
D2	11	data output; bit 2
D1	12	data output; bit 1
D0	13	data output; bit 0 (LSB)
I0	14	video input selection bit 0
I1	15	video input selection bit 1
VIN0	16	video input 0
VIN1	17	video input 1
VIN2	18	video input 2
ANOUT	19	analog voltage output
ADCIN	20	analog-to-digital converter input
DEC	21	decoupling input
V <sub>CCA</sub>	22	analog supply voltage (+5 V)
AGND	23	analog ground
CLAMP	24	clamp capacitor connection
GAIN	25	gain control input
CLP	26	clamping pulse
CLS	27	clamping level selection input
OFS	28	output format selection

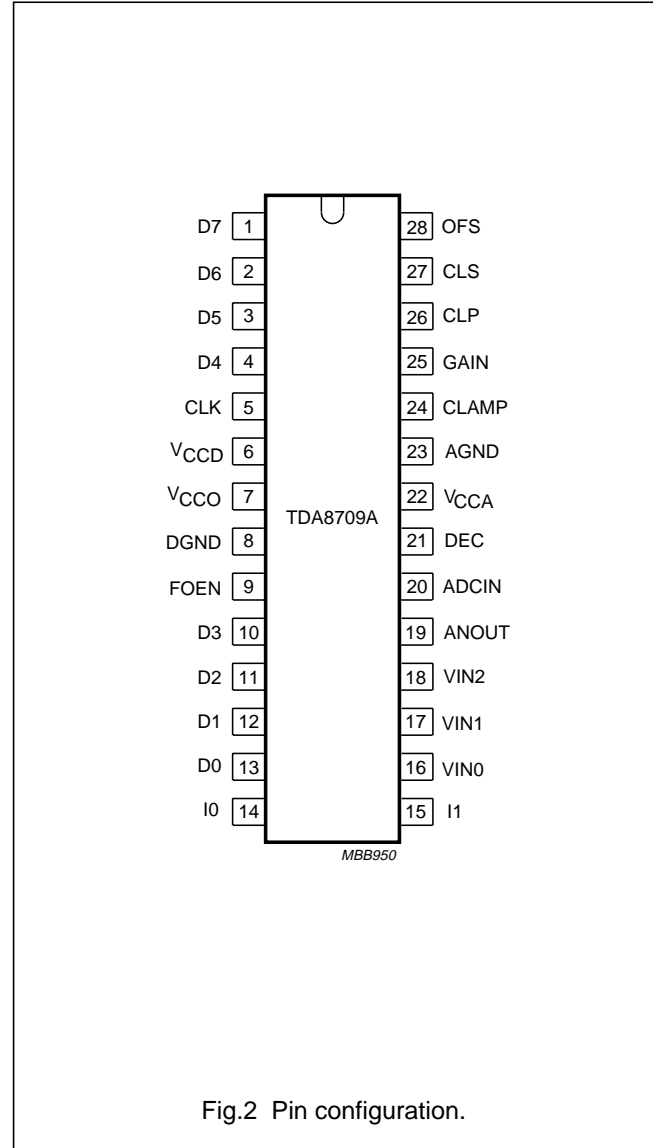

Fig.2 Pin configuration.

## Video analog input interface

## TDA8709A

**FUNCTIONAL DESCRIPTION**

TDA8709A is an 8-bit ADC with internal clamping and a preamplifier with adjustable gain.

The clamping value is switched via pin 27 between digital 16 (for R, G, B signals) and digital 128 (for

chrominance or colour difference signals). While clamping pulse at pin 27 is logic 1, the device will adjust the clamping level to the chosen value. The output format can be selected between binary and two's complement at pin 28.

**LIMITING VALUES**

In accordance with the Absolute Maximum Rating System (IEC 134).

SYMBOL	PARAMETER	MIN.	MAX.	UNIT
$V_{CCA}$	analog supply voltage	-0.3	+7.0	V
$V_{CCD}$	digital supply voltage	-0.3	+7.0	V
$V_{CCO}$	TTL output supply voltage	-0.3	+7.0	V
$\Delta V_{CC}$	supply voltage difference between $V_{CCA}$ and $V_{CCD}$	-0.5	+0.5	V
	supply voltage difference between $V_{CCO}$ and $V_{CCD}$	-0.5	+0.5	V
	supply voltage difference between $V_{CCA}$ and $V_{CCO}$	-1.0	+1.0	V
$V_I$	input voltage	-0.3	+7.0	V
$I_O$	output current	-	+10	mA
$T_{stg}$	storage temperature	-55	+150	°C
$T_{amb}$	operating ambient temperature	0	+70	°C
$T_j$	junction temperature	0	+125	°C

**THERMAL CHARACTERISTICS**

SYMBOL	PARAMETER	VALUE	UNIT
$R_{th\ j-a}$	thermal resistance from junction to ambient in free air		
	SOT117-1	55	K/W
	SOT136-1	70	K/W

## Video analog input interface

## TDA8709A

**CHARACTERISTICS**

$V_{CCA} = V_{22}$  to  $V_{23} = 4.5$  to  $5.5$  V;  $V_{CCD} = V_6$  to  $V_8 = 4.5$  to  $5.5$  V;  $V_{CCO} = V_7$  to  $V_8 = 4.2$  to  $5.5$  V; AGND and DGND shorted together;  $V_{CCA}$  to  $V_{CCD} = -0.5$  to  $+0.5$  V;  $V_{CCO}$  to  $V_{CCD} = -0.5$  to  $+0.5$  V;  $V_{CCA}$  to  $V_{CCO} = -0.5$  to  $+0.5$  V;  $T_{amb} = 0$  to  $+70$  °C; typical readings taken at  $V_{CCA} = V_{CCD} = V_{CCO} = 5$  V and  $T_{amb} = 25$  °C; unless otherwise specified.

SYMBOL	PARAMETER	CONDITIONS	MIN.	TYP.	MAX.	UNIT
<b>Supplies</b>						
$V_{CCA}$	analog supply voltage		4.5	5.0	5.5	V
$V_{CCD}$	digital supply voltage		4.5	5.0	5.5	V
$V_{CCO}$	TTL output supply voltage		4.2	5.0	5.5	V
$I_{CCA}$	analog supply current		–	40	47	mA
$I_{CCD}$	digital supply current		–	24	30	mA
$I_{CCO}$	TTL output supply current	TTL load (see Fig.7)	–	12	16	mA
<b>Preamplifier inputs</b>						
VIN0 TO VIN2 INPUTS						
$V_{I(p-p)}$	input voltage (peak-to-peak value)	note 1	0.6	–	1.5	V
$ Z_i $	input impedance	$f_i = 6$ MHz	10	20	–	k $\Omega$
$C_i$	input capacitance	$f_i = 6$ MHz	–	1	–	pF
I0 AND I1 TTL INPUTS (SEE TABLE 1)						
$V_{IL}$	LOW level input voltage		0	–	0.8	V
$V_{IH}$	HIGH level input voltage		2.0	–	$V_{CCD}$	V
$I_{IL}$	LOW level input current	$V_I = 0.4$ V	–400	–	–	$\mu$ A
$I_{IH}$	HIGH level input current	$V_I = 2.7$ V	–	–	20	$\mu$ A
CLS, OFS AND CLP TTL INPUTS (SEE FIG.5)						
$V_{IL}$	LOW level input voltage		0	–	0.8	V
$V_{IH}$	HIGH level input voltage		2.0	–	$V_{CCD}$	V
$I_{IL}$	LOW level input current	$V_I = 0.4$ V	–400	–	–	$\mu$ A
$I_{IH}$	HIGH level input current	$V_I = 2.7$ V	–	–	20	$\mu$ A
$t_{CLP}$	clamp pulse width		2	–	–	$\mu$ s
GAIN INPUT (PIN 25)						
$V_{25(min)}$	input voltage for minimum gain	see Fig.9	–	1.8	–	V
$V_{25(max)}$	input voltage for maximum gain	see Fig.9	–	3.8	–	V
$I_i$	input current		–	1.0	–	$\mu$ A
CLAMP INPUT (PIN 24)						
$V_{24}$	clamp voltage for code 128 output		–	3.5	–	V
$I_{24}$	clamp output current		see Table 2			

## Video analog input interface

## TDA8709A

SYMBOL	PARAMETER	CONDITIONS	MIN.	TYP.	MAX.	UNIT
<b>Video amplifier outputs</b>						
ANOUT OUTPUT (PIN 19)						
$V_{19(p-p)}$	AC output voltage (peak-to-peak value)	$V_{OF} = 1.33 \text{ V (p-p)}$ ; $V_{25} = 3.0 \text{ V}$	–	1.33	–	V
$I_{19}$	internal current source	$R_L = \infty$	2.0	2.5	–	mA
$I_{O(p-p)}$	output current driven by the load	$V_{ANOUT} = 1.33 \text{ V (p-p)}$ ; note 2	–	–	1.0	mA
$V_{19}$	DC output voltage for black level	CLS = logic 1	–	$V_{CCA} - 2.02$	–	V
$V_{19}$	DC output voltage for black level	CLS = logic 0	–	$V_{CCA} - 2.6$	–	V
$Z_{19}$	output impedance		–	20	–	$\Omega$
<b>Preamplifier dynamic characteristics</b>						
$\alpha_{ct}$	crosstalk between VIN inputs	$V_{CCA} = 4.75 \text{ to } 5.25 \text{ V}$ ; note 3	–	–50	–45	dB
$G_{diff}$	differential gain	$V_{VIN} = 1.33 \text{ V (p-p)}$ ; $V_{25} = 3.0 \text{ V}$	–	2	–	%
$\phi_{diff}$	differential phase	$V_{VIN} = 1.33 \text{ V (p-p)}$ ; $V_{25} = 3.0 \text{ V}$	–	0.8	–	deg
B	–3 dB bandwidth		12	–	–	MHz
S/N	signal-to-noise ratio	note 4	60	–	–	dB
SVRR1	supply voltage ripple rejection	note 5	–	45	–	dB
$\Delta G$	gain range	see Fig.9	–4.5	–	+6.0	dB
$G_{stab}$	gain stability as a function of supply voltage and temperature	see Fig.9	–	–	5	%
<b>Analog-to-digital converter inputs</b>						
CLK INPUT (PIN 5)						
$V_{IL}$	LOW level input voltage		0	–	0.8	V
$V_{IH}$	HIGH level input voltage		2.0	–	$V_{CCD}$	V
$I_{IL}$	LOW level input current	$V_{clk} = 0.4 \text{ V}$	–400	–	–	$\mu\text{A}$
$I_{IH}$	HIGH level input current	$V_{clk} = 2.7 \text{ V}$	–	–	100	$\mu\text{A}$
$ Z_i $	input impedance	$f_{clk} = 10 \text{ MHz}$	–	4	–	$\text{k}\Omega$
$C_i$	input capacitance	$f_{clk} = 10 \text{ MHz}$	–	4.5	–	pF
FOEN INPUT (SEE TABLE 3)						
$V_{IL}$	LOW level input voltage		0	–	0.8	V
$V_{IH}$	HIGH level input voltage		2.0	–	$V_{CCD}$	V
$I_{IL}$	LOW level input current	$V_g = 0.4 \text{ V}$	–400	–	–	$\mu\text{A}$
$I_{IH}$	HIGH level input current	$V_g = 2.7 \text{ V}$	–	–	20	$\mu\text{A}$

## Video analog input interface

## TDA8709A

SYMBOL	PARAMETER	CONDITIONS	MIN.	TYP.	MAX.	UNIT
<b>ADCIN INPUT (PIN 20; SEE TABLE 4)</b>						
V <sub>20</sub>	input voltage	digital output = 00	–	V <sub>CCA</sub> – 2.52	–	V
V <sub>20</sub>	input voltage	digital output = 255	–	V <sub>CCA</sub> – 1.52	–	V
V <sub>20(p-p)</sub>	input voltage amplitude (peak-to-peak value)		–	1.0	–	V
I <sub>20</sub>	input current		–	1.0	10	μA
Z <sub>i</sub>	input impedance	f <sub>i</sub> = 6 MHz	–	50	–	MΩ
C <sub>1</sub>	input capacitance	f <sub>i</sub> = 6 MHz	–	1	–	pF
<b>Analog-to-digital converter outputs</b>						
DIGITAL OUTPUTS D0 TO D7						
V <sub>OL</sub>	LOW level output voltage	I <sub>OL</sub> = 2 mA	0	–	0.6	V
V <sub>OH</sub>	HIGH level output voltage	I <sub>OL</sub> = –0.4 mA	2.4	–	V <sub>CCD</sub>	V
I <sub>OZ</sub>	output current in 3-state mode	0.4 V < V <sub>O</sub> < V <sub>CCD</sub>	–20	–	+20	μA
<b>Switching characteristics</b>						
f <sub>clk(max)</sub>	maximum clock input frequency	see Fig.5; note 6	30	32	–	MHz
<b>Analog signal processing (f<sub>clk</sub> = 32 MHz; see Fig.7)</b>						
G <sub>diff</sub>	differential gain	V <sub>20</sub> = 1.0 V (p-p); see Fig.6; note 7	–	2	–	%
Φ <sub>diff</sub>	differential phase	see Fig.6; note 7	–	2	–	deg
f <sub>1</sub>	fundamental harmonics (full-scale)	f <sub>i</sub> = 4.43 MHz; note 7	–	–	0	dB
f <sub>all</sub>	harmonics (full-scale); all components	f <sub>i</sub> = 4.43 MHz; note 7	–	–55	–	dB
SVRR2	supply voltage ripple rejection	note 8	–	1	5	%/V
<b>Transfer function</b>						
ILE	DC integral linearity error		–	–	±1	LSB
DLE	DC differential linearity error		–	–	±0.5	LSB
ILE	AC integral linearity error	note 9	–	–	±2	LSB
<b>Timing (f<sub>clk</sub> = 32 MHz; see Figs 5, 6 and 7)</b>						
DIGITAL OUTPUTS (C <sub>L</sub> = 15 pF; I <sub>OL</sub> = 2 mA; R <sub>L</sub> = 2 kΩ)						
t <sub>ds</sub>	sampling delay time		–	2	–	ns
t <sub>h</sub>	output hold time		–	8	–	ns
t <sub>d</sub>	output delay time		–	16	20	ns
t <sub>dEZ</sub>	3-state delay time; output enable		–	16	25	ns
t <sub>dDZ</sub>	3-state delay time; output disable		–	12	25	ns



## Video analog input interface

## TDA8709A

**Notes to the “Characteristics”**

1. 0 dB is obtained at the AGC amplifier when applying  $V_{i(p-p)} = 1.33$  V.
2. The output current at pin 19 should not exceed 1 mA. The load impedance  $R_L$  should be referenced to  $V_{CCA}$  and defined as:
  - a) AC impedance  $\geq 1$  k $\Omega$  and the DC impedance  $> 2.7$  k $\Omega$ .
  - b) The load impedance should be coupled directly to the output of the amplifier so that the DC voltage supplied by the clamp is not disturbed.
3. Input signals with the same amplitude. Gain is adjusted to obtain  $ANOUT = 1.33$  V (p-p).

4. Signal-to-noise ratio measured with 5 MHz bandwidth:

$$\frac{S}{N} = 20 \log \frac{V_{ANOUT(p-p)}}{V_{ANOUT(RMS\ noise)}} \text{ at } B = 5 \text{ MHz.}$$

5. The voltage ratio is expressed as:

$$SVRR1 = 20 \log \frac{\Delta V_{CCA}}{V_{CCA}} \times \frac{G}{\Delta G} \text{ for } V_I = 1 \text{ V (p-p), gain at 100 kHz} = 1 \text{ and 1 V supply variation.}$$

6. It is recommended that the rise and fall times of the clock are  $\geq 2$  ns. In addition, a ‘good layout’ for the digital and analog grounds is recommended.
7. These measurements are realized on analog signals after a digital-to-analog conversion (TDA8702 is used).
8. The supply voltage rejection is the relative variation of the analog signal (full-scale signal at input) for 1 V of supply variation:

$$SVRR2 = \frac{\Delta (V_{I(00)} - V_{I(FF)}) + (V_{I(00)} - V_{I(FF)})}{\Delta V_{CCA}}$$

9. Full-scale sine wave ( $f_i = 4.4$  MHz;  $f_{clk} = 27$  MHz).

# Video analog input interface

# TDA8709A

**Table 1** Video input selection (CVBS).

I1	I0	SELECTED INPUT
0	0	VIN0
0	1	VIN1
1	0	VIN2
1	1	VIN1

**Table 3** FOEN input coding.

FOEN	D0 TO D7
0	active, two's complement
1	high impedance

**Table 2** CLAMP output current.

CLS	CLP	DIGITAL OUTPUT	I <sub>CLAMP</sub>
1	1	output < 128	+50 μA
		output > 128	-50 μA
X <sup>(1)</sup>	0	X	0 μA
0	1	output < 16	+50 μA
		16 < output	-50 μA

**Note**

1. X = don't care.

**Table 4** Output coding and input voltage (typical values).

STEP	V <sub>ADCIN</sub>	BINARY OUTPUTS								TWO'S COMPLEMENT							
		D7	D6	D5	D4	D3	D2	D1	D0	D7	D6	D5	D4	D3	D2	D1	D0
Underflow	-	0	0	0	0	0	0	0	0	1	0	0	0	0	0	0	0
0	V <sub>CCA</sub> - 2.52 V	0	0	0	0	0	0	0	0	1	0	0	0	0	0	0	0
1	-	0	0	0	0	0	0	0	1	1	0	0	0	0	0	0	1
.	-	.	.	.	.	.	.	.	.	.	.	.	.	.	.	.	.
.	-	.	.	.	.	.	.	.	.	.	.	.	.	.	.	.	.
254	-	1	1	1	1	1	1	1	0	0	1	1	1	1	1	1	0
255	V <sub>CCA</sub> - 1.52 V	1	1	1	1	1	1	1	1	0	1	1	1	1	1	1	1
Overflow	-	1	1	1	1	1	1	1	1	0	1	1	1	1	1	1	1

Video analog input interface

TDA8709A

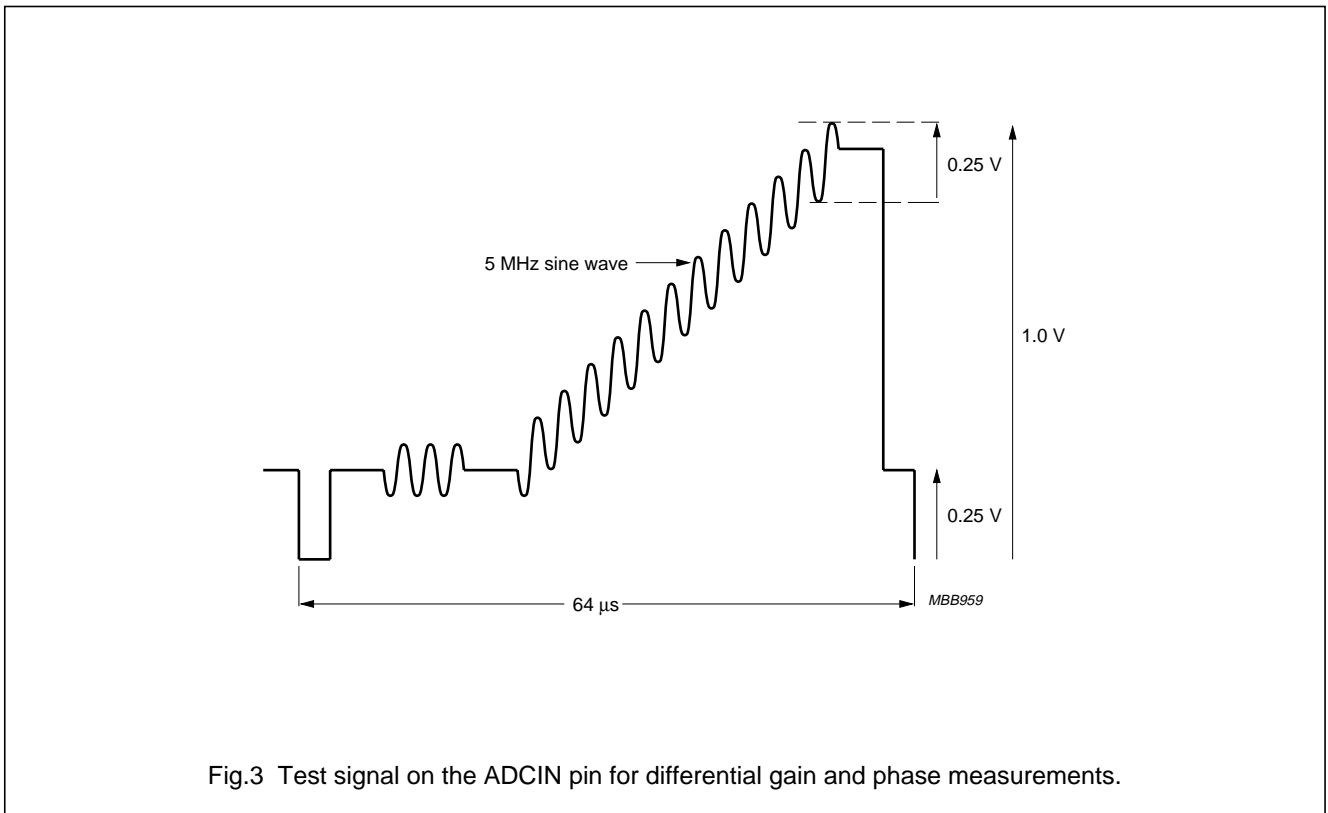

Fig.3 Test signal on the ADCIN pin for differential gain and phase measurements.

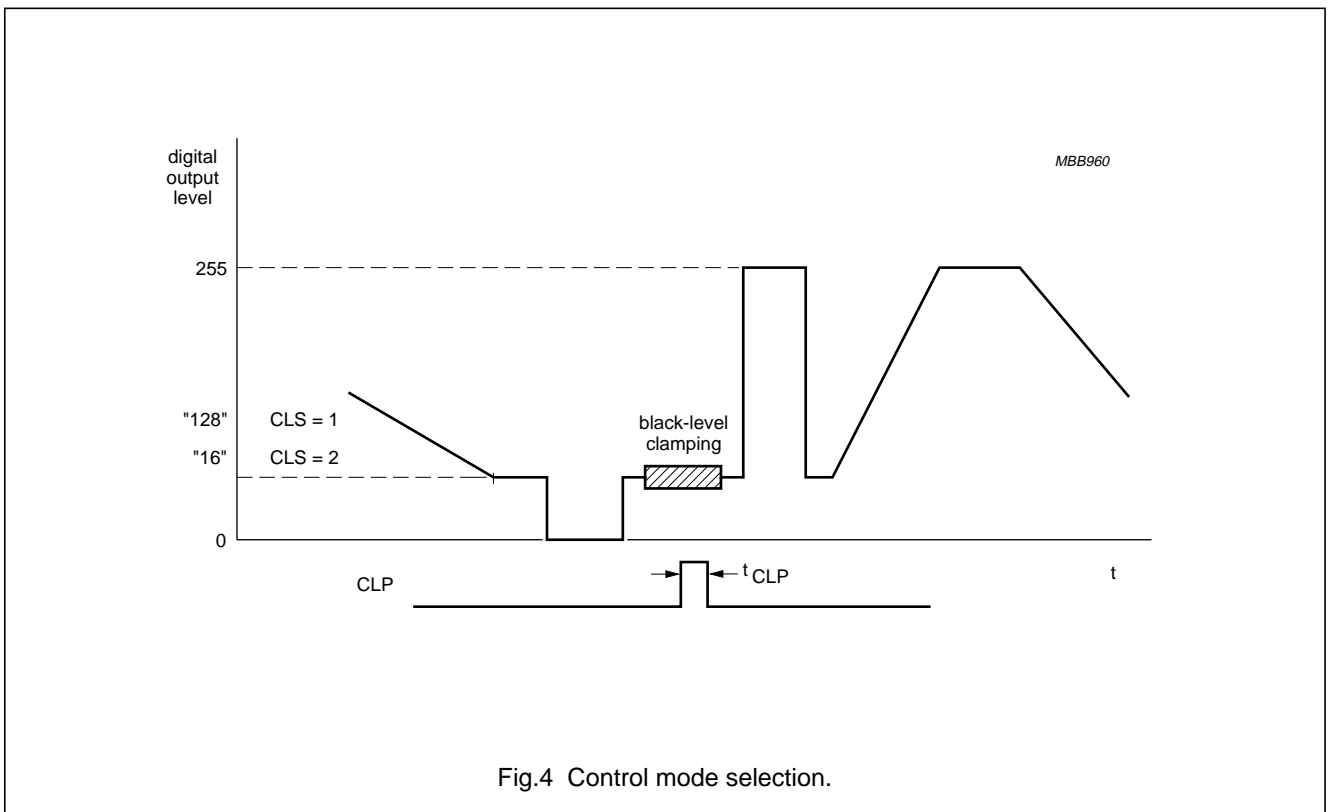

Fig.4 Control mode selection.

Video analog input interface

TDA8709A

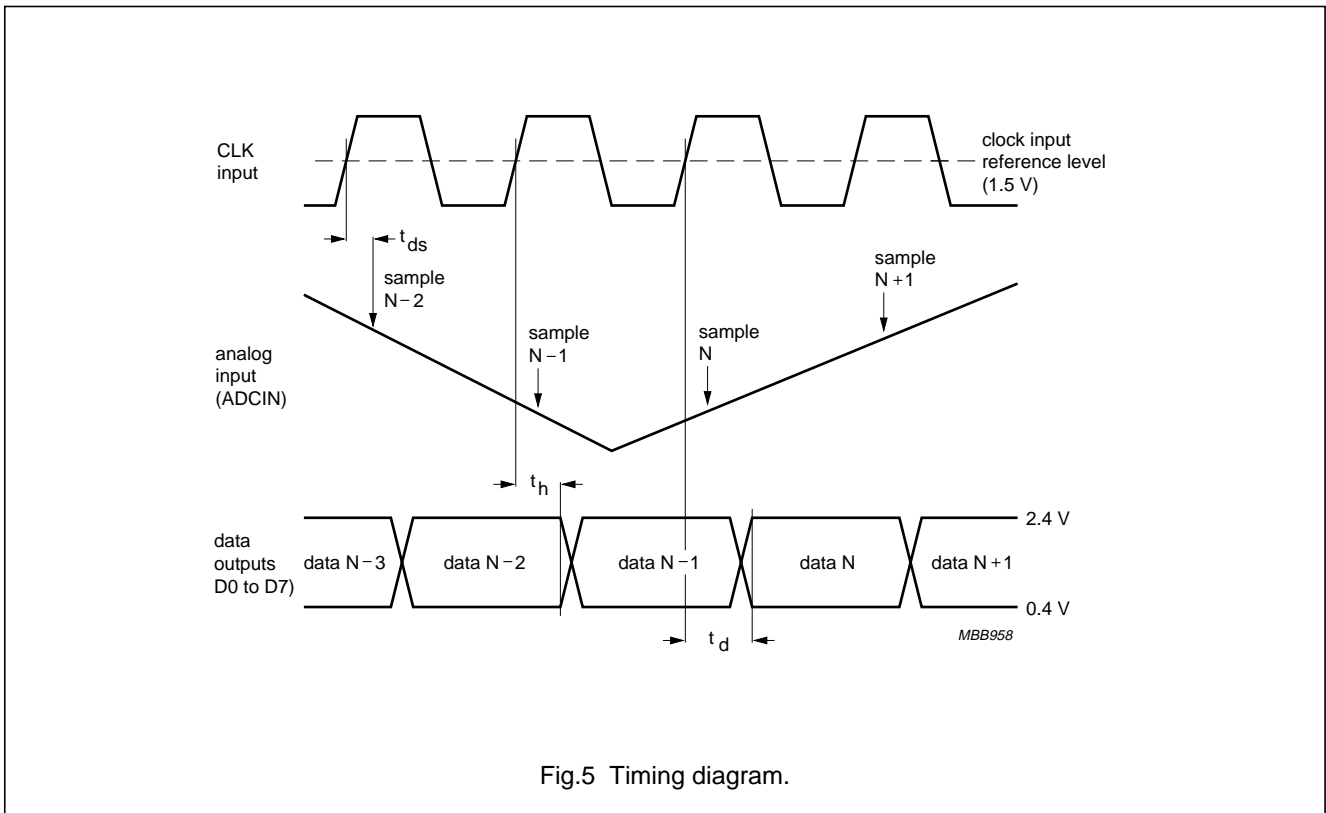

Fig.5 Timing diagram.

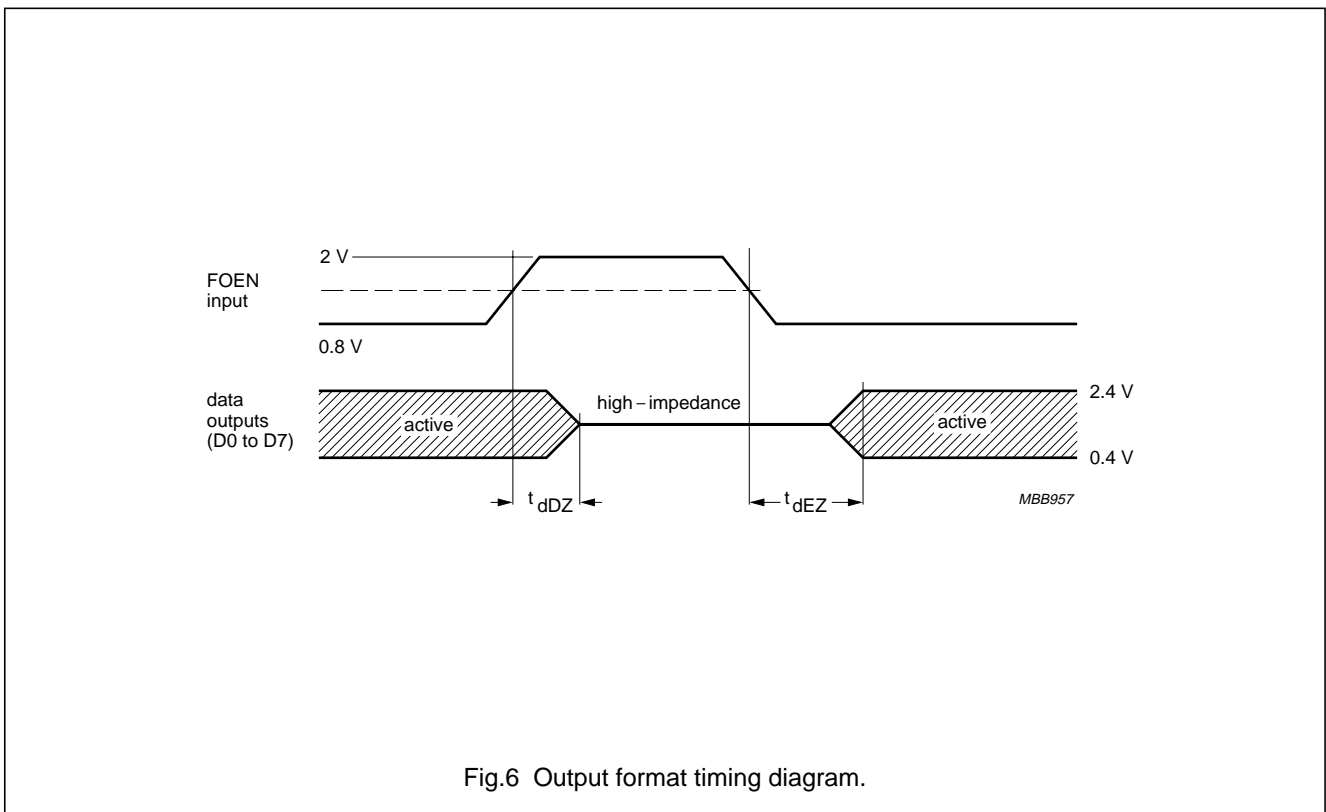
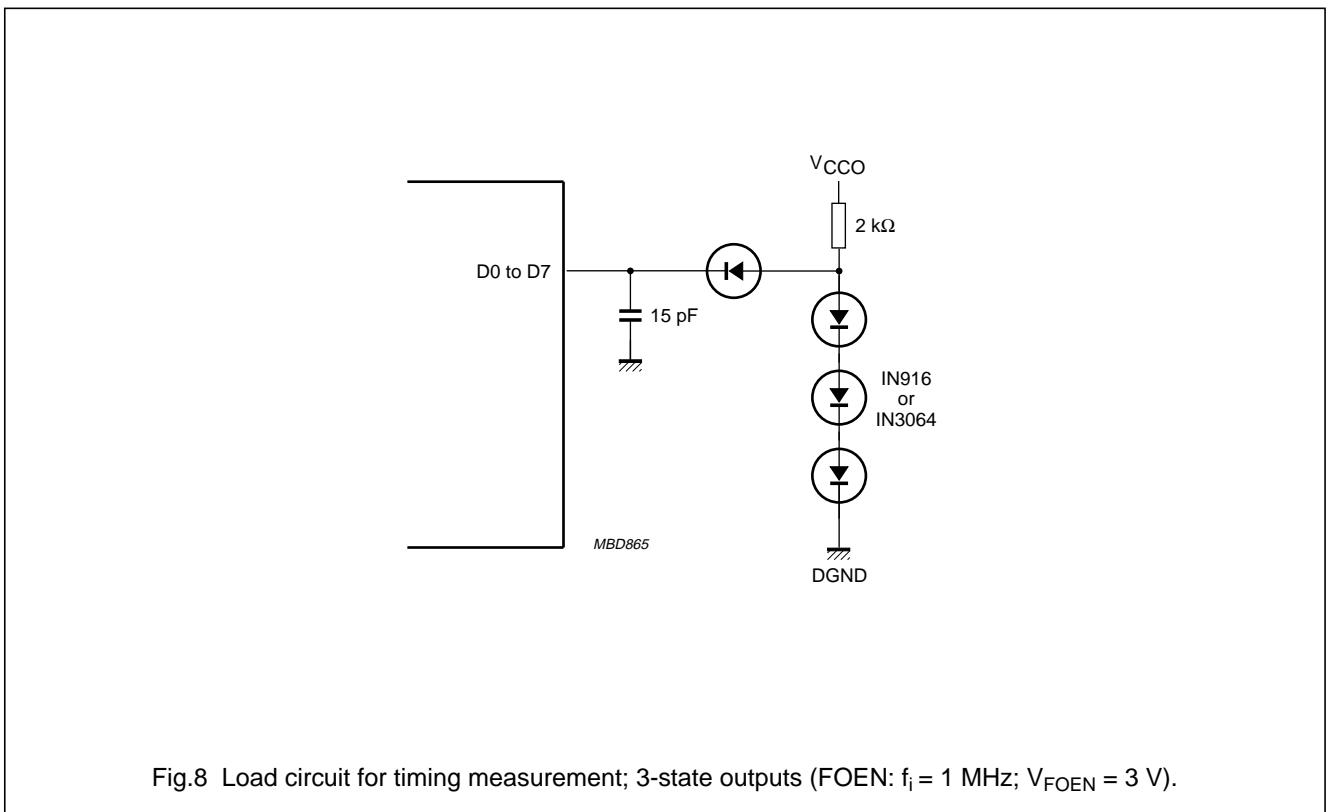
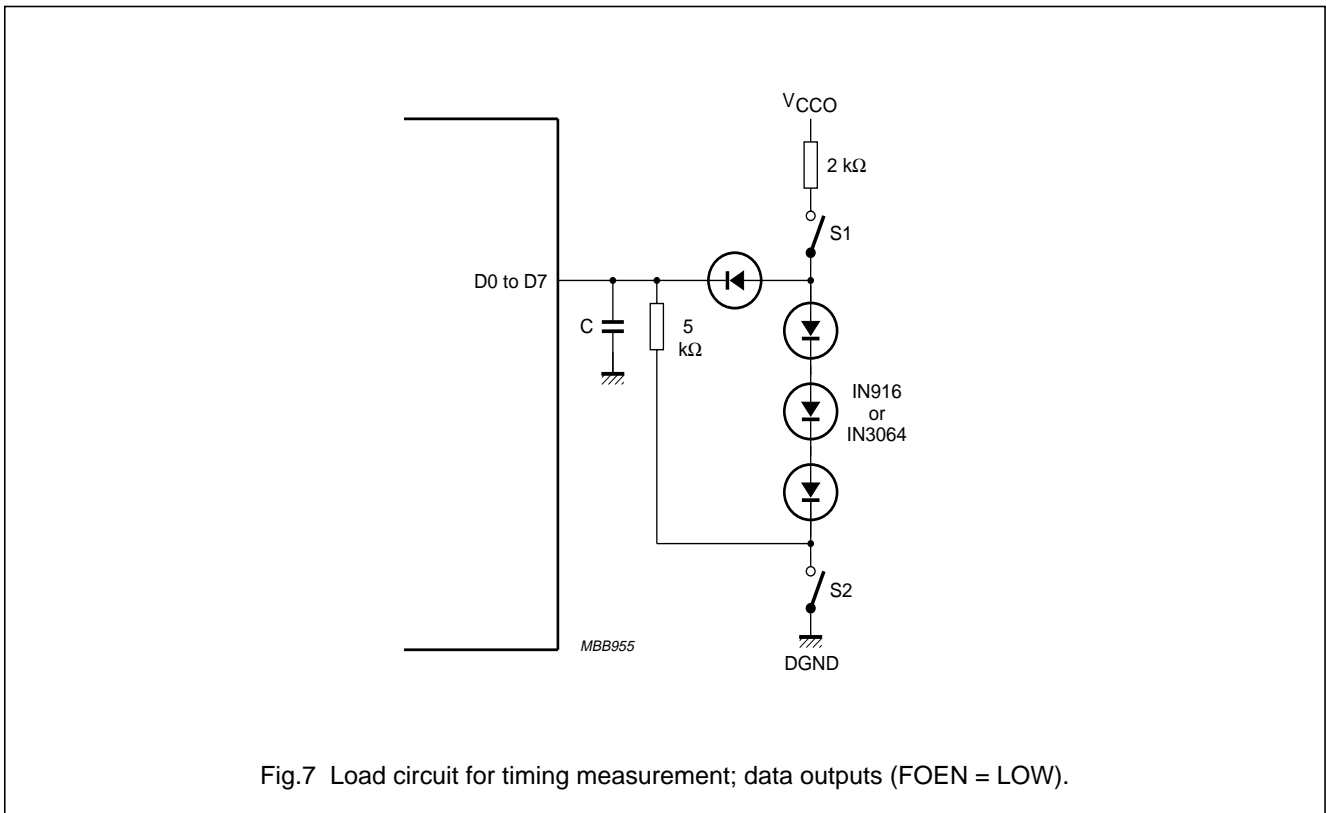

Fig.6 Output format timing diagram.

Video analog input interface

TDA8709A



Video analog input interface

TDA8709A

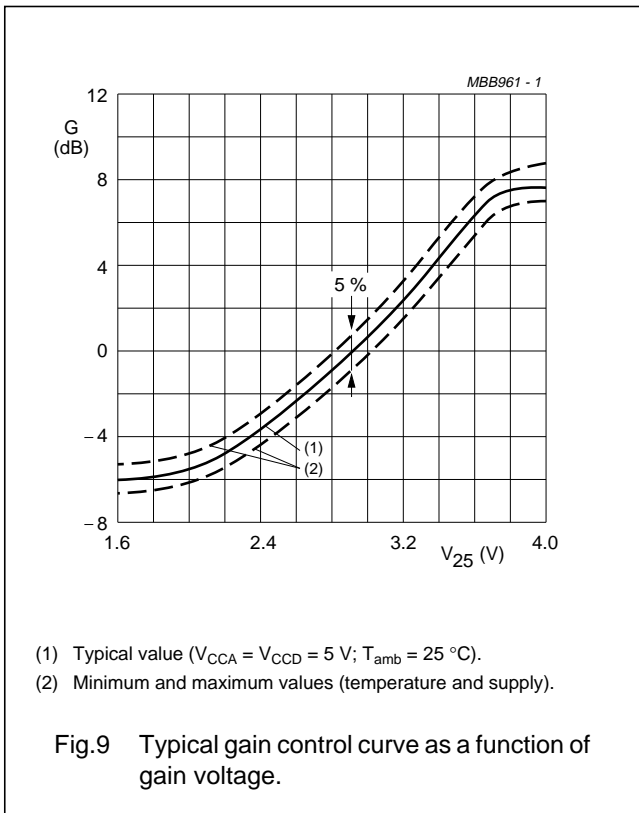

Video analog input interface

TDA8709A

INTERNAL PIN CIRCUITRY

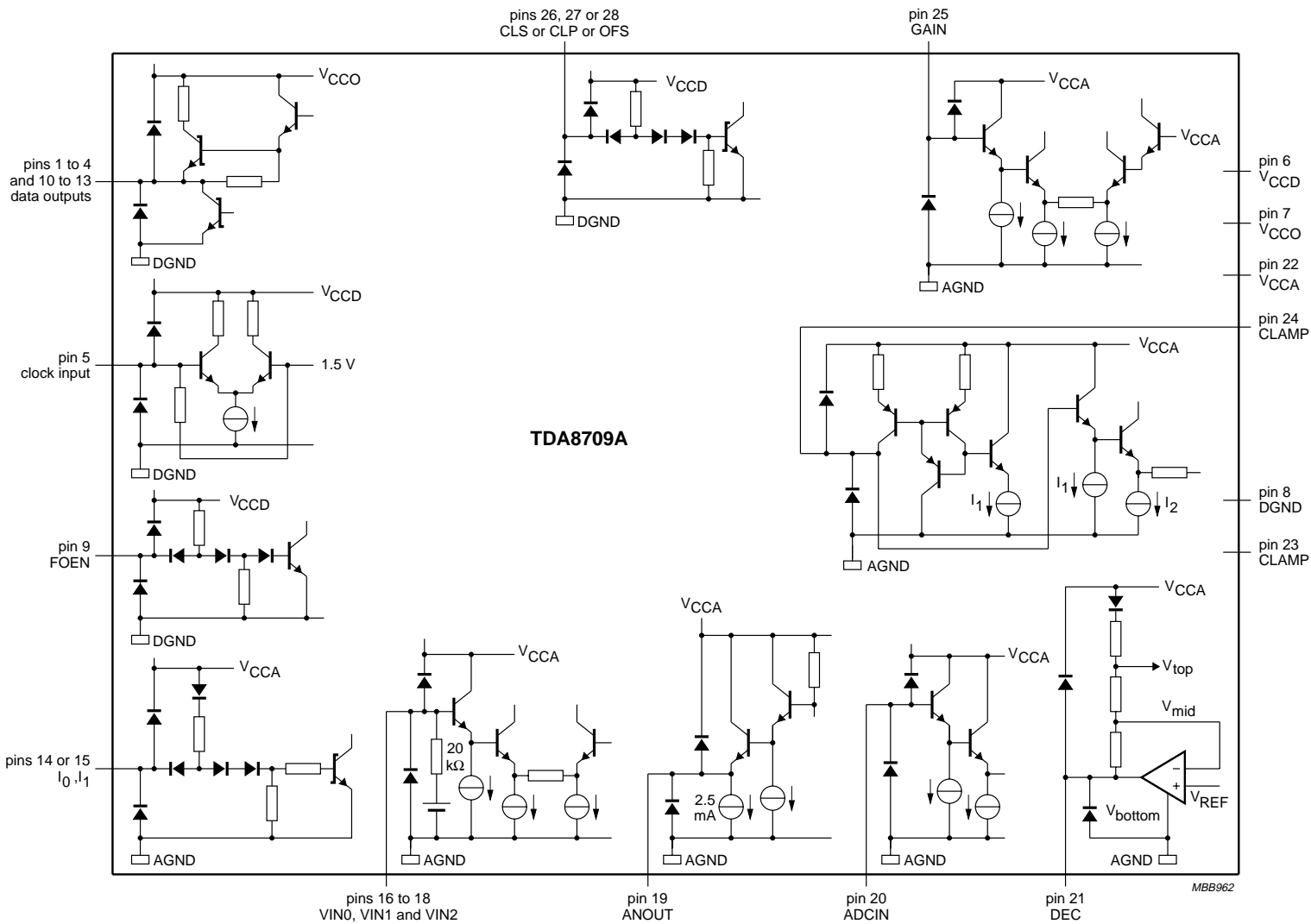

Fig.10 Internal pin configuration.

Video analog input interface

TDA8709A

APPLICATION INFORMATION

Additional information can be found in the laboratory report of TDA8708A "FBL/AN9308".

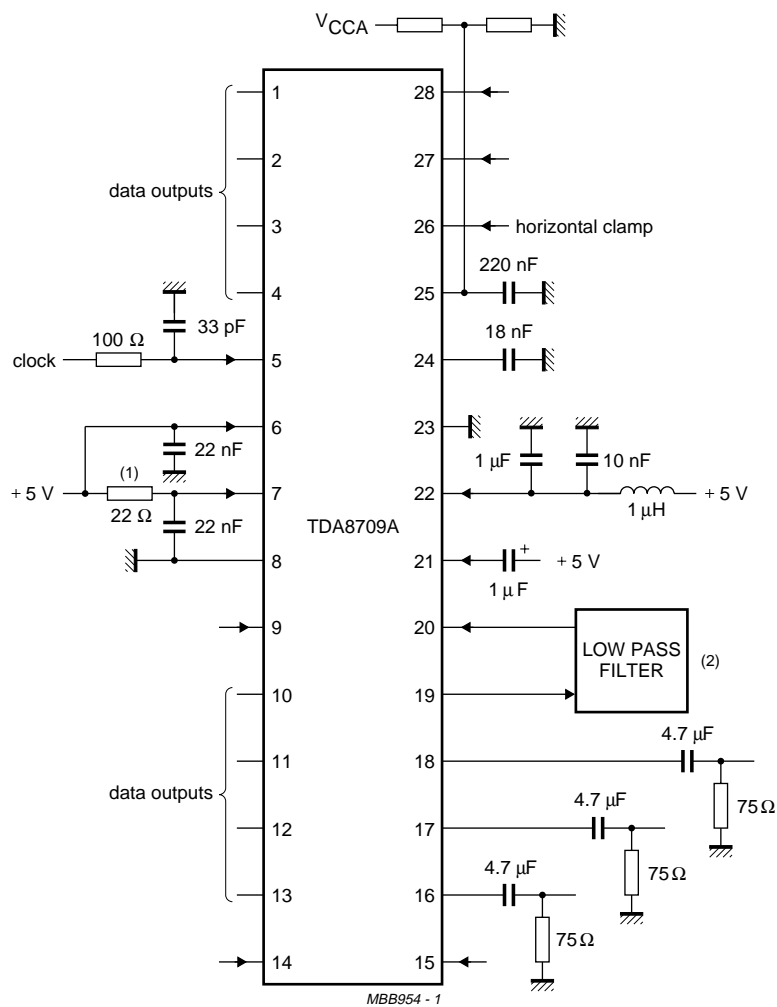

- (1) It is recommended to decouple V<sub>CC0</sub> through a 22 Ω resistor especially when the output data of TDA8709A interfaces with a capacitive CMOS load device.
- (2) See Figs 12, 14, 16 and 18 for examples of the low-pass filters.

Fig.11 Application diagram.



Video analog input interface

TDA8709A

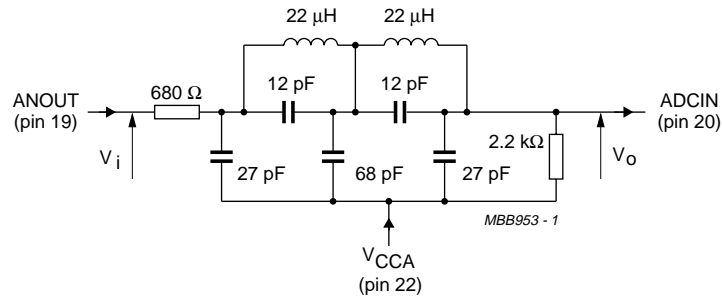

This filter can be adapted to various applications with respect to performance requirements. An input and output impedance of at least 680 Ω and 2.2 kΩ must in any event be applied.

Fig.12 Example of a low-pass filter for RGB and C signals.

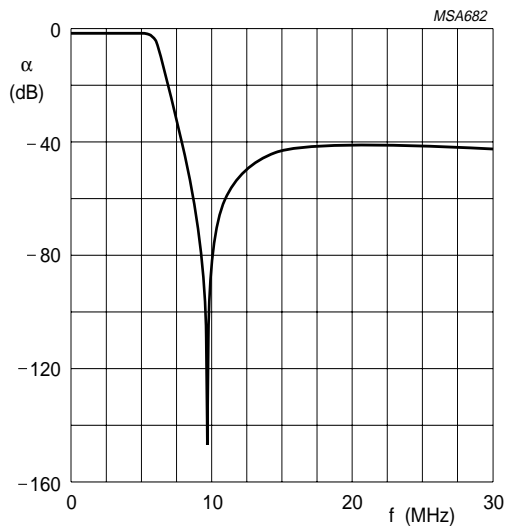

Fig.13 Frequency response for filter shown in Fig.12.

Characteristics of Fig.13

- Order 5; adapted CHEBYSHEV
- Ripple  $p \leq 0.4$  dB
- $f = 6.5$  MHz at  $-3$  dB
- $f_{\text{notch}} = 9.65$  MHz.

Video analog input interface

TDA8709A

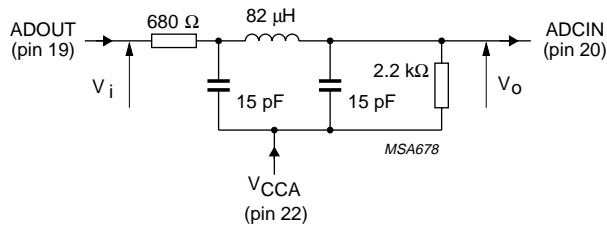

This filter can be adapted to various applications with respect to performance requirements. An input and output impedance of at least 680 Ω and 2.2 kΩ must in any event be applied.

Fig.14 Example of an economical low-pass filter for RGB and C signals.

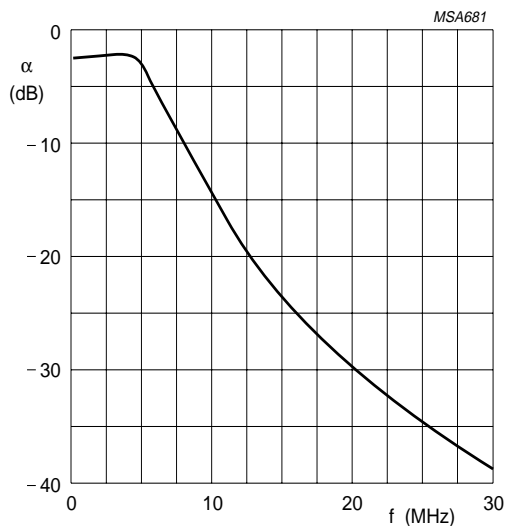

Fig.15 Frequency response for filter shown in Fig.14.

**Characteristics of Fig.15**

- Order 3; adapted CHEBYSHEV
- Ripple  $p \leq 0.4$  dB
- $f = 6.5$  MHz at  $-3$  dB.

Video analog input interface

TDA8709A

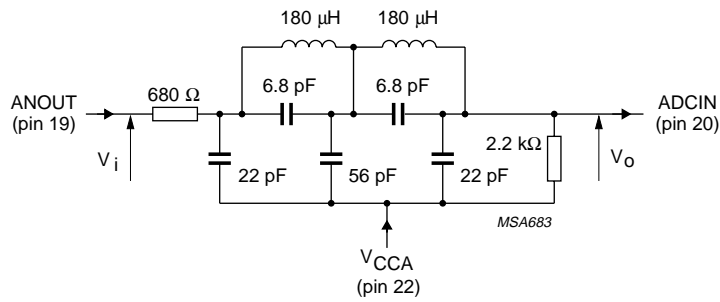

This filter can be adapted to various applications with respect to performance requirements. An input and output impedance of at least 680  $\Omega$  and 2.2 k $\Omega$  must in any event be applied.

Fig.16 Example of a low-pass filter for U and V signals.

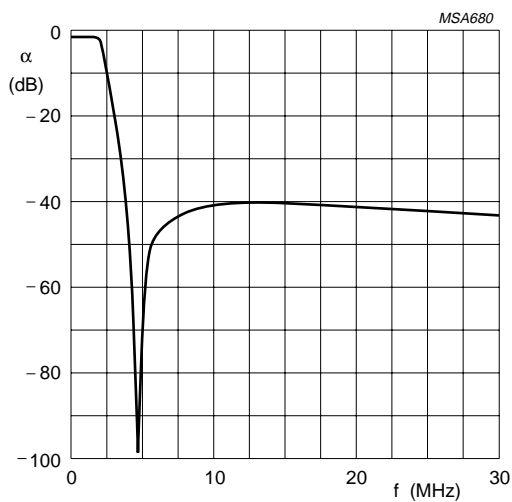

Fig.17 Frequency response for filter shown in Fig.16.

**Characteristics of Fig.17**

- Order 5; adapted CHEBYSHEV
- Ripple  $p \leq 0.4$  dB
- $f = 2.3$  MHz at  $-3$  dB
- $f_{\text{notch}} = 4.5$  MHz.

Video analog input interface

TDA8709A

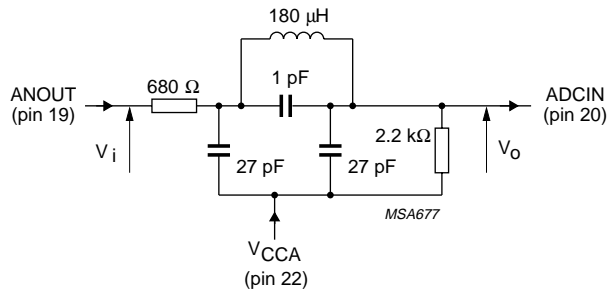

This filter can be adapted to various applications with respect to performance requirements. An input and output impedance of at least 680 Ω and 2.2 kΩ must in any event be applied.

Fig.18 Example of an economical low-pass filter for U and V signals.

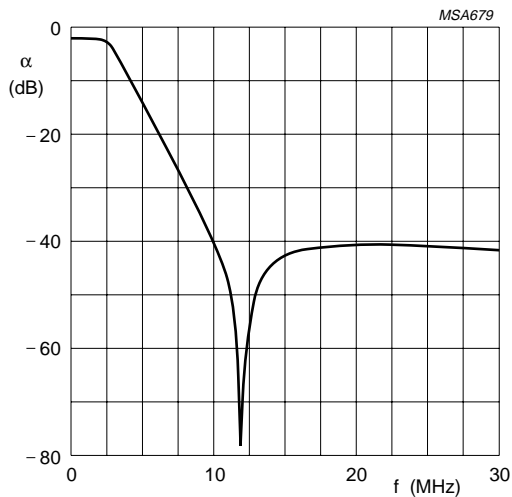

Fig.19 Frequency response for filter shown in Fig.18.

Characteristics of Fig.19

- Order 3; adapted CHEBYSHEV
- Ripple  $p \leq 0.3$  dB
- $f = 2.8$  MHz at  $-3$  dB
- $f_{\text{notch}} = 11.9$  MHz.

Video analog input interface

TDA8709A

PACKAGE OUTLINES

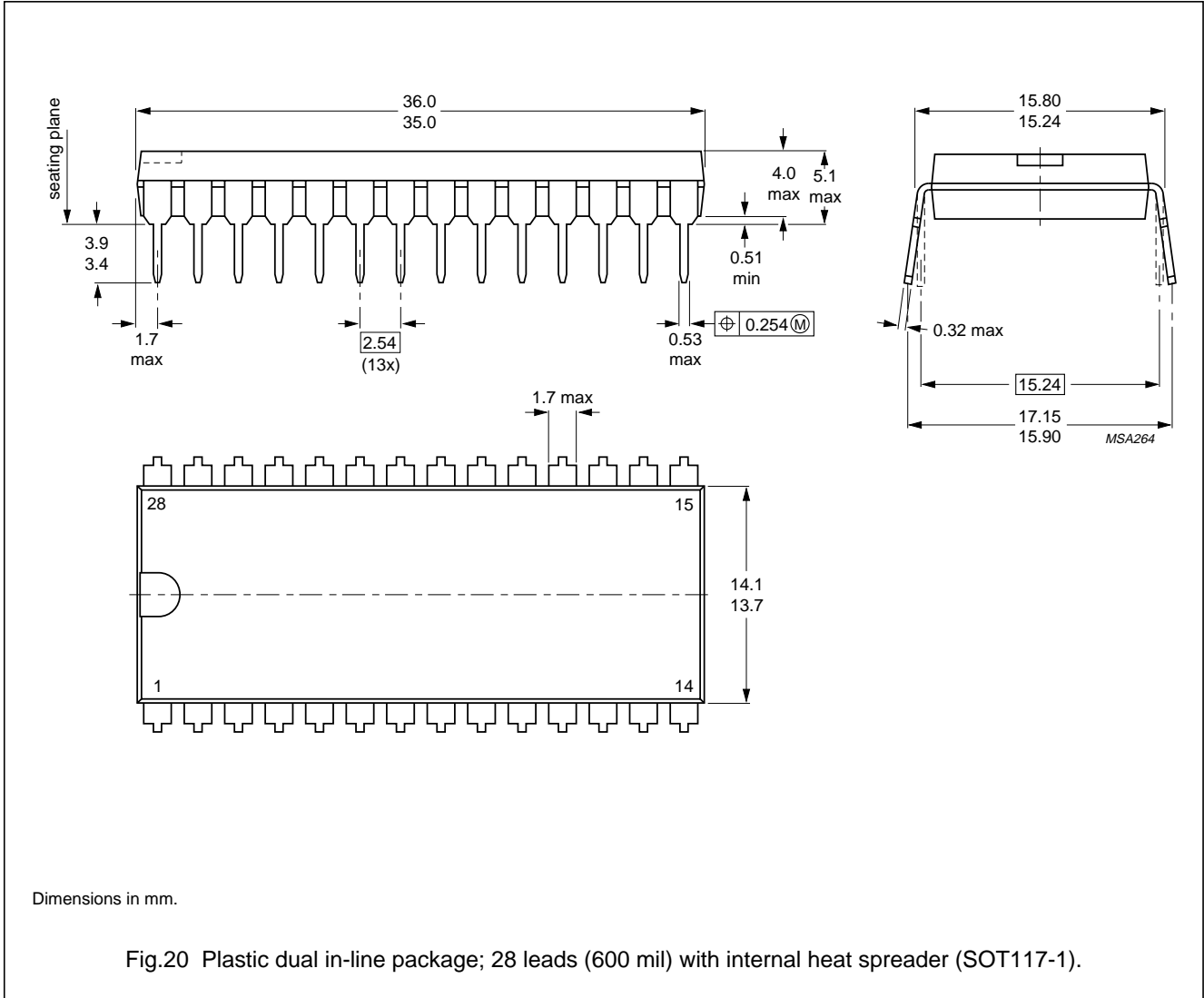

Video analog input interface

TDA8709A

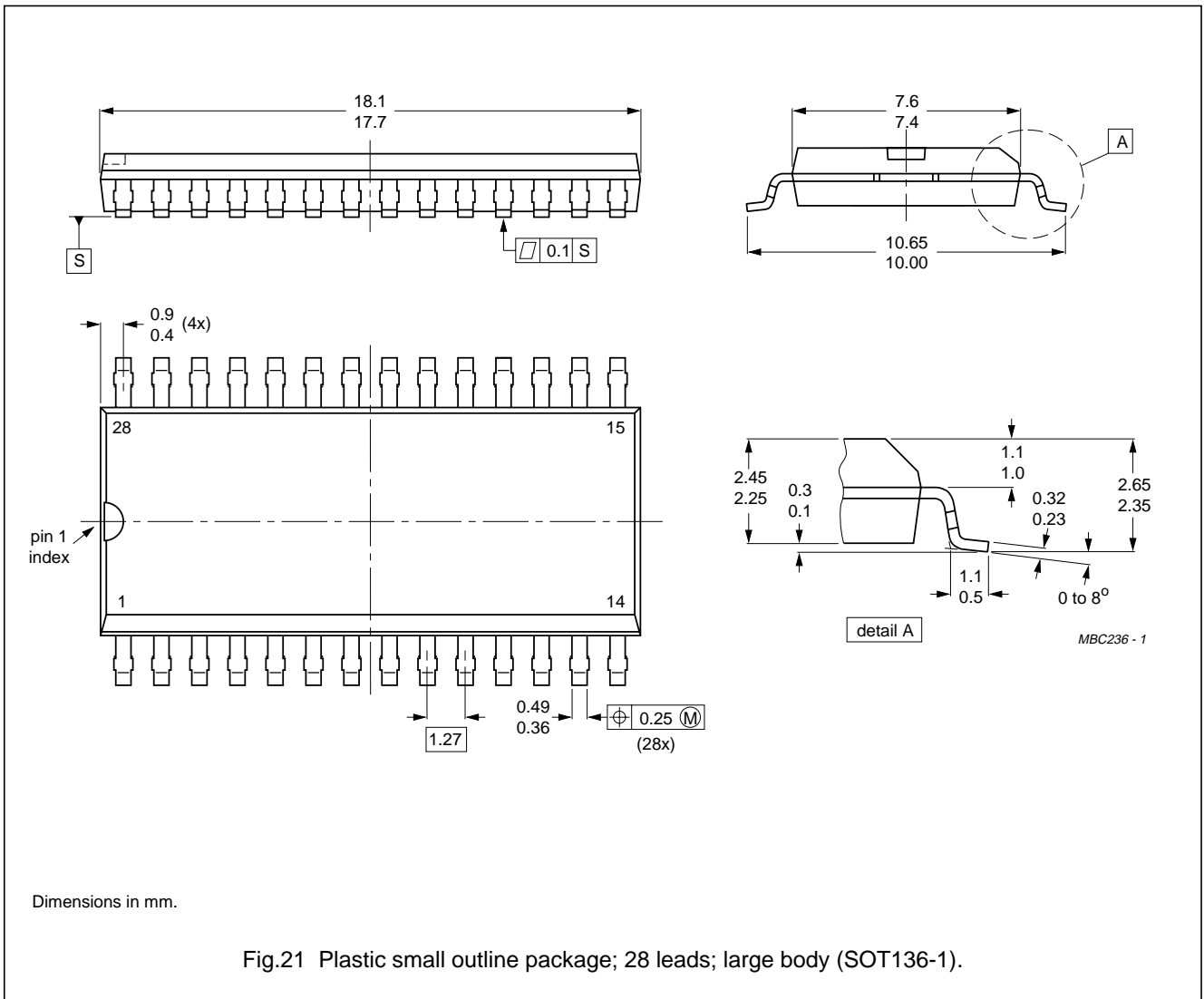

---

## Video analog input interface

## TDA8709A

---

### SOLDERING

#### Plastic dual in-line packages

BY DIP OR WAVE

The maximum permissible temperature of the solder is 260 °C; this temperature must not be in contact with the joint for more than 5 s. The total contact time of successive solder waves must not exceed 5 s.

The device may be mounted up to the seating plane, but the temperature of the plastic body must not exceed the specified storage maximum. If the printed-circuit board has been pre-heated, forced cooling may be necessary immediately after soldering to keep the temperature within the permissible limit.

REPAIRING SOLDERED JOINTS

Apply a low voltage soldering iron below the seating plane (or not more than 2 mm above it). If its temperature is below 300 °C, it must not be in contact for more than 10 s; if between 300 and 400 °C, for not more than 5 s.

#### Plastic small-outline packages

BY WAVE

During placement and before soldering, the component must be fixed with a droplet of adhesive. After curing the adhesive, the component can be soldered. The adhesive can be applied by screen printing, pin transfer or syringe dispensing.

Maximum permissible solder temperature is 260 °C, and maximum duration of package immersion in solder bath is 10 s, if allowed to cool to less than 150 °C within 6 s. Typical dwell time is 4 s at 250 °C.

A modified wave soldering technique is recommended using two solder waves (dual-wave), in which a turbulent wave with high upward pressure is followed by a smooth laminar wave. Using a mildly-activated flux eliminates the need for removal of corrosive residues in most applications.

BY SOLDER PASTE REFLOW

Reflow soldering requires the solder paste (a suspension of fine solder particles, flux and binding agent) to be applied to the substrate by screen printing, stencilling or pressure-syringe dispensing before device placement.

Several techniques exist for reflowing; for example, thermal conduction by heated belt, infrared, and vapour-phase reflow. Dwell times vary between 50 and 300 s according to method. Typical reflow temperatures range from 215 to 250 °C.

Preheating is necessary to dry the paste and evaporate the binding agent. Preheating duration: 45 min at 45 °C.

REPAIRING SOLDERED JOINTS (BY HAND-HELD SOLDERING IRON OR PULSE-HEATED SOLDER TOOL)

Fix the component by first soldering two, diagonally opposite, end pins. Apply the heating tool to the flat part of the pin only. Contact time must be limited to 10 s at up to 300 °C. When using proper tools, all other pins can be soldered in one operation within 2 to 5 s at between 270 and 320 °C. (Pulse-heated soldering is not recommended for SO packages.)

For pulse-heated solder tool (resistance) soldering of VSO packages, solder is applied to the substrate by dipping or by an extra thick tin/lead plating before package placement.

## Video analog input interface

TDA8709A

**DEFINITIONS**

<b>Data sheet status</b>	
Objective specification	This data sheet contains target or goal specifications for product development.
Preliminary specification	This data sheet contains preliminary data; supplementary data may be published later.
Product specification	This data sheet contains final product specifications.
<b>Limiting values</b>	
Limiting values given are in accordance with the Absolute Maximum Rating System (IEC 134). Stress above one or more of the limiting values may cause permanent damage to the device. These are stress ratings only and operation of the device at these or at any other conditions above those given in the Characteristics sections of the specification is not implied. Exposure to limiting values for extended periods may affect device reliability.	
<b>Application information</b>	
Where application information is given, it is advisory and does not form part of the specification.	

**LIFE SUPPORT APPLICATIONS**

These products are not designed for use in life support appliances, devices, or systems where malfunction of these products can reasonably be expected to result in personal injury. Philips customers using or selling these products for use in such applications do so at their own risk and agree to fully indemnify Philips for any damages resulting from such improper use or sale.



Video analog input interface

TDA8709A

---

**NOTES**

Video analog input interface

TDA8709A

---

**NOTES**

Video analog input interface

TDA8709A

---

**NOTES**

## Philips Semiconductors – a worldwide company

**Argentina:** IEROD, Av. Juramento 1992 - 14.b, (1428)  
BUENOS AIRES, Tel. (541)786 7633, Fax. (541)786 9367

**Australia:** 34 Waterloo Road, NORTH RYDE, NSW 2113,  
Tel. (02)805 4455, Fax. (02)805 4466

**Austria:** Triester Str. 64, A-1101 WIEN, P.O. Box 213,  
Tel. (01)60 101-1236, Fax. (01)60 101-1211

**Belgium:** Postbus 90050, 5600 PB EINDHOVEN, The Netherlands,  
Tel. (31)40 783 749, Fax. (31)40 788 399

**Brazil:** Rua do Rocio 220 - 5<sup>th</sup> floor, Suite 51,  
CEP: 04552-903-SÃO PAULO-SP, Brazil.  
P.O. Box 7383 (01064-970).

Tel. (011)821-2327, Fax. (011)829-1849

**Canada:** INTEGRATED CIRCUITS:

Tel. (800)234-7381, Fax. (708)296-8556  
DISCRETE SEMICONDUCTORS: 601 Milner Ave,  
SCARBOROUGH, ONTARIO, M1B 1M8,  
Tel. (416)292 5161 ext. 2336, Fax. (416)292 4477

**Chile:** Av. Santa Maria 0760, SANTIAGO,  
Tel. (02)773 816, Fax. (02)777 6730

**Colombia:** IPRELENZO LTDA, Carrera 21 No. 56-17,  
77621 BOGOTA, Tel. (571)249 7624/(571)217 4609,  
Fax. (571)217 4549

**Denmark:** Prags Boulevard 80, PB 1919, DK-2300 COPENHAGEN S,  
Tel. (032)88 2636, Fax. (031)57 1949

**Finland:** Sinikalliontie 3, FIN-02630 ESPOO,  
Tel. (9)0-50261, Fax. (9)0-520971

**France:** 4 Rue du Port-aux-Vins, BP317,  
92156 SURESNES Cedex,  
Tel. (01)4099 6161, Fax. (01)4099 6427

**Germany:** PHILIPS COMPONENTS UB der Philips G.m.b.H.,  
P.O. Box 10 63 23, 20043 HAMBURG,  
Tel. (040)3296-0, Fax. (040)3296 213.

**Greece:** No. 15, 25th March Street, GR 17778 TAVROS,  
Tel. (01)4894 339/4894 911, Fax. (01)4814 240

**Hong Kong:** PHILIPS HONG KONG Ltd., Components Div.,  
6/F Philips Ind. Bldg., 24-28 Kung Yip St., KWAI CHUNG, N.T.,  
Tel. (852)424 5121, Fax. (852)428 6729

**India:** Philips INDIA Ltd, Components Dept,  
Shivsagar Estate, A Block,  
Dr. Annie Besant Rd. Worli, Bombay 400 018  
Tel. (022)4938 541, Fax. (022)4938 722

**Indonesia:** Philips House, Jalan H.R. Rasuna Said Kav. 3-4,  
P.O. Box 4252, JAKARTA 12950,  
Tel. (021)5201 122, Fax. (021)5205 189

**Ireland:** Newstead, Clonskeagh, DUBLIN 14,  
Tel. (01)640 000, Fax. (01)640 200

**Italy:** PHILIPS COMPONENTS S.r.l.,  
Viale F. Testi, 327, 20162 MILANO,  
Tel. (02)6752.3302, Fax. (02)6752 3300.

**Japan:** Philips Bldg 13-37, Kohnan2-chome, Minato-ku, TOKYO 108,  
Tel. (03)3740 5028, Fax. (03)3740 0580

**Korea:** (Republic of) Philips House, 260-199 Itaewon-dong,  
Yongsan-ku, SEOUL, Tel. (02)794-5011, Fax. (02)798-8022

**Malaysia:** No. 76 Jalan Universiti, 46200 PETALING JAYA,  
SELANGOR, Tel. (03)750 5214, Fax. (03)757 4880

**Mexico:** Philips Components, 5900 Gateway East, Suite 200,  
EL PASO, TX 79905, Tel. 9-5(800)234-7381, Fax. (708)296-8556

**Netherlands:** Postbus 90050, 5600 PB EINDHOVEN, Bldg. VB  
Tel. (040)783749, Fax. (040)788399

**New Zealand:** 2 Wagener Place, C.P.O. Box 1041, AUCKLAND,  
Tel. (09)849-4160, Fax. (09)849-7811

**Norway:** Box 1, Manglerud 0612, OSLO,  
Tel. (022)74 8000, Fax. (022)74 8341

**Pakistan:** Philips Electrical Industries of Pakistan Ltd.,  
Exchange Bldg. ST-2/A, Block 9, KDA Scheme 5, Clifton,  
KARACHI 75600, Tel. (021)587 4641-49,  
Fax. (021)577035/5874546.

**Philippines:** PHILIPS SEMICONDUCTORS PHILIPPINES Inc.,  
106 Valero St. Salcedo Village, P.O. Box 2108 MCC, MAKATI,  
Metro MANILA, Tel. (02)810 0161, Fax. (02)817 3474

**Portugal:** PHILIPS PORTUGUESA, S.A.,  
Rua dr. António Loureiro Borges 5, Arquiparque - Miraflores,  
Apartado 300, 2795 LINDA-A-VELHA,  
Tel. (01)14163160/4163333, Fax. (01)14163174/4163366.

**Singapore:** Lorong 1, Toa Payoh, SINGAPORE 1231,  
Tel. (65)350 2000, Fax. (65)251 6500

**South Africa:** S.A. PHILIPS Pty Ltd., Components Division,  
195-215 Main Road Martindale, 2092 JOHANNESBURG,  
P.O. Box 7430 Johannesburg 2000,  
Tel. (011)470-5911, Fax. (011)470-5494.

**Spain:** Balmes 22, 08007 BARCELONA,  
Tel. (03)301 6312, Fax. (03)301 42 43

**Sweden:** Kottbygatan 7, Akalla. S-164 85 STOCKHOLM,  
Tel. (0)8-632 2000, Fax. (0)8-632 2745

**Switzerland:** Allmendstrasse 140, CH-8027 ZÜRICH,  
Tel. (01)488 2211, Fax. (01)481 77 30

**Taiwan:** PHILIPS TAIWAN Ltd., 23-30F, 66, Chung Hsiao West  
Road, Sec. 1. Taipei, Taiwan ROC, P.O. Box 22978,  
TAIPEI 100, Tel. (02)388 7666, Fax. (02)382 4382.

**Thailand:** PHILIPS ELECTRONICS (THAILAND) Ltd.,  
209/2 Sanpavuth-Bangna Road Prakanong,  
Bangkok 10260, THAILAND,  
Tel. (662)398-0141, Fax. (662)398-3319.

**Turkey:** Talatpasa Cad. No. 5, 80640 GÜLTEPE/ISTANBUL,  
Tel. (0 212)279 2770, Fax. (0212)269 3094

**United Kingdom:** Philips Semiconductors Limited, P.O. Box 65,  
Philips House, Torrington Place, LONDON, WC1E 7HD,  
Tel. (071)436 41 44, Fax. (071)323 03 42

**United States:** INTEGRATED CIRCUITS:  
811 East Arques Avenue, SUNNYVALE, CA 94088-3409,  
Tel. (800)234-7381, Fax. (708)296-8556  
DISCRETE SEMICONDUCTORS: 2001 West Blue Heron Blvd.,  
P.O. Box 10330, RIVIERA BEACH, FLORIDA 33404,  
Tel. (800)447-3762 and (407)881-3200, Fax. (407)881-3300

**Uruguay:** Coronel Mora 433, MONTEVIDEO,  
Tel. (02)70-4044, Fax. (02)92 0601

**For all other countries apply to:** Philips Semiconductors,  
International Marketing and Sales, Building BAF-1,  
P.O. Box 218, 5600 MD, EINDHOVEN, The Netherlands,  
Telex 35000 phtcnl, Fax. +31-40-724825

SCD31

© Philips Electronics N.V. 1994

All rights are reserved. Reproduction in whole or in part is prohibited without the prior written consent of the copyright owner.

The information presented in this document does not form part of any quotation or contract, is believed to be accurate and reliable and may be changed without notice. No liability will be accepted by the publisher for any consequence of its use. Publication thereof does not convey nor imply any license under patent- or other industrial or intellectual property rights.

Printed in The Netherlands

533061/1500/03/pp28

Document order number:

Date of release: June 1994

9397 734 60011

# Philips Semiconductors



# PHILIPS