

BLUETOOTH[®] BASEBAND

1 FEATURES

- Bluetooth[®] V1.1 specification compliant
- Point-to-point, point-to-multi-point (up to 7 slaves) and scatternet capability
- Asynchronous Connection-Less (ACL) link support giving data rates up to 721kbps
- Synchronous Connection-Oriented (SCO) link
- Standard BlueRF bus interface
- ARM7TDMI CPU
 - 32-bit Core
 - Run from 13MHz external clock
 - Support of 32 kHz crystal for low power mode
- Memory organization
 - 64KByte on-chip RAM
 - 4KByte on-chip boot ROM
 - Programmable external memory interface (EMI)
 - 8-bit or 16-bit external data bus
 - Up to 3 programmable chip-select signals
 - Hold-acknowledge bus arbitration support
- HW support for all packet types
 - ACL: DM1, 3, 5 and DH1, 3, 5
 - SCO: HV1, 2, 3 and DV1
- Communication interfaces
 - Serial Synchronous Interface
 - Two enhanced 16550 UART's with 128 byte fifo depth
 - 12Mbps USB interface
 - Fast master I2C bus interface
 - Multi slot PCM interface
 - 16 programmable GPIO
 - 2 external interrupts and various interrupt possibilities through other interfaces
- Ciphering support for up to 128-bit key
- Receiver Signal Strength Indication (RSSI) support for power-controlled links
- Separate control for external power amplifier (PA) for power class 1 support.
- Software support
 - Low level (up to HCI) stack or embedded stack with profiles
 - Support of UART and USB HCI transport layers
- Idle and power down modes
 - Ultra low power in idle mode
 - Low standby current



TFBGA132 (8x8x1.2mm)

ORDERING NUMBER: STLC2410B

Temperature range: -40 to +85 °C

- Extended temperature range
- Compliant to automotive specification AEC-Q100

1.1 Applications Features

Typical applications in which the STLC2410B can be used are:

- Portable computers, PDA
- Modems
- Handheld data transfer devices
- Cameras
- Computer peripherals
- Other type of devices that require the wireless communication provided by Bluetooth[®]
- Cable replacement

2 DESCRIPTION

The STLC2410B offers a compact and complete solution for short-range wireless connectivity. It incorporates all the lower layer functions of the Bluetooth[®] protocol.

The microcontroller allows the support of all data packets of Bluetooth[®] in addition to voice. The embedded controller can be used to run the Bluetooth[®] protocol and application layers if required. The software is located in an external memory accessed through the external memory interface.

3 QUICK REFERENCE DATA

3.1 Absolute Maximum Ratings

Operation of the device beyond these conditions is not guaranteed.
Sustained exposure to these limits will adversely affect device reliability

Table 1. Absolute Maximum Ratings

Symbol	Conditions	Min	Max	Unit
V _{DD}	Supply voltage core	V _{SS} - 0.5	2.5	V
V _{DDIO}	Supply voltage I/O		4	V
V _{IN}	input voltage on any digital pin	V _{SS} - 0.5	V _{DDIO} + 0.3	V
T _{amb}	Operating ambient temperature	-40	+85	°C
T _{stg}	Storage temperature	-65	+150	°C
T _{lead}	Lead temperature < 10s		+240	°C

3.2 Operating Ranges

Operating ranges define the limits for functional operation and parametric characteristics of the device.
Functionality outside these limits is not implied.

Table 2. Operating Ranges

Symbol	Conditions	Min	Typ	Max	Unit
V _{DD}	Supply voltage digital core and emi pads	1.55	1.8	1.95	V
V _{DDIO}	Supply voltage digital IO	2.7	3.3	3.6	V
T _{amb}	Operating ambient temperature	-40		+85	°C

3.3 I/O specifications

Depending on the interface, the I/O voltage is typical 1.8V (interface to the flash memory) or typical 3.3V (all the other interfaces). These I/Os comply to the EIA/JEDEC standard JESD8-B.

3.3.1 Specifications for 3.3V I/Os

Table 3. LVTTTL DC Input Specification (3V<V_{DDIO}<3.6V)

Symbol	Parameter	Conditions	Min	Typ	Max	Unit
V _{il}	Low level input voltage				0.8	V
V _{ih}	High level input voltage		2			V
V _{hyst}	Schmitt trigger hysteresis		0.4			V

Table 4. LVTTTL DC Output Specification (3V<V_{DDIO}<3.6V)

Symbol	Parameter	Conditions	Min	Typ	Max	Unit	Note
V _{ol}	Low level output voltage	I _{ol} = X mA			0.15	V	1
V _{oh}	High level output voltage	I _{oh} = -X mA	V _{DDIO} -0.15			V	1

Note 1 : X is the source/sink current under worst case conditions according to the drive capability. (See table 8, pad information for value of X).

3.3.2 Specifications for 1.8V I/Os

Table 5. DC Input Specification (1.55V < V_{DD} < 1.95V)

Symbol	Parameter	Conditions	Min	Typ	Max	Unit
V _{il}	Low level input voltage				0.35*V _{DD}	V
V _{ih}	High level input voltage		0.65*V _{DD}			V
V _{hyst}	Schmitt trigger hysteresis		0.2	0.3	0.5	V

Table 6. DC Output Specification (1.55V < V_{DD} < 1.95V)

Symbol	Parameter	Conditions	Min	Typ	Max	Unit	Note
V _{ol}	Low level output voltage	I _{ol} = X mA			0.15	V	1
V _{oh}	High level output voltage	I _{oh} = -X mA	V _{DD} -0.15			V	1

Note 1 : X is the source/sink current under worst case conditions according to the drive capability. (See table 8, pad information for value of X).

3.4 Current Consumption

Table 7. Typical power consumption of the STLC2410B and External Flash using UART (V_{DD} = V_{DD} Flash = PLLV_{DD} = 1.8V, V_{DDIO} = 3.3V)

STLC2410B State	Core		IO	Unit
	Slave	Master		
Standby (no low power mode)	5.10	5.10	0.13	mA
Standby (low power mode enabled)	0.94	0.94	0.13	mA
ACL connection (no transmission)	7.60	6.99	0.13	mA
ACL connection (data transmission)	7.90	7.20	0.13	mA
SCO connection (no codec connected)	8.70	7.90	0.14	mA
Inquiry and Page scan (low power mode enabled)	127	n.a.	5	μA
Low Power mode (32 kHz crystal)	20	20	0	μA

Figure 1. Block Diagram and Electrical Schematic

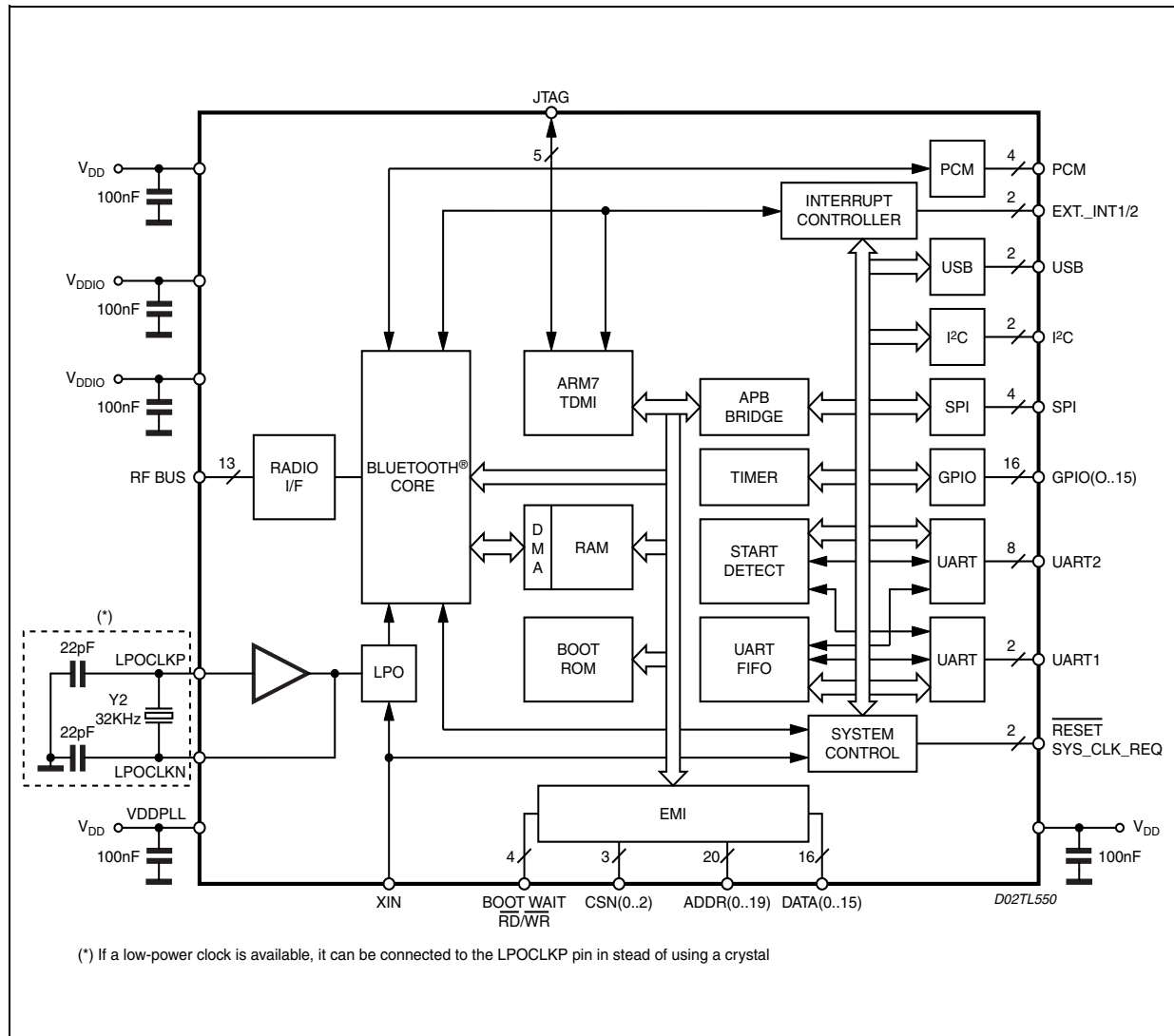

4 PINOUT

Figure 2. Pinout (Bottom view)

14	13	12	11	10	9	8	7	6	5	4	3	2	1	
gpio9	gpio11	gpio14	vddio	brxd	bmosi	bdclk	bpaen	brxen	ant_sw	tdi	ntrst	test	xin	A
n.c.	gpio10	gpio13	n.c.	brclk	bnden	btxd	vdd	btxen	vddio	tdo	tck	nreset	sys_clk_req	B
gpio8	vddpll	gpio12	gpio15	vssio	bmiso	bsen	vss	bpktctl	vssio	tms	uart1_rxd	uart1_txd	i2c_dat	C
vsspll	gpio6	gpio7									i2c_clk	int1	int2	D
gpio3	gpio4	gpio5									vddio	vssio	pcm_sync	E
gpio0	gpio1	gpio2									pcm_clk	pcm_a	pcm_b	F
boot	lpo_clk_p	lpo_clk_n									uart2_rxd	usb_dp	usb_dn	G
data14	data15	wait									uart2_i2	uart2_i1	uart2_txd	H
data13	data12	data11									uart2_io1	uart2_o2	uart2_o1	J
data10	data9	vss									vss	vdd	uart2_io2	K
vdd	vss	vdd									spi_frm	vssio	vddio	L
data8	data7	data6	data0	addr17	vss	addr13	addr10	addr5	addr2	vdd	csn1	spi_txd	spi_clk	M
data5	data4	data2	addr19	addr16	vdd	addr12	addr9	addr6	addr3	vss	csn2	wrn	spi_rxd	N
data3	n.c.	data1	addr18	addr15	addr14	addr11	addr8	addr7	addr4	addr1	addr0	csn0	rdn	P

D02TL551

4.1 Pin Description and Assignment

Table4 : STLC2410B pinlist shows the pinout of STLC2410B; there are 107 digital functional pins and 22 supply pins. The column "PU/PD" shows the pads implementing an internal weak pull-up/down, to fix value if the pin is left open. This can not replace an external pull-up/down.

The pads are grouped according to two different power supply values, as shown in column "VDD":

- V1 for 3.3 V typical 2.7 - 3.6 V range
- V2 for 1.8 V typical 1.55 - 1.95 V range

Finally the column "DIR" describes the pin directions:

- I for inputs
- O for outputs
- I/O for input/outputs
- O/t for tristate outputs

Table 8. Pin List

Name	Pin #	Description	DIR	PU/PD	VDD	PAD
Interface to external memory						
int1	D2	External Interrupt used also as external wakeup	I	(1)	V1	CMOS, 3.3V TTL compatible schmitt trigger
int2	D1	Second external interrupt	I	(1)		
boot	G14	Select external boot from EMI or internal from ROM	I	(1)	V2	CMOS 1.8V
wait	H12	EMI external wait signal (left open)	I	PD		
rdn	P1	External read	O		V2	CMOS 1.8V 4mA slew rate control
wrn	N2	External write	O			
csn0	P2	External chip select bank 0	O			
csn1	M3	External chip select bank 1	O			
csn2	N3	External chip select bank 2	O			
addr0	P3	External address bit 0	O			
addr1	P4	External address bit 1	O			
addr2	M5	External address bit 2	O			
addr3	N5	External address bit 3	O			
addr4	P5	External address bit 4	O			
addr5	M6	External address bit 5	O			
addr6	N6	External address bit 6	O			
addr7	P6	External address bit 7	O			
addr8	P7	External address bit 8	O			
addr9	N7	External address bit 9	O			
addr10	M7	External address bit 10	O			
addr11	P8	External address bit 11	O			
addr12	N8	External address bit 12	O			
addr13	M8	External address bit 13	O			
addr14	P9	External address bit 14	O			
addr15	P10	External address bit 15	O			
addr16	N10	External address bit 16	O			
addr17	M10	External address bit 17	O			
addr18	P11	External address bit 18	O			
addr19	N11	External address bit 19	O			
data0	M11	External data bit 0	I/O	PD	V2	CMOS 1.8V 4mA slew rate control
data1	P12	External data bit 1	I/O	PD		
data2	N12	External data bit 2	I/O	PD		
data3	P14	External data bit 3	I/O	PD		
data4	N13	External data bit 4	I/O	PD		
data5	N14	External data bit 5	I/O	PD		

Table 8. Pin List (continued)

Name	Pin #	Description	DIR	PU/PD	VDD	PAD
data6	M12	External data bit 6	I/O	PD	V2	CMOS 1.8V 4mA slew rate control
data7	M13	External data bit 7	I/O	PD		
data8	M14	External data bit 8	I/O	PD		
data9	K13	External data bit 9	I/O	PD		
data10	K14	External data bit 10	I/O	PD		
data11	J12	External data bit 11	I/O	PD		
data12	J13	External data bit 12	I/O	PD		
data13	J14	External data bit 13	I/O	PD		
data14	H14	External data bit 14	I/O	PD		
data15	H13	External data bit 15	I/O	PD		
SPI interface						
spi_frm	L3	Synchronous Serial Interface frame sync	I/O		V1	CMOS, 3.3V TTL compatible, 2mA tristate slew rate control schmitt trigger
spi_clk	M1	Synchronous Serial Interface clock	I/O			
spi_txd	M2	Synchronous Serial Interface transmit data	O/t		V1	CMOS, 3.3V TTL compatible, 2mA slew rate control
spi_rxd	N1	Synchronous Serial Interface receive data	I	(1)	V1	CMOS, 3.3V TTL compatible schmitt trigger
UART interface						
uart1_txd	C2	Uart1 transmit data	O/t		V1	CMOS, 3.3V TTL compatible, 2mA slew rate control
uart1_rxd	C3	Uart1 receive data	I	(2)	V1	CMOS, 3.3V TTL compatible schmitt trigger
uart2_o1	J1	Uart2 modem output	O		V1	CMOS, 3.3V TTL compatible, 2mA slew rate control
uart2_o2	J2	Uart2 modem output	O/t		V1	CMOS, 3.3V TTL compatible, 2mA slew rate control
uart2_i1	H2	Uart2 modem input	I	(2)	V1	CMOS, 3.3V TTL compatible
uart2_i2	H3	Uart2 modem input	I	(2)	V1	
uart2_io1	J3	Uart2 modem input/output	I/O	(2)	V1	CMOS, 3.3V TTL compatible, 2mA tristate slew rate control
uart2_io2	K1	Uart2 modem input/output	I/O	(2)	V1	
uart2_txd	H1	Uart2 transmit data	O/t		V1	CMOS, 3.3V TTL compatible, 2mA slew rate control

Table 8. Pin List (continued)

Name	Pin #	Description	DIR	PU/PD	VDD	PAD
uart2_rxd	G3	Uart2 receive data	I	(2)	V1	CMOS, 3.3V TTL compatible
I2C interface						
i2c_dat	C1	I2C data pin	I/O	(3)	V1	CMOS, 3.3V TTL compatible, 2mA tristate slew rate control
i2c_clk	D3	I2C clock pin	I/O	(3)	V1	
USB interface						
usb_dn	G1	USB - pin	I/O	(1)	V1	
usb_dp	G2	USB + pin	I/O	(1)	V1	
GPIO interface						
gpio0	F14	Gpio port 0	I/O	PU	V1	CMOS, 3.3V TTL compatible, 4mA tristate slew rate control
gpio1	F13	Gpio port 1	I/O	PU		
gpio2	F12	Gpio port 2	I/O	PU		
gpio3	E14	Gpio port 3	I/O	PU	V1	CMOS, 3.3V TTL compatible, 4mA tristate slew rate control schmitt trigger
gpio4	E13	Gpio port 4	I/O	PU	V1	CMOS, 3.3V TTL compatible, 4mA tristate slew rate control
gpio5	E12	Gpio port 5	I/O	PU		
gpio6	D13	Gpio port 6	I/O	PU		
gpio7	D12	Gpio port 7	I/O	PU		
gpio8	C14	Gpio port 8	I/O	PU	V1	CMOS, 3.3V TTL compatible, 2mA tristate slew rate control
gpio9	A14	Gpio port 9	I/O	PU		
gpio10	B13	Gpio port 10	I/O	PU		
gpio11	A13	Gpio port 11	I/O	PU		
gpio12	C12	Gpio port 12	I/O	PU		
gpio13	B12	Gpio port 13	I/O	PU	V1	CMOS, 3.3V TTL compatible, 2mA tristate slew rate control
gpio14	A12	Gpio port 14	I/O	PU		
gpio15	C11	Gpio port 15	I/O	PU		
Clock and test pins						
xin	A1	System clock	I		V1	CMOS, 3.3V TTL compatible schmitt trigger
nreset	B2	Reset	I			
sys_clk_req	B1	System clock request	I/O		V1	CMOS, 3.3V TTL compatible, 2mA tristate slew rate control
lpo_clk_p	G13	Low power oscillator + / Slow clock input	I	(1)	V2	
lpo_clk_n	G12	Low power oscillator -	O			
test	A2	Test mode	I	PD	V1	CMOS, 3.3V TTL compatible

Table 8. Pin List (continued)

Name	Pin #	Description	DIR	PU/PD	VDD	PAD
JTAG interface						
ntrst	A3	JTAG pin	I	PD	V1	CMOS, 3.3V TTL compatible
tck	B3	JTAG pin	I	(1)	V1	CMOS, 3.3V TTL compatible schmitt trigger
tms	C4	JTAG pin	I	PU	V1	CMOS, 3.3V TTL compatible
tdi	A4	JTAG pin	I	PU		
tdo	B4	JTAG pin (should be left open)	O/t		V1	CMOS, 3.3V TTL compatible, 2mA slew rate control
PCM interface						
pcm_a	F2	PCM data	I/O	PD	V1	CMOS, 3.3V TTL compatible, 2mA tristate slew rate control
pcm_b	F1	PCM data	I/O	PD		
pcm_sync	E1	PCM 8kHz sync	I/O	PD		
pcm_clk	F3	PCM clock	I/O	PD	V1	CMOS, 3.3V TTL compatible, 2mA tristate slew rate control schmitt trigger
Radio interface						
brclk	B10	Transmit clock	I	(1)	V1	CMOS, 3.3V TTL compatible schmitt trigger
brxd	A10	Receive data	I			
bmiso	C9	RF serial interface input data	I	(1)	V1	CMOS, 3.3V TTL compatible
bnden	B9	RF serial interface control	O		V1	CMOS, 3.3V TTL compatible, 2mA slew rate control
bmosi	A9	RF serial interface output data	O			
bdclk	A8	RF serial interface clock	O			
btxd	B8	Transmit data	O			
bsen	C8	Synthesizer ON	O			
bpaen	A7	Open PLL	O			
brxen	A6	Receive ON	O			
btxen	B6	Transmit ON	O			
bpktctl	C6	Packet ON	O			
ant_sw	A5	Antenna switch	O		V1	CMOS, 3.3V TTL compatible, 8mA slew rate control

(1) Should be strapped to vssio if not used

(2) Should be strapped to vddio if not used

(3) Should have a 10 kOhm pull-up if not used.

Table 4. Pin List (continued)

Name	Pin #	Description
Power Supply		
vsspll	D14	PLL ground
vddpll	C13	1.8V supply for PLL
vdd	B7	1.8V Digital supply
vdd	K2	1.8V Digital supply
vdd	L12	1.8V Digital supply
vdd	L14	1.8V Digital supply
vdd	M4	1.8V Digital supply
vdd	N9	1.8V Digital supply
vddio	A11	3.3V I/O's supply
vddio	B5	3.3V I/O's supply
vddio	E3	3.3V I/O's supply
vddio	L1	3.3V I/O's supply
vss	C7	Digital ground
vss	K3	Digital ground
vss	K12	Digital ground
vss	L13	Digital ground
vss	M9	Digital ground
vss	N4	Digital ground
vssio	C5	I/O's ground
vssio	C10	I/O's ground
vssio	E2	I/O's ground
vssio	L2	I/O's ground

5 FUNCTIONAL DESCRIPTION

5.1 Baseband

5.1.1 Overview

The baseband is fully compliant with the Bluetooth® specification 1.1, including:

- 7 slaves support.
- Asynchronous Connection-Less (ACL) link support giving data rates up to 721kb per second.
- Synchronous Connection-Oriented (SCO) link with support for 1 voice channel over the air interface.
- HW support for all packet types:
 - ACL: DM1, 3, 5 and DH1, 3, 5.
 - SCO: HV1, 2, 3, and DV1.
- Support for three PCM channels in the PCM interface.
- Architecture gives ultra-low power consumption.
- Ciphering support for up to 128-bit, configurable by software.
- Receiver Signal Strength Indication (RSSI) support for power-controlled links.
- Flexible voice formats to Host and over air (CVSD, PCM 16/8-bit, A-law, μ -law).
- High quality filtering of voice packets enabling excellent audio quality.
- Point-to-multipoint support.
- Scatternet support, communication between two simultaneously running piconets.
- Full Bluetooth® software stack available.
- Low level link controller.
- Specific external power amplifier (PA) control for class1 support.
- Extended wake-up and interrupt functionality for HID support.

5.1.2 Processor and memory

- ARM7TDMI.
- 64Kbyte of static RAM.
- 4Kbyte of metal programmable ROM
- Extension of the ARM Bus to handle external program FLASH or RAM or dedicated peripherals.
- Data bus in byte or half word format (8-bit or 16-bit).
- Address bus 20-bit wide to support 1 Mbyte within each bank.
- Direct Support for 3 external devices.
- Access to slow peripherals.

6 GENERAL SPECIFICATION

6.1 SYSTEM CLOCK

The STLC2410B works with a single clock provided on the XIN pin. The value of this external clock should be 13MHz \pm 20ppm (overall).

6.1.1 SLOW CLOCK

The slow clock is used by the baseband as reference clock during the low power modes. Compared to the 13MHz clock, the slow clock only requires an accuracy of \pm 250ppm (overall).

Several options are foreseen in order to adjust the STLC2410B behaviour according to the features of the radio used:

- if the system clock (e.g. 13MHz) is not provided at all times (power consumption saving) and no slow clock is provided by the system, a 32 kHz crystal must be used by the STLC2410B (default mode).
- if the system clock (e.g. 13MHz) is not provided at all times (power consumption saving) and the system provides a slow clock at 32kHz or 3.2kHz, this signal is simply connected to the STLC2410B (lpo_clk_p).
- if the system clock (e.g. 13MHz) is provided at all times, the STLC2410B generates from the 13MHz reference clock an internal 32kHz clock. This mode is not an optimized mode for power consumption.

6.2 BOOT PROCEDURE

The boot code instructions are the first that ARM7TDMI executes after an HW reset. All the internal device's registers are set to their default value.

There are 2 types of boot:

- external flash boot.

When boot pin is set to `1` (connected to VDD), the STLC2410B boots on its external memory which is normally a flash memory.

- UART download boot from ROM.

When boot pin is set to `0` (connected to GND), the STLC2410B boots on its internal ROM (needed to download the new firmware).

When booting on the internal ROM, the STLC2410B will monitor the UART interface for approximately 1.4 second. If there is no request for code downloading during this period, the ROM jumps to external flash.

6.3 CLOCK DETECTION

The STLC2410B has a automatic slow clock frequency detection (32kHz, 3.2kHz or none).

6.4 MASTER RESET

When the device's reset is held active (NRESET is low), all two uart txd pins (UART1_TXD and UART2_TXD) are driven low. When the NRESET returns high, the device starts to boot.

Remark: The device should be held in active reset for minimum 20ms in order to guarantee a complete reset of the device.

6.5 INTERRUPTS/WAKE-UP

The external pins int1 and int2, and up to 8 GPIOs can be used both as external interrupt source and as wake-up source. In addition the chip can be woken-up by USB or Uart Rx.

7 INTERFACES

7.1 UART Interface

The chip contains two enhanced (128-byte FIFO depth, sleep mode, 127 Rx and 128 Tx interrupt thresholds) UARTs named UART1 and UART2 compatible with the standard M16550 UART.

For UART1, only Rx and Tx signals are available (mainly used for debug purposes and in test mode).

UART2 features:

- standard HCI UART transport layer:
 - all HCI commands as described in the Bluetooth® specification 1.1
 - ST specific HCI command (check STLC2410B Software Interface document for more information)
- RXD, TXD, CTS, RTS on permanent external pins
- 128-byte FIFOs, for transmit and for receive
- Default configuration: 57.6 kbits/s
- Specific HCI command to change to the following baud rates:

Table 9. List of supported baud rates

Baud rate		
–	57.6 k (default)	4800
921.6k	38.4 k	2400
460.8 k	28.8 k	1800
230.4 k	19.2 k	1200
153.6 k	14.4 k	900
115.2 k	9600	600
76.8 k	7200	300

7.2 Synchronous Serial Interface

The Synchronous Serial Interface is a flexible module that supports full-duplex and half-duplex synchronous communications with external devices in Master and Slave mode. It allows the STLC2410B to communicate with peripheral devices.

The Synchronous Serial Interface is also capable of inter processor communications in a multiple-master system. This interface is flexible enough to interface directly with numerous standard product peripherals. This Synchronous Serial Interface peripheral features:

- full duplex, four-wire synchronous transfers.
- Microwire half duplex transfer using 8-bit control message
- programmable clock polarity and phase.
- transmit data pin tri state able when not transmitting
- Master or Slave operation
- Programmable clock bit rate up to XIN/4
- Programmable data frame from 4 bits to 16 bits.
- Independent transmit and receive 16 words FIFO.
- Internal loopback

7.3 I2C Interface

The I2C port is used both to connect to an external E2PROM and to access I2C peripherals like the STw5094 Codec. The I2C implemented in the STLC2410B is a master I2C, it has the full control of the I2C bus at all time. I2C slave functionality is not supported, so any other I2C attached to the I2C bus must be slave, otherwise bus contention will occur.

Figure 3. I2C BUS master flow diagram

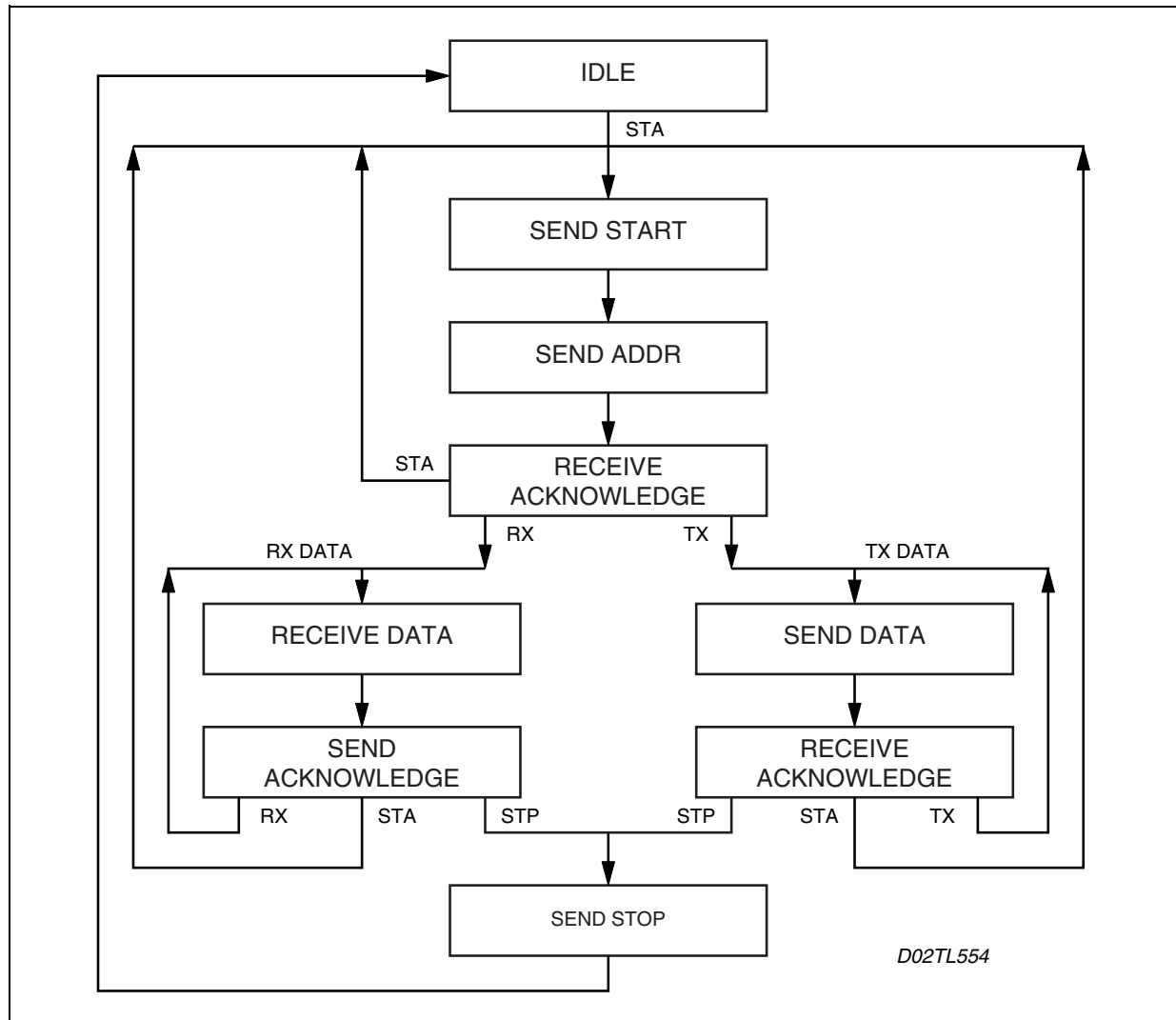

7.4 USB Interface

The USB interface is compliant with the USB 2.0 full speed specification. Max throughput on the USB interface is 12 Mbit/s.

Figure 4 gives an overview of the main components needed for supporting the USB interface, as specified in the Bluetooth® Core Specification (Part H:2). For clarity, the serial interface (including the UART Transport Layer) is also shown.

Figure 4. USB Interface

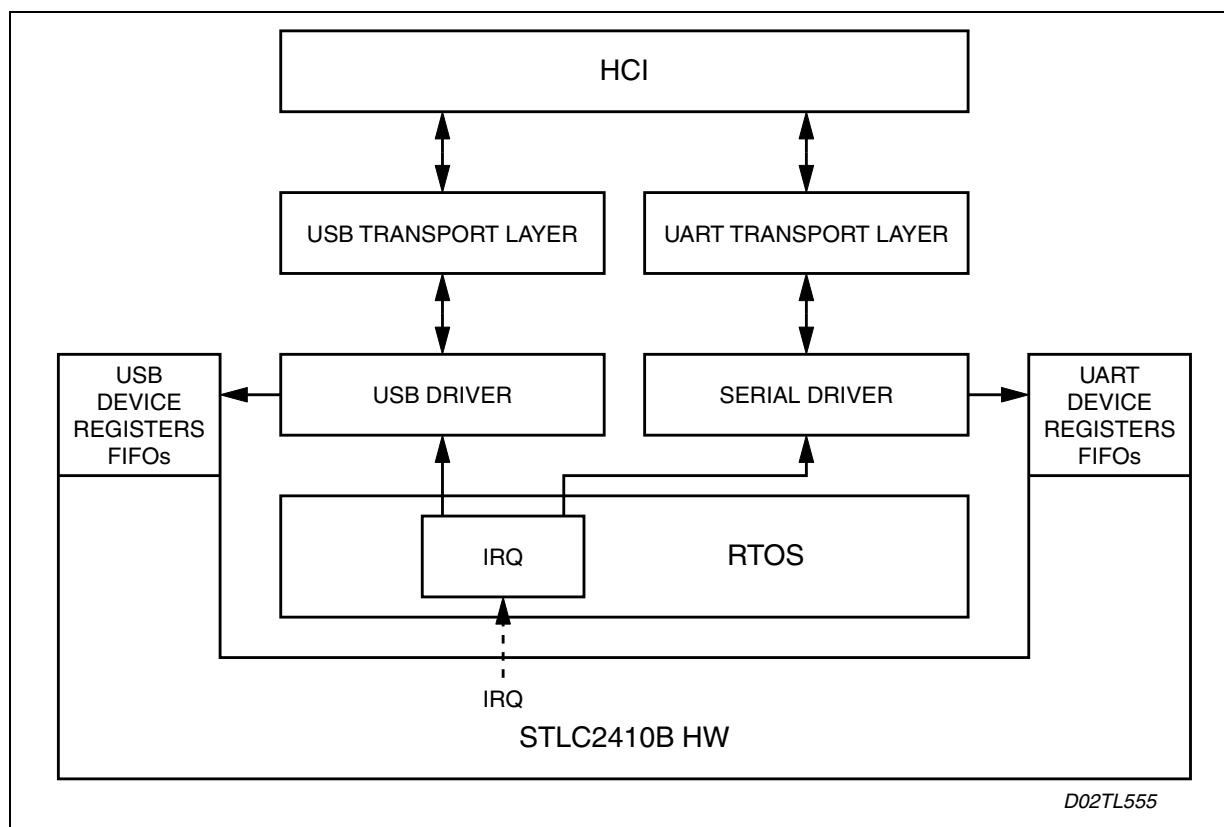

The USB device registers and FIFOs are memory mapped. The USB Driver will use these registers to access the USB interface. The equivalent exists for the HCI communication over UART.

For transmission to the host, the USB & Serial Drivers interface with the HW via a set of registers and FIFOs, while in the other direction, the hardware may trigger the Drivers through a set of interrupts (identified by the RTOS, and directed to the appropriate Driver routines).

7.5 JTAG Interface

The JTAG interface is compliant with the JTAG IEEE Std 1149.1. It allows both the boundary scan of the digital pins and the debug of the ARM7TDMI application when connected with the standard ARM7 development tools.

7.6 RF Interface

The STLC2410B radio interface is compatible to BlueRF (unidirectional RxMode2 for data and unidirectional serial interface for control).

7.7 PCM voice interface

The voice interface is a direct PCM interface to connect to a standard CODEC (e.g. STw5093 or STw5094) including internal decimator and interpolator filters. The data can be linear PCM (13-16bit), μ -Law (8bit) or A-Law (8bit). By default the codec interface is configured as master. The encoding on the air interface is programmable to be CVSD, A-Law or μ -Law.

The PCM block is able to manage the PCM bus with up to 3 timeslots.

PCM clock and data are in master mode available at 2 MHz or at 2.048 MHz to allow interfacing of standard codecs.

The four signals of the PCM interface are:

- PCM_CLK : PCM clock
- PCM_SYNC : PCM 8kHz sync
- PCM_A : PCM data
- PCM_B : PCM data

Directions of PCM_A and PCM_B are software configurable.

Figure 5. PCM (A-law, μ -law) standard mode

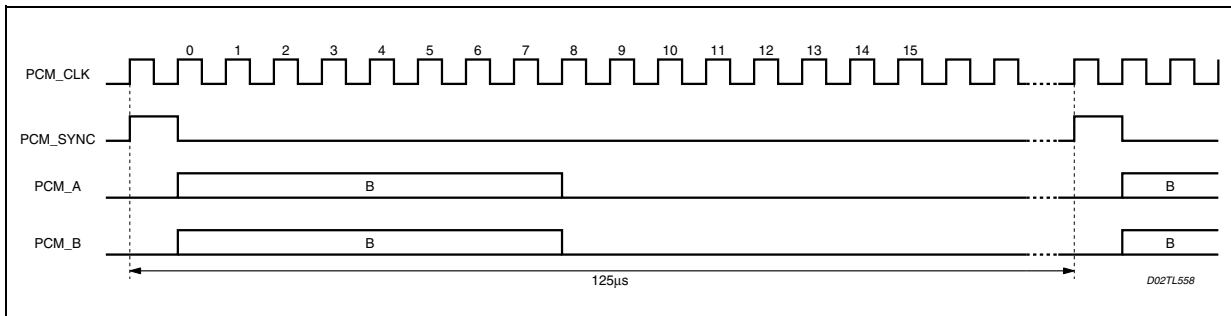

Figure 6. Linear mode

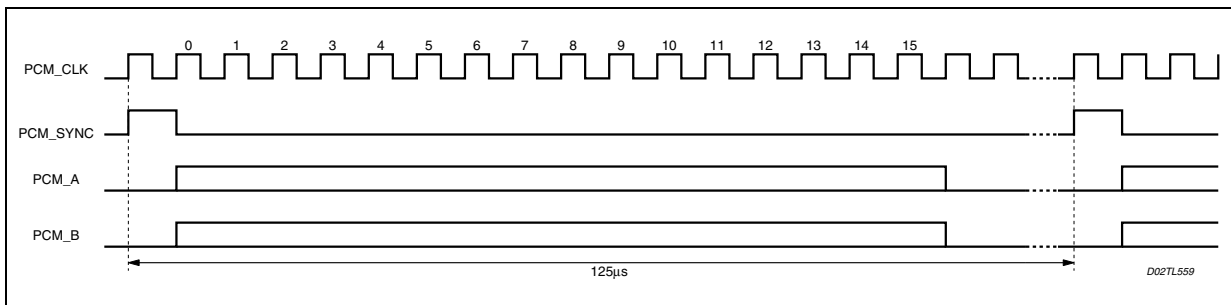
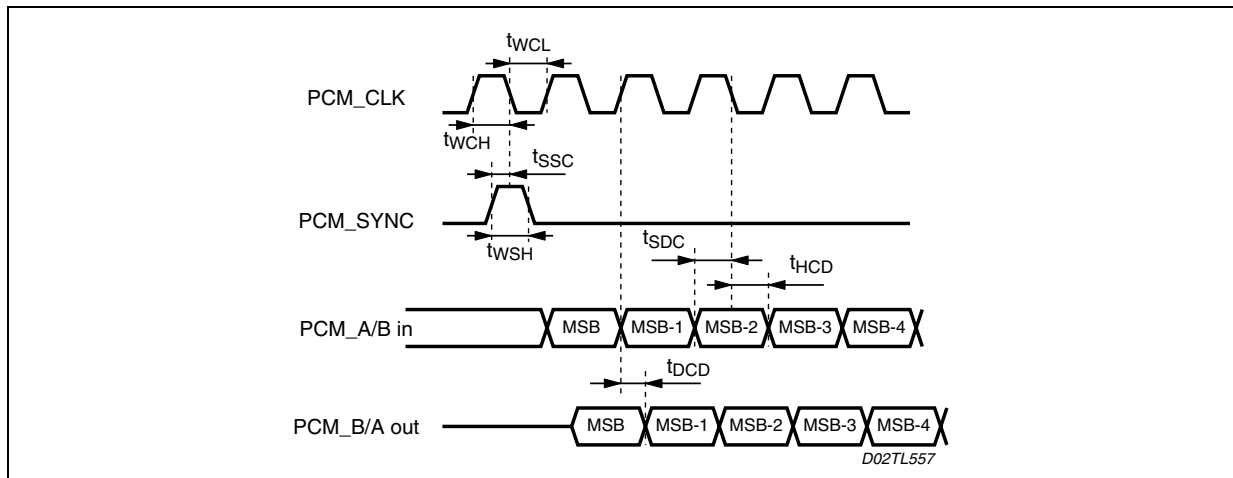

Table 10. PCM interface timing.

Symbol	Description	Min	Typ	Max	Unit
PCM Interface					
F _{pcm_clk}	Frequency of PCM_CLK (master)	-	2048		kHz
F _{pcm_sync}	Frequency of PCM_SYNC		8		kHz
t _{wCH}	High period of PCM_CLK	200			ns
t _{wCL}	Low period of PCM_CLK	200			ns
t _{wSH}	High period of PCM_SYNC	200			ns
t _{sSC}	Setup time, PCM_SYNC high to PCM_CLK low	100			ns
t _{sDC}	Setup time, PCM_A/B input valid to PCM_CLK low	100			ns
t _{hCD}	Hold time, PCM_CLK low to PCM_A/B input invalid	100			ns
t _{dCD}	Delay time, PCM_CLK high to PCM_A/B output valid			150	ns

Figure 7. PCM interface timing



8 HCI UART TRANSPORT LAYER

The UART Transport Layer is specified by the Bluetooth® SIG (Part H:4), and allows HCI level communication between a host controller (STLC2410B) and a host (e.g. PC), via a RS232 interface.

The objective of this HCI UART Transport Layer is to make it possible to use the Bluetooth® HCI over a serial interface between two UARTs on the same PCB. The HCI UART Transport Layer assumes that the UART communication is free from line errors.

8.1 UART Settings

The HCI UART Transport Layer uses the following settings:

- Baud rate: Configurable (Default baud rate: 57.6 kbits/s)
- Number of data bits: 8
- Parity bit: no parity
- Stop bit: 1 stop bit
- Flow control: RTS/CTS
- Flow-off response time: 3 ms

Flow control with RTS/CTS is used to prevent temporary UART buffer overrun. It should not be used for flow control of HCI, since HCI has its own flow control mechanisms for HCI commands, HCI events and HCI data.

If CTS is 1, then the Host/Host Controller is allowed to send.

If CTS is 0, then the Host/Host Controller is not allowed to send.

The flow-off response time defines the maximum time from setting RTS to 0 until the byte flow actually stops. The signals should be connected in a null-modem fashion; i.e. the local TXD should be connected to the remote RXD and the local RTS should be connected to the remote CTS and vice versa.

Figure 8. UART Transport Layer

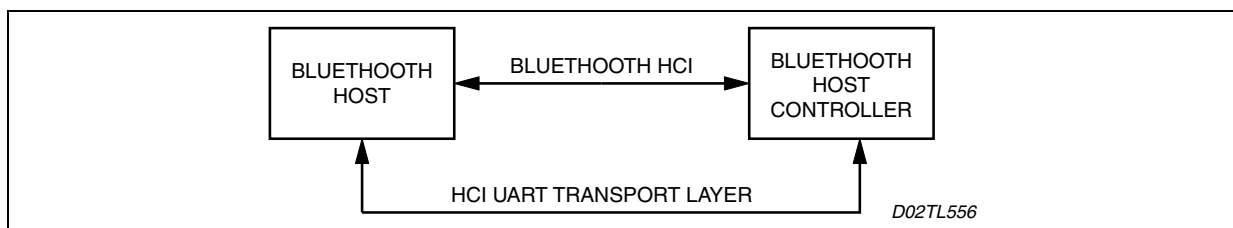

9 HCI USB TRANSPORT LAYER

The USB Transport Layer has been specified by the Bluetooth® SIG (Part H:2), and allows HCI level communication between a host controller (STLC2410B) and a host (e.g. PC), via a USB interface. The USB Transport Layer is completely implemented in SW. It accepts HCI messages from the HCI Layer, prepares it for transmission over a USB bus, and sends it to the USB Driver. It reassembles the HCI messages from USB data received from the USB Driver, and sends these messages to the HCI Layer. The Transport Layer does not interpret the contents (payload) of the HCI messages; it only examines the header.

10 POWER CLASS1 SUPPORT

The chip can control an external power amplifier (PA). Several signals are duplicated on GPIOs for this purpose in order to avoid digital/analog noise loops in the radio.

The Class1_En register enables the alternate functions of GPIO[15:6] to generate the signals for driving an external PA in a Bluetooth® power class1 application.

Every bit enables a dedicated signal on a GPIO pin, as described in Table 11 : Power Class 1 functionality.

Table 11. Power Class 1 functionality

Class1_En bit	involved GPIO	description (when class1_En bit = '1')
rxon	gpio[6]	outputs a copy of rx_on pin to switch LNA/RF switch on/off
not rxon	gpio[7]	outputs an inverted copy of rx_on pin to switch LNA/RF switch on/off
PA0	gpio[8]	Bit 0 of the PA value for the current connection
PA1	gpio[9]	Bit 1 of the PA value for the current connection
PA2	gpio[10]	Bit 2 of the PA value for the current connection
PA3	gpio[11]	Bit 3 of the PA value for the current connection
PA4	gpio[12]	Bit 4 of the PA value for the current connection
PA5	gpio[13]	Bit 5 of the PA value for the current connection
PA6	gpio[14]	Bit 6 of the PA value for the current connection
PA7	gpio[15]	Bit 7 of the PA value for the current connection

rx_on is the same as the rx_on output pin. Not rx_on is the inverted signal, in order to save components on the application board.

PA7 to PA0 are the power amplifier control lines. They are managed, on a connection basis, by the base-band core. The Power Level programmed for a certain Bluetooth® connection is managed by the firmware, as specified in the Bluetooth® SIG spec.

DIM.	mm			inch		
	MIN.	TYP.	MAX.	MIN.	TYP.	MAX.
A	1.010		1.200	0.040		0.047
A1	0.150			0.006		
A2		0.820			0.032	
b	0.250	0.300	0.350	0.010	0.012	0.014
D	7.850	8.000	8.150	0.310	0.315	0.321
D1		6.500			0.256	
E	7.850	8.000	8.150	0.310	0.315	0.321
E1		6.500			0.256	
e	0.450	0.500	0.550	0.018	0.020	0.022
f	0.600	0.750	0.900	0.024	0.029	0.035
ddd			0.080			0.003

OUTLINE AND MECHANICAL DATA

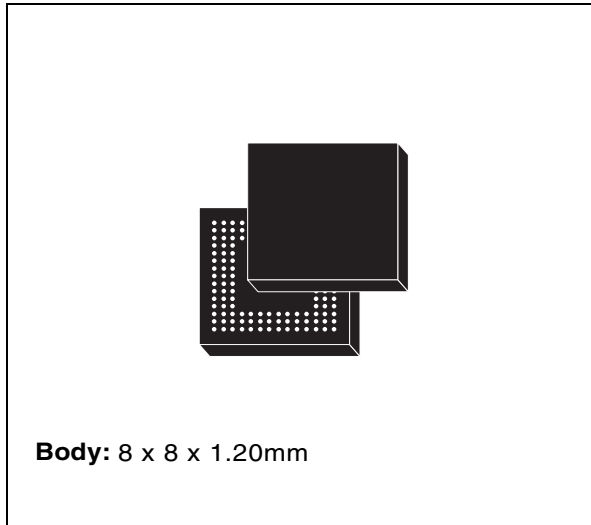

**TFBGA132
Fine Pitch Ball Grid Array**

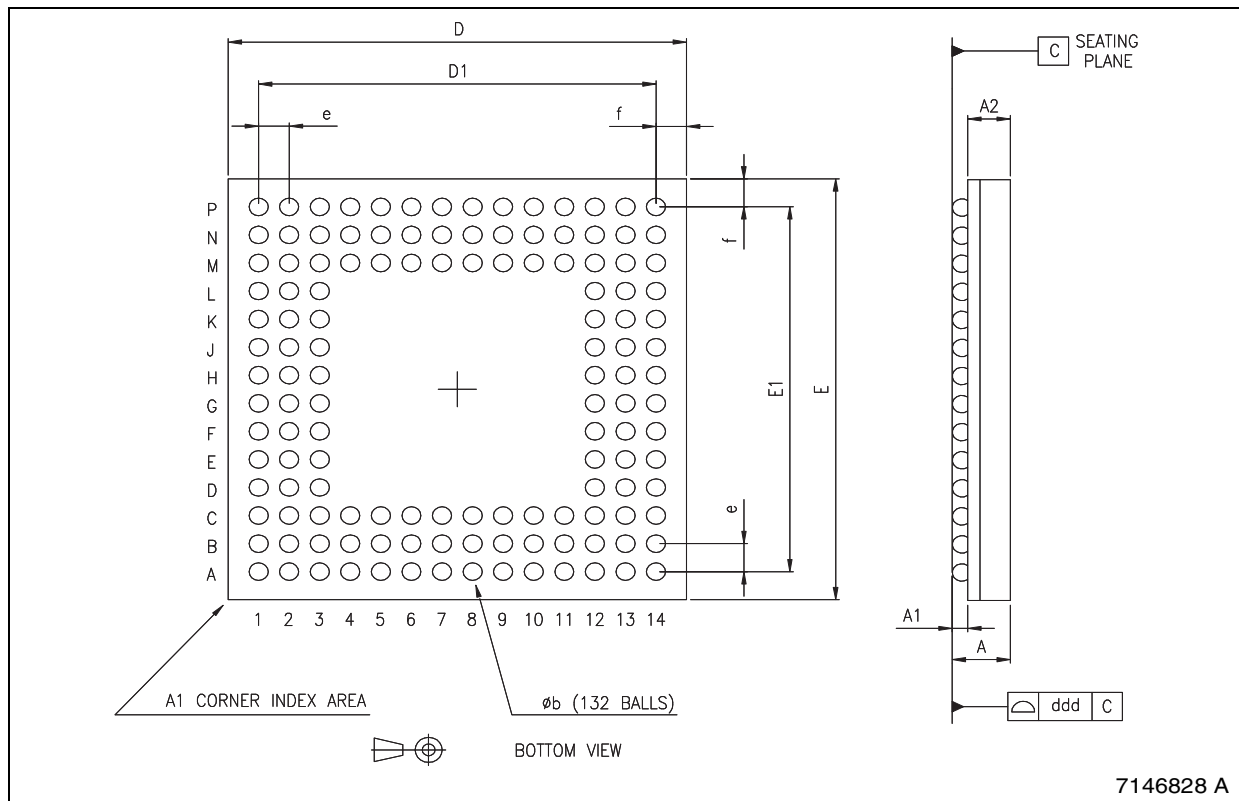

Information furnished is believed to be accurate and reliable. However, STMicroelectronics assumes no responsibility for the consequences of use of such information nor for any infringement of patents or other rights of third parties which may result from its use. No license is granted by implication or otherwise under any patent or patent rights of STMicroelectronics. Specifications mentioned in this publication are subject to change without notice. This publication supersedes and replaces all information previously supplied. STMicroelectronics products are not authorized for use as critical components in life support devices or systems without express written approval of STMicroelectronics.

The ST logo is a registered trademark of STMicroelectronics.

The BLUETOOTH® word mark and logos are owned by the Bluetooth SIG, Inc. and any use of such marks by STMicroelectronics is under license. All other names are the property of their respective owners

© 2004 STMicroelectronics - All rights reserved

STMicroelectronics GROUP OF COMPANIES

Australia - Belgium - Brazil - Canada - China - Czech Republic - Finland - France - Germany - Hong Kong - India - Israel - Italy - Japan - Malaysia - Malta - Morocco - Singapore - Spain - Sweden - Switzerland - United Kingdom - United States

www.st.com