



16-Bit, RISC, Microcontroller-Based, Ultrasonic Distance-Measuring System

MAXQ7667

General Description

The MAXQ7667 smart system-on-a-chip (SoC) provides a time-of-flight ultrasonic distance-measuring solution. The device is optimized for applications involving large distance measurement with weak input signals or multiple target identification. The MAXQ7667 features high signal-to-noise ratio achieved by combining flexible electronics with the intelligence necessary to optimize each function as environmental and target conditions change.

An integrated burst signal generator and echo reception components process ultrasonic signals between 25kHz and 100kHz. Echo reception components include a programmable gain low-noise amplifier (LNA), a 16-bit sigma-delta ADC to digitize the received echo signals, and digital signal processing (DSP). DSP limits noise with a bandpass filter, and creates an echo envelope through demodulation and lowpass filtering. Input referred noise is a low 0.7 μ V_{RMS}. A programmable phase-locked loop (PLL) frequency synthesizer supplies the reference frequency for the burst generator and the clock for the echo receiver's digital filter. An embedded 16-bit MAXQ20 microcontroller (μ C) controls all the preceding functions.

The μ C optimizes the burst frequency and reception frequency for each transmission at any temperature. The MAXQ7667 achieves smart sensing by monitoring the echo signals and then actively changing the transmitted and received parameters to obtain optimum results. Digital filtering and burst synthesis do not require CPU intervention. This leaves all the CPU power available for echo optimization, communication, diagnostics, and additional signal processing.

The MAXQ7667 operates with three different power supply voltages: +5V, +3.3V, and +2.5V. Two internal linear regulators allow operation from a single +5V supply when three external power supplies are not available. Alternatively, the MAXQ7667 can control an external pass transistor to allow operation from a single supply voltage of +8V to +65V or more, depending on the external component tolerance. The device is available in a 48-pin LQFP package and is specified to operate from -40°C to +125°C.

Applications

Automotive Parking Automation
Vehicle Security Handheld Devices
Industrial Processing

Note: Some revisions of this device may incorporate deviations from published specifications known as errata. Multiple revisions of any device may be simultaneously available through various sales channels. For information about device errata, go to: www.maxim-ic.com/errata.



For pricing, delivery, and ordering information, please contact Maxim Direct at 1-888-629-4642, or visit Maxim's website at www.maxim-ic.com.

Features

- ◆ Smart Analog Peripherals
 - Dedicated Ultrasonic Burst Generator
 - Echo Receiving Path (Includes LNA, Sigma-Delta ADC)
 - 5-Channel, 12-Bit SAR ADC with 250ksps Sampling Rate
 - Internal Bandgap Voltage Reference for the ADCs (Also Accepts External Voltage Reference)
- ◆ Timer/Digital I/O Peripherals
- ◆ High-Performance, Low-Power, 16-Bit RISC Core
- ◆ Program and Data Memory
- ◆ Crystal/Clock Module
- ◆ 16 x 16 Hardware Multiplier with 48-Bit Accumulator, Single Clock Cycle
- ◆ Power-Management Module
- ◆ JTAG Interface
- ◆ Universal Asynchronous Receiver-Transmitter (UART)
- ◆ Local Interconnect Network (LIN)

See the Detailed Features section for complete list of features.

Ordering Information

PART	PIN-PACKAGE	RAM (KB)	FLASH (KB)
MAXQ7667AACM/V+	48 LQFP	4	32

Note: All devices are specified over the -40°C to +125°C operating temperature range.

/V denotes an automotive qualified part.

+Denotes a lead(Pb)-free/RoHS-compliant package.

Pin Configuration appears at end of data sheet.

16-Bit, RISC, Microcontroller-Based, Ultrasonic Distance-Measuring System

ABSOLUTE MAXIMUM RATINGS

DVDDIO, GATE5, REG3P3, REG2P5 to DGND	-0.3V to +6.0V	Analog Inputs/Outputs to AGND	-0.3V to (V _{AVDD} + 0.3V)
AVDD to AGND	-0.3V to +4.0V	XIN, XOUT to DGND	-0.3V to (V _{DVDD} + 0.3V)
DVDD to DGND	-0.3V to +3.0V	Maximum Current into Any Pin.....	50mA
DVDDIO to DVDD	-0.3V to +6.0V	Continuous Power Dissipation (T _A = +70°C)	
AVDD to DVDD	-0.3V to +4.0V	48-Pin LQFP (derate 21.7mW/°C above +70°C).....	1739.1mW
AGND to DGND	-0.3V to +0.3V	Operating Temperature Range	-40°C to +125°C
Digital Inputs/Outputs to DGND.....	-0.3V to (V _{DVDDIO} + 0.3V)	Storage Temperature Range	-60°C to +150°C
		Lead Temperature (soldering, 10s)	+300°C

Stresses beyond those listed under "Absolute Maximum Ratings" may cause permanent damage to the device. These are stress ratings only, and functional operation of the device at these or any other conditions beyond those indicated in the operational sections of the specifications is not implied. Exposure to absolute maximum rating conditions for extended periods may affect device reliability.

ELECTRICAL CHARACTERISTICS

(V_{DVDDIO} = +5V, V_{AVDD} = +3.3V; V_{DVDD} = +2.5V, system clock (f_{SYSCLOCK}) = 16MHz, burst frequency (f_{BURST}) = bandpass frequency (f_{BPF}) = 50kHz, C_{REFBG} = C_{REF} = 1μF in parallel with 0.01μF, f_{ADCCLK} = 2MHz (SAR data rate = 125ksps), T_A = T_{MIN} to T_{MAX}, unless otherwise specified. Typical values are at T_A = +25°C.)

PARAMETER	SYMBOL	CONDITIONS	MIN	TYP	MAX	UNITS
ECHO INPUT (Low-Noise Amplifier and Sigma-Delta ADC)						
Input-Referred Noise (Note 1)		VGA gain adjust = 1.55μV _{P-P} /LSB		5.6		μV _{RMS}
		VGA gain adjust = 0.1μV _{P-P} /LSB		0.7		
Minimum Detectable Signal		VGA gain adjust = 1.55μV _{P-P} /LSB		80		μV _{P-P}
		VGA gain adjust = 0.1μV _{P-P} /LSB		10		
Operating Input Range		VGA gain adjust = 1.55μV _{P-P} /LSB, unclipped		100		mV _{P-P}
		VGA gain adjust = 0.1μV _{P-P} /LSB, unclipped		6.7		
Programmable Gain		From echo input to bandpass filter in reply to input	VGA gain adjust = 1.55μV _{P-P} /LSB	1.55		μV _{P-P} /LSB
			VGA gain adjust = 0.1μV _{P-P} /LSB	0.1		
Programmable-Gain Adjust Resolution		(Note 2)		10		%
LNA Bandwidth				150		kHz
ADC Sampling Rate				80 x f _{BPF}		kHz
ADC Output Data Rate				10 x f _{BPF}		kHz
ADC Output Data Resolution				16		Bits
Echo-Input Resistance	R _{IN}	For each echo input		14		kΩ
Echo-Input Capacitance				14		pF
Echo-Input DC Bias Voltage				V _{AVDD} /2		V
Maximum Overvoltage Recovery Time		Recover from 2V _{P-P} input		10		μs

16-Bit, RISC, Microcontroller-Based, Ultrasonic Distance-Measuring System

MAXQ7667

ELECTRICAL CHARACTERISTICS (continued)

($V_{DDIO} = +5V$, $V_{AVDD} = +3.3V$; $V_{DVDD} = +2.5V$, system clock (f_{SYSCLK}) = 16MHz, burst frequency (f_{BURST}) = bandpass frequency (f_{BPF}) = 50kHz, $C_{REFBG} = C_{REF} = 1\mu F$ in parallel with $0.01\mu F$, $f_{ADCCLK} = 2MHz$ (SAR data rate = 125ksps), $T_A = T_{MIN}$ to T_{MAX} , unless otherwise specified. Typical values are at $T_A = +25^\circ C$.)

PARAMETER	SYMBOL	CONDITIONS	MIN	TYP	MAX	UNITS
BANDPASS FILTER						
Center Frequency	f_{BPF}		25		100	kHz
Passband Width		-3dB		$0.14 \times f_{BPF}$		kHz
Minimum Stopband Rejection		One decade away from center frequency		-60		dB
Output Data Rate				$10 \times f_{BPF}$		ksps
Output Data Resolution				16		Bits
LOWPASS FILTER						
Corner Frequency	f_{LPF}	-3dB		$0.1 \times f_{BPF}$		kHz
Rolloff				40		dB/Decade
Output Data Rate				$5 \times f_{BPF}$		ksps
Output Data Resolution				16		Bits
SAR ADC						
Resolution		Measurement	12			Bits
		No missing codes	11			
Integral Nonlinearity		Tested at 125ksps		± 1	± 2	LSB
Differential Nonlinearity		Tested at 125ksps	-2		+2	LSB
Offset Error				± 1	± 3	mV
Offset-Error Drift				± 5		$\mu V/^\circ C$
Gain Error					± 1	%
Gain-Error Temperature Coefficient				± 0.4		ppmFS/ $^\circ C$
Input-Referred Noise		At ADC inputs		400		μV_{RMS}
Differential Input Range		Unipolar	0		V_{REF}	V
		Bipolar	$-V_{REF}/2$		$+V_{REF}/2$	
Absolute Input Range			0		V_{AVDD}	V
Input Leakage Current				± 0.1		μA
Conversion Time		13 ADCCLK cycles at 2MHz			6.5	μs
Input Capacitance				14		pF
Track-and-Hold Acquisition Time		Three ADCCLK cycles at 2MHz			1.5	μs
Turn-On Time		Eight ADCCLK cycles at 2MHz			4	μs
Conversion Clock	f_{ADCCLK}		0.5		4	MHz
Conversion Rate		$f_{ADCCLK} = 4MHz$ (not production tested)			250	ksps

16-Bit, RISC, Microcontroller-Based, Ultrasonic Distance-Measuring System

ELECTRICAL CHARACTERISTICS (continued)

($V_{DDIO} = +5V$, $V_{AVDD} = +3.3V$; $V_{DVDD} = +2.5V$, system clock (f_{SYSCLK}) = 16MHz, burst frequency (f_{BURST}) = bandpass frequency (f_{BPF}) = 50kHz, $C_{REFBG} = C_{REF} = 1\mu F$ in parallel with $0.01\mu F$, $f_{ADCCLK} = 2MHz$ (SAR data rate = 125ksps), $T_A = T_{MIN}$ to T_{MAX} , unless otherwise specified. Typical values are at $T_A = +25^\circ C$.)

PARAMETER	SYMBOL	CONDITIONS	MIN	TYP	MAX	UNITS
REFERENCE BUFFER						
Offset				5		mV
Minimum Load			2.5			k Ω
Output Bypass Capacitor				0.47		μF
EXTERNAL VOLTAGE REFERENCE (Reference Buffer Disabled)						
Reference Input Range		Applied at REF	1.0		V_{AVDD}	V
Reference Input Impedance		Measured at REF with the SAR and sigma-delta ADCs running at maximum frequency		50		k Ω
INTERNAL VOLTAGE REFERENCE (REFBG)						
Initial Accuracy			2.45	2.5	2.55	V
Maximum Temperature Coefficient				100		ppm/ $^\circ C$
Output Impedance				1.1		k Ω
Power-Supply Rejection Ratio		$V_{AVDD} = 3.0V$ to $3.6V$		60		dB
Output Noise				0.5		mV _{RMS}
PROGRAMMABLE BURST-FREQUENCY OSCILLATOR						
Burst-Frequency Range			0.025		1.335	MHz
Burst-Frequency Resolution				0.1		%
Burst-Frequency Locking Time		Change from 40kHz to 60kHz		5		ms
		Change from 50kHz to 50.5kHz		2		
CRYSTAL OSCILLATOR						
Frequency Range		Tested crystal frequency		16		MHz
		Minimum crystal frequency		4		
		External clock input	4		16	
Temperature Stability		Excluding crystal		25		ppm/ $^\circ C$
Startup Time		16MHz crystal		10		ms
XIN Input Low Voltage		When driven with external clock source			$0.3 \times V_{DVDD}$	V
XIN Input High Voltage		When driven with external clock source	$0.7 \times V_{DVDD}$			V
INTERNAL RC OSCILLATOR						
Frequency				13.5		MHz
Initial Accuracy				10.5		%
Temperature Drift		$T_A = T_{MIN}$ to T_{MAX}		700		ppm
Supply Rejection		$V_{DVDD} = 2.25V$ to $2.75V$		-1.5		%

16-Bit, RISC, Microcontroller-Based, Ultrasonic Distance-Measuring System

MAXQ7667

ELECTRICAL CHARACTERISTICS (continued)

($V_{DVDDIO} = +5V$, $V_{AVDD} = +3.3V$; $V_{DVDD} = +2.5V$, system clock (f_{SYSCLK}) = 16MHz, burst frequency (f_{BURST}) = bandpass frequency (f_{BPF}) = 50kHz, $C_{REFBG} = C_{REF} = 1\mu F$ in parallel with $0.01\mu F$, $f_{ADCCLK} = 2MHz$ (SAR data rate = 125ksps), $T_A = T_{MIN}$ to T_{MAX} , unless otherwise specified. Typical values are at $T_A = +25^\circ C$.)

PARAMETER	SYMBOL	CONDITIONS	MIN	TYP	MAX	UNITS
Adjustable Frequency Range		Using the RCTRM register	-40		+40	%
Frequency Adjustment Resolution				0.2		%
SUPPLY VOLTAGE SUPERVISORS						
DVDD Reset Threshold		Asserts \overline{RESET} if V_{DVDD} falls below this threshold	2.10		2.25	V
DVDD Interrupt Threshold		Generates an interrupt if V_{DVDD} falls below this threshold	2.25		2.38	V
Minimum Reset and Interrupt Threshold Difference			150			mV
AVDD Interrupt Threshold		Generates an interrupt if V_{AVDD} falls below this threshold	2.95		3.15	V
DVDDIO Interrupt Threshold		Generates an interrupt if V_{DVDDIO} falls below this threshold	4.5		4.75	V
Supervisor Operating Range		At DVDD	1.5		2.75	V
Supervisor Hysteresis				1		%
\overline{RESET} Release Delay		After V_{DVDD} rises above the reset threshold		35		μs
Power-Up Time		Time from \overline{RESET} is released to the execution of the first instruction (serial bootloader off)		1		μs
+5V LINEAR REGULATOR (DVDDIO, GATE5, Requires External Pass Transistor, see the <i>Typical Application Circuit/Functional Diagram</i>)						
Regulator Output Voltage		At DVDDIO	4.75		5.25	V
GATE5 Output High Voltage		$I_{SOURCE} = 0\mu A$ (no load)	$V_{DVDDIO} - 0.1$			V
GATE5 Output Low Voltage		$I_{SINK} = 500\mu A$			2	V
GATE5 Output Resistance		$I_{SINK} = 0\mu A$ to $50\mu A$		330		Ω
Gain Bandwidth		DVDDIO to GATE5		1.58		kHz
Gain		DVDDIO to GATE5		1700		V/V
GATE5 Slew Rate				4.3		V/ms
Maximum Load Capacitance		Maximum capacitance on DVDDIO when using an external pass transistor		1		μF
+3.3V LINEAR REGULATOR (REG3P3)						
REG3P3 Output Voltage			3.15		3.45	V
Load Current					50	mA
Output Short-Circuit Current		REG3P3 shorted to AGND		150		mA

16-Bit, RISC, Microcontroller-Based, Ultrasonic Distance-Measuring System

ELECTRICAL CHARACTERISTICS (continued)

($V_{DVDDIO} = +5V$, $V_{AVDD} = +3.3V$; $V_{DVDD} = +2.5V$, system clock (f_{SYSCLK}) = 16MHz, burst frequency (f_{BURST}) = bandpass frequency (f_{BPF}) = 50kHz, $C_{REFBG} = C_{REF} = 1\mu F$ in parallel with $0.01\mu F$, $f_{ADCCLK} = 2MHz$ (SAR data rate = 125ksps), $T_A = T_{MIN}$ to T_{MAX} , unless otherwise specified. Typical values are at $T_A = +25^\circ C$.)

PARAMETER	SYMBOL	CONDITIONS	MIN	TYP	MAX	UNITS
+2.5V LINEAR REGULATOR (REG2P5)						
REG2P5 Output Voltage			2.38		2.62	V
Load Current					50	mA
Output Short-Circuit Current		REG2P5 shorted to DGND		100		mA
POWER REQUIREMENTS						
Supply Voltage Range		DVDD	2.25	2.5	2.75	V
		AVDD	3.00	3.3	3.6	
		DVDDIO	4.5	5.0	5.5	
AVDD Supply Current		All analog functions enabled		12	18	mA
		All analog functions disabled		3	10	μA
		Incremental AVDD supply current	LNA		2.4	mA
			Sigma-delta ADC		12	
			SAR ADC, 250ksps, $f_{ADCCLK} = 4MHz$		600	μA
			PLL		300	
			Supply voltage supervisors		3	
			Internal voltage reference		220	
			Reference buffer		300	
	Bias (any AVDD module enabled)			1.5	mA	
DVDD Supply Current				11		mA
DVDDIO Supply Current				2.5		mA
DIGITAL INPUTS (GPIO, UART, JTAG, SPI™)						
Input High Voltage			$V_{DVDDIO} - 1$			V
Input Low Voltage					0.8	V
Input Hysteresis		$V_{DVDDIO} = 5.0V$		500		mV
Input Leakage Current		Digital input voltage = DGND or DVDDIO, pullup disabled		± 0.01	± 1	μA
Pullup/Pulldown Resistance		Pulled up to DVDDIO internally, pulled down to DGND internally		150		$k\Omega$
Input Capacitance				15		pF

SPI is a trademark of Motorola, Inc.

16-Bit, RISC, Microcontroller-Based, Ultrasonic Distance-Measuring System

MAXQ7667

ELECTRICAL CHARACTERISTICS (continued)

($V_{DVDDIO} = +5V$, $V_{AVDD} = +3.3V$; $V_{DVDD} = +2.5V$, system clock (f_{SYSCLK}) = 16MHz, burst frequency (f_{BURST}) = bandpass frequency (f_{BPF}) = 50kHz, $C_{REFBG} = C_{REF} = 1\mu F$ in parallel with $0.01\mu F$, $f_{ADCCLK} = 2MHz$ (SAR data rate = 125ksps), $T_A = T_{MIN}$ to T_{MAX} , unless otherwise specified. Typical values are at $T_A = +25^\circ C$.)

PARAMETER	SYMBOL	CONDITIONS	MIN	TYP	MAX	UNITS
DIGITAL OUTPUTS (GPIO, UART, JTAG, SPI)						
Output Low Voltage		$I_{SINK} = 0.5mA$, drive strength = low			0.4	V
		$I_{SINK} = 1.0mA$, drive strength = high			0.4	
Output High Voltage		$I_{SOURCE} = 0.5mA$, drive strength = low	$V_{DVDDIO} - 0.5$			V
		$I_{SOURCE} = 1.0mA$, drive strength = high	$V_{DVDDIO} - 0.5$			
Maximum Output Impedance		Drive strength = low		880		Ω
		Drive strength = high		450		
Three-State Leakage				± 0.01	± 1	μA
Three-State Capacitance				15		pF
BURST OUTPUT						
Output Low Voltage		$I_{SINK} = 8mA$			0.4	V
Output High Voltage		$I_{SOURCE} = 8mA$	$V_{DVDDIO} - 0.5$			V
Maximum Output Impedance		Drive strength = low		90		Ω
		Drive strength = high		45		
Three-State Leakage				± 0.01	± 1	μA
Three-State Capacitance				15		pF
Short-Circuit Current		Burst drive set to high		50		mA
RESET						
Internal Pullup Resistance		Pulled up to DVDDIO		120		k Ω
Output Low Voltage		$I_{SINK} = 0.5mA$			0.4	V
Output High Voltage		No external load	$V_{DVDDIO} - 0.5$			V
Input Low Voltage		When driven by external source			0.8	V
Input High Voltage		When driven by external source	$V_{DVDDIO} - 1$			V
UART/LIN INTERFACE (UTX, URX)						
UART Baud Rates		Asynchronous mode (system clock/32)			500	kpbs
		Synchronous mode (system clock/8)			2000	
		LIN 2.0 compatibility (Note 3)	1		20	

16-Bit, RISC, Microcontroller-Based, Ultrasonic Distance-Measuring System

ELECTRICAL CHARACTERISTICS (continued)

($V_{DDIO} = +5V$, $V_{AVDD} = +3.3V$; $V_{DVDD} = +2.5V$, system clock (f_{SYSCLK}) = 16MHz, burst frequency (f_{BURST}) = bandpass frequency (f_{BPF}) = 50kHz, $C_{REFBG} = C_{REF} = 1\mu F$ in parallel with $0.01\mu F$, $f_{ADCCLK} = 2MHz$ (SAR data rate = 125ksps), $T_A = T_{MIN}$ to T_{MAX} , unless otherwise specified. Typical values are at $T_A = +25^\circ C$.)

PARAMETER	SYMBOL	CONDITIONS	MIN	TYP	MAX	UNITS
SPI INTERFACE TIMING (Figures 11 and 12)						
SPI Master Operating Frequency	$1/t_{MCK}$	$0.5 \times f_{SYSCLK}$			8	MHz
SPI Slave Operating Frequency	$1/t_{SCK}$	$0.25 \times f_{SYSCLK}$			4	MHz
SCLK Output Pulse-Width High/Low	t_{MCH} , t_{MCL}		$t_{MCK}/2$ - 25			ns
MOSI Output Hold Time After SCLK Sample Edge	t_{MOH}		$t_{MCK}/2$ - 25			ns
MOSI Output Valid to Sample Edge	t_{MOV}		$t_{MCK}/2$ - 25			ns
MISO Input Valid to SCLK Sample Edge	t_{MIS}		25			ns
MISO Input Hold Time After SCLK Sample Edge	t_{MIH}		0			ns
SCLK Inactive to MOSI Inactive	t_{MLH}		0			ns
SCLK Input Pulse-Width High/Low	t_{SCH} , t_{SCL}			$t_{SCK}/2$		ns
SS Active to First Shift Edge	t_{SSE}		$4t_{SYSCLK}$			ns
MOSI Input Setup Time to SCLK Sample Edge	t_{SIS}		25			ns
MOSI Input Hold Time After SCLK Sample Edge	t_{SIH}		25			ns
MISO Output Valid After SCLK Shift Edge Transition	t_{SOV}				50	ns
SS Inactive Duration	t_{SSH}		$t_{SYSCLK} +$ 25			ns
SCLK Inactive to SS Rising Edge	t_{SD}		$t_{SYSCLK} +$ 25			ns
FLASH PROGRAMMING						
Flash Erase Time		Mass erase	200			ms
		Page erase (512 bytes per page)	20			
Flash Programming Time		20 μ s per word	657			ms
Write/Erase Cycles			10,000			Cycles
Data Retention		Average temperature = +85 $^\circ$ C	15			Years

Note 1: Noise measured at bandpass filter output with ECHO+ and ECHO- shorted divided by the gain with $f_{BPF} = 50kHz$.

Note 2: Gain adjust resolution typically ranges between 6.25% and 12.5%.

Note 3: LIN 2.0 specifies a maximum data rate of 20kbps. Higher data rates could be possible with compatible devices and suitable line conditions.

16-Bit, RISC, Microcontroller-Based, Ultrasonic Distance-Measuring System

MAXQ7667

Typical Operating Characteristics

($V_{DDIO} = +5V$, $V_{AVDD} = +3.3V$, $V_{DVDD} = +2.5V$, $f_{SYSCLK} = 16MHz$, burst frequency = bandpass frequency = 50kHz, $T_A = +25^\circ C$, unless otherwise noted.)

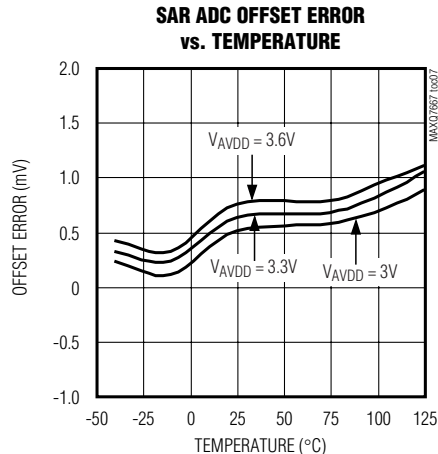
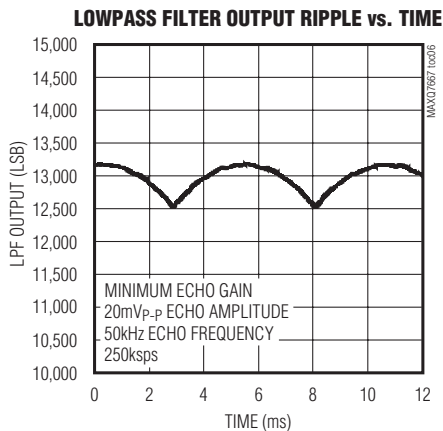
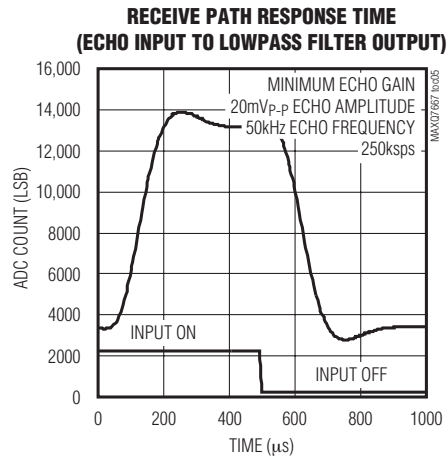
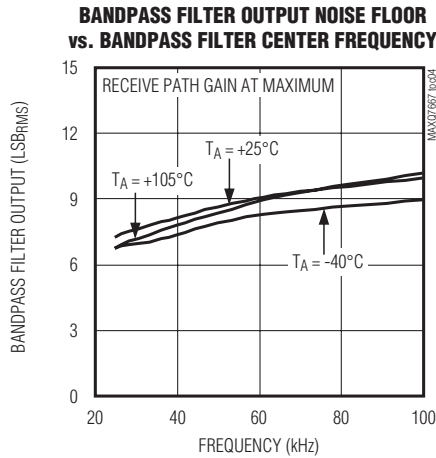
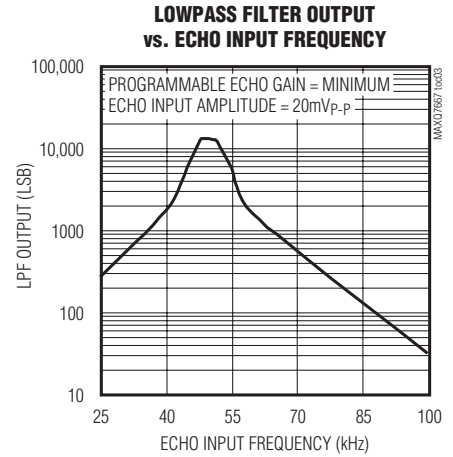
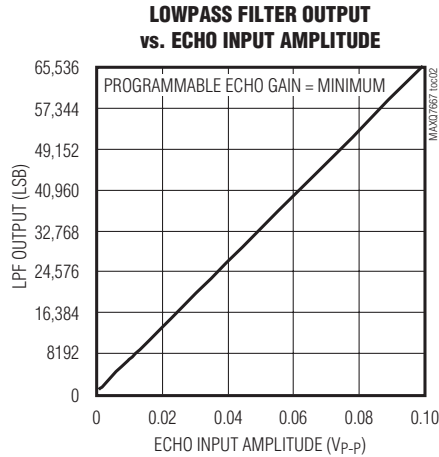
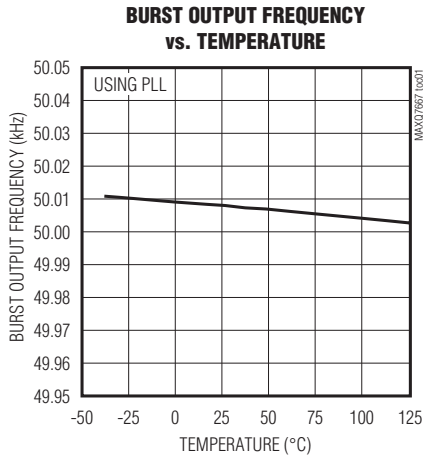

16-Bit, RISC, Microcontroller-Based, Ultrasonic Distance-Measuring System

Typical Operating Characteristics (continued)

($V_{DVDDIO} = +5V$, $V_{AVDD} = +3.3V$, $V_{DVDD} = +2.5V$, $f_{SYSCLK} = 16MHz$, burst frequency = bandpass frequency = 50kHz, $T_A = +25^\circ C$, unless otherwise noted.)

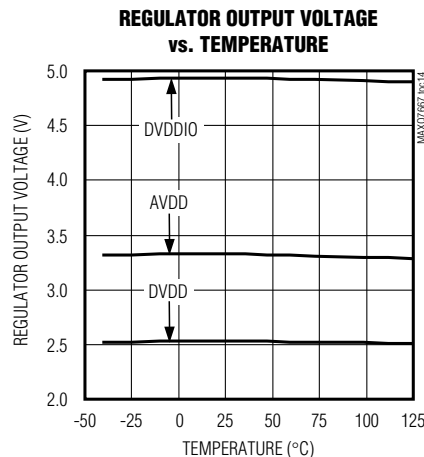
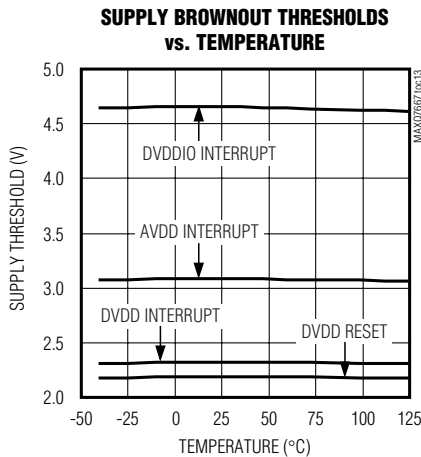
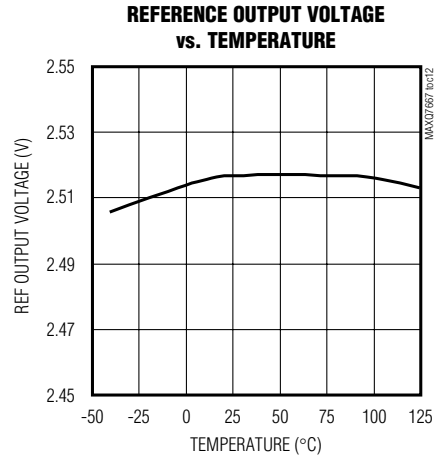
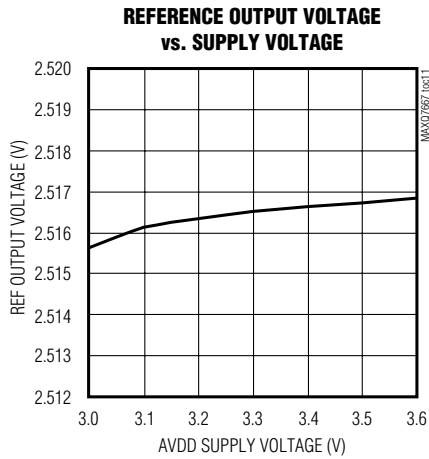
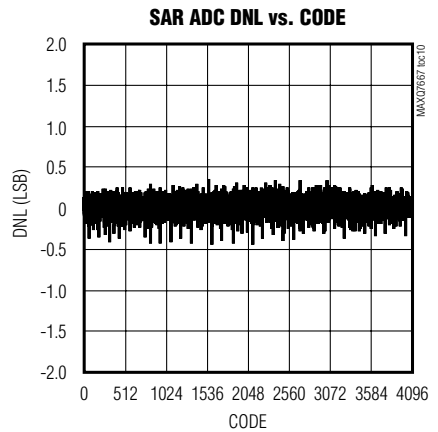
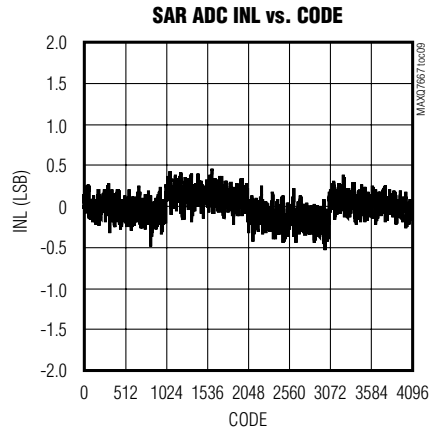
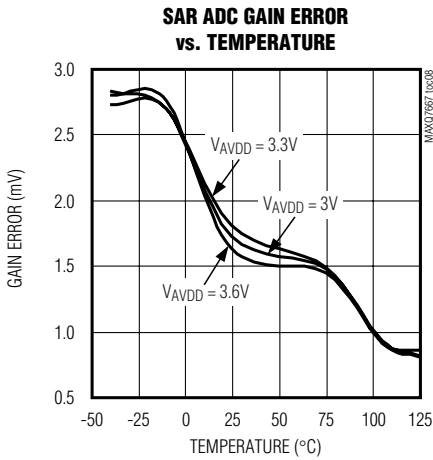

16-Bit, RISC, Microcontroller-Based, Ultrasonic Distance-Measuring System

MAXQ7667

Typical Operating Characteristics (continued)

($V_{DVDDIO} = +5V$, $V_{AVDD} = +3.3V$, $V_{DVDD} = +2.5V$, $f_{SYSCLK} = 16MHz$, burst frequency = bandpass frequency = 50kHz, $T_A = +25^\circ C$, unless otherwise noted.)

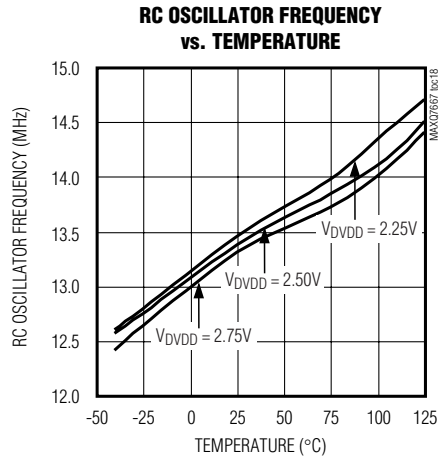
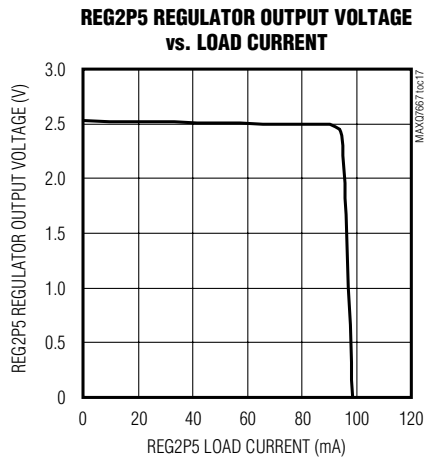
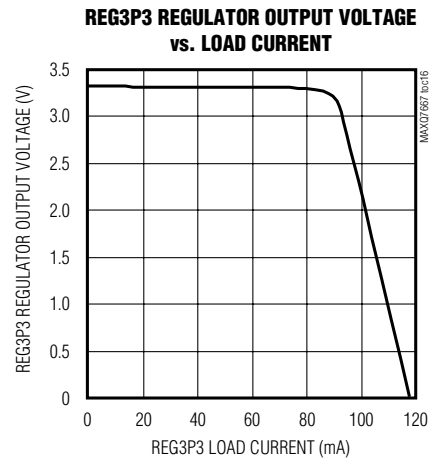
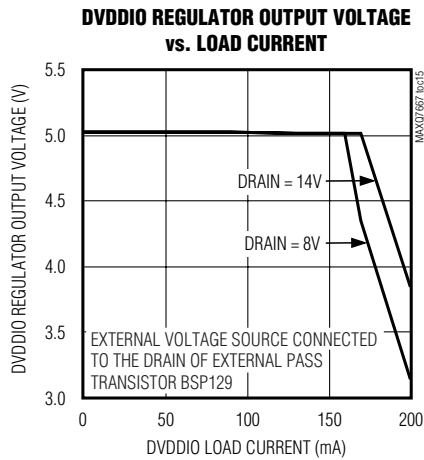

16-Bit, RISC, Microcontroller-Based, Ultrasonic Distance-Measuring System

Pin Description

PIN	NAME	FUNCTION
1	P1.3/TCK	Port 1 Data 3/JTAG Serial Clock Input. P1.3 is a general-purpose digital I/O. TCK is the JTAG serial test clock input. Refer to the <i>MAXQ7667 User's Guide</i> Sections 5 and 11.
2	P1.4/MOSI	Port 1 Data 4/SPI Serial Data Output. P1.4 is a general-purpose digital I/O. MOSI is the master output, slave input for the SPI interface. Refer to the <i>MAXQ7667 User's Guide</i> Sections 5 and 9.
3	P1.5/MISO	Port 1 Data 5/SPI Serial Data Input. P1.5 is a general-purpose digital I/O. MISO is the master input, slave output for the SPI interface. Refer to the <i>MAXQ7667 User's Guide</i> Sections 5 and 9.
4	P1.6/SCLK	Port 1 Data 6/SPI Serial Clock Output. P1.6 is a general-purpose digital I/O. SCLK is the serial clock for the SPI interface. SCLK is an input when operating as a slave and an output when operating as a master. Refer to the <i>MAXQ7667 User's Guide</i> Sections 5 and 9.
5	P1.7/SYNC/SS	Port 1 Data 7/Schedule Timer Sync Input/SPI Slave Select. P1.7 is a general-purpose digital I/O. A rising edge on the SYNC input resets the schedule timer. In SPI slave mode, SS is the SPI slave-select input. In SPI master mode, use SS or a GPIO to manually select an external slave. Refer to the <i>MAXQ7667 User's Guide</i> Sections 5, 7, and 9.
6, 19, 42	DVDD	Digital Supply Voltage. Connect DVDD directly to a +2.5V external source or to REG2P5 output for single supply operation. Bypass DVDD to DGND with a 0.1µF capacitor as close as possible to the device. Connect all DVDD nodes together.
7, 18, 43	DGND	Digital Ground. Connect all DGND nodes together. Connect to AGND at a single point.
8, 17, 44	DVDDIO	Digital I/O Supply Voltage. DVDDIO powers all digital I/Os except for XIN and XOUT. Bypass DVDDIO to DGND with a 0.1µF capacitor as close as possible to the device. Connect all DVDDIO nodes together.
9	P0.0/URX	Port 0 Data 0/UART Receive Data Input. P0.0 is a general-purpose digital I/O. URX is a UART or LIN data receive input. Refer to the <i>MAXQ7667 User's Guide</i> Sections 5 and 8.
10	P0.1/UTX	Port 0 Data 1/UART Transmit Data Output. P0.1 is a general-purpose digital I/O. UTX is a UART or LIN data transmit output. Refer to the <i>MAXQ7667 User's Guide</i> Sections 5 and 8.
11	P0.2/ $\overline{\text{TXEN}}$	Port 0 Data 2/UART Transmit Output. P0.2 is a general-purpose digital I/O. $\overline{\text{TXEN}}$ asserts low when the UART is transmitting. Use $\overline{\text{TXEN}}$ to enable an external LIN/UART transceiver. Refer to the <i>MAXQ7667 User's Guide</i> Sections 5 and 8.
12	P0.3/T0/ ADCCTL	Port 0 Data 3/Timer 0 I/O/ADC Control Input. P0.3 is a general-purpose digital I/O. T0 is the primary Type 2 timer/counter 0 output or input. ADCCTL is a sampling/conversion trigger input for the SAR ADC. Refer to the <i>MAXQ7667 User's Guide</i> Sections 5, 6, and 14.
13	P0.4/T0B	Port 0 Data 4/Timer 0B I/O/Comparator Output. P0.4 is a general-purpose digital I/O. T0B is the secondary Type 2 timer/counter 0 output or input. Refer to the <i>MAXQ7667 User's Guide</i> Sections 5 and 6.
14	P0.5/T1	Port 0 Data 5/Timer 1 I/O. P0.5 is a general-purpose digital I/O. T1 is the primary Type 2 timer/counter 1 output or input. Refer to the <i>MAXQ7667 User's Guide</i> Sections 5 and 6.
15	P0.6/T2	Port 0 Data 6/Timer 2 I/O. P0.6 is a general-purpose digital I/O. T2 is the primary Type 2 timer/counter 2 output or input. Refer to the <i>MAXQ7667 User's Guide</i> Sections 5 and 6.
16	P0.7/T2B	Port 0 Data 7/Timer 2B I/O. P0.7 is a general-purpose digital I/O. T2B is the secondary Type 2 timer/counter 2 output or input. Refer to the <i>MAXQ7667 User's Guide</i> Sections 5 and 6.
20	XIN	Crystal Oscillator Input. Connect an external crystal or resonator between XIN and XOUT. When using an external clock source drive XIN with 2.5V level clock while leaving XOUT unconnected. Connect XIN to DGND when an external clock source is not used.

16-Bit, RISC, Microcontroller-Based, Ultrasonic Distance-Measuring System

Pin Description (continued)

MAXQ7667

PIN	NAME	FUNCTION
21	XOUT	Crystal Oscillator Output. Connect an external crystal or resonator between XIN and XOUT. Leave XOUT unconnected when driving XIN with a 2.5V level clock or when an external clock source is not used.
22	REG2P5	+2.5V Voltage Regulator Output
23	REG3P3	+3.3V Voltage Regulator Output
24	GATE5	+5V DVDDIO Voltage Regulator Control Output. GATE5 controls an external npn or nMOS transistor that passes power to DVDDIO.
25	RESET	Reset Input/Output. RESET is open drain with an internal pullup resistor to DVDDIO. Internal circuitry pulls RESET low when VD _{VDDIO} falls below its brownout reset value or watchdog reset is enabled and the watchdog timeout period expires. Force RESET low externally for manual reset.
26	FILT	PLL VCO Control Input. Connect external filter components on FILT for the internal PLL circuit. See the <i>Typical Application Circuit/Functional Diagram</i> .
27, 32	AVDD	Analog Supply Voltage. Connect all AVDD inputs directly to a +3.3V source or to REG3P3 for self-powered operation. Bypass each AVDD to AGND with a 0.1μF capacitor as close as possible to the device.
28, 31, 33	AGND	Analog Ground. Connect all AGND nodes together. Connect to DGND at a single point.
29	ECHON	Negative Echo Input. AC-couple ECHON to an ultrasonic transducer.
30	ECHOP	Positive Echo Input. AC-couple ECHOP to an ultrasonic transducer.
34	REF	ADC Reference Input/Reference Buffer Output. When using the internal reference, the buffered bandgap reference voltage (V _{REF}) is provided for both SAR and sigma-delta ADCs. When using an external reference, apply an external voltage source ranging between 1V and V _{AVDD} at REF. Disable the reference buffer when applying an external reference at REF. Bypass REF to AGND with a 0.47μF capacitor.
35	REFBG	+2.5V Reference Output/Reference Buffer Input. Bypass to AGND with a 0.47μF capacitor.
36	AIN0	SAR ADC Input 0. AIN0 pairs with AIN1 in differential mode.
37	AIN1	SAR ADC Input 1. AIN1 pairs with AIN0 in differential mode.
38	AIN2	SAR ADC Input 2. AIN2 pairs with AIN3 in differential mode.
49	AIN3	SAR ADC Input 3. AIN3 pairs with AIN2 in differential mode.
40	AIN4	SAR ADC Input 4
41	N.C.	No Connection. Internally connected. Leave unconnected.
45	BURST	Burst Output. Burst is the ultrasonic transducer excitation pulse output. BURST remains in three-state mode on power-up.
46	P1.0/TDO	Port 1 Data 0/JTAG Output. P1.0 is a general-purpose digital I/O. TDO is the JTAG serial data output. Refer to the <i>MAXQ7667 User's Guide</i> Sections 5 and 11.
47	P1.1/TMS	Port 1 Data 1/JTAG Test Mode-Select Input. P1.1 is a general-purpose digital I/O. TMS is the JTAG mode-select input. Refer to the <i>MAXQ7667 User's Guide</i> Sections 5 and 11.
48	P1.2/TDI	Port 1 Data 2/JTAG Input. P1.2 is a general-purpose digital I/O. TDI is the JTAG serial data input. Refer to the <i>MAXQ7667 User's Guide</i> Sections 5 and 11.

16-Bit, RISC, Microcontroller-Based, Ultrasonic Distance-Measuring System

Typical Application Circuit/Functional Diagram

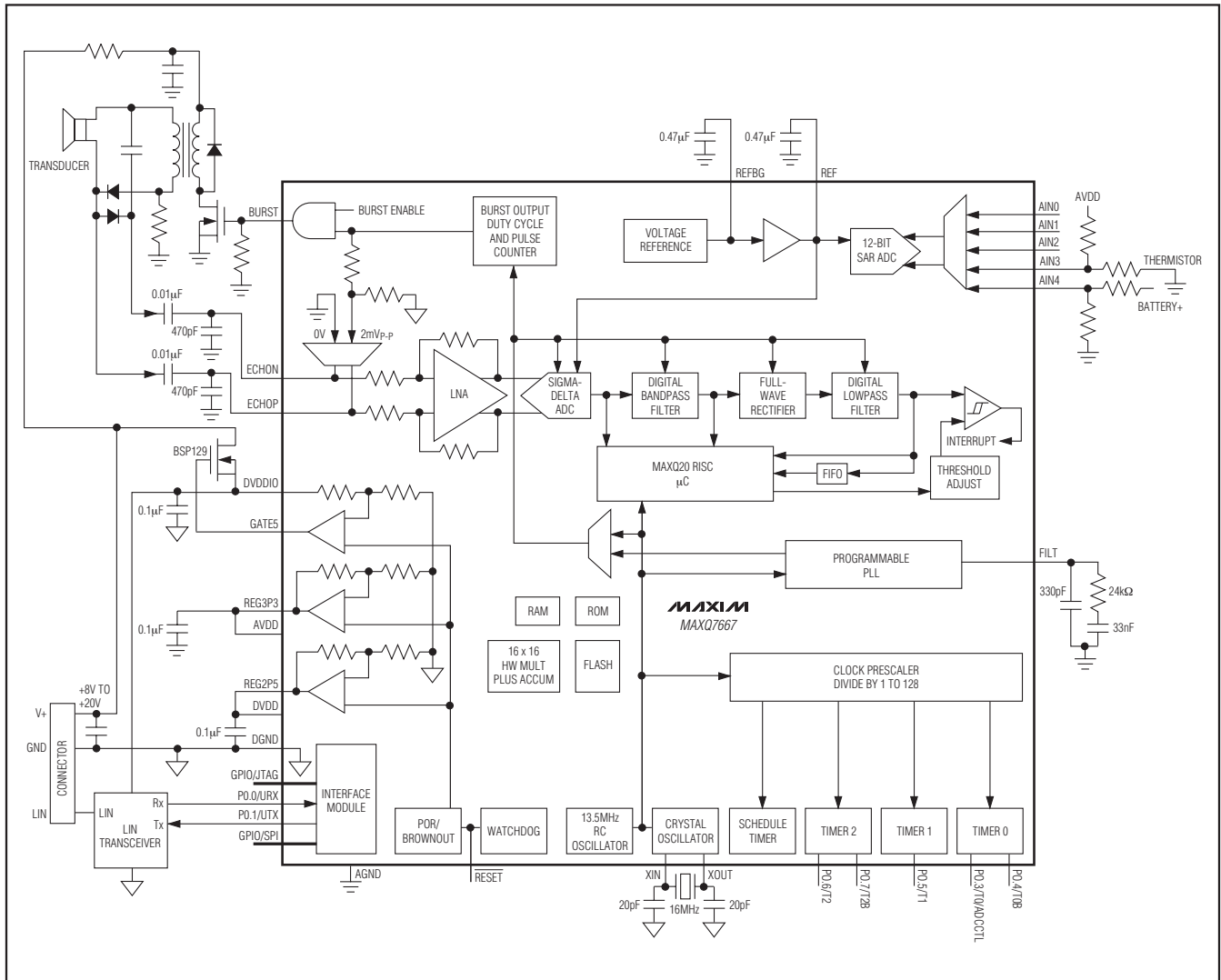

16-Bit, RISC, Microcontroller-Based, Ultrasonic Distance-Measuring System

MAXQ7667

Detailed Features

- ◆ Smart Analog Peripherals
 - Dedicated Ultrasonic Burst Generator
 - Echo Receiving Path
 - Low-Noise Amplifier
 - Time Variable Gain Amplifier
 - 16-Bit Sigma-Delta ADC
 - Digital Bandpass Filter
 - Full-Wave Rectifier and Digital Lowpass Filter
 - 8-Deep, 16-Bit Wide FIFO Simplifies Real-Time Processing
 - Magnitude Comparator
 - 5-Channel, 12-Bit SAR ADC with 250ksps Sampling Rate
 - Internal Bandgap Voltage Reference for the ADCs (Also Accepts External Voltage Reference)
- ◆ Timer/Digital I/O Peripherals
 - SPI Interface
 - Three 16-Bit (or Six 8-Bit) Programmable Type 2 Timers/Counters
 - 16-Bit Schedule Timer
 - Programmable Watchdog Timer
 - 16 General-Purpose Digital I/Os with Multipurpose Capability
- ◆ High-Performance, Low-Power, 16-Bit RISC Core
 - 1MHz–16MHz Operation, Approaching 1MIPS per 1MHz
 - Low Power (< 2.5mA/MIPS, DVDD = +2.5V)
 - 16-Bit Instruction Word, 16-Bit Data Bus
 - 33 Instructions (Most Require Only One Clock Cycle)
 - 16-Level Hardware Stack
 - Three Independent Data Pointers with Automatic Increment/Decrement
- ◆ Program and Data Memory
 - Internal 32KB Program Flash
 - Internal 4KB Data RAM
 - Internal 8KB Utility ROM
- ◆ Crystal/Clock Module
 - 1MHz–16MHz External Crystal Oscillator
 - 13.5MHz Internal RC Oscillator
 - External Clock Source Operation
- ◆ 16 x 16 Hardware Multiplier with 48-Bit Accumulator, Single Clock Cycle Operation
- ◆ Power-Management Module
 - Power-On Reset (POR)
 - Power-Supply Supervisor/Brownout Detection for All Supplies
 - On-Chip +5V, +3.3V, and +2.5V Regulators for Single Supply Operation
- ◆ JTAG Interface
 - Extensive Debug and Emulation Support
 - In-System Test Capability
 - Flash-Memory-Program Download
- ◆ UART
 - Synchronous and Asynchronous Transfers
 - Independent Baud-Rate Generator
 - 2-Wire Interface
 - Transmit and Receive FIFOs
- ◆ LIN
 - Supports LIN 1.3, LIN 2.0, and SAE J2602
 - Automatic Baud-Rate Detection and LIN Frame Synchronization
 - Up to 64 Bytes Frame Length
 - Automatic Calculation of Standard (LIN 1.3) and Enhanced (LIN 2.0) Checksums
- ◆ 7mm x 7mm, 48-Pin LQFP Package
- ◆ -40°C to +125°C Operating Temperature Range

16-Bit, RISC, Microcontroller-Based, Ultrasonic Distance-Measuring System

Detailed Description

The ultrasonic distance-measurement peripherals in the MAXQ7667 include a burst signal generator for acoustic transmission and mixed signal circuits for amplifying and digitizing echo signals ranging between 25kHz and 100kHz. The burst signal is a square wave with adjustable duty cycle and pulse count. The burst is derived either directly from the system clock or from a programmable PLL locked to the system clock. The MAXQ7667 effectively digitizes the echo signals received at the ECHOP and ECHON inputs using an LNA, sigma-delta ADC with variable analog gain amplifier, noise-limiting digital bandpass filter, digital full-wave rectifier, and a digital lowpass filter (see the *Typical Application Circuit/Functional Diagram*). The device detects echo signals at the burst frequency with amplitudes ranging from 10 μ V_{P-P} to 100mV_{P-P}. Echoes greater than 100mV_{P-P} and less than 2V_{P-P} are internally clipped but do not saturate the receiver. To optimize echo reception, the clock used for processing the echo locks to the burst frequency. The MAXQ7667's burst generator can generate higher frequencies, but the maximum usable frequency for the echo receive path is 100kHz. For applications requiring transducer frequencies above 100kHz, implement an external echo receive path. The SAR ADC can then digitize the filtered echo envelope.

An integrated 16-bit RISC μ C (MAXQ20) provides timing control, signal processing, and data I/O. The 16-bit Harvard architecture RISC core executes most instructions in a single clock cycle from instruction fetch to cycle completion. The MAXQ20 provides optimal performance for noise-sensitive analog applications.

The MAXQ7667 includes a 13.5MHz RC oscillator, external crystal oscillator, watchdog timer, schedule timer, three general-purpose Type 2 timers/counters, two 8-bit GPIO ports, SPI interface, JTAG interface, LIN capable UART interface, 12-bit SAR ADC with five multiplexed input channels, supply-voltage monitors, and a voltage reference for communication, diagnostics, and miscellaneous support.

Burst Controller

The MAXQ7667 provides a square-wave burst signal at the BURST output. Use the burst control to transmit an ultrasonic signal. Typical applications use the burst signal to switch an external transistor that drives a high-voltage transformer, which excites the transducer (see the *Typical Application Circuit/Functional Diagram*). Use software to configure the duty cycle, frequency, number of pulses, and drive current of the burst. See Section 17 of the *MAXQ7667 User's Guide*.

Derive the burst signal either directly from the system clock or from a programmable oscillator phase locked to the system clock (Figure 1). Using the system clock limits the burst frequency to one of 16 choices. Integer division of the system clock generates these 16 frequencies. The PLL allows a fractional division of the system clock. Any frequency within the PLL range is selectable to a resolution of 0.13% or better.

When using the internal PLL, connect external filter components (C1, R1, and C2) to FILT as shown in Figure 1. These components filter the analog voltage that controls the VCO in the PLL. The filter component values shown in the figure are suitable for the entire PLL frequency range.

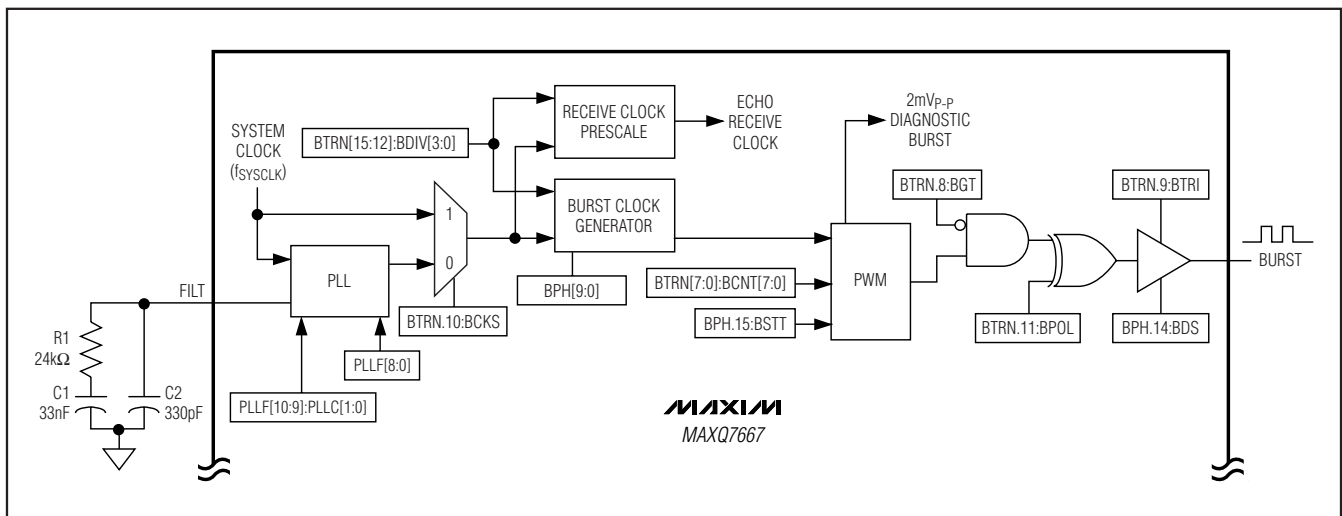

Figure 1. Burst Transmission Stage

16-Bit, RISC, Microcontroller-Based, Ultrasonic Distance-Measuring System

Echo Receive Path

Low-Noise Amplifier (LNA)

The LNA provides a 40V/V fixed gain to the input signal. The differential inputs of the LNA are ECHOP and ECHON. For proper biasing of the LNA, AC-couple the transducer or any external circuitry to ECHOP and ECHON. For a single-ended input signal, AC-couple the signal to ECHOP with a 0.01µF capacitor and connect ECHON to AGND through a 0.01µF capacitor placed as close as possible to the signal source. The outputs of the LNA connect to the inputs of a 16-bit sigma-delta ADC and can connect internally to the AIN0 and AIN1 inputs of the SAR ADC for external monitoring (Figure 2).

Diagnostic Signals

An analog multiplexer located at the input of the LNA selects one of three possible signals for processing by the echo receive path; the normal echo signal AC-coupled to the ECHOP and ECHON inputs, 0V signal, or a 2mV_{P-P} internally generated signal (Figure 2). The 2mV_{P-P} square-wave signal, with frequency and duty cycle matching the burst signal, allows the echo receive chain to process a simulated echo.

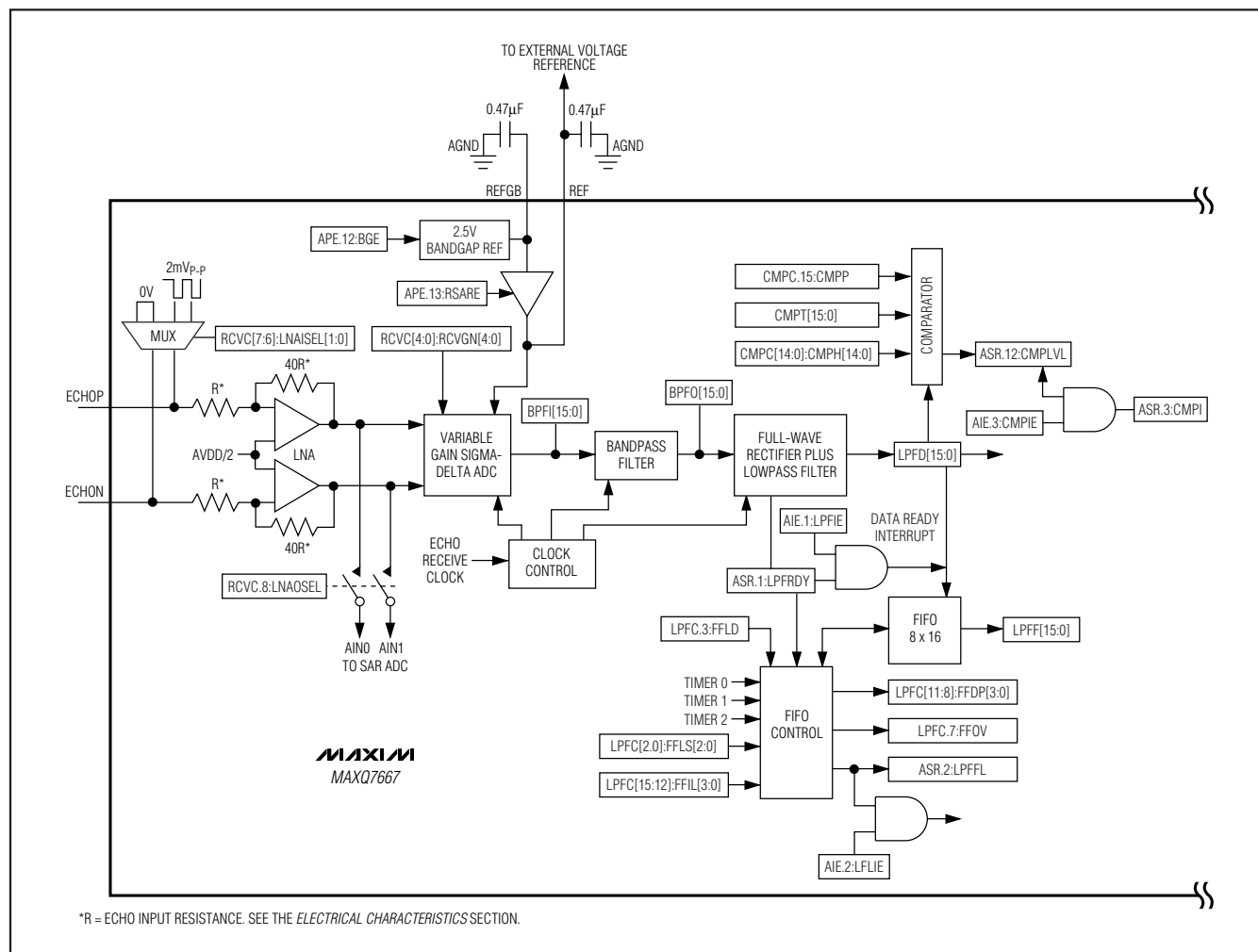

*R = ECHO INPUT RESISTANCE. SEE THE ELECTRICAL CHARACTERISTICS SECTION.

Figure 2. Echo Receive Path

16-Bit, RISC, Microcontroller-Based, Ultrasonic Distance-Measuring System

Sigma-Delta ADC

The MAXQ7667 features a 16-bit sigma-delta ADC with an analog gain adjustable from 38dB to 60dB (including the fixed LNA gain) with a maximum gain step of 12.5% (typical). Gain changes settle within one ADC conversion. Use software to create a virtual time variable gain amplifier. A digital bandpass and lowpass filters remove switching glitches and DC offset at the output of the ADC.

In a typical application, the software sets the gain to a low value when the burst is first sent and increases the gain as the time from when the burst was sent increases. As a result, strong echoes from nearby objects are processed without clipping while small signals from distant objects are processed with the maximum gain. The ADC samples the amplified echo signal from the LNA at 80 times the burst output frequency. The ADC provides conversion results at a data rate equal to 10 times the burst output frequency. The ADC conversion results also load to an 8-deep first-in-first-out (FIFO) at the native data rate or a separate time base without loading the CPU.

Digital Bandpass Filter

The digital bandpass filter has a center frequency that tracks the burst output frequency. The bandpass width is 14% of the center frequency. The bandpass filter provides the 16-bit output data at a data rate equal to 10 times the burst output frequency.

Full-Wave Rectifier

The full-wave rectifier detects the envelope of the digital bandwidth filter output to generate a DC output proportional to the peak-to-peak amplitude of the input signal. Full-wave rectification allows the digital lowpass filter to respond faster without excessive ripple.

Digital Lowpass Filter

The lowpass filter removes the ripple from the full-wave detector output. The output of the lowpass filter is available at a data rate equal to five times the burst output frequency. The corner frequency is 1/5 the burst frequency with approximately 40dB per decade rolloff. The 16-bit output data of the lowpass filter is stored in a FIFO register with a depth of eight samples. The MAXQ7667 allows data transfer from the lowpass filter

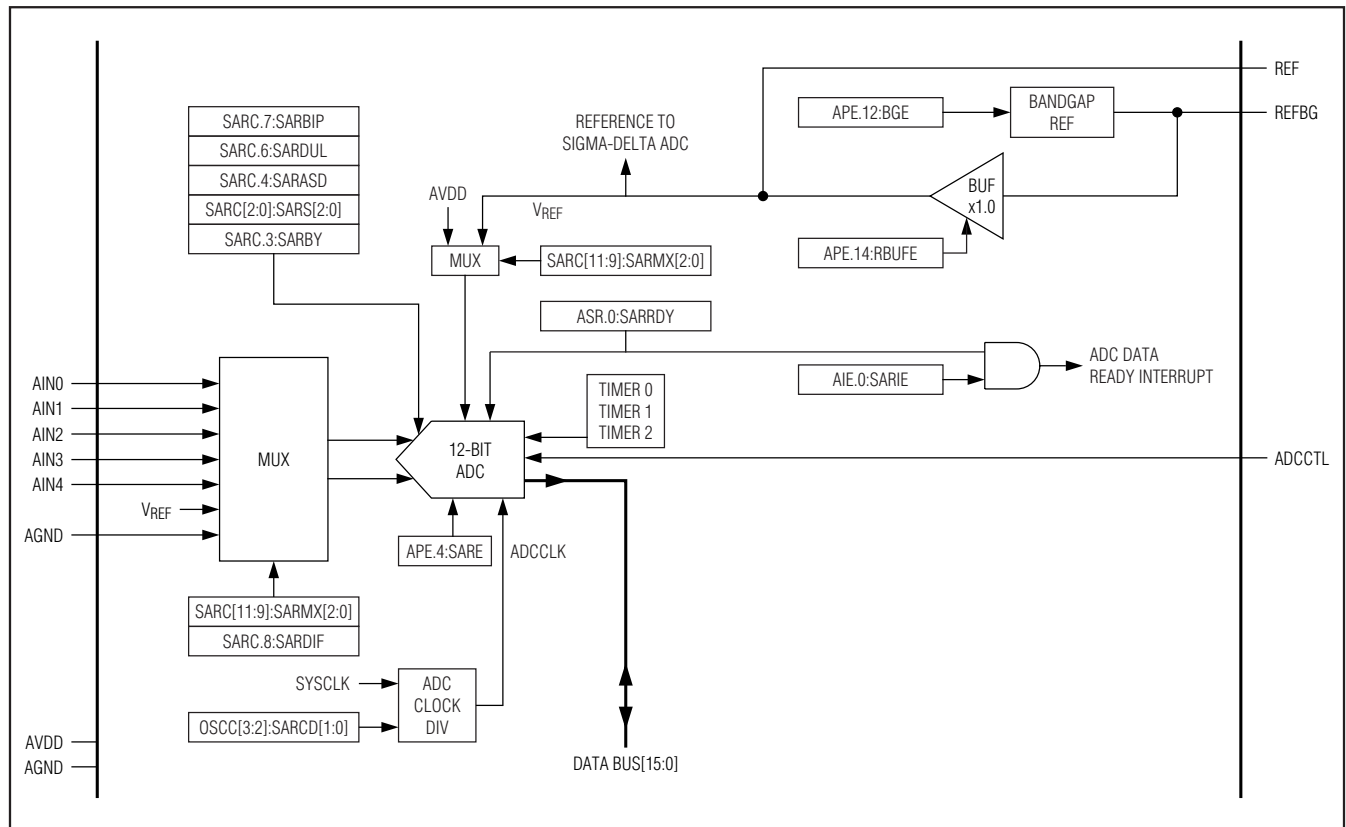

Figure 3. SAR ADC Block Diagram

16-Bit, RISC, Microcontroller-Based, Ultrasonic Distance-Measuring System

output to the FIFO automatically each time the lowpass filter output updates, through the control of one of the timer outputs, or through software. The device includes a FIFO depth counter with programmable interrupt levels and generates an interrupt if a FIFO overflow condition occurs. The output of the digital lowpass filter connects to a digital comparator that can generate an interrupt for a specified echo signal level.

Digital Comparator and Threshold Adjust

The digital comparator output asserts when the echo amplitude at the output of the digital lowpass filter crosses a given threshold. The comparator's threshold level, hysteresis, and interrupt polarity are programmable.

SAR ADC

The MAXQ7667 incorporates a 12-bit unbuffered SAR ADC with sample-and-hold and conversion rate up to 250ksps. The ADC allows measurements of tempera-

ture, battery voltage, or other parameters using five single-ended or two fully differential analog inputs (AIN0–AIN4). All of the analog inputs have a range of 0 to V_{REF} in unipolar mode and $\pm V_{REF}/2$ in bipolar mode.

The SAR ADC supports three different conversion start sources: timers, ADC control input (ADCCTL), and software write. The conversion start source triggers the ADC acquisition and conversion. The system clock provides the ADC clock frequency programmable to 1/2, 1/4, 1/8, or 1/16 of the system clock. Use internal bandgap reference, external reference, or AVDD for voltage reference of the SAR ADC. Figure 3 shows a simplified block diagram of the SAR ADC.

The output of the SAR ADC is straight binary in unipolar mode and two's complement in bipolar mode. Figures 4 and 5 show the ADC transfer functions in unipolar mode and bipolar mode.

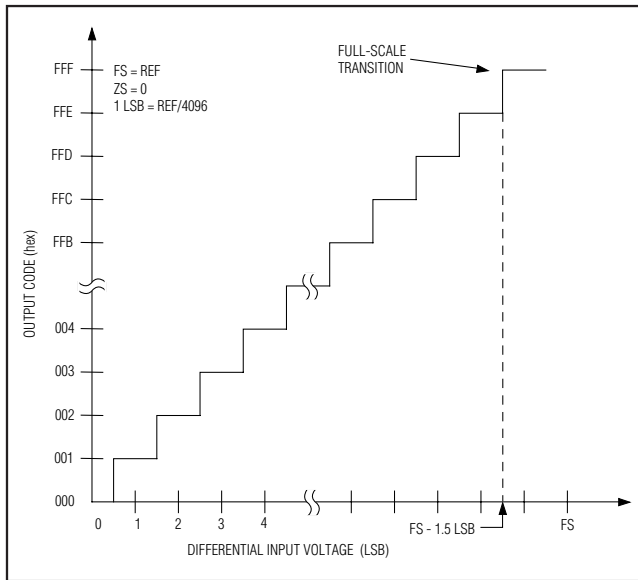

Figure 4. Unipolar Transfer Function

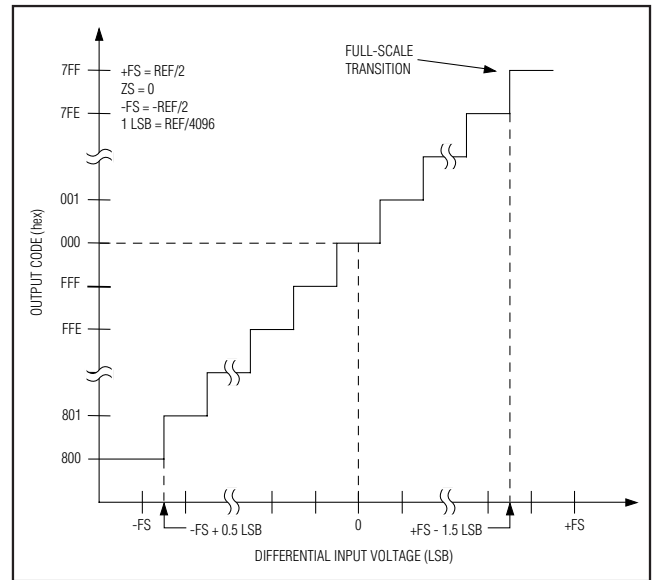

Figure 5. Bipolar Transfer Function

16-Bit, RISC, Microcontroller-Based, Ultrasonic Distance-Measuring System

SAR ADC Analog Input Track-and-Hold (T/H)

Figures 6 and 7 show the equivalent input circuit of the MAXQ7667 analog input architecture. During acquisition (track), a sampling capacitor charges to the positive input voltage at AIN0–AIN4 in single-ended mode or AIN0 and AIN2 in differential mode while a second sampling capacitor connects to AGND in single-ended mode or AIN1 and AIN3 in differential mode. The ADC conversion start source and the ADC dual mode selection bits control the T/H timing.

Voltage Reference

The MAXQ7667 supports three possible voltage reference sources for ADC conversion; 2.5V internal buffered bandgap reference, external source, and AVDD. The internal 2.5V bandgap reference has high initial accuracy and temperature coefficient of typically less than 100ppm/°C. When operating in internal reference mode, either the buffered output of the internal reference or AVDD connects to the SAR ADC while the buffered output of the internal reference connects to the sigma-delta ADC. When operating in external reference mode, an external source ranging between 1V and VAVDD applied at either the REF or REFBG inputs pro-

vides the reference to the SAR ADC and sigma-delta ADC. Bypass REF and REF to AGND with a 0.47µF capacitor for optimum performance. See Section 14 of the *MAXQ7667 User's Guide*.

Schedule Timer

The MAXQ7667's schedule timer provides general time-keeping and software synchronization to an external I/O. The schedule timer features include the following:

- 16-bit autoreload up-counter for the timer
- Programmable 16-bit alarm register
- Alarm interrupts
- Schedule timer incremented by a programmable system clock prescaler (1, 1/2, 1/4, 1/8, 1/16, 1/32, 1/64, 1/128)
- Schedule timer up-counter resettable through an external I/O pin, which allows synchronization of a schedule timer to an external event
- Wake-up alarm to pull the system clock from stop-mode to normal operation

Figure 8 shows a simplified block diagram of the schedule timer.

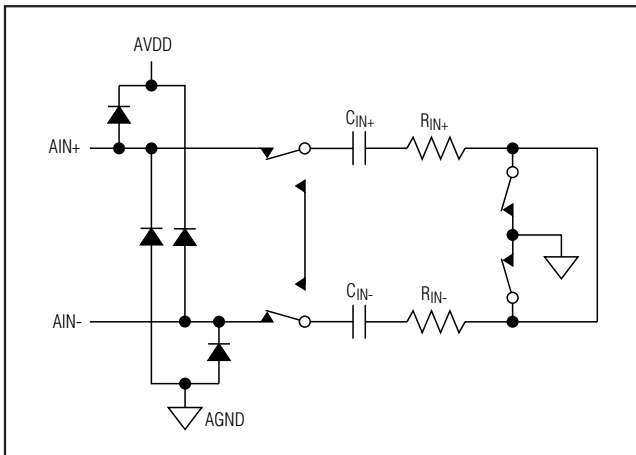

Figure 6. Equivalent Input Circuit (Track/Acquisition Mode)

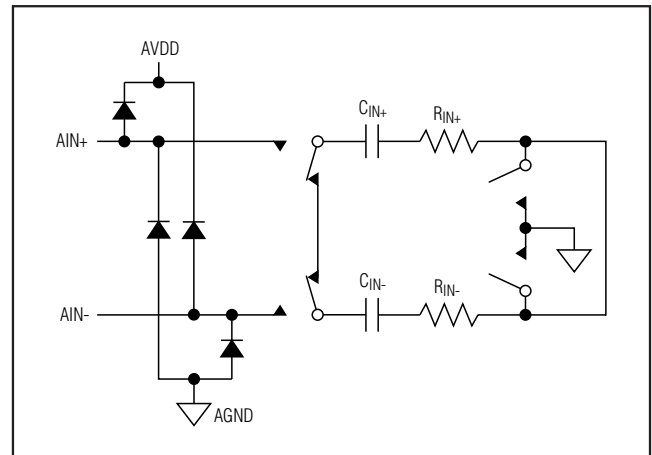

Figure 7. Equivalent Input Circuit (Hold/Conversion Mode)

16-Bit, RISC, Microcontroller-Based, Ultrasonic Distance-Measuring System

Type 2 Timers/Counters

The MAXQ7667 includes three 16-bit timers/counters with programmable I/O (Figure 9). Each timer is a Type 2 timer implemented in the MAXQ® family. The Type 2 timer is an autoreload 16-bit timer/counter offering the following functions:

- 8-bit/16-bit timer/counter
- Up/down autoreload
- Counter function of external pulse
- Capture
- Compare

Clock Sources

The MAXQ7667 oscillator module supplies the system clock for the μ C core and all of the peripheral modules. The high-frequency oscillator operates with a 1MHz to 16MHz crystal. Use the internal RC oscillator as the system clock for applications that do not require precise timing. See Section 15 of the *MAXQ7667 User's Guide*.

The MAXQ7667 supports the following master clock sources:

- Internal high-frequency oscillator drives an external 1MHz–16MHz crystal or ceramic resonator

- Internal, fast-starting, 13.5MHz RC oscillator (default oscillator at startup and in the event the external crystal fails)
- External 4MHz–16MHz clock input

Crystal Selection

The MAXQ7667 requires a crystal with the following specifications:

Frequency: 1MHz–16MHz

C_{LOAD}: 6pF (min)

Drive level: 5 μ W

Series resonance resistance: 30 Ω (max)

Note: Quartz crystal vendors often specify series resonance resistance (R1). Series resonance resistance is the resistance observed when the resonator is in the series resonant condition. When a resonator is used in the parallel resonant mode with an external load capacitance, as is the case with the MAXQ7667 oscillator circuit, the effective resistance at the loaded frequency of oscillation is:

$$R1 \times (1 + (CO/C_{LOAD}))^2$$

For typical shunt capacitance (CO) and load capacitance (C_{LOAD}) values, the effective resistance potentially exceeds R1 by a factor of 2.

16-Bit, RISC, Microcontroller-Based, Ultrasonic Distance-Measuring System

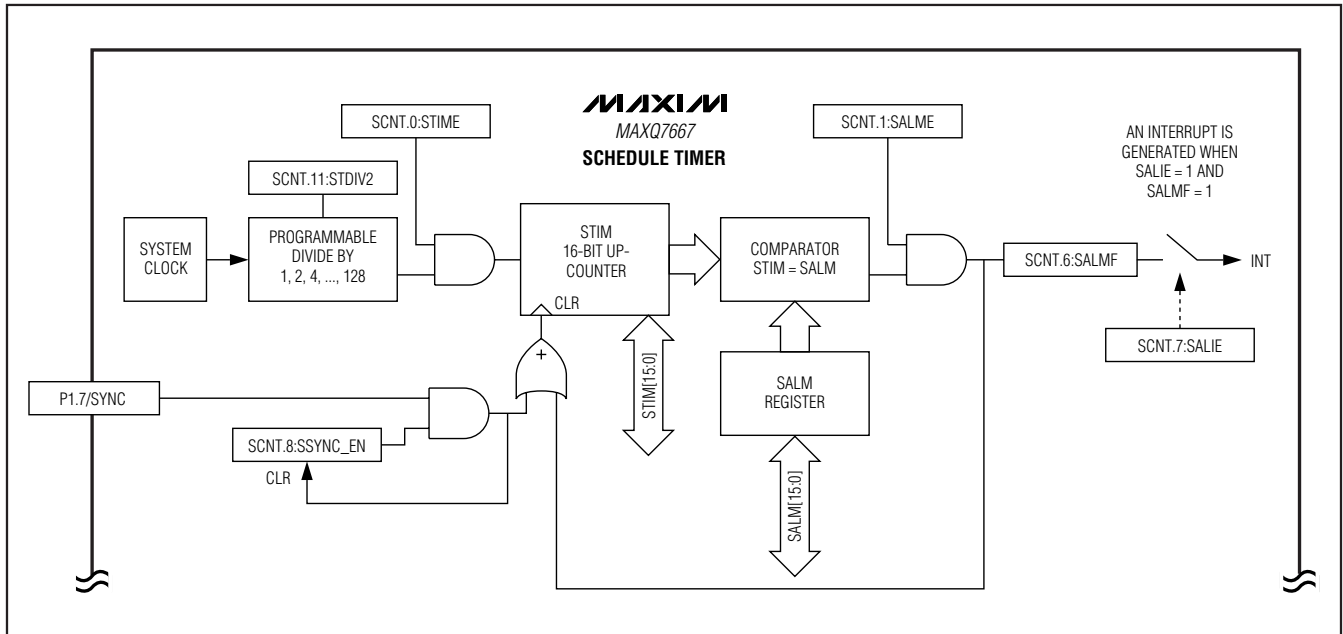

Figure 8. Schedule-Timer Module Block Diagram

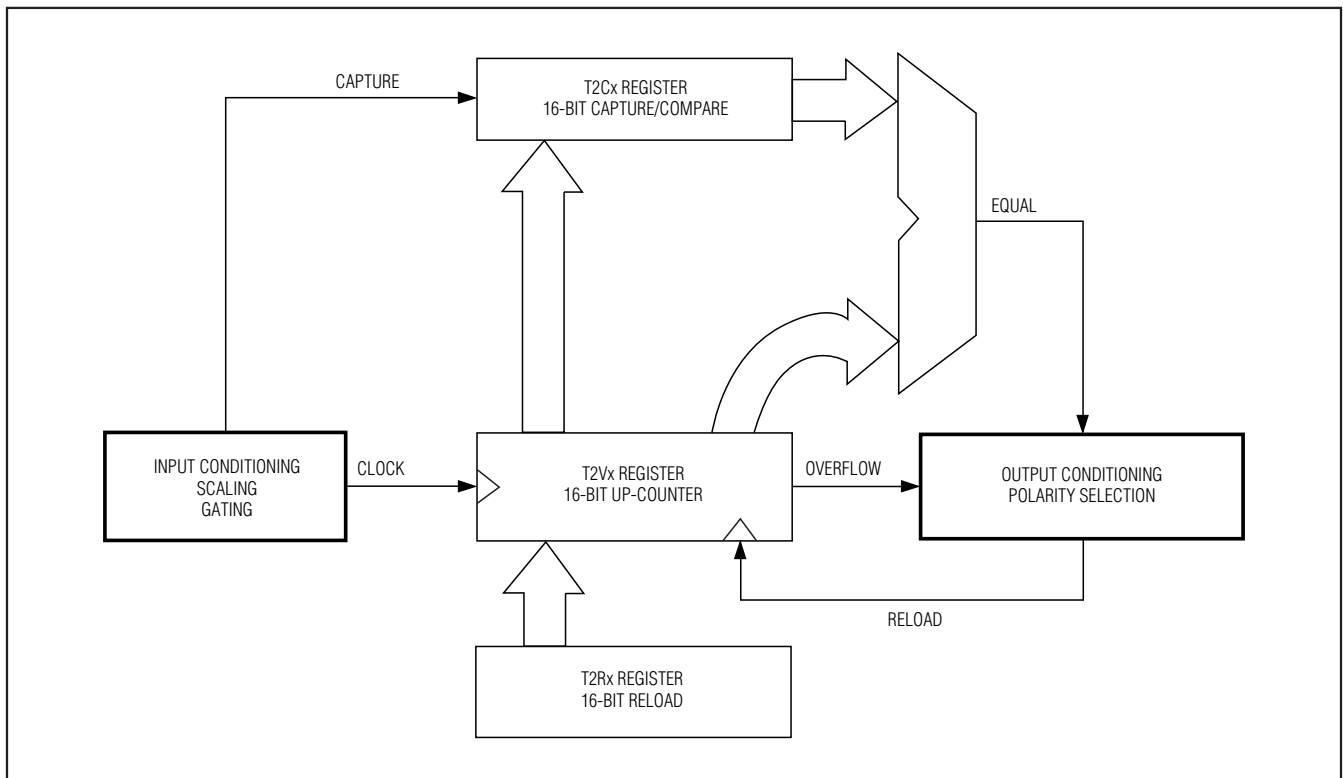

Figure 9. Type 2 Timer/Counter in 16-Bit Mode

16-Bit, RISC, Microcontroller-Based, Ultrasonic Distance-Measuring System

JTAG Interface

The joint test action group (JTAG) IEEE 1149.1 standard defines a unique method for in-circuit testing and programming. The MAXQ7667 conforms to this standard, implementing an external test access port (TAP) and internal TAP controller for communication with a JTAG bus master, such as an automatic test equipment (ATE) system. The MAXQ7667 JTAG interface does not allow boundary scan. For detailed information on the TAP and TAP controller, refer to IEEE Std 1149.1 "IEEE Standard Test Access Port and Boundary-Scan Architecture" on the IEEE website at www.standards.ieee.org.

The TAP controller communicates synchronously with the host system (bus master) through four digital I/Os: test mode select (TMS), test clock (TCK), test data input (TDI), and test data output (TDO). The internal TAP module consists of shift registers and a TAP controller (Figure 10). The shift registers serve as transmit and receive data buffers for a debugger. Maintain the maximum TCK clock frequency to below 1/8 the system clock frequency for proper operation.

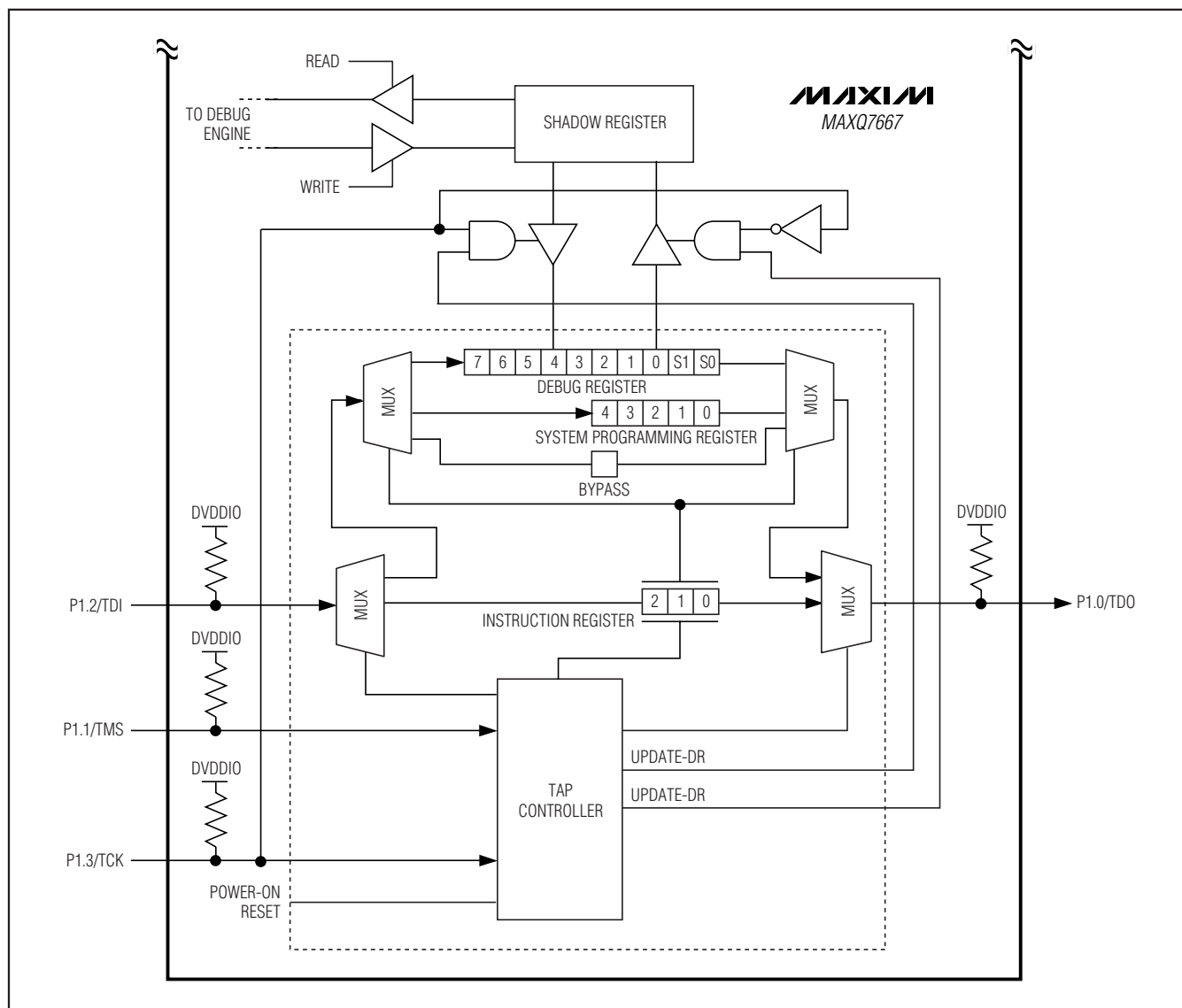

Figure 10. JTAG Interface Block Diagram

16-Bit, RISC, Microcontroller-Based, Ultrasonic Distance-Measuring System

The following four digital I/Os form the TAP interface:

- TDO—Serial output signal for test instruction and data. Data transitions on the falling edge of TCK. TDO idles high when inactive. TDO serially transfers internal data to the external host. Data transfers least significant bit first.
- TDI—Serial input signal for test instruction and data. Transition data on the rising edge of TCK. TDO pulls high when unconnected. TDI serially transfers data from the external host to the internal TAP module shift registers. Data transfers least significant bit first.
- TCK—Serial clock for the test logic. When TCK stops at 0, storage elements in the test logic must retain their data indefinitely. Force TCK high when inactive.
- TMS—Test mode selection. The rising edge of TCK samples the test signals at TMS. The TAP controller decodes the test signals at TMS to control the test operation. Force TMS high when inactive.

UART/LIN Interface

The MAXQ7667 includes a UART/LIN transceiver combination that supports communication speeds up to 2MBd. The LIN standard for example limits communication speed to 20kBd or less. Connect a LIN transceiver or other UART connections such as RS-232 and RS-485 directly to the MAXQ7667's 2-wire interface: URX and UTX. The MAXQ7667 operates as a LIN slave or LIN master device. The UART provides the programmable baud-rate generators to communicate effectively to or from the LIN transceiver. The device holds up to 8 bytes of data in each of the transmit and receive FIFOs. The following characteristics apply to the MAXQ7667 UART/LIN interface:

- Full-duplex operation for asynchronous data transfers up to 500kBd (system clock/32)
- Half-duplex operation for synchronous data transfers up to 2MBd (system clock/8)
- 8-deep receive and transmit FIFO with programmable interrupt for receive and transmit
- Independent baud-rate generator
- Programmable 9th data bit (commonly used for parity or address/data selection)—UART mode only
- Hardware support for LIN including break detection, autobaud, address identity filtering, checksum calculation, and block length checking

- Supports common RS-232 and LIN baud rates: 1000, 1200, 2400, 4800, 9600, 19,200, 20,000, 38,400, 57,600, and 115,200 with system clock = 16MHz.

SPI Interface

The MAXQ7667 supports 4-wire SPI interface communication with 8-bit or 16-bit data streams operating in either master mode or slave mode. The SPI interface allows synchronous half-duplex or full-duplex serial data transfers to a wide variety of external serial devices using MISO, MOSI, SS, and SCLK signals. Collision detection is provided when two or more masters attempt a data transfer at the same time. See Section 9 of the *MAXQ7667 User's Guide*.

General-Purpose Digital I/O Ports

Two 8-bit digital I/O ports (P0._ and P1._), with dedicated one or more alternative functions, are available as general-purpose I/Os (GPIOs) under the control of the integrated MAXQ20. Set each I/O within each port individually as an input or output. The GPIOs incorporate a Schmitt trigger receiver and a full CMOS output driver (Figure 13). Each GPIO configures as an input with pullup to DVDDIO at power-up. When programmed as an input, each I/O is configurable for high-impedance, weak pullup to DVDDIO or pulldown to DGND. When programmed as an output, writing to the port output register (PO) controls the output logic state. The outputs source or sink at least 1.6mA. Configure the drive strength for each I/O within each port to high or low using the pad drive strength register for optimum EMI performance. All the I/O ports have interrupt capability that wake up the device while in stop mode and have protection circuitry to DVDDIO and DGND.

Supply-Voltage Regulators

The MAXQ7667 requires three different power-supply voltages. DVDDIO, nominally +5V, allows interfacing to standard 5V logic on all the digital I/Os including the LIN/UART, JTAG, and SPI ports. DVDD, nominally +2.5V, powers all the high-speed digital circuits. AVDD, nominally 3.3V, powers the analog circuits.

External power supplies or internal voltage regulators provide each of the supply voltages. The internal voltage regulators provide 3.3V and 2.5V supplies from the 5V DVDDIO input. Obtain the 5V supply from a higher external voltage supply by using a few external components. The MAXQ7667 includes an internal error amplifier used to regulate the voltage on DVDDIO by driving the gate or base of an external pass transistor. Refer to the *MAXQ7667 User's Guide* for more details on the external components needed for 5V regulation.

16-Bit, RISC, Microcontroller-Based, Ultrasonic Distance-Measuring System

MAXQ7667

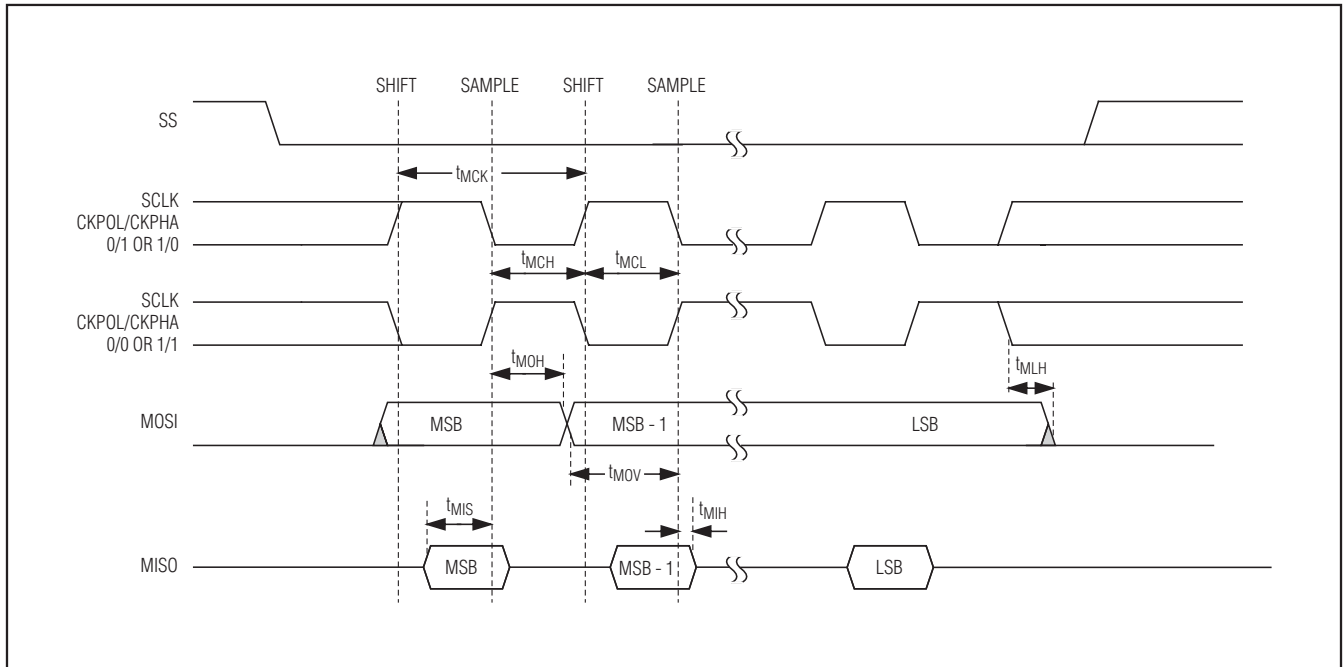

Figure 11. SPI Timing Diagram in Master Mode

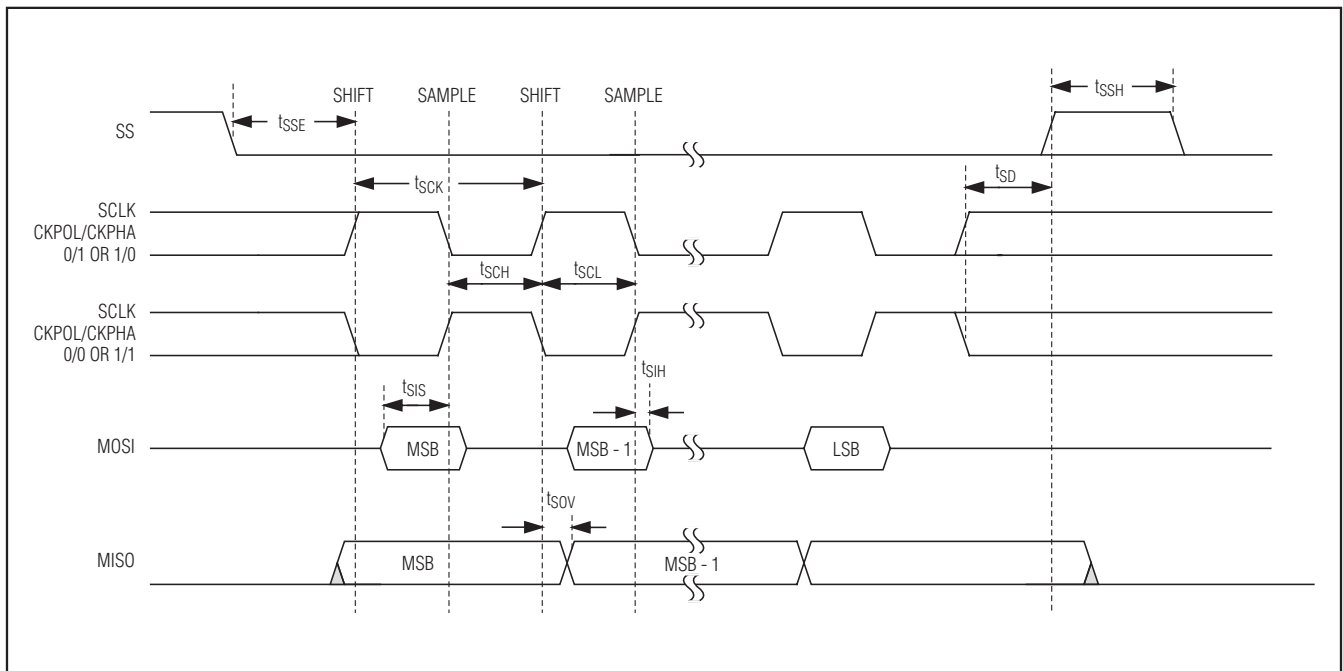

Figure 12. SPI Timing Diagram in Slave Mode

16-Bit, RISC, Microcontroller-Based, Ultrasonic Distance-Measuring System

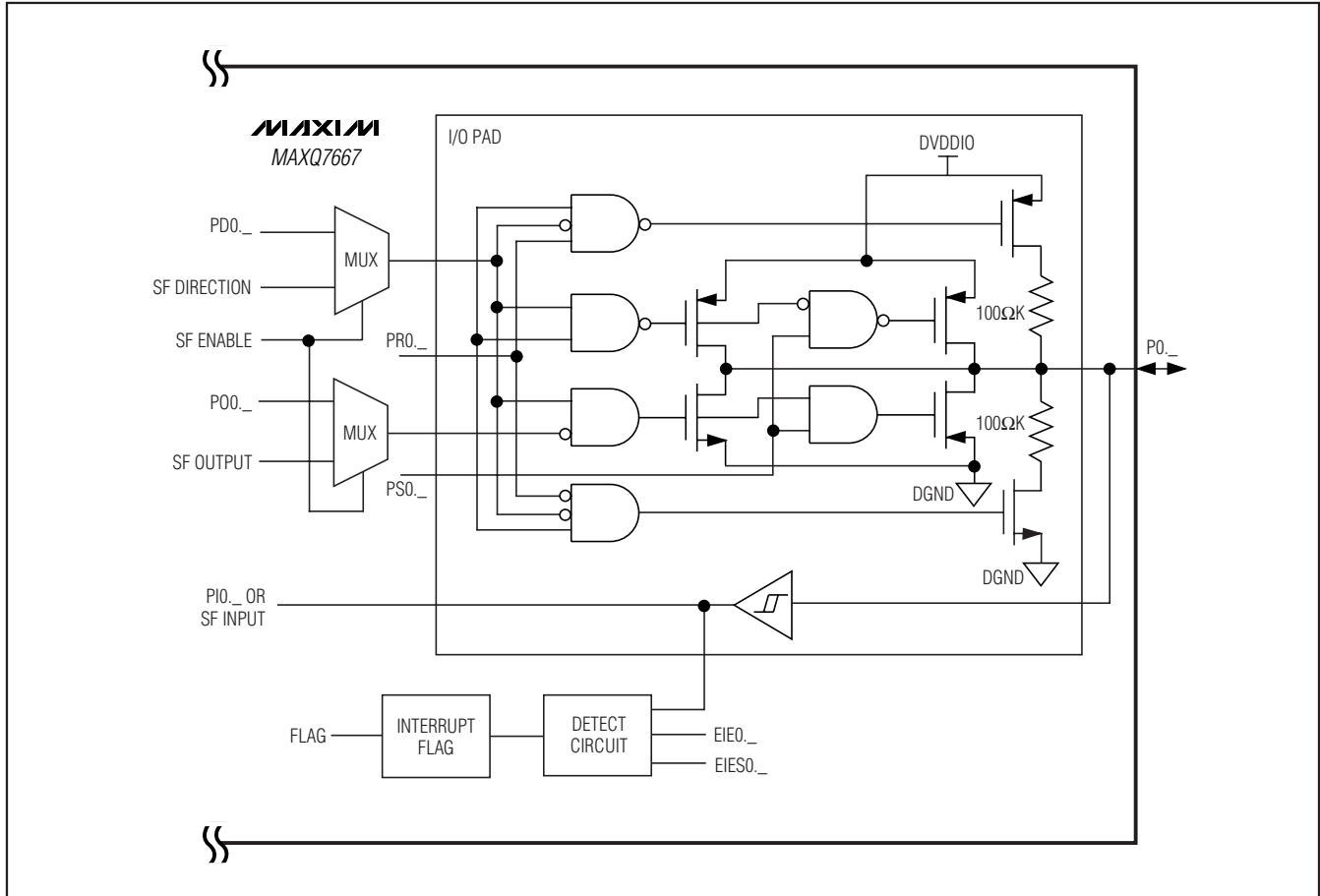

Figure 13. Port 0 Digital I/O Basic Circuitry. Port 1 Circuitry is the Same as Port 2.

Connect bypass capacitors at each power-supply input as close as possible to the device. Use a bypass capacitor less than $0.47\mu\text{F}$ on DVDDIO. For most applications, $0.1\mu\text{F}$ bypass capacitors are adequate.

Supply Brownout Monitor

Power supplies DVDD, AVDD, and DVDDIO each include a brownout monitor/supervisor that alerts the μC when their corresponding supply voltages drop below the interrupt threshold. Activate each brownout monitor independently using the corresponding brownout enable bits: VDBE, VIBE, and VABE.

Reset

In reset mode, no instruction execution occurs and all inputs/outputs return to their default states. Code execution resumes at address 8000h (in the utility ROM) once the reset condition is removed.

Four different sources reset the MAXQ7667: POR, watchdog timer reset, external reset, and internal system reset.

During normal operation, force $\overline{\text{RESET}}$ low for at least four system clock cycles for an external reset. Set the ROD bit in the SC register, while the SPE bit in the ICDF register is set, for an internal system reset. See Section 16 of the *MAXQ7667 User's Guide*.

Power-On Reset (POR)

The MAXQ7667 includes a DVDD voltage supervisor to control the μC POR. On power-up, internal circuitry pulls $\overline{\text{RESET}}$ low and resets all the internal registers. $\overline{\text{RESET}}$ is held low for the duration of the power-on delay after VDvDD rises above the DVDD reset threshold. The internal RC oscillator starts up and software execution begins at the reset vector location 8000h immediately after the device exits POR while $\overline{\text{RESET}}$ is

16-Bit, RISC, Microcontroller-Based, Ultrasonic Distance-Measuring System

not externally forced low. An internal POR flag indicates the source of a reset. Ramp up the DVDD supply at a minimum rate of 60mV/ms to keep the device in POR until DVDD fully settles.

Watchdog Timer

The primary function of the watchdog timer is to watch for stalled or stuck software. The watchdog timer performs a controlled system restart when the μ P fails to write to the watchdog timer register before a selectable timeout interval expires. The internal 13.5MHz RC oscillator drives the MAXQ7667's watchdog timer.

Figure 14 shows the watchdog timer functions as the source of both the watchdog interrupt and watchdog reset. The watchdog interrupt timeout period is programmable to 2^{12} , 2^{15} , 2^{18} , or 2^{21} cycles of the RC oscillator resulting in a nominal range of 273 μ s to 139.8ms. The watchdog reset timeout period is a fixed 512 RC clock cycles (34 μ s). When enabled, the watchdog generates an interrupt upon expiration; then, if not reset within 512 RC clock cycles, the watchdog asserts $\overline{\text{RESET}}$ low for eight RC clock cycles.

Hardware Multiplier/Accumulator

A hardware multiplier supports high-speed multiplications. The multiplier completes a 16-bit x 16-bit multiplication in a single clock cycle and contains a 48-bit accumulator. The multiplier is a peripheral that performs seven different multiplication operations:

- Unsigned 16-bit multiplication
- Unsigned 16-bit multiplication and accumulation
- Unsigned 16-bit multiplication and subtraction

- Signed 16-bit multiplication
- Signed 16-bit multiplication and negation
- Signed 16-bit multiplication and accumulation
- Signed 16-bit multiplication and subtraction

MAXQ Core Architecture

The MAXQ20 μ C is an accumulator-based Harvard memory architecture. Fetch and execution operations complete in one clock cycle without pipelining because the instruction contains both the op code and data. The μ C streamlines 16 million instructions per second (MIPS). Integrated 16-level hardware stack enables fast subroutine calling and task switching. Manipulate data quickly and efficiently with three internal data pointers. Multiple data pointers allow more than one function to access data memory without having to save and restore data pointers each time. The data pointers automatically increment or decrement following an operation, eliminating the need for software intervention.

Instruction Set

The instruction set consists of a total of 33 fixed-length 16-bit instructions that operate on registers and memory locations. The highly orthogonal instruction set allows arithmetic and logical operations to use any register along with the accumulator. System registers control functionality common to all MAXQ μ Cs, while peripheral registers control peripherals and functions specific to the MAXQ7667. All registers are subdivided into register modules.

The architecture is transport-triggered. Writes or reads from certain register locations potentially have side effects. These side effects form the basis for the higher level op codes defined by the assembler, such as ADDC, OR, JUMP, etc. The op codes are implemented as MOVE instructions between system registers. The assembler handles all the instruction encoding.

Memory Organization

In addition to the internal register space, the device incorporates several memory areas:

- 16Kwords of flash memory for program storage
- 2Kword of SRAM for storage of temporary variables
- 4Kwords utility ROM
- 16-level, 16-bit-wide hardware stack for storage of program return addresses and general-purpose use

Use the internal memory-management unit (MMU) to map data memory space into a predefined program memory segment for code execution from data memory. Use the MMU to map program memory space as data space for access to constant data stored in program

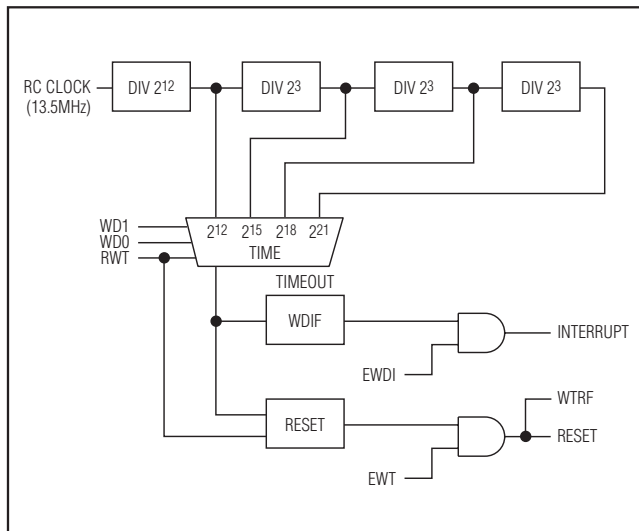

Figure 14. Watchdog Functional Diagram

16-Bit, RISC, Microcontroller-Based, Ultrasonic Distance-Measuring System

memory. Access physical memory segments (other than the stack and register memories) as either program memory or data memory, but not both at once.

By default, the memory is arranged in a Harvard architecture, with separate address spaces for program and data memory. The configuration of program and data space depends on the current execution location.

- When executing code from flash memory, access the SRAM and utility ROM in data space.
- When executing code from SRAM, access the flash memory and utility ROM in data space.
- When executing code from the utility ROM, access the flash memory and SRAM in data space.

Utility ROM (see Section 18 of the MAXQ7667 User's Guide)

The utility ROM is a 4K x 16 block of internal ROM memory that defaults to a starting address of 8000h. The utility ROM consists of subroutines called from application software. The subroutines include:

- In-system programming (bootloader) over the JTAG or UART interface
- In-circuit debug routines
- Test routines (internal memory tests, memory loader, etc.)
- User-callable routines for in-application flash programming and code space table lookup

Following any reset, execution begins in the utility ROM. The ROM software determines whether the program execution immediately jumps to the start of the user-application code (located at address 0000h) or to one of the special routines mentioned above. Call the routines within the utility ROM using the application software. Refer to the *MAXQ7667 User's Guide* for more information on the utility ROM contents.

Password protect in-system programming, in-application programming, and in-circuit debugging functions using a password-lock (PWL) bit. The PWL bit is implemented in the SC register. When the PWL bit is set to one (POR default), the password is required to access the utility ROM, including in-circuit debug and in-system programming routines that allow reading or writing of internal memory. When the PWL bit is cleared to zero, these utilities are fully accessible without the password. The password is automatically set to all ones following a mass erase.

Data Memory

The 2K x 16 internal data SRAM maps into either program or data space. The contents of the SRAM are maintained during stop mode and across non-POR resets, as long as DVDD remains within the operating voltage range.

A data memory cycle requires only one system clock period to support fast internal execution. This allows a complete read or write operation on SRAM in one clock cycle. The MMU handles data memory mapping and access control. Read or write to the data memory with word or byte-wide commands.

Stack Memory

The MAXQ7667 provides a 16 x 16 hardware stack to support subroutine calls and system interrupts. A 16-bit wide internal hardware stack provides storage for program return addresses and general-purpose use. The stack is used automatically by the processor when the CALL, RET, and RETI instructions are executed and interrupts serviced.

Register Set

Sets of registers control most functions. These registers provide a working space for memory operations as well as configuring and addressing peripheral registers on the device. Registers are divided into two major types; system registers and peripheral registers. The register set common to most MAXQ-based devices, also known as the system registers, includes the ALU, accumulator registers, data pointers, interrupt vectors and control, and stack pointer. The peripheral registers define additional functionality. Tables 1 and 3 show the MAXQ7667 register set.

Programming

Two different methods program the flash memory: in-system programming and in-application programming. Both methods afford great flexibility in system design as well as reduce the life-cycle cost of the embedded system. The MAXQ7667 password protects these features to prevent unauthorized access to code memory.

In-System Programming

An internal bootstrap loader reloads the device over a simple JTAG or UART interface allowing cost savings in system software upgrade. During power-up, the MAXQ7667 first checks for activity on the JTAG port. If no activity is present, the device checks if a password-protected program is present. If the password is set,

16-Bit, RISC, Microcontroller-Based, Ultrasonic Distance-Measuring System

the application code executes. The application codes initiate reprogramming. If the password is not set, the MAXQ7667 monitors the UART for an autobaud character (0x0D). If this character is received, the device sets its serial baud rate and initiates a boot loader procedure. If 0x0D is not received after five seconds, the device begins execution of the application code.

The following bootloader functions are supported:

- Load
- Dump
- CRC
- Verify
- Erase

In-Application Programming

The in-application programming feature allows the μC to modify its own flash program memory while simultaneously executing its application software. This allows on the fly software updates in mission-critical applications that cannot afford downtime. Erase and program the flash memory using the flash programming functions in the utility ROM. Refer to Section 18 of the *MAXQ7667 User's Guide* for a detailed description of the utility ROM functions.

Stop Mode

Power consumption reaches its minimum in stop mode (STOP = 1). In this mode, the external oscillator, internal RC oscillator, system clock, and all processing halts. Trigger an enabled external interrupt input or directly apply an external reset on $\overline{\text{RESET}}$ to exit stop mode. Upon exiting stop mode, the μC either waits for the external high-frequency crystal to complete its warmup period or starts execution immediately from its internal RC oscillator while the crystal warms up.

Interrupts

Multiple interrupt sources quickly respond to internal and external events. The MAXQ architecture uses a single interrupt vector (IV) and single interrupt-service routine (ISR) design. Enable interrupts globally,

individually, or by module. When an interrupt condition occurs, its individual flag is set even if the interrupt source is disabled at the local, module, or global level. Clear interrupt flags within the interrupt routine to avoid repeated false interrupts from the same source. Provide an adequate delay between the write to the flag and the RETI instruction using application software to allow time for the interrupt hardware to remove the internal interrupt condition. Asynchronous interrupt flags require a one-instruction delay and synchronous interrupt flags require a two-instruction delay.

When an enabled interrupt is detected, software jumps to a user-programmable interrupt vector location. The IV register defaults to 0000h on reset or power-up. Once software control transfers to the ISR, use the interrupt identification register (IIR) to determine if the source of the interrupt is a system register or peripheral register. The specified module identifies the specific interrupt source. The following interrupt sources are available:

- Watchdog interrupt
- External interrupts 0–7 on port 0 and port 1
- Timer 0 low compare, low overflow, capture/compare, and overflow interrupts
- Timer 1 low compare, low overflow, capture/compare, and overflow interrupts
- Timer 2 low compare, low overflow, and overflow interrupts
- Schedule timer alarm interrupt
- SPI data transfer complete, mode fault, write collision and receive overrun interrupts
- UART transmit, receive interrupts
- LIN mode master or slave interrupt
- SAR ADC data ready interrupt
- Echo envelope LPF output, FIFO full, and comparator interrupts
- Digital and I/O voltage brownout interrupts
- High-frequency oscillator failure interrupt

16-Bit, RISC, Microcontroller-Based, Ultrasonic Distance-Measuring System

Table 1. System Register Map

REGISTER INDEX	MODULE NAME (BASE SPECIFIER)						
	AP (8h)	A (9h)	PFX (Bh)	IP (Ch)	SP (Dh)	DPC (Eh)	DP (Fh)
0h	AP	A[0]	PFX[0]	IP	—	—	—
1h	APC	A[1]	PFX[1]	—	SP	—	—
2h	—	A[2]	PFX[2]	—	IV	—	—
3h	—	A[3]	PFX[3]	—	—	OFFS	DP[0]
4h	PSF	A[4]	PFX[4]	—	—	DPC	—
5h	IC	A[5]	PFX[5]	—	—	GR	—
6h	IMR	A[6]	PFX[6]	—	LC[0]	GRL	—
7h	—	A[7]	PFX[7]	—	LC[1]	BP	DP[1]
8h	SC	A[8]	—	—	—	GRS	—
9h	—	A[9]	—	—	—	GRH	—
Ah	—	A[10]	—	—	—	GRXL	—
Bh	<i>IIR</i>	A[11]	—	—	—	FP	—
Ch	—	A[12]	—	—	—	—	—
Dh	—	A[13]	—	—	—	—	—
Eh	CKCN	A[14]	—	—	—	—	—
Fh	WDCN	A[15]	—	—	—	—	—

Note: Registers in italics are read-only. Registers in bold are 16-bit wide.

16-Bit, RISC, Microcontroller-Based, Ultrasonic Distance-Measuring System

Table 2. System Register Bit and Reset Values

REGISTER	REGISTER BIT															
	15	14	13	12	11	10	9	8	7	6	5	4	3	2	1	0
AP								—	—	—	—	—	AP (4 Bits)			
APC								CLR	IDS	—	—	—	—	MOD2	MOD1	MOD0
PSF								Z	S	—	GPF1	GPF0	OV	C	E	E
IC								1	0	0	0	0	0	0	0	0
								—	—	CGDS	—	—	—	—	INS	IGE
IMR								IMS	—	IM5	IM4	IM3	IM2	IM1	IM0	IM0
SC								TAP	—	CDA1	CDA0	—	ROD	PWL	—	—
								1	0	0	0	0	0	0	s*	0
IIR								IIS	—	IIS	II4	II3	II2	II1	II0	II0
								0	0	0	0	0	0	0	0	0
CKGN								XTRC	—	RGMD	STOP	SWB	PMME	CD1	CD0	CD0
								s*	0	0	0	0	0	0	0	0
WDCN								POR	EWDI	WD1	WD0	WDIF	WTRF	EWT	RWT	RWT
								s*	s*	0	0	0	0	s*	s*	0
A[n] (0..15)	0	0	0	0	0	0	0	0	0	0	0	0	0	0	0	0
PFX[n] (0..7)	0	0	0	0	0	0	0	0	0	0	0	0	0	0	0	0
IP	1	0	0	0	0	0	0	0	0	0	0	0	0	0	0	0
	—	—	—	—	—	—	—	—	—	—	—	—	—	—	—	—
SP	0	0	0	0	0	0	0	0	0	0	0	0	1	1	1	1
IV	0	0	0	0	0	0	0	0	0	0	0	0	0	0	0	0
LC[0]	0	0	0	0	0	0	0	0	0	0	0	0	0	0	0	0
LC[1]	0	0	0	0	0	0	0	0	0	0	0	0	0	0	0	0

*Bits indicated by an "s" are only affected by a POR and not by other forms of reset. These bits are set to 0 after a POR. Refer to the MAXQ7667 User's Guide for more information.

16-Bit, RISC, Microcontroller-Based, Ultrasonic Distance-Measuring System

Table 2. System Register Bit and Reset Values (continued)

REGISTER	REGISTER BIT																
	15	14	13	12	11	10	9	8	7	6	5	4	3	2	1	0	
OFFS												OFFS (8 Bits)					
									0	0	0	0	0	0	0	0	
DPC												WBS2	WBS1	WBS0	SDPS1	SDPS0	
	0	0	0	0	0	0	0	0	0	0	0	1	1	1	0	0	
GR	GR15	GR14	GR13	GR12	GR11	GR10	GR9	GR8	GR7	GR6	GR5	GR4	GR3	GR2	GR1	GR0	
	0	0	0	0	0	0	0	0	0	0	0	0	0	0	0	0	
GRL									GRL7	GRL6	GRL5	GRL4	GRL3	GRL2	GRL1	GRL0	
									0	0	0	0	0	0	0	0	
BP	BP (16 Bits)																
GRS	0	0	0	0	0	0	0	0	0	0	0	0	0	0	0	0	
	GRS15	GRS14	GRS13	GRS12	GRS11	GRS10	GRS9	GRS8	GRS7	GRS6	GRS5	GRS4	GRS3	GRS2	GRS1	GRS0	
GRH	0	0	0	0	0	0	0										
									GR15	GR14	GR13	GR12	GR11	GR10	GR9	GR8	
GRXL	GRXL15	GRXL14	GRXL13	GRXL12	GRXL11	GRXL10	GRXL9	GRXL8	GRXL7	GRXL6	GRXL5	GRXL4	GRXL3	GRXL2	GRXL1	GRXL0	
	0	0	0	0	0	0	0	0	0	0	0	0	0	0	0	0	
FP	FP (16 Bits)																
DP[0]	0	0	0	0	0	0	0	0	0	0	0	0	0	0	0	0	
	DP[0] (16 Bits)																
DP[1]	0	0	0	0	0	0	0	0	0	0	0	0	0	0	0	0	
	DP[1] (16 Bits)																

*Bits indicated by an "s" are only affected by a POR and not by other forms of reset. These bits are set to 0 after a POR. Refer to the MAXQ7667 User's Guide for more information.

16-Bit, RISC, Microcontroller-Based, Ultrasonic Distance-Measuring System

MAXQ7667

Table 3. Peripheral Register Map

REGISTER INDEX	MODULE NAME (BASE SPECIFIER)					
	M0 (0h)	M1 (1h)	M2 (2h)	M3 (3h)	M4 (4h)	M5 (5h)
0h	PO0	MCNT	T2CNA0	T2CNA2	—	BPH
1h	PO1	MA	T2H0	T2H2	—	BTRN
2h	—	MB	T2RH0	T2RH2	—	SARC
3h	EIF0	MC2	T2CH0	T2CH2	—	RCVC
4h	EIF1	MC1	T2CNA1	—	—	PLL
5h	—	MC0	T2H1	CNT1	—	AIE
6h	—	SPIB	T2RH1	SCON	—	CMPC
7h	—	SPICN	T2CH1	SBUF	—	CMPT
8h	PI0	SPICF	T2CNB0	T2CNB2	—	ASR
9h	PI1	SPICK	T2V0	T2V2	—	SARD
Ah	—	—	T2R0	T2R2	—	LPFC
Bh	EIE0	—	T2C0	T2C2	—	OSCC
Ch	EIE1	MC1R	T2CNB1	FSTAT	—	BPFI
Dh	—	MC0R	T2V1	ERRR	—	BPFO
Eh	—	SCNT	T2R1	CHKSUM	—	LPFD
Fh	—	STIM	T2C1	ISVEC	—	LPFF
10h	PDO	SALM	T2CFG0	T2CFG2	—	APE
11h	PD1	FPCTL	T2CFG1	STA0	—	—
12h	—	—	—	SMD	—	FGAIN
13h	EIES0	—	—	FCON	—	B1COEF
14h	EIES1	—	—	CNT0	—	B2COEF
15h	—	—	—	CNT2	—	B3COEF
16h	—	—	—	IDFB	—	A2A
17h	—	RCTRM	—	SADDR	—	A2B
18h	PS0	—	ICDT0	SADEN	—	—
19h	PS1	—	ICDT1	BT	—	A2D
1Ah	—	—	ICDC	TMR	—	—
1Bh	PR0	—	ICDF	—	—	A3A
1Ch	PR1	ID0	ICDB	—	—	A3B
1Dh	—	ID1	ICDA	—	—	—
1Eh	—	—	ICDD	—	—	A3D
1Fh	—	—	—	—	—	—

16-Bit, RISC, Microcontroller-Based, Ultrasonic Distance-Measuring System

Table 4. Peripheral Register Bit Functions and Reset Values

REGISTER	15	14	13	12	11	10	9	8	REGISTER BIT								1	0
									7	6	5	4	3	2				
PO0	0	0	0	0	0	0	0	0	PO07	PO06	PO05	PO04	PO03	PO02	PO01	PO00		
PO1	0	0	0	0	0	0	0	0	PO17	PO16	PO15	PO14	PO13	PO12	PO11	PO10		
EiF0	0	0	0	0	0	0	0	0	IE7	IE6	IE5	IE4	IE3	IE2	IE1	IE0		
EiF1	0	0	0	0	0	0	0	0	IE7	IE6	IE5	IE4	IE3	IE2	IE1	IE0		
PI0	0	0	0	0	0	0	0	0	PI07	PI06	PI05	PI04	PI03	PI02	PI01	PI00		
PI1	0	0	0	0	0	0	0	0	ST	ST	ST	ST	ST	ST	ST	ST		
EiE0	0	0	0	0	0	0	0	0	EX7	EX6	EX5	EX4	EX3	EX2	EX1	EX0		
EiE1	0	0	0	0	0	0	0	0	EX7	EX6	EX5	EX4	EX3	EX2	EX1	EX0		
PD0	0	0	0	0	0	0	0	0	PD07	PD06	PD05	PD04	PD03	PD02	PD01	PD00		
PD1	0	0	0	0	0	0	0	0	PD17	PD16	PD15	PD14	PD13	PD12	PD11	PD10		
EiES0	0	0	0	0	0	0	0	0	IT7	IT6	IT5	IT4	IT3	IT2	IT1	IT0		
EiES1	0	0	0	0	0	0	0	0	IT7	IT6	IT5	IT4	IT3	IT2	IT1	IT0		
PS0	0	0	0	0	0	0	0	0	PS07	PS06	PS05	PS04	PS03	PS02	PS01	PS00		
PS1	0	0	0	0	0	0	0	0	PS17	PS16	PS15	PS14	PS13	PS12	PS11	PS10		
PR0	0	0	0	0	0	0	0	0	PR07	PR06	PR05	PR04	PR03	PR02	PR01	PR00		
PR1	0	0	0	0	0	0	0	0	PR17	PR16	PR15	PR14	PR13	PR12	PR11	PR10		
MCNT	0	0	0	0	0	0	0	0	OF	MCW	CLD	SOU	OPCS	MSUB	MMAC	SUS		
MA	MA15	MA14	MA13	MA12	MA11	MA10	MA9	MA8	MA7	MA6	MA5	MA4	MA3	MA2	MA1	MA0		
MB	MB15	MB14	MB13	MB12	MB11	MB10	MB9	MB8	MB7	MB6	MB5	MB4	MB3	MB2	MB1	MB0		
MC2	MC215	MC214	MC213	MC212	MC211	MC210	MC29	MC28	MC27	MC26	MC25	MC24	MC23	MC22	MC21	MC20		
MC1	MC115	MC114	MC113	MC112	MC111	MC110	MC19	MC18	MC17	MC16	MC15	MC14	MC13	MC12	MC11	MC10		
MC0	MC015	MC014	MC013	MC012	MC011	MC010	MC09	MC08	MC07	MC06	MC05	MC04	MC03	MC02	MC01	MC00		
SPIB	SPIB15	SPIB14	SPIB13	SPIB12	SPIB11	SPIB10	SPIB9	SPIB8	SPIB7	SPIB6	SPIB5	SPIB4	SPIB3	SPIB2	SPIB1	SPIB0		
SPICN	0	0	0	0	0	0	0	0	STBY	SPIC	FOVR	WCOL	MODF	MODFE	MSTM	SPIEN		
SPICF	0	0	0	0	0	0	0	0	ESPII	SAS	—	—	—	CHR	CKPHA	CKPOL		
SPICK	0	0	0	0	0	0	0	0	SPICK7	SPICK6	SPICK5	SPICK4	SPICK3	SPICK2	SPICK1	SPICK0		
FCNTL	0	0	0	0	0	0	0	0	FBUSY	—	—	—	—	FC2	FC1	FC0		
MC1R	MC1R15	MC1R14	MC1R13	MC1R12	MC1R11	MC1R10	MC1R9	MC1R8	MC1R7	MC1R6	MC1R5	MC1R4	MC1R3	MC1R2	MC1R1	MC1R0		
MC0R	MC0R15	MC0R14	MC0R13	MC0R12	MC0R11	MC0R10	MC0R9	MC0R8	MC0R7	MC0R6	MC0R5	MC0R4	MC0R3	MC0R2	MC0R1	MC0R0		

16-Bit, RISC, Microcontroller-Based, Ultrasonic Distance-Measuring System

MAXQ7667

Table 4. Peripheral Register Bit Functions and Reset Values (continued)

REGISTER	REGISTER BIT															
	15	14	13	12	11	10	9	8	7	6	5	4	3	2	1	0
SCNT	—	—	—	—	—	—	—	SSYNC_EN	SALIE	SALMF	—	—	—	—	SALME	STIME
STIM	STIM15	STIM14	STIM13	STIM12	STIM11	STIM10	STIM9	STIM8	STIM7	STIM6	STIM5	STIM4	STIM3	STIM2	STIM1	STIM0
SALM	SALM15	SALM14	SALM13	SALM12	SALM11	SALM10	SALM9	SALM8	SALM7	SALM6	SALM5	SALM4	SALM3	SALM2	SALM1	SALM0
FPCNTL	—	—	—	—	—	—	—	—	—	—	—	—	—	—	—	DFPMG
RCTRM	—	—	—	—	—	—	—	RCTRM8	RCTRM7	RCTRM6	RCTRM5	RCTRM4	RCTRM3	RCTRM2	RCTRM1	RCTRM0
ID0	ID015	ID014	ID013	ID012	ID011	ID010	ID09	ID08	ID07	ID06	ID05	ID04	ID03	ID02	ID01	ID00
ID1	ID115	ID114	ID113	ID112	ID111	ID110	ID19	ID18	ID17	ID16	ID15	ID14	ID13	ID12	ID11	ID10
T2CNA0	—	—	—	—	—	—	—	—	ET2	T2OE0	T2POL0	TR2L	TR2	CPRL2	SS2	G2EN
T2H0	—	—	—	—	—	—	—	—	T2H07	T2H06	T2H05	T2H04	T2H03	T2H02	T2H01	T2H00
T2RH0	—	—	—	—	—	—	—	—	T2RH07	T2RH06	T2RH05	T2RH04	T2RH03	T2RH02	T2RH01	T2RH00
T2CH0	—	—	—	—	—	—	—	—	T2CH07	T2CH06	T2CH05	T2CH04	T2CH03	T2CH02	T2CH01	T2CH00
T2CNA1	—	—	—	—	—	—	—	—	ET2	T2OE0	T2POL0	TR2L	TR2	CPRL2	SS2	G2EN
T2H1	—	—	—	—	—	—	—	—	T2H17	T2H16	T2H15	T2H14	T2H13	T2H12	T2H11	T2H10
T2RH1	—	—	—	—	—	—	—	—	T2RH17	T2RH16	T2RH15	T2RH14	T2RH13	T2RH12	T2RH11	T2RH10
T2CH1	—	—	—	—	—	—	—	—	T2CH17	T2CH16	T2CH15	T2CH14	T2CH13	T2CH12	T2CH11	T2CH10
T2CNB0	—	—	—	—	—	—	—	—	ET2L	T2OE1	T2POL1	—	TF2	TF2L	TCC2	TC2L
T2V0	T2V015	T2V014	T2V013	T2V012	T2V011	T2V010	T2V09	T2V08	T2V07	T2V06	T2V05	T2V04	T2V03	T2V02	T2V01	T2V00
T2R0	T2R015	T2R014	T2R013	T2R012	T2R011	T2R010	T2R09	T2R08	T2R07	T2R06	T2R05	T2R04	T2R03	T2R02	T2R01	T2R00
T2C0	T2C015	T2C014	T2C013	T2C012	T2C011	T2C010	T2C09	T2C08	T2C07	T2C06	T2C05	T2C04	T2C03	T2C02	T2C01	T2C00
T2CNB1	—	—	—	—	—	—	—	—	ET2L	T2OE1	T2POL1	—	TF2	TF2L	TCC2	TC2L
T2V1	T2V115	T2V114	T2V113	T2V112	T2V111	T2V110	T2V19	T2V18	T2V17	T2V16	T2V15	T2V14	T2V13	T2V12	T2V11	T2V10
T2R1	T2R115	T2R114	T2R113	T2R112	T2R111	T2R110	T2R19	T2R18	T2R17	T2R16	T2R15	T2R14	T2R13	T2R12	T2R11	T2R10
T2C1	T2C115	T2C114	T2C113	T2C112	T2C111	T2C110	T2C19	T2C18	T2C17	T2C16	T2C15	T2C14	T2C13	T2C12	T2C11	T2C10
T2CFG0	—	—	—	—	—	—	—	—	T2C1	T2DM2	T2DIV1	T2DIV0	T2MD	CCF1	CCF0	C7/2
T2CFG1	—	—	—	—	—	—	—	—	T2C1	T2DM2	T2DIV1	T2DIV0	T2MD	CCF1	CCF0	C7/2
ICD0	ICD015	ICD014	ICD013	ICD012	ICD011	ICD010	ICD09	ICD08	ICD07	ICD06	ICD05	ICD04	ICD03	ICD02	ICD01	ICD00
ICD1	ICD115	ICD114	ICD113	ICD112	ICD111	ICD110	ICD19	ICD18	ICD17	ICD16	ICD15	ICD14	ICD13	ICD12	ICD11	ICD10
ICDC	—	—	—	—	—	—	—	—	DME	—	REG	—	CMD3	CMD2	CMD1	CMD0
	0	0	0	0	0	0	0	0	DW	0	DW	0	DW	DW	DW	DW

16-Bit, RISC, Microcontroller-Based, Ultrasonic Distance-Measuring System

Table 4. Peripheral Register Bit Functions and Reset Values (continued)

REGISTER	15	14	13	12	11	10	9	8	7	6	5	4	3	2	1	0
ICDF	0	0	0	0	0	0	0	0	0	0	0	0	0	0	0	TXC
ICDB	0	0	0	0	0	0	0	0	0	0	0	0	0	0	0	0
ICDA	ICDA15	ICDA14	ICDA13	ICDA12	ICDA11	ICDA10	ICDA9	ICDA8	ICDA7	ICDA6	ICDA5	ICDA4	ICDA3	ICDA2	ICDA1	ICDA0
ICDD	ICDD15	ICDD14	ICDD13	ICDD12	ICDD11	ICDD10	ICDD9	ICDD8	ICDD7	ICDD6	ICDD5	ICDD4	ICDD3	ICDD2	ICDD1	ICDD0
T2CNA2	0	0	0	0	0	0	0	0	ET2	T2OE0	T2POL0	TR2L	TR2	CPRL2	SS2	G2EN
T2H2	0	0	0	0	0	0	0	0	T2H27	T2H26	T2H25	T2H24	T2H23	T2H22	T2H21	T2H20
T2RH2	0	0	0	0	0	0	0	0	T2RH27	T2RH26	T2RH25	T2RH24	T2RH23	T2RH22	T2RH21	T2RH20
T2CH2	0	0	0	0	0	0	0	0	T2CH27	T2CH26	T2CH25	T2CH24	T2CH23	T2CH22	T2CH21	T2CH20
CNT1	0	0	0	0	0	0	0	0	RTN	OK	FL5	FL4	FL3	FL2	FL1	FL0
SCON	0	0	0	0	0	0	0	0	SMO/FE	SM1	SM2	REN	TB8	RB8	TI	RI
SBUF	0	0	0	0	0	0	0	0	SBUF7	SBUF6	SBUF5	SBUF4	SBUF3	SBUF2	SBUF1	SBUF0
T2CNB2	0	0	0	0	0	0	0	0	ET2L	T2OE1	T2POL1	—	TF2	TF2L	TCC2	TC2L
T2V2	T2V215	T2V214	T2V213	T2V212	T2V211	T2V210	T2V29	T2V28	T2V27	T2V26	T2V25	T2V24	T2V23	T2V22	T2V21	T2V20
T2R2	T2R215	T2R214	T2R213	T2R212	T2R211	T2R210	T2R29	T2R28	T2R27	T2R26	T2R25	T2R24	T2R23	T2R22	T2R21	T2R20
T2C2	T2C215	T2C214	T2C213	T2C212	T2C211	T2C210	T2C29	T2C28	T2C27	T2C26	T2C25	T2C24	T2C23	T2C22	T2C21	T2C20
FSTAT	0	0	0	0	0	0	0	0	—	—	TFE	TFAE	TFE	RFF	RFAF	RFE
ERRR	0	0	0	0	0	0	0	0	—	OTE	DME	OKE	P1	PIE	P0	POE
CHKSUM	CHKSUM15	CHKSUM14	CHKSUM13	CHKSUM12	CHKSUM11	CHKSUM10	CHKSUM9	CHKSUM8	CHKSUM7	CHKSUM6	CHKSUM5	CHKSUM4	CHKSUM3	CHKSUM2	CHKSUM1	CHKSUM0
ISVEC	0	0	0	0	0	0	0	0	0	0	0	0	ISVEC3	ISVEC2	ISVEC1	ISVECO
T2CFG2	0	0	0	0	0	0	0	0	T2C1	T2DIV2	T2DIV1	T2DIV0	T2MD	CCF1	CCF0	CT2
STA0	0	0	0	0	0	0	0	0	—	—	—	—	—	—	INP	BUSY
SMD	0	0	0	0	0	0	0	0	EIR	OFS	—	—	—	IE	SMOD	FEDE
FCON	0	0	0	0	0	0	0	0	FTF	FRF	TXFT1	TXFT0	RXFT1	RXFT0	OE	FEN
CNT0	0	0	0	0	0	0	0	0	WU	FP1	FF0	INE	AUT	INIT	LUN1	LUN0
CNT2	0	0	0	0	0	0	0	0	—	—	—	DMIS	PM	HDO	FBS	BTH
IDFB	0	0	IDFBH5	IDFBH4	IDFBH3	IDFBH2	IDFBH1	IDFBH0	—	—	IDFBL5	IDFBL4	IDFBL3	IDFBL2	IDFBL1	IDFBL0
SADDR	0	0	0	0	0	0	0	0	SADDR7	SADDR6	SADDR5	SADDR4	SADDR3	SADDR2	SADDR1	SADDR0
SADEN	0	0	0	0	0	0	0	0	SADEN7	SADEN6	SADEN5	SADEN4	SADEN3	SADEN2	SADEN1	SADEN0

16-Bit, RISC, Microcontroller-Based, Ultrasonic Distance-Measuring System

MAXQ7667

Table 4. Peripheral Register Bit Functions and Reset Values (continued)

REGISTER	REGISTER BIT															
	15	14	13	12	11	10	9	8	7	6	5	4	3	2	1	0
BT	BT15	BT14	BT13	BT12	BT11	BT10	BT9	BT8	BT7	BT6	BT5	BT4	BT3	BT2	BT1	BT0
TMR	TMR15	TMR14	TMR13	TMR12	TMR11	TMR10	TMR9	TMR8	TMR7	TMR6	TMR5	TMR4	TMR3	TMR2	TMR1	TMR0
BPH	BSTT	BOS	—	—	—	—	BPH9	BPH8	BPH7	BPH6	BPH5	BPH4	BPH3	BPH2	BPH1	BPH0
BTRN	BDIV3	BDIV2	BDIV1	BPOL	BCKS	BTRI	BGT	BCTN7	BCTN6	BCTN5	BCTN4	BCTN3	BCTN2	BCTN1	BCTN0	
SARC	—	—	—	SARMX2	SARMX1	SARMX0	SARDJF	SARBIP	SARDJUL	SARSSEL	SARASD	SARBY	SARC2	SARC1	SARC0	
RCVC	—	—	—	—	—	—	LNAOSEL	LNAISEL1	LNAISEL0	—	RCVGN4	RCVGN3	RCVGN2	RCVGN1	RCVGN0	
PLLF	—	—	—	—	—	PLLC0	PLLC1	PLLF8	PLLF7	PLLF6	PLLF5	PLLF4	PLLF3	PLLF2	PLLF1	PLLF0
AIE	—	—	—	—	—	—	—	XTIE	VIBIE	VDBIE	VABIE	CMPIE	LFLIE	LPFIE	SARIE	
CMPC	CMPP	CMPH14	CMPH13	CMPH12	CMPH11	CMPH10	CMPH9	CMPH8	CMPH7	CMPH6	CMPH5	CMPH4	CMPH3	CMPH2	CMPH1	CMPH0
CMPT	CMPT15	CMPT14	CMPT13	CMPT12	CMPT11	CMPT10	CMPT9	CMPT8	CMPT7	CMPT6	CMPT5	CMPT4	CMPT3	CMPT2	CMPT1	CMPT0
ASR	VIOLVL	DVLVL	AVLVL	CMPLVL	—	—	—	XTRDY	XTI	VIBI	VDBI	VABI	CMPI	LPFFL	LPFRDY	SARRDY
SARD	—	—	—	—	SARD11	SARD10	SARD9	SARD8	SARD7	SARD6	SARD5	SARD4	SARD3	SARD2	SARD1	SARD0
LPFC	FFIL3	FFIL2	FFIL1	FFILO	FFDP3	FFDP2	FFDP1	FFDP0	FFOV	—	—	—	FFLD	FFLS2	FFLS1	FFLS0
OSCC	—	—	—	—	—	—	—	—	—	—	—	—	SARCD1	SARCD0	XTE	RCE
BPFI	BPFI15	BPFI14	BPFI13	BPFI12	BPFI11	BPFI10	BPFI9	BPFI8	BPFI7	BPFI6	BPFI5	BPFI4	BPFI3	BPFI2	BPFI1	BPFI0
BPFO	BPFO15	BPFO14	BPFO13	BPFO12	BPFO11	BPFO10	BPFO9	BPFO8	BPFO7	BPFO6	BPFO5	BPFO4	BPFO3	BPFO2	BPFO1	BPFO0
LPFD	LPFD15	LPFD14	LPFD13	LPFD12	LPFD11	LPFD10	LPFD9	LPFD8	LPFD7	LPFD6	LPFD5	LPFD4	LPFD3	LPFD2	LPFD1	LPFD0
LPFF	LPFF15	LPFF14	LPFF13	LPFF12	LPFF11	LPFF10	LPFF9	LPFF8	LPFF7	LPFF6	LPFF5	LPFF4	LPFF3	LPFF2	LPFF1	LPFF0
APE	—	RBUFE	RSARE	BGE	LRIOPD	LRODP	LRAPD	VIBE	VDPE	VDBE	VABE	SARE	PLE	MDE	LNAE	BIASE
	0	0	0	0	0	0	0	0	1	0	0	0	0	0	0	0

NOT INITIALIZED

16-Bit, RISC, Microcontroller-Based, Ultrasonic Distance-Measuring System

Table 4. Peripheral Register Bit Functions and Reset Values (continued)

REGISTER	15	14	13	12	11	10	9	8	REGISTER BIT							
									7	6	5	4	3	2	1	0
FGAIN								[15:0]	0x7B5C							
B1COEF								[15:0]	0x2492							
B2COEF								[15:0]	0x5820							
B3COEF								[15:0]	0x2410							
A2A								[15:0]	0x30F4							
A2B								[15:0]	0x3369							
A2D								[15:0]	0x3A28							
A3A								[15:0]	0xE20E							
A3B								[15:0]	0xE1E3							
A3D								[15:0]	0xE569							

Bits indicated by "ST" reflect the input signal state.

Bits indicated by "P" are cleared to 00h on POR and then, if required, initialized to a value stored within the flash information block.

Bits indicated by "DB" have read/write access only in background or debug mode. These bits are cleared after a POR.

Bits indicated by "DW" are only written to in debug mode. These bits are cleared after a POR.

The OSCC register is cleared to 0002h after a POR and is not affected by other forms of reset.

16-Bit, RISC, Microcontroller-Based, Ultrasonic Distance-Measuring System

MAXQ7667

Applications Information

Development and Technical Support

A variety of highly versatile, affordably priced development tools for this μ C are available from Maxim and third-party suppliers, including:

- Compilers
- Evaluation kit
- Integrated development environments (IDEs)
- JTAG-to-serial converters for programming and debugging

A partial list of development tool vendors can be found at [www.maxim-ic.com/MAXQ tools](http://www.maxim-ic.com/MAXQ_tools).

Technical support is available at <https://support.maxim-ic.com/micro>.

Additional Documentation

Designers must have the following documents to fully use all the features of this device. This data sheet contains pin descriptions, feature overviews, and electrical specifications. Errata sheets contain deviations from published specifications. The user's guides offer detailed information about device features and operation. The following documents can be downloaded from www.maxim-ic.com/microcontrollers.

- This MAXQ7667 data sheet, which contains electrical/timing specifications and pin descriptions.
- The MAXQ7667 revision-specific errata sheet (www.maxim-ic.com/errata).
- The *MAXQ7667 Family User's Guide*, which contains detailed information on core features and operation, including programming.

Pin Configuration

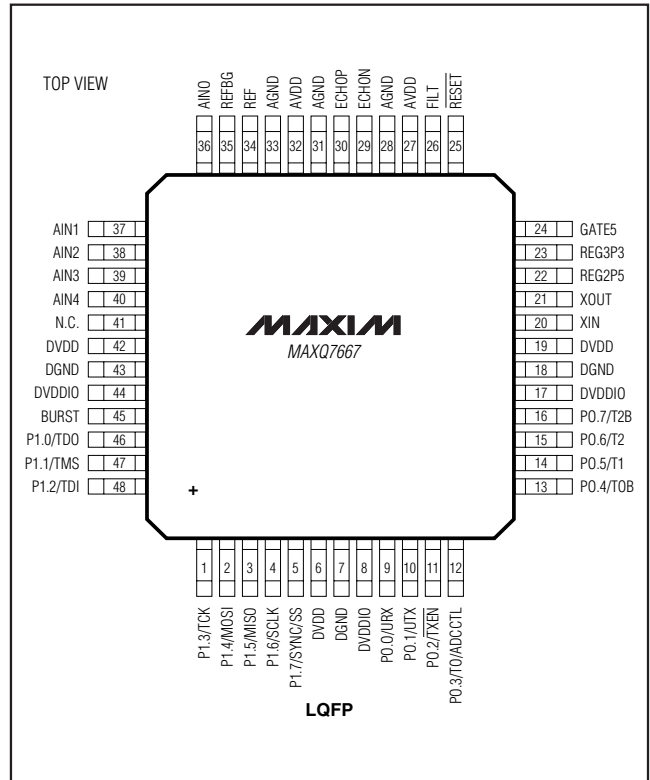

Chip Information

PROCESS: CMOS

Package Information

For the latest package outline information and land patterns, go to www.maxim-ic.com/packages.

PACKAGE TYPE	PACKAGE CODE	DOCUMENT NO.
48 LQFP	C48+2	21-0054

16-Bit, RISC, Microcontroller-Based, Ultrasonic Distance-Measuring System

Revision History

REVISION NUMBER	REVISION DATE	DESCRIPTION	PAGES CHANGED
0	4/09	Initial release	—
1	7/09	Updated <i>Ordering Information</i> to indicate automotive qualified part	1

Maxim cannot assume responsibility for use of any circuitry other than circuitry entirely embodied in a Maxim product. No circuit patent licenses are implied. Maxim reserves the right to change the circuitry and specifications without notice at any time.

40 _____ **Maxim Integrated Products, 120 San Gabriel Drive, Sunnyvale, CA 94086 408-737-7600**

© 2009 Maxim Integrated Products

Maxim is a registered trademark of Maxim Integrated Products, Inc.