



# Low-Power Battery Backup Circuits in Small $\mu$ DFN Packages

**MAX16033–MAX16040**

## General Description

The MAX16033–MAX16040 supervisory circuits reduce the complexity and number of components required for power-supply monitoring and battery control functions in microprocessor ( $\mu$ P) systems. The devices significantly improve system reliability and accuracy compared to other ICs or discrete components. The MAX16033–MAX16040 provide  $\mu$ P reset, backup-battery switchover, power-fail warning, watchdog, and chip-enable gating features.

The MAX16033–MAX16040 operate from supply voltages up to 5.5V. The factory-set reset threshold voltage ranges from 2.32V to 4.63V. The devices feature a manual-reset input (MAX16033/MAX16037), a watchdog timer input (MAX16034/MAX16038), a battery-on output (MAX16035/MAX16039), an auxiliary adjustable reset input (MAX16036/MAX16040), and chip-enable gating (MAX16033–MAX16036). Each device includes a power-fail comparator and offers an active-low push-pull reset or an active-low open-drain reset.

The MAX16033–MAX16040 are available in 2mm x 2mm, 8-pin or 10-pin  $\mu$ DFN packages and are fully specified from  $-40^{\circ}\text{C}$  to  $+85^{\circ}\text{C}$ .

## Applications

Portable/Battery-Powered Equipment	Controllers
POS Equipment	Computers
Critical $\mu$ P/ $\mu$ C Power Monitoring	Fax Machines
Set-Top Boxes	Industrial Control
	Real-Time Clocks
	Intelligent Instrument

**Pin Configurations and Typical Operating Circuit appear at end of data sheet.**

## Features

- ◆ Low 1.2V Operating Supply Voltage
- ◆ Precision Monitoring of 5.0V, 3.3V, 3.0V, and 2.5V Power-Supply Voltages
- ◆ Independent Power-Fail Comparator
- ◆ Debounced Manual-Reset Input
- ◆ Watchdog Timer, 1.6s Timeout
- ◆ Battery-On Output Indicator
- ◆ Auxiliary User-Adjustable RESETIN
- ◆ Low 13 $\mu$ A Quiescent Supply Current
- ◆ Two Available Output Structures:  
Active-Low Push-Pull Reset  
Active-Low Open-Drain Reset
- ◆ Active-Low Reset Valid Down to 1.2V
- ◆ Power-Supply Transient Immunity
- ◆ 140ms (min) Reset Timeout Period
- ◆ Small 2mm x 2mm, 8-Pin and 10-Pin  $\mu$ DFN Packages

## Ordering Information

PART*	TEMP RANGE	PIN-PACKAGE	PKG CODE
MAX16033LLB_+_T	$-40^{\circ}\text{C}$ to $+85^{\circ}\text{C}$	10 $\mu$ DFN-10	L1022-1
MAX16033PLB_+_T	$-40^{\circ}\text{C}$ to $+85^{\circ}\text{C}$	10 $\mu$ DFN-10	L1022-1
MAX16034LLB_+_T	$-40^{\circ}\text{C}$ to $+85^{\circ}\text{C}$	10 $\mu$ DFN-10	L1022-1
MAX16034PLB_+_T	$-40^{\circ}\text{C}$ to $+85^{\circ}\text{C}$	10 $\mu$ DFN-10	L1022-1

**Ordering Information continued on last page.**

\*These parts offer a choice of reset threshold voltages. From the Reset Threshold Ranges table, insert the desired threshold voltage code in the blank to complete the part number. See Selector Guide for a listing of device features.

+Denotes a lead-free package.

T = Tape and reel.

## Selector Guide

PART	$\overline{\text{MR}}$	WATCHDOG	BATTON	RESETIN	$\overline{\text{CEIN}}/\overline{\text{CEOUT}}$	PFI, $\overline{\text{PFO}}$	PIN-PACKAGE
MAX16033_	✓				✓	✓	10 $\mu$ DFN-10
MAX16034_		✓			✓	✓	10 $\mu$ DFN-10
MAX16035_			✓		✓	✓	10 $\mu$ DFN-10
MAX16036_				✓	✓	✓	10 $\mu$ DFN-10
MAX16037_	✓					✓	8 $\mu$ DFN-8
MAX16038_		✓				✓	8 $\mu$ DFN-8
MAX16039_			✓			✓	8 $\mu$ DFN-8
MAX16040_				✓		✓	8 $\mu$ DFN-8

**Note:** Replace “\_” with L for push-pull or P for open-drain  $\overline{\text{RESET}}$  and  $\overline{\text{PFO}}$  outputs.



Maxim Integrated Products 1

**For pricing, delivery, and ordering information, please contact Maxim Direct at 1-888-629-4642, or visit Maxim's website at [www.maxim-ic.com](http://www.maxim-ic.com).**

# Low-Power Battery Backup Circuits in Small $\mu$ DFN Packages

## ABSOLUTE MAXIMUM RATINGS

Terminal Voltages (with respect to GND)

$V_{CC}$ , BATT, OUT .....	-0.3V to +6V
$\overline{RESET}$ (open drain), $\overline{PFO}$ (open drain) .....	-0.3V to +6V
$\overline{RESET}$ (push-pull), $\overline{PFO}$ (push-pull), BATTON, RESETIN, WDI	
MR, CEIN, CEOUT, PFI .....	-0.3V to ( $V_{OUT} + 0.3V$ )

Input Current

$V_{CC}$ Peak .....	1A
$V_{CC}$ Continuous .....	250mA
BATT Peak .....	250mA
BATT Continuous .....	40mA
GND .....	75mA

Output Current

OUT .....	Short-Circuit Protected for up to 5s
$\overline{RESET}$ , BATTON .....	20mA
Continuous Power Dissipation ( $T_A = +70^\circ\text{C}$ )	
8-Pin $\mu$ DFN (derate 4.8mW/ $^\circ\text{C}$ above $+70^\circ\text{C}$ ) .....	380.6mW
10-Pin $\mu$ DFN (derate 5mW/ $^\circ\text{C}$ above $+70^\circ\text{C}$ ) .....	402.8mW
Operating Temperature Range .....	$-40^\circ\text{C}$ to $+85^\circ\text{C}$
Storage Temperature Range .....	$-65^\circ\text{C}$ to $+150^\circ\text{C}$
Lead Temperature (soldering, 10s) .....	$+300^\circ\text{C}$

Stresses beyond those listed under "Absolute Maximum Ratings" may cause permanent damage to the device. These are stress ratings only, and functional operation of the device at these or any other conditions beyond those indicated in the operational sections of the specifications is not implied. Exposure to absolute maximum rating conditions for extended periods may affect device reliability.

## ELECTRICAL CHARACTERISTICS

( $V_{CC} = 2.25V$  to  $5.5V$ ,  $V_{BATT} = 3V$ ,  $\overline{RESET}$  not asserted,  $T_A = -40^\circ\text{C}$  to  $+85^\circ\text{C}$ , unless otherwise noted. Typical values are at  $T_A = +25^\circ\text{C}$ .) (Note 1)

PARAMETER	SYMBOL	CONDITIONS	MIN	TYP	MAX	UNITS
Operating Voltage Range	$V_{CC}$ , $V_{BATT}$	No load (Note 2)	0		5.5	V
Supply Current	$I_{CC}$	No load, $V_{CC} > V_{TH}$	$V_{CC} = 2.8V$	13	30	$\mu\text{A}$
			$V_{CC} = 3.6V$	16	35	
			$V_{CC} = 5.5V$	22	50	
Supply Current in Battery Backup Mode		$V_{BATT} = 2.8V$ , $V_{CC} = 0V$ , excluding $I_{OUT}$	$T_A = +25^\circ\text{C}$		1	$\mu\text{A}$
			$T_A = -40^\circ\text{C}$ to $+85^\circ\text{C}$		2	
BATT Standby Current (Note 3)	$I_{BATT}$	$(V_{BATT} + 0.2V) < V_{CC}$ < 5.5V	$T_A = +25^\circ\text{C}$	-0.1	+0.02	$\mu\text{A}$
			$T_A = -40^\circ\text{C}$ to $+85^\circ\text{C}$	-0.3	+0.02	
$V_{CC}$ to OUT On-Resistance	$R_{ON}$	$V_{CC} = 4.75V$ , $V_{CC} > V_{TH}$ , $I_{OUT} = 150mA$			3.1	$\Omega$
			$V_{CC} = 3.15V$ , $V_{CC} > V_{TH}$ , $I_{OUT} = 65mA$		3.7	
			$V_{CC} = 2.5V$ , $V_{CC} > V_{TH}$ , $I_{OUT} = 25mA$		4.6	
Output Voltage in Battery Backup Mode	$V_{OUT}$	$V_{BATT} = 4.50V$ , $V_{CC} = 0V$ , $I_{OUT} = 20mA$	$V_{BATT}$			V
		$V_{BATT} = 3.15V$ , $V_{CC} = 0V$ , $I_{OUT} = 10mA$	$V_{BATT}$			
		$V_{BATT} = 2.5V$ , $V_{CC} = 0V$ , $I_{OUT} = 5mA$	$V_{BATT}$			
Battery-Switchover Threshold	$V_{SW}$	$V_{CC} - V_{BATT}$ , $V_{CC} < V_{TH}$	$V_{CC}$ rising	0		mV
			$V_{CC}$ falling		-40	

# Low-Power Battery Backup Circuits in Small $\mu$ DFN Packages

MAX16033-MAX16040

## ELECTRICAL CHARACTERISTICS (continued)

( $V_{CC}$  = 2.25V to 5.5V,  $V_{BATT}$  = 3V,  $\overline{RESET}$  not asserted,  $T_A$  = -40°C to +85°C, unless otherwise noted. Typical values are at  $T_A$  = +25°C.) (Note 1)

PARAMETER	SYMBOL	CONDITIONS	MIN	TYP	MAX	UNITS
<b>RESET OUTPUT</b>						
Reset Threshold	$V_{TH}$	MAX160__L_46	4.50	4.63	4.75	V
		MAX160__L_44	4.25	4.38	4.50	
		MAX160__L_31	3.00	3.08	3.15	
		MAX160__L_29	2.85	2.93	3.00	
		MAX160__L_26	2.55	2.63	2.70	
MAX160__L_23	2.25	2.32	2.38			
$V_{CC}$ Falling Reset Delay		$V_{CC}$ falling at 10V/ms		25		$\mu$ s
Reset Active Timeout Period	$t_{RP}$		140		280	ms
$\overline{RESET}$ Output Low Voltage	$V_{OL}$	$\overline{RESET}$ asserted	$I_{SINK} = 1.6\text{mA}$ , $V_{CC} \geq 2.1\text{V}$		0.3	V
			$I_{SINK} = 100\mu\text{A}$ , $V_{CC} \geq 1.2\text{V}$		0.4	
$\overline{RESET}$ Output High Voltage	$V_{OH}$	MAX160__L only (push-pull), $\overline{RESET}$ not asserted, $I_{SOURCE} = 500\mu\text{A}$ , $V_{CC} \geq V_{TH(MAX)}$	0.8 x $V_{CC}$			V
$\overline{RESET}$ Output Leakage Current	$I_{LKG}$	MAX160__P only (open drain), not asserted			1	$\mu$ A
<b>POWER-FAIL COMPARATOR</b>						
PFI Input Threshold	$V_{PFI}$	$V_{PFI}$ falling	1.185	1.235	1.285	V
PFI Hysteresis				1		%
PFI Input Current		$V_{PFI} = 0\text{V}$ or $V_{CC}$	-100		+100	nA
$\overline{PFO}$ Output Low Voltage	$V_{OL}$	Output asserted	$V_{CC} \geq 2.1\text{V}$ , $I_{SINK} = 1.6\text{mA}$		0.3	V
			$V_{CC} \geq 1.2\text{V}$ , $I_{SINK} = 100\mu\text{A}$		0.4	
$\overline{PFO}$ Output High Voltage	$V_{OH}$	MAX160__L only (push-pull), $V_{CC} \geq V_{TH(MAX)}$ , $I_{SOURCE} = 500\mu\text{A}$ , output not asserted	0.8 x $V_{CC}$			V
$\overline{PFO}$ Leakage Current		MAX160__P only (open drain), $V_{PFO} = 5.5\text{V}$ , not asserted			1	$\mu$ A
$\overline{PFO}$ Delay Time		$V_{PFI} + 100\text{mV}$ to $V_{PFI} - 100\text{mV}$		4		$\mu$ s
<b>MANUAL RESET (MAX16033/MAX16037)</b>						
$\overline{MR}$ Input Voltage	$V_{IL}$				0.3 x $V_{CC}$	V
	$V_{IH}$		0.7 x $V_{CC}$			
Pullup Resistance to $V_{CC}$			20		165	k $\Omega$
Minimum Pulse Width			1			$\mu$ s
Glitch Immunity		$V_{CC} = 3.3\text{V}$		100		ns
$\overline{MR}$ to Reset Delay				120		ns

# Low-Power Battery Backup Circuits in Small $\mu$ DFN Packages

## ELECTRICAL CHARACTERISTICS (continued)

( $V_{CC} = 2.25V$  to  $5.5V$ ,  $V_{BATT} = 3V$ ,  $\overline{RESET}$  not asserted,  $T_A = -40^\circ C$  to  $+85^\circ C$ , unless otherwise noted. Typical values are at  $T_A = +25^\circ C$ .) (Note 1)

PARAMETER	SYMBOL	CONDITIONS	MIN	TYP	MAX	UNITS
<b>WATCHDOG (MAX16034/MAX16038)</b>						
Watchdog Timeout Period	tWD		1.00	1.65	2.25	s
Minimum WDI Input Pulse Width	tWDI	(Note 4)	100			ns
WDI Input Voltage	$V_{IL}$				$0.3 \times V_{CC}$	V
	$V_{IH}$		$0.7 \times V_{CC}$			
WDI Input Current			-1.0		+1.0	$\mu A$
<b>BATTON (MAX16035/MAX16039)</b>						
Output Voltage	$V_{OL}$	$I_{SINK} = 3.2mA$ , $V_{BATT} = 2.1V$			0.4	V
Output Short-Circuit Current		Sink current, $V_{CC} = 5V$		60		mA
		Source current, $V_{BATT} \geq 2V$	10	30	120	$\mu A$
<b>RESETIN (MAX16036/MAX16040)</b>						
RESETIN Threshold	$V_{RTH}$		1.185	1.235	1.285	V
RESETIN Input Current				0.01	25	nA
RESETIN to Reset Delay		$(V_{RTH} + 100mV)$ to $(V_{RTH} - 100mV)$		1.5		$\mu s$
<b>CHIP-ENABLE GATING (MAX16033-MAX16036)</b>						
$\overline{CEIN}$ Leakage Current		$\overline{RESET}$ asserted			$\pm 1$	$\mu A$
$\overline{CEIN}$ to $\overline{CEOUT}$ Resistance		$\overline{RESET}$ not asserted, $V_{CC} = V_{TH(MAX)}$ , $V_{CEIN} = V_{CC} / 2$ , $I_{SINK} = 10mA$			100	$\Omega$
$\overline{CEOUT}$ Short-Circuit Current		$\overline{RESET}$ asserted, $V_{CEOUT} = 0V$		1	2.0	mA
$\overline{CEIN}$ to $\overline{CEOUT}$ Propagation Delay (Note 4)		50 $\Omega$ source impedance driver, $C_{LOAD} = 50pF$	$V_{CC} = 4.75V$	1.5	7	ns
			$V_{CC} = 3.15V$	2	9	
$\overline{CEOUT}$ Output-Voltage High		$V_{CC} = 5V$ , $V_{CC} \geq V_{BATT}$ , $I_{SOURCE} = 100\mu A$	$0.7 \times V_{CC}$			V
		$V_{CC} = 0V$ , $V_{BATT} \geq 2.2V$ , $I_{SOURCE} = 1\mu A$	$V_{BATT} - 0.1$			
$\overline{RESET}$ to $\overline{CEOUT}$ Delay				1		$\mu s$

**Note 1:** All devices are 100% production tested at  $T_A = +25^\circ C$ . All overtemperature limits are guaranteed by design.

**Note 2:**  $V_{BATT}$  can be 0V any time, or  $V_{CC}$  can go down to 0V if  $V_{BATT}$  is active (except at startup).

**Note 3:** Positive current flows into BATT.

**Note 4:** Guaranteed by design.

# Low-Power Battery Backup Circuits in Small $\mu$ DFN Packages

## Typical Operating Characteristics

( $T_A = +25^\circ\text{C}$ , unless otherwise noted.)

MAX16033-MAX16040

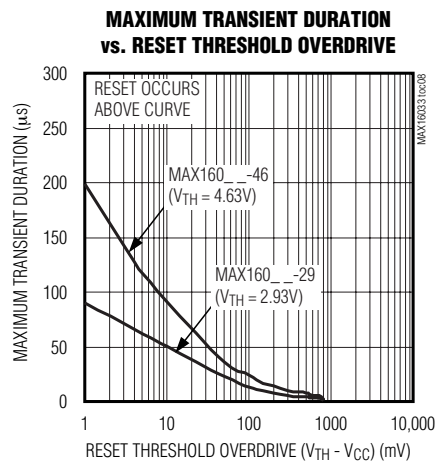
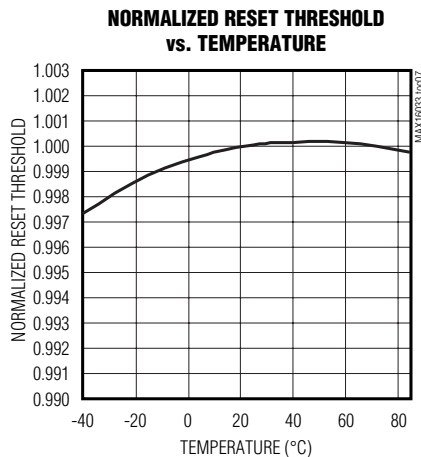
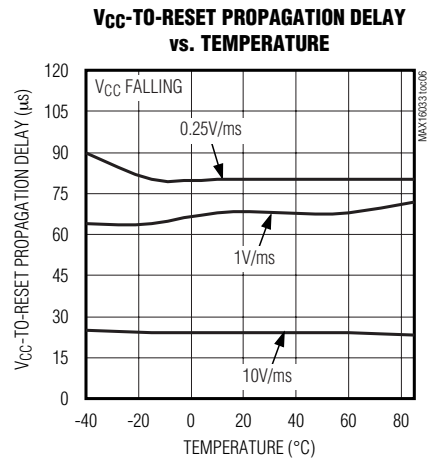
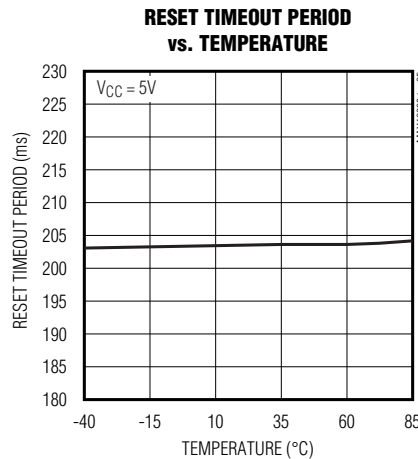
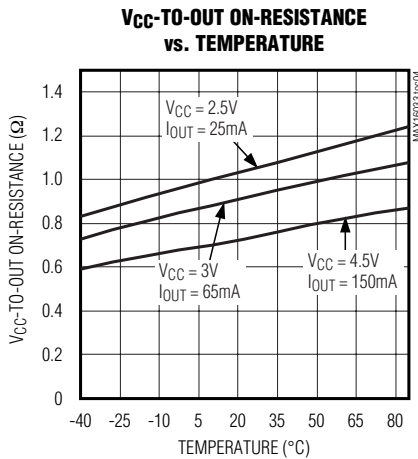
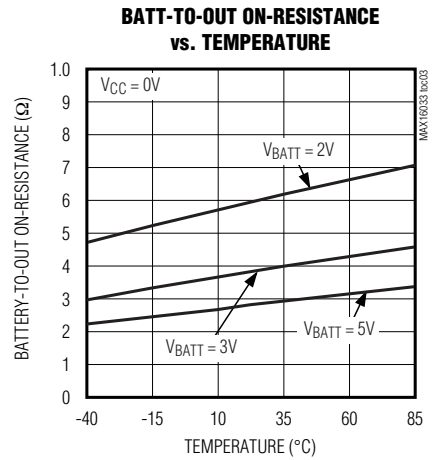
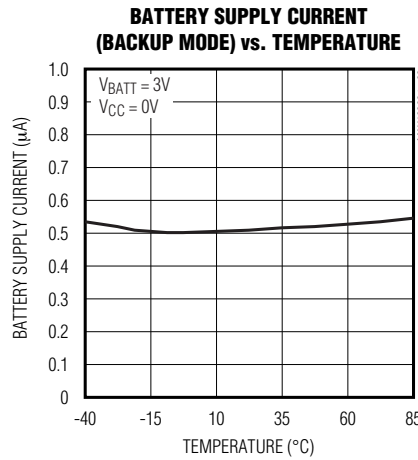
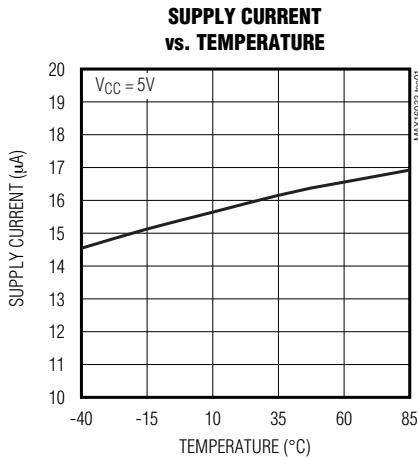

# Low-Power Battery Backup Circuits in Small $\mu$ DFN Packages

## Typical Operating Characteristics (continued)

( $T_A = +25^\circ\text{C}$ , unless otherwise noted.)

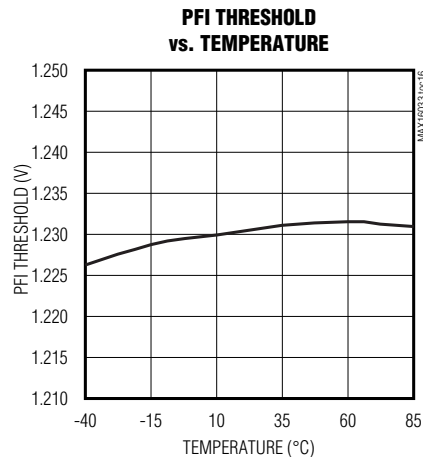
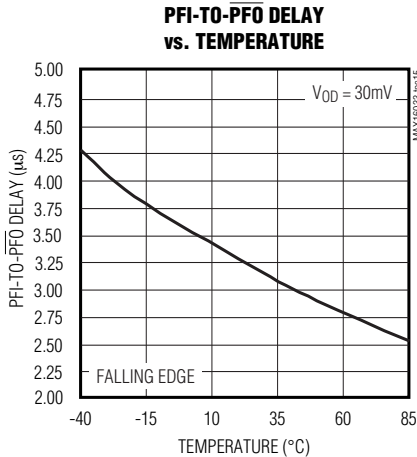
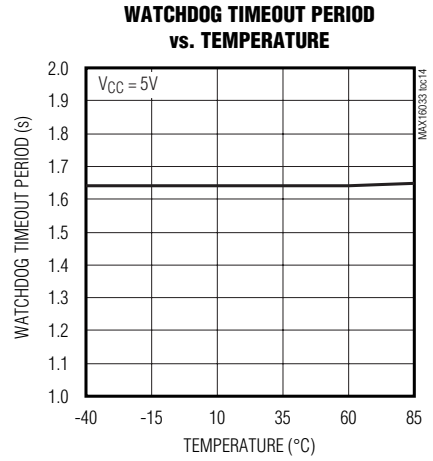
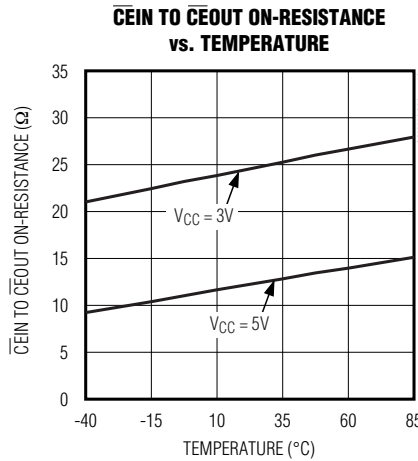
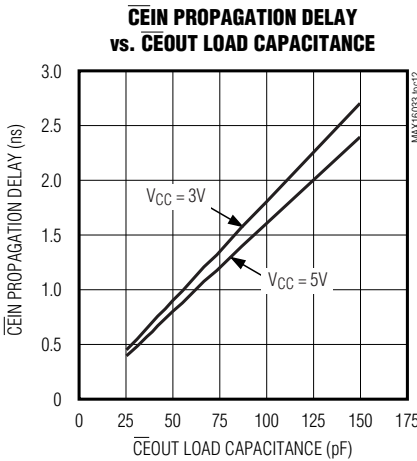
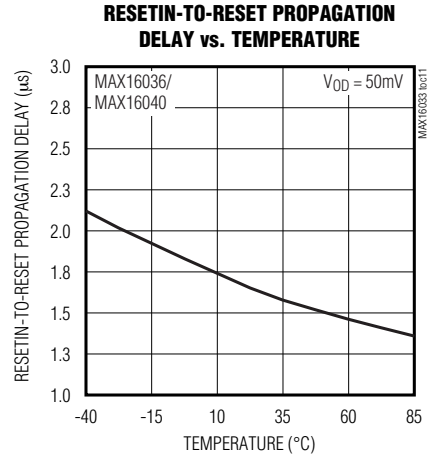
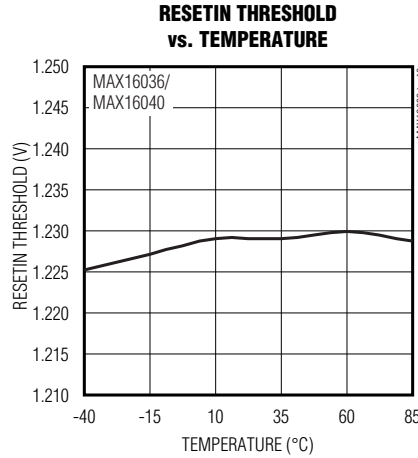
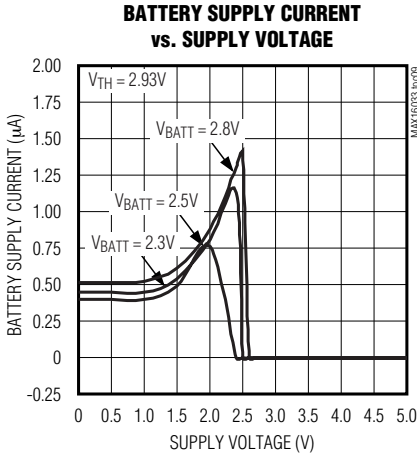

# Low-Power Battery Backup Circuits in Small $\mu$ DFN Packages

## Pin Description

MAX16033-MAX16040

PIN		NAME	FUNCTION
MAX16033-MAX16036 (10-pin $\mu$ DFN)	MAX16037-MAX16040 (8-pin $\mu$ DFN)		
1	1	$\overline{\text{RESET}}$	Active-Low Reset Output. $\overline{\text{RESET}}$ remains low when $V_{CC}$ is below the reset threshold ( $V_{TH}$ ), the manual-reset input is low, or RESE TIN is low. It asserts low in pulses when the internal watchdog times out. $\overline{\text{RESET}}$ remains low for the reset timeout period ( $t_{RP}$ ) after $V_{CC}$ rises above the reset threshold, after the manual-reset input goes from low to high, after RESE TIN goes high, or after the watchdog triggers a reset event. The MAX160_ _L is an active-low push-pull output, while the MAX160_ _P is an active-low open-drain output.
2	—	$\overline{\text{CEIN}}$	Chip-Enable Input. The input to the chip-enable gating circuit. Connect to GND or OUT if not used.
3	2	PFI	Power-Fail Input. $\overline{\text{PFO}}$ goes low when $V_{PFI}$ falls below 1.235V.
4	3	GND	Ground
5	4	$\overline{\text{MR}}$	Manual-Reset Input (MAX16033/MAX16037). Driving $\overline{\text{MR}}$ low asserts $\overline{\text{RESET}}$ . $\overline{\text{RESET}}$ remains asserted as long as $\overline{\text{MR}}$ is low and for the reset timeout period ( $t_{RP}$ ) after $\overline{\text{MR}}$ transitions from low to high. Leave unconnected, or connect to $V_{CC}$ if not used. $\overline{\text{MR}}$ has an internal 20k $\Omega$ pullup to $V_{CC}$ .
		WDI	Watchdog Input (MAX16034/MAX16038). If WDI remains high or low for longer than the watchdog timeout period ( $t_{WD}$ ), the internal watchdog timer runs out and a reset pulse is triggered for the reset timeout period ( $t_{RP}$ ). The internal watchdog clears whenever $\overline{\text{RESET}}$ asserts or whenever WDI sees a rising or falling edge (Figure 2).
		BATTON	Battery-On Output (MAX16035/MAX16039). BATTON goes high during battery backup mode.
		RESE TIN	Reset Input (MAX16036/MAX16040). When RESE TIN falls below 1.235V, $\overline{\text{RESET}}$ asserts. $\overline{\text{RESET}}$ remains asserted as long as RESE TIN is low and for at least $t_{RP}$ after RESE TIN goes high.
6	5	$\overline{\text{PFO}}$	Active-Low Power-Fail Output. $\overline{\text{PFO}}$ goes low when $V_{PFI}$ falls below 1.235V. $\overline{\text{PFO}}$ stays low until $V_{PFI}$ goes above 1.235V. $\overline{\text{PFO}}$ also goes low when $V_{CC}$ falls below the reset threshold voltage.
7	6	$V_{CC}$	Supply Voltage, 1.2V to 5.5V
8	7	OUT	Output. OUT sources from $V_{CC}$ when $\overline{\text{RESET}}$ is not asserted and from the greater of $V_{CC}$ or BATT when $V_{CC}$ is below the reset threshold voltage.
9	8	BATT	Backup Battery Input. When $V_{CC}$ falls below the reset threshold, OUT switches to BATT if $V_{BATT}$ is 40mV greater than $V_{CC}$ . When $V_{CC}$ rises above $V_{BATT}$ , OUT switches to $V_{CC}$ . The 40mV hysteresis prevents repeated switching if $V_{CC}$ falls slowly.
10	—	$\overline{\text{CEOUT}}$	Chip-Enable Output. $\overline{\text{CEOUT}}$ goes low only when $\overline{\text{CEIN}}$ is low and reset is not asserted. When $\overline{\text{CEOUT}}$ is disconnected from $\overline{\text{CEIN}}$ , $\overline{\text{CEOUT}}$ is actively pulled up to OUT.

# Low-Power Battery Backup Circuits in Small $\mu$ DFN Packages

## Functional Diagram

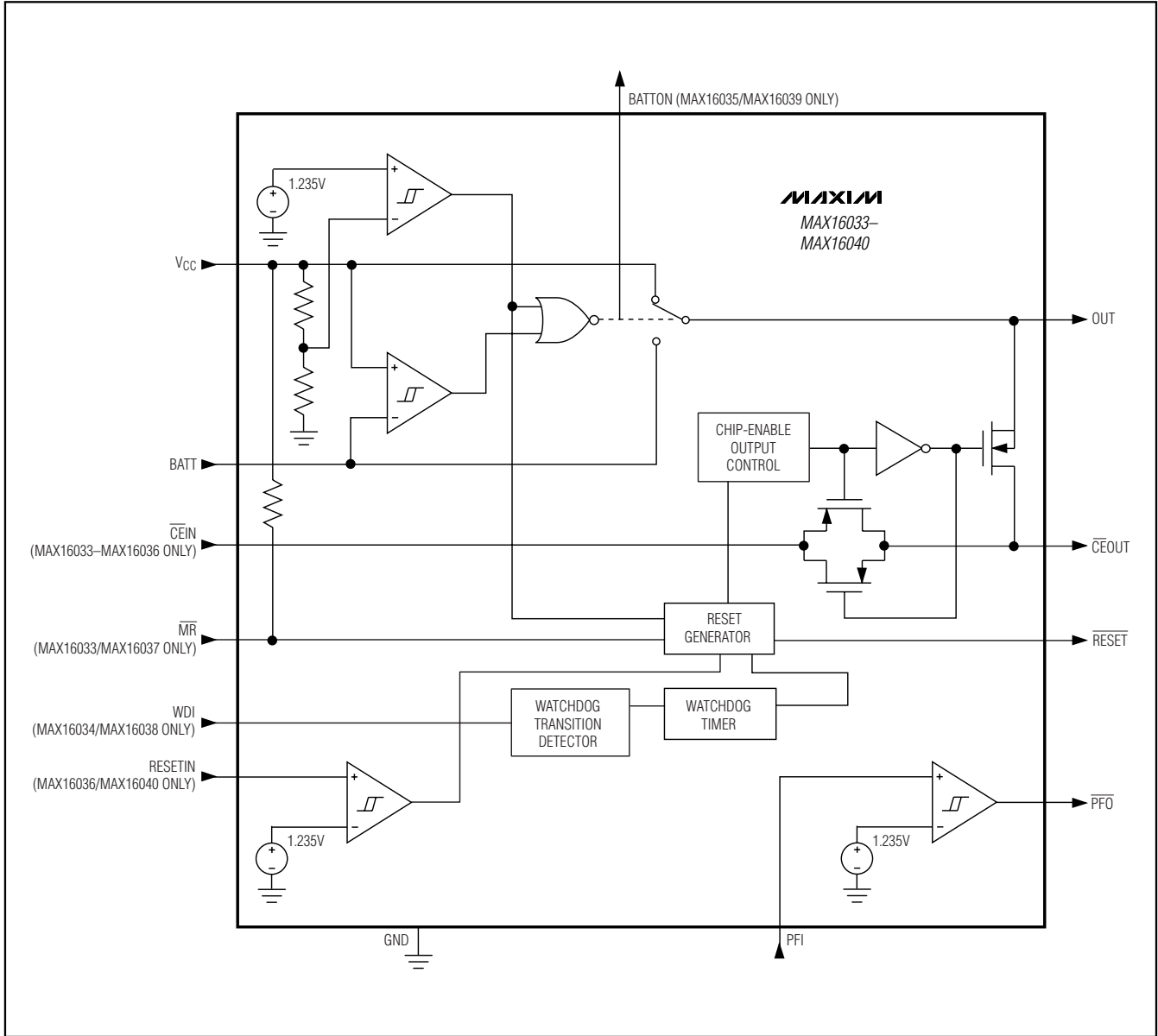



# Low-Power Battery Backup Circuits in Small $\mu$ DFN Packages

MAX16033-MAX16040

## Detailed Description

The *Typical Operating Circuit* shows a typical connection for the MAX16033-MAX16040. OUT powers the static random-access memory (SRAM). If  $V_{CC}$  is greater than the reset threshold ( $V_{TH}$ ), or if  $V_{CC}$  is lower than  $V_{TH}$  but higher than  $V_{BATT}$ ,  $V_{CC}$  is connected to OUT. If  $V_{CC}$  is lower than  $V_{TH}$  and  $V_{CC}$  is less than  $V_{BATT}$ , BATT is connected to OUT. OUT supplies up to 200mA from  $V_{CC}$ . In battery-backup mode, an internal MOSFET connects the backup battery to OUT. The on-resistance of the MOSFET is a function of the backup-battery voltage and temperature and is shown in the BATT-to-OUT On-Resistance vs. Temperature graph in the *Typical Operating Characteristics*.

### Chip-Enable Signal Gating (MAX16033-MAX16036 Only)

The MAX16033-MAX16036 provide internal gating of chip-enable ( $\overline{CE}$ ) signals to prevent erroneous data from being written to CMOS RAM in the event of a power failure or brownout condition. During normal operation, the  $\overline{CE}$  gate is enabled and passes all  $\overline{CE}$  transitions. When reset asserts, this path becomes disabled, preventing erroneous data from corrupting the CMOS RAM. The MAX16033-MAX16036 provide a series transmission gate from  $\overline{CEIN}$  to  $\overline{CEOUT}$ . A 2ns (typ) propagation delay from  $\overline{CEIN}$  to  $\overline{CEOUT}$  allows

these devices to be used with most  $\mu$ Ps and high-speed DSPs.

When  $\overline{RESET}$  is deasserted,  $\overline{CEIN}$  is connected to  $\overline{CEOUT}$  through a low on-resistance transmission gate. If  $\overline{CEIN}$  is high when  $\overline{RESET}$  is asserted,  $\overline{CEOUT}$  remains high regardless of any subsequent transitions on  $\overline{CEIN}$  during the reset event.

If  $\overline{CEIN}$  is low when  $\overline{RESET}$  is asserted,  $\overline{CEOUT}$  is held low for 1 $\mu$ s to allow completion of the read/write operation (Figure 1). After the 1 $\mu$ s delay expires,  $\overline{CEOUT}$  goes high and stays high regardless of any subsequent transitions on  $\overline{CEIN}$  during the reset event. When  $\overline{CEOUT}$  is disconnected from  $\overline{CEIN}$ ,  $\overline{CEOUT}$  is actively pulled up to OUT.

The propagation delay through the chip-enable circuitry depends on both the source impedance of the drive to  $\overline{CEIN}$  and the capacitive loading at  $\overline{CEOUT}$ . The chip-enable propagation delay is specified from the 50% point of  $\overline{CEIN}$  to the 50% point of  $\overline{CEOUT}$ , using a 50 $\Omega$  driver and 50pF load capacitance. Minimize the capacitive load at  $\overline{CEOUT}$  and use a low output-impedance driver to minimize propagation delay.

In high-impedance mode, the leakage current at  $\overline{CEIN}$  is  $\pm 1\mu$ A (max) over temperature. In low-impedance mode, the impedance of  $\overline{CEIN}$  appears as a 75 $\Omega$  resistor in series with the load at  $\overline{CEOUT}$ .

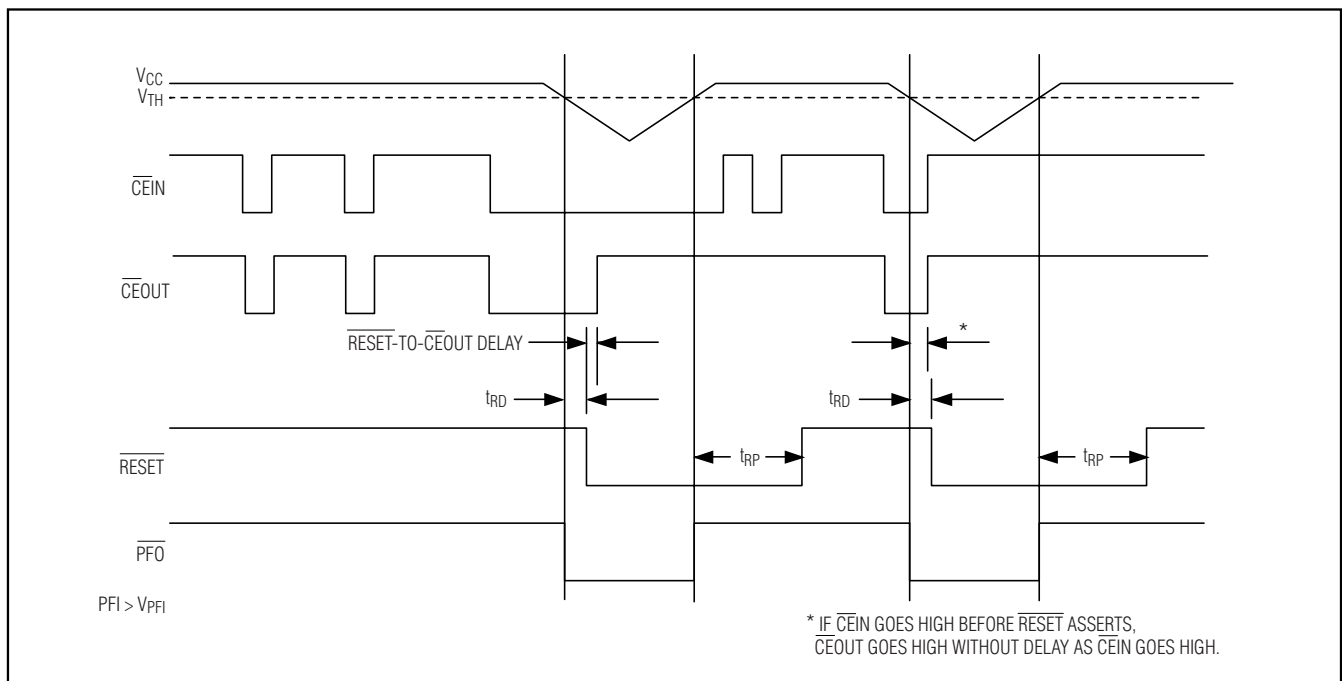

Figure 1.  $\overline{RESET}$  and Chip-Enable Timing

# Low-Power Battery Backup Circuits in Small $\mu$ DFN Packages

## Backup Battery Switchover

To preserve the contents of the RAM in a brownout or power failure, the MAX16033–MAX16040 automatically switch to back up the battery installed at BATT when the following two conditions are met:

- 1)  $V_{CC}$  falls below the reset threshold voltage.
- 2)  $V_{CC}$  is below  $V_{BATT}$ .

Table 1 lists the status of the inputs and outputs in battery-backup mode. The devices do not power-up if the only voltage source is  $V_{BATT}$ . OUT only powers up from  $V_{CC}$  at startup.

**Table 1. Input and Output Status in Battery-Backup Mode**

PIN	STATUS
$V_{CC}$	Disconnected from OUT
OUT	Connected to BATT
BATT	Connected to OUT. Current drawn from the battery is less than $1\mu\text{A}$ (at $V_{BATT} = 2.8\text{V}$ , excluding $I_{OUT}$ ) when $V_{CC} = 0\text{V}$ .
$\overline{\text{RESET}}$	Asserted
BATTON	High state
$\overline{\text{MR}}$ , $\overline{\text{RESETIN}}$ , $\overline{\text{CEIN}}$ , and WDI	Inputs ignored
$\overline{\text{CEOUT}}$	Connected to OUT
$\overline{\text{PFO}}$	Asserted

## Manual-Reset Input (MAX16033/MAX16037 Only)

Many  $\mu\text{P}$ -based products require manual-reset capability, allowing the user or external logic circuitry to initiate a reset. For the MAX16033/MAX16037, a logic-low on  $\overline{\text{MR}}$  asserts  $\overline{\text{RESET}}$ .  $\overline{\text{RESET}}$  remains asserted while  $\overline{\text{MR}}$  is low and for a minimum of  $140\text{ms}$  ( $t_{RP}$ ) after it returns high.  $\overline{\text{MR}}$  has an internal  $20\text{k}\Omega$  (min) pullup resistor to

$V_{CC}$ . This input can be driven from TTL/CMOS logic outputs or with open-drain/collector outputs. Connect a normally-open momentary switch from  $\overline{\text{MR}}$  to GND to create a manual-reset function; external debounce circuitry is not required. When driving  $\overline{\text{MR}}$  from long cables or when using the device in a noisy environment, connect a  $0.1\mu\text{F}$  capacitor from  $\overline{\text{MR}}$  to GND to provide additional noise immunity.

## Watchdog Input (MAX16034/MAX16038 Only)

The watchdog monitors  $\mu\text{P}$  activity through the watchdog input (WDI).  $\overline{\text{RESET}}$  asserts when the  $\mu\text{P}$  fails to toggle WDI. Connect WDI to a bus line or  $\mu\text{P}$  I/O line. A change of state (high to low, low to high, or a minimum  $100\text{ns}$  pulse) resets the watchdog timer. If WDI remains high or low for longer than the watchdog timeout period ( $t_{WD}$ ), the internal watchdog timer runs out and triggers a reset pulse for the reset timeout period ( $t_{RP}$ ). The internal watchdog timer clears whenever reset is asserted or whenever WDI sees a rising or falling edge. If WDI remains in either a high or low state, a reset pulse periodically asserts after every watchdog timeout period ( $t_{WD}$ ); see Figure 2.

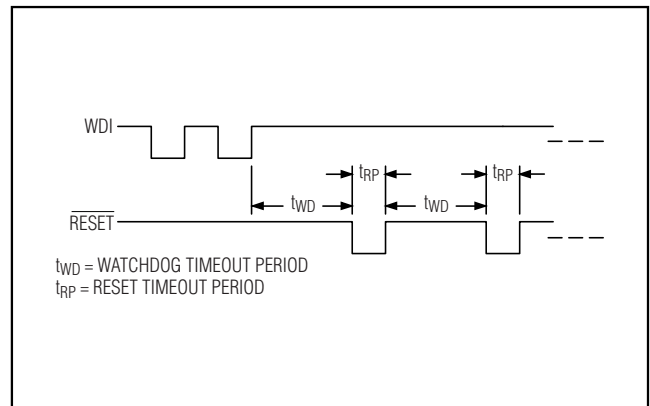

Figure 2. MAX16034/MAX16038 Watchdog Timeout Period and Reset Active Time

# Low-Power Battery Backup Circuits in Small $\mu$ DFN Packages

## BATTON Indicator (MAX16035/MAX16039 Only)

BATTON is a push-pull output that asserts high when in battery-backup mode. BATTON typically sinks 3.2mA at a 0.4V saturation voltage. In battery-backup mode, this terminal sources approximately 10 $\mu$ A from OUT. Use BATTON to indicate battery-switchover status or to supply base drive to an external pass transistor for higher current applications (see Figure 3).

## RESETIN Comparator (MAX16036/MAX16040 Only)

An internal 1.235V reference sets the RESETIN threshold voltage. RESET asserts when the voltage at RESETIN is below 1.235V. Use the RESETIN function to monitor a secondary power supply.

Use the following equations to set the reset threshold voltage ( $V_{RTH}$ ) of the secondary power supply (see Figure 4):

$$V_{RTH} = V_{REF} (R1 / R2 + 1)$$

where  $V_{REF} = 1.235V$ . To simplify the resistor selection, choose a value for  $R2$  and calculate  $R1$ .

$$R1 = R2 [(V_{RTH} / V_{REF}) - 1]$$

Since the input current at RESETIN is 25nA (max), large values (up to 1M $\Omega$ ) can be used for  $R2$  with no significant loss in accuracy.

## Power-Fail Comparator

The MAX16033-MAX16040 issue an interrupt (nonmaskable or regular) to the  $\mu$ P when a power failure occurs. The power line is monitored by two external resistors connected to the power-fail input (PFI). When the voltage at PFI falls below 1.235V, the power-fail output (PFO) drives the processor's NMI input low. An earlier power-fail warning can be generated if the unregulated DC input of the regulator is available for monitoring. The MAX16033-MAX16040 turn off the power-fail comparator and force PFO low when  $V_{CC}$  falls below the reset threshold voltage (see Figure 1). The MAX160\_ \_L devices provide push-pull PFO outputs. The MAX160\_ \_P devices provide open-drain PFO outputs.

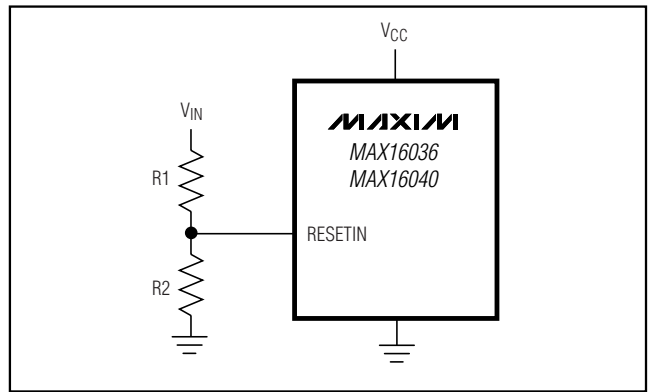

Figure 4. Setting RESETIN Voltage for the MAX16036/MAX16040

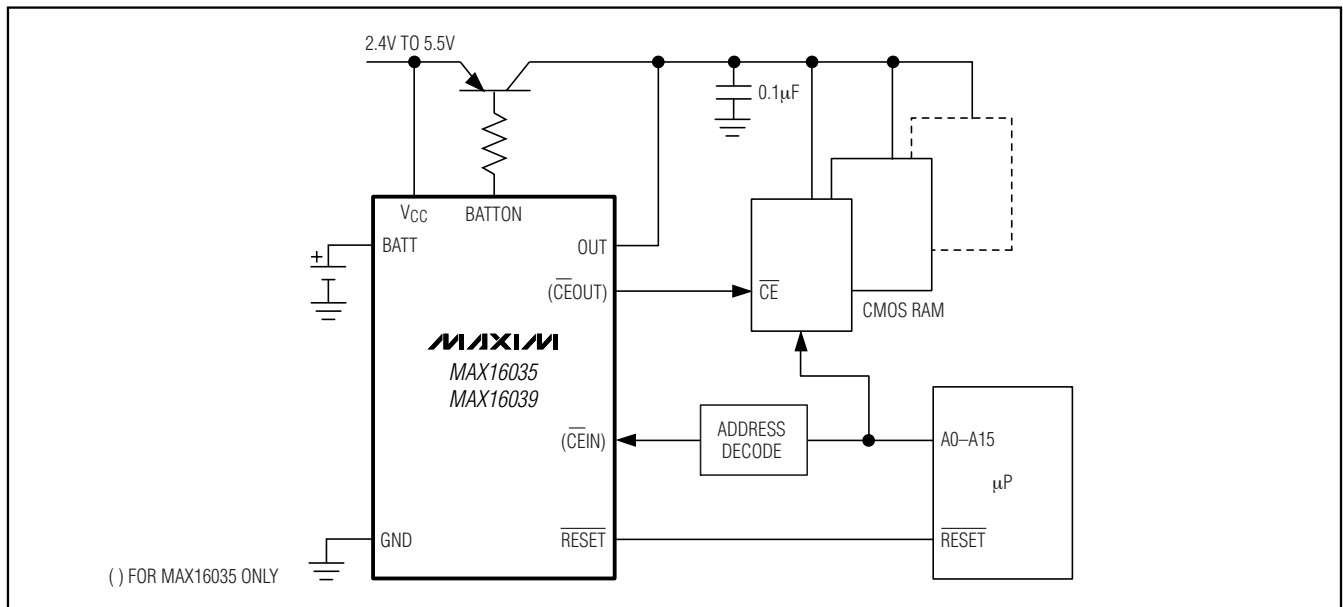

Figure 3. MAX16035/MAX16039 BATTON Driving an External Pass Transistor

# Low-Power Battery Backup Circuits in Small $\mu$ DFN Packages

## RESET

A  $\mu$ P's reset input puts the  $\mu$ P in a known state. The MAX16033–MAX16040  $\mu$ P supervisory circuits assert a reset to prevent code-execution errors during power-up, power-down, and brownout conditions. RESET asserts when  $V_{CC}$  is below the reset threshold voltage and for at least 140ms ( $t_{RP}$ ) after  $V_{CC}$  rises above the reset threshold. RESET also asserts when  $\overline{MR}$  is low (MAX16033/MAX16037) or when RESE $\overline{TIN}$  is below 1.235V (MAX16036/MAX16040). The MAX16034/MAX16038 watchdog function causes RESET to assert in pulses following a watchdog timeout (Figure 2). The MAX160\_ \_L devices provide push-pull RESET outputs. The MAX160\_ \_P devices provide open-drain RESET outputs.

## Applications Information

### Operation Without a Backup Power Source

The MAX16033–MAX16040 provide a battery backup function. If a backup power source is not used, connect BATT to GND and OUT to  $V_{CC}$ .

### Using a Super Cap as a Backup Power Source

Super caps are capacitors with extremely high capacitance, such as 0.47F. Figure 5 shows two methods to use a super cap as a backup power source. Connect the super cap through a diode to the 3V input (Figure 5a) or connect the super cap through a diode to 5V (Figure 5b) if a 5V supply is available. The 5V supply charges the super cap to a voltage close to 5V, allowing a longer backup period. Since  $V_{BATT}$  can be higher than  $V_{CC}$  while  $V_{CC}$  is above the reset threshold voltage, there are no special precautions required when using these  $\mu$ P supervisors with a super cap.

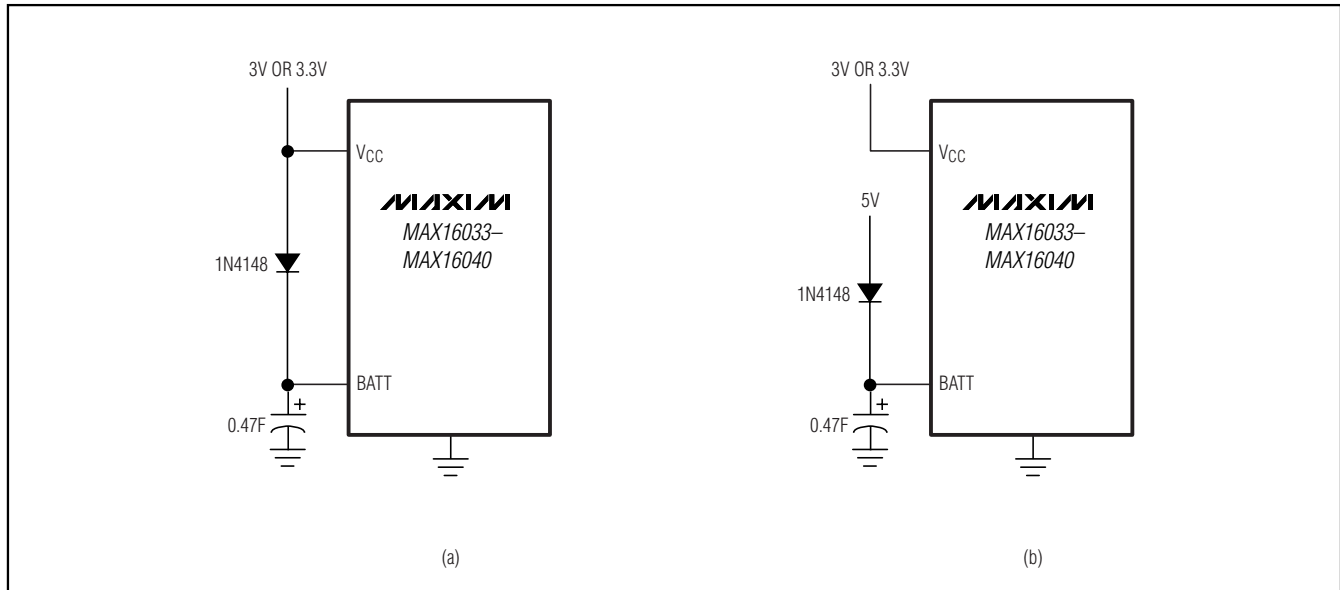

Figure 5. Using a Super Cap as a Backup Source

# Low-Power Battery Backup Circuits in Small $\mu$ DFN Packages

MAX16033-MAX16040

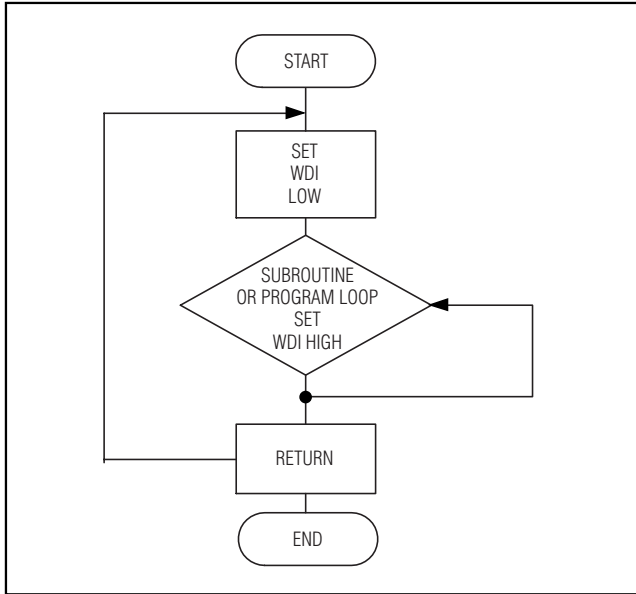

Figure 6. Watchdog Flow Diagram

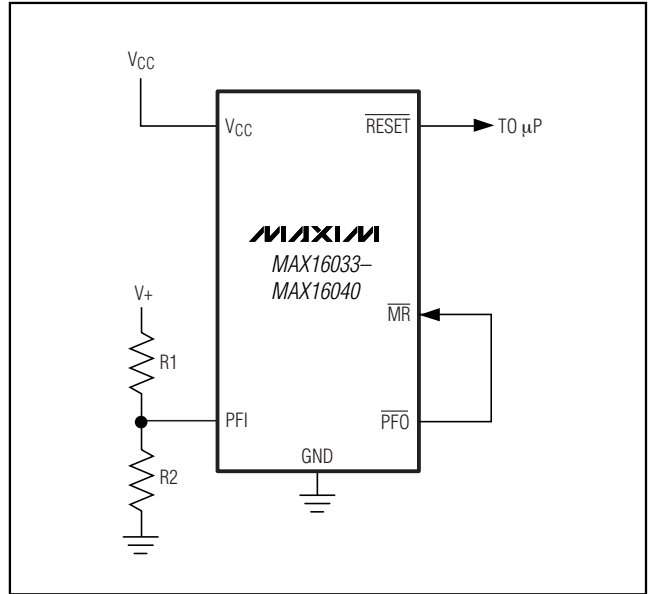

Figure 7. Monitoring an Additional Power Supply

## Watchdog Software Considerations

One way to help the watchdog timer to monitor software execution more closely is to set and reset the watchdog at different points in the program, rather than pulsing the watchdog input periodically. Figure 6 shows a flow diagram where the I/O driving the watchdog is set low in the beginning of the program, set high at the beginning of every subroutine or loop, and set low again when the program returns to the beginning. If the program should hang in any subroutine, the watchdog would timeout and reset the  $\mu$ P.

## Replacing the Backup Battery

Decouple BATT to GND with a 0.1 $\mu$ F capacitor. The backup power source may be removed while VCC remains valid without the danger of triggering a reset pulse. The device does not enter battery-backup mode when VCC stays above the reset threshold voltage.

## Power-Fail Comparator

### Monitoring an Additional Power Supply

Monitor another voltage by connecting a resistive divider to PFI as shown in Figure 7. The threshold voltage is:

$$V_{TH(PFI)} = 1.235 (R1 / R2 + 1)$$

where  $V_{TH(PFI)}$  is the threshold at which the monitored voltage will trip PFO.

To simplify the resistor selection, choose a value for R2 and calculate R1.

$$R1 = R2 [(V_{TH(PFI)} / 1.235) - 1]$$

Connect  $\overline{PFO}$  to  $\overline{MR}$  in applications that require  $\overline{RESET}$  to assert when the second voltage falls below its threshold.  $\overline{RESET}$  remains asserted as long as PFO holds MR low, and for 140ms (min) after  $\overline{PFO}$  goes high.

### Adding Hysteresis to the Power-Fail Comparator

The power-fail comparator provides a typical hysteresis of 12mV, which is sufficient for most applications where a power-supply line is being monitored through an external voltage-divider. Connect a voltage-divider between PFI and  $\overline{PFO}$  as shown in Figure 8a to provide additional noise immunity. Select the ratio of R1 and R2 such that  $V_{PFI}$  falls to 1.235V when  $V_{IN}$  drops to its trip point,  $V_{TRIP}$ . R3 adds hysteresis and is typically more than 10 times the value of R1 or R2. The hysteresis window extends above ( $V_H$ ) and below ( $V_L$ ) the original trip point,  $V_{TRIP}$ . Connecting an ordinary signal diode in series with R3 as shown in Figure 8b causes the lower trip point ( $V_L$ ) to coincide with the trip point without hysteresis ( $V_{TRIP}$ ). This method provides additional noise margin without compromising the accuracy of the power-fail threshold when the monitored voltage is falling. Set the current through R1 and R2 to be at least 10 $\mu$ A to ensure that the 100nA (max) PFI input current does not shift the trip point. Set R3 to be higher than 10k $\Omega$  to reduce the load at  $\overline{PFO}$ . Capacitor C1 adds additional noise rejection.

# Low-Power Battery Backup Circuits in Small $\mu$ DFN Packages

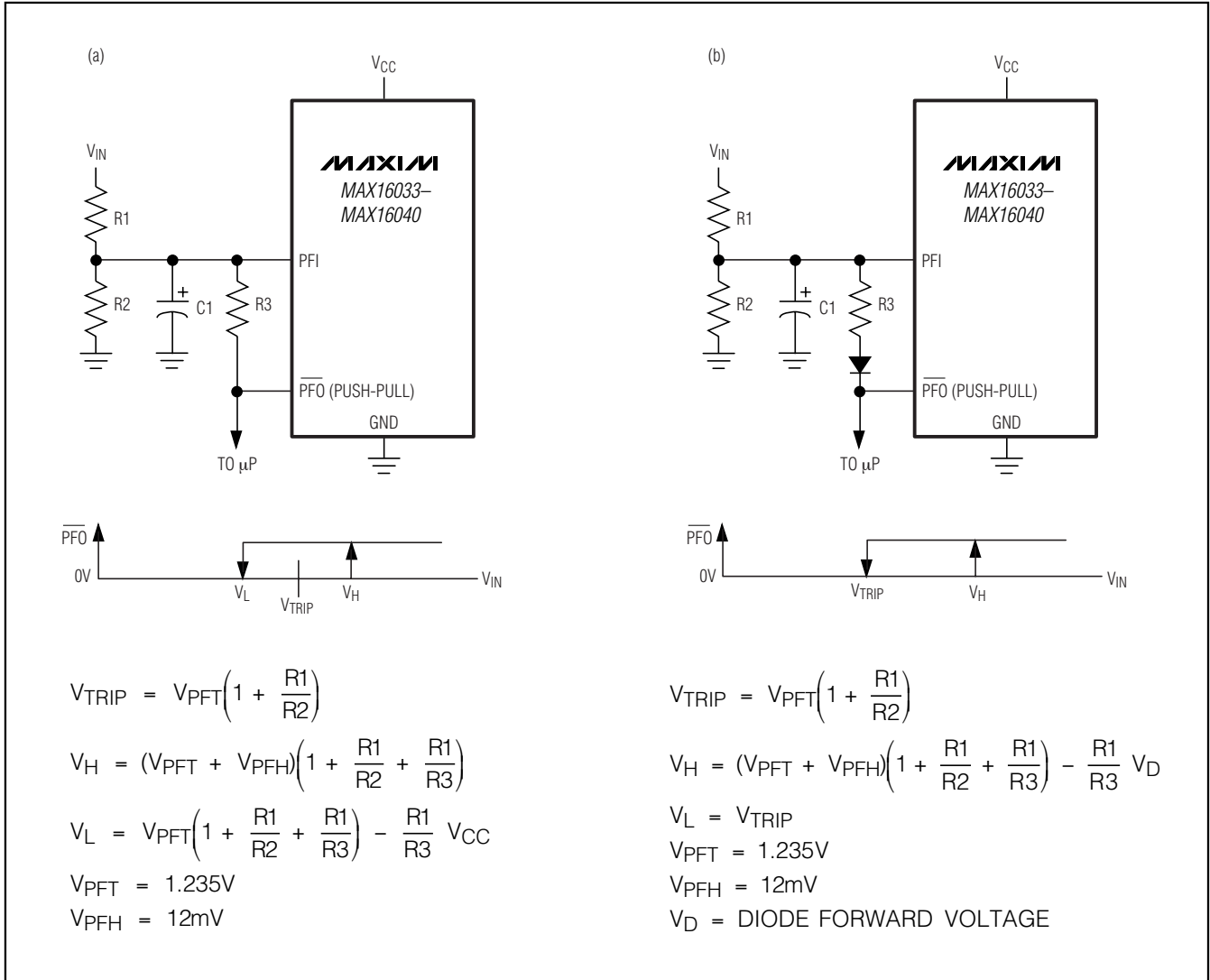

Figure 8. (a) Adding Additional Hysteresis to the Power-Fail Comparator. (b) Shifting the Additional Hysteresis above  $V_{TRIP}$

# Low-Power Battery Backup Circuits in Small $\mu$ DFN Packages

## Monitoring a Negative Voltage

Connect the circuit as shown in Figure 9 to use the power-fail comparator to monitor a negative supply rail.  $\overline{\text{PFO}}$  stays low when  $V^-$  is good. When  $V^-$  rises to cause PFI to be above +1.235V,  $\overline{\text{PFO}}$  goes high. Ensure  $V_{\text{CC}}$  comes up before the negative supply.

## Negative-Going $V_{\text{CC}}$ Transients

The MAX16033–MAX16040 are relatively immune to short-duration, negative-going  $V_{\text{CC}}$  transients. Resetting the  $\mu\text{P}$  when  $V_{\text{CC}}$  experiences only small glitches is not usually desired.

The *Typical Operating Characteristics* section contains a Maximum Transient Duration vs. Reset Threshold Overdrive graph. The graph shows the maximum pulse width of a negative-going  $V_{\text{CC}}$  transient that would not trigger a reset pulse. As the amplitude of the transient increases (i.e., goes further below the reset threshold voltage), the maximum allowable pulse width decreases. Typically, a  $V_{\text{CC}}$  transient that goes 100mV below the reset threshold and lasts for 25 $\mu\text{s}$  does not trigger a reset pulse.

A 0.1 $\mu\text{F}$  bypass capacitor mounted close to  $V_{\text{CC}}$  provides additional transient immunity.

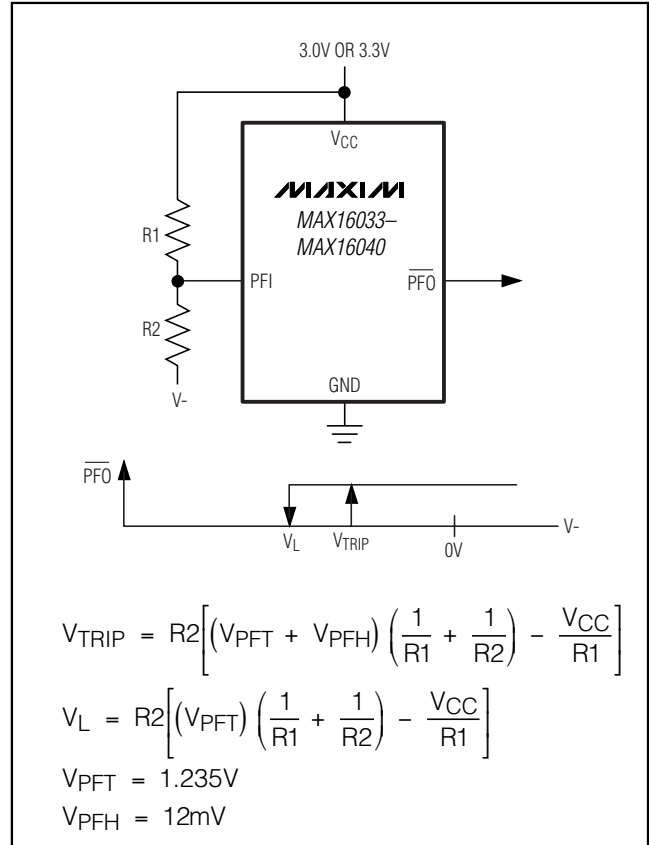

Figure 9. Monitoring a Negative Voltage

MAX16033–MAX16040

# Low-Power Battery Backup Circuits in Small $\mu$ DFN Packages

**MAX16033-MAX16040**

## Device Marking Codes

PART	TOP MARK	PART	TOP MARK	PART	TOP MARK	PART	TOP MARK
MAX16033LLB23+T	+ABE	MAX16035LLB23+T	+ACC	MAX16037LLA23+T	+ABX	MAX16039LLA23+T	+ACV
MAX16033LLB26+T	+ABF	MAX16035LLB26+T	+ACD	MAX16037LLA26+T	+ABY	MAX16039LLA26+T	+ACW
<b>MAX16033LLB29+T</b>	<b>+ABG</b>	<b>MAX16035LLB29+</b>	<b>+ACE</b>	<b>MAX16037LLA29+</b>	<b>+ABZ</b>	<b>MAX16039LLA29+T</b>	<b>+ACX</b>
<b>MAX16033LLB31+T</b>	<b>+ABH</b>	<b>MAX16035LLB31+</b>	<b>+ACF</b>	<b>MAX16037LLA31+</b>	<b>+ACA</b>	<b>MAX16039LLA31+T</b>	<b>+ACY</b>
MAX16033LLB44+T	+ABI	MAX16035LLB44+T	+ACG	MAX16037LLA44+T	+ACB	MAX16039LLA44+T	+ACZ
<b>MAX16033LLB46+T</b>	<b>+ABJ</b>	<b>MAX16035LLB46+</b>	<b>+ACH</b>	<b>MAX16037LLA46+</b>	<b>+ACC</b>	<b>MAX16039LLA46+T</b>	<b>+ADA</b>
MAX16033PLB23+T	+ABK	MAX16035PLB23+T	+ACI	MAX16037PLA23+T	+ACD	MAX16039PLA23+T	+ADB
MAX16033PLB26+T	+ABL	MAX16035PLB26+T	+ACJ	MAX16037PLA26+T	+ACE	MAX16039PLA26+T	+ADC
<b>MAX16033PLB29+</b>	<b>+ABM</b>	<b>MAX16035PLB29+</b>	<b>+ACK</b>	<b>MAX16037PLA29+</b>	<b>+ACF</b>	<b>MAX16039PLA29+</b>	<b>+ADD</b>
<b>MAX16033PLB31+</b>	<b>+ABN</b>	<b>MAX16035PLB31+</b>	<b>+ACL</b>	<b>MAX16037PLA31+</b>	<b>+ACG</b>	<b>MAX16039PLA31+</b>	<b>+ADE</b>
MAX16033PLB44+T	+ABO	MAX16035PLB44+T	+ACM	MAX16037PLA44+T	+ACH	MAX16039PLA44+T	+ADF
<b>MAX16033PLB46+</b>	<b>+ABP</b>	<b>MAX16035PLB46+</b>	<b>+ACN</b>	<b>MAX16037PLA46+</b>	<b>+ACI</b>	<b>MAX16039PLA46+</b>	<b>+ADG</b>
MAX16034LLB23+T	+ABQ	MAX16036LLB23+T	+ACO	MAX16038LLA23+T	+ACJ	MAX16040LLA23+T	+ADH
MAX16034LLB26+T	+ABR	MAX16036LLB26+T	+ACP	MAX16038LLA26+T	+ACK	MAX16040LLA26+T	+ADI
<b>MAX16034LLB29+T</b>	<b>+ABS</b>	<b>MAX16036LLB29+</b>	<b>+ACQ</b>	<b>MAX16038LLA29+</b>	<b>+ACL</b>	<b>MAX16040LLA29+T</b>	<b>+ADJ</b>
<b>MAX16034LLB31+T</b>	<b>+ABT</b>	<b>MAX16036LLB31+</b>	<b>+ACR</b>	<b>MAX16038LLA31+</b>	<b>+ACM</b>	<b>MAX16040LLA31+T</b>	<b>+ADK</b>
MAX16034LLB44+T	+ABU	MAX16036LLB44+T	+ACS	MAX16038LLA44+T	+ACN	MAX16040LLA44+T	+ADL
<b>MAX16034LLB46+T</b>	<b>+ABV</b>	<b>MAX16036LLB46+</b>	<b>+ACT</b>	<b>MAX16038LLA46+</b>	<b>+ACO</b>	<b>MAX16040LLA46+T</b>	<b>+ADM</b>
MAX16034PLB23+T	+ABW	MAX16036PLB23+T	+ACU	MAX16038PLA23+T	+ACP	MAX16040PLA23+T	+ADN
MAX16034PLB26+T	+ABX	MAX16036PLB26+T	+ACV	MAX16038PLA26+T	+ACQ	MAX16040PLA26+T	+ADO
<b>MAX16034PLB29+</b>	<b>+ABY</b>	<b>MAX16036PLB29+</b>	<b>+ACW</b>	<b>MAX16038PLA29+</b>	<b>+ACR</b>	<b>MAX16040PLA29+</b>	<b>+ADP</b>
<b>MAX16034PLB31+</b>	<b>ABZ</b>	<b>MAX16036PLB31+</b>	<b>+ACX</b>	<b>MAX16038PLA31+</b>	<b>+ACS</b>	<b>MAX16040PAL31+</b>	<b>+ADQ</b>
MAX16034PLB44+T	+ACA	MAX16036PLB44+T	+ACY	MAX16038PLA44+T	+ACT	MAX16040PLA44+T	+ADR
<b>MAX16034PLB46+</b>	<b>+ACB</b>	<b>MAX16036PLB46+</b>	<b>+ACZ</b>	<b>MAX16038PLA46+</b>	<b>+ACU</b>	<b>MAX16040PLA46+</b>	<b>+ADS</b>

**Note:** 48 standard versions shown in bold are available. Sample stock is generally held on standard versions only. Contact factory for nonstandard versions availability.



# Low-Power Battery Backup Circuits in Small $\mu$ DFN Packages

## Pin Configurations

**MAX16033-MAX16040**

TOP VIEW

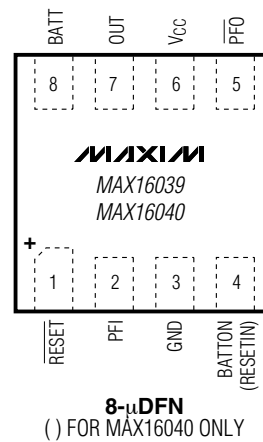
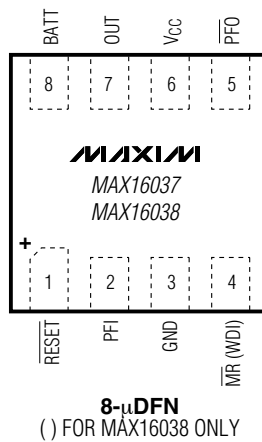
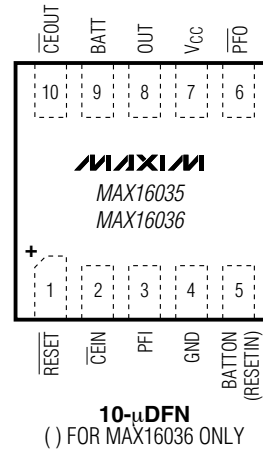
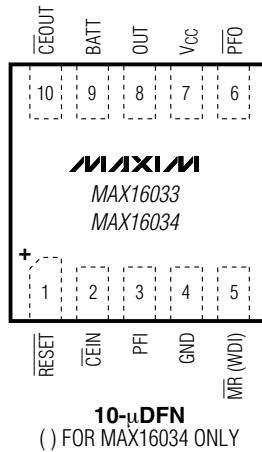

+ DENOTES A LEAD-FREE PACKAGE.

# Low-Power Battery Backup Circuits in Small $\mu$ DFN Packages

## Typical Operating Circuit

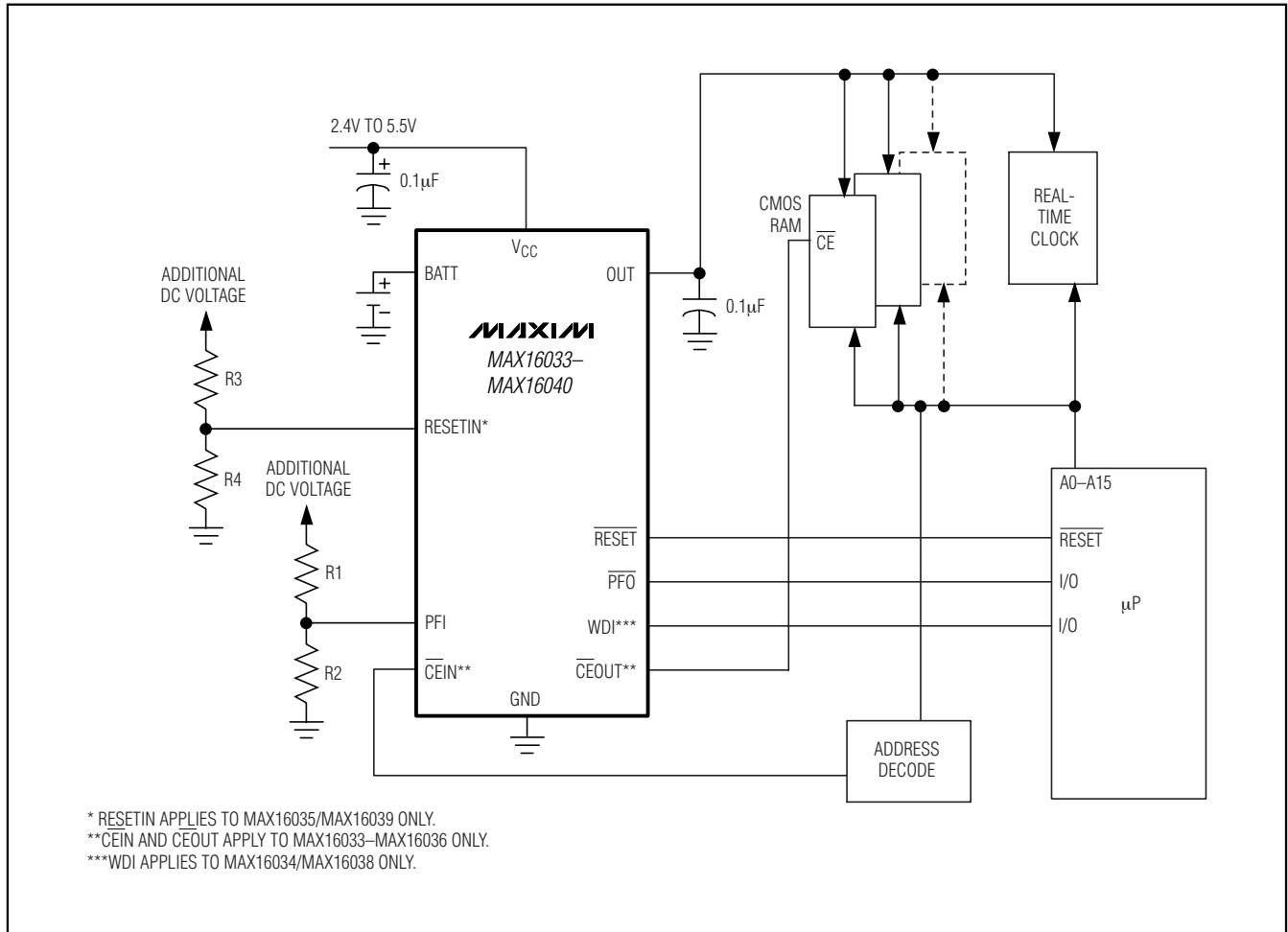

# Low-Power Battery Backup Circuits in Small $\mu$ DFN Packages

**MAX16033-MAX16040**

## Ordering Information (continued)

PART*	TEMP RANGE	PIN-PACKAGE	PKG CODE
<b>MAX16035</b> LLB_ _+T	-40°C to +85°C	10 $\mu$ DFN-10	L1022-1
MAX16035PLB_ _+T	-40°C to +85°C	10 $\mu$ DFN-10	L1022-1
<b>MAX16036</b> LLB_ _+T	-40°C to +85°C	10 $\mu$ DFN-10	L1022-1
MAX16036PLB_ _+T	-40°C to +85°C	10 $\mu$ DFN-10	L1022-1
<b>MAX16037</b> LLA_ _+T	-40°C to +85°C	8 $\mu$ DFN-8	L822-1
MAX16037PLA_ _+T	-40°C to +85°C	8 $\mu$ DFN-8	L822-1
<b>MAX16038</b> LLA_ _+T	-40°C to +85°C	8 $\mu$ DFN-8	L822-1
MAX16038PLA_ _+T	-40°C to +85°C	8 $\mu$ DFN-8	L822-1
<b>MAX16039</b> LLA_ _+T	-40°C to +85°C	8 $\mu$ DFN-8	L822-1
MAX16039PLA_ _+T	-40°C to +85°C	8 $\mu$ DFN-8	L822-1
<b>MAX16040</b> LLA_ _+T	-40°C to +85°C	8 $\mu$ DFN-8	L822-1
MAX16040PLA_ _+T	-40°C to +85°C	8 $\mu$ DFN-8	L822-1

\*These parts offer a choice of reset threshold voltages. From the Reset Threshold Ranges table, insert the desired threshold voltage code in the blank to complete the part number. See Selector Guide for a listing of device features.

+Denotes a lead-free package.

T = Tape and reel.

## Reset Threshold Ranges

SUFFIX	RESET THRESHOLD VOLTAGE (V)		
	MIN	TYP	MAX
46	4.50	4.63	4.75
44	4.25	4.38	4.50
31	3.00	3.08	3.15
29	2.85	2.93	3.00
26	2.55	2.63	2.70
23	2.25	2.32	2.38

## Chip Information

PROCESS: BiCMOS

# Low-Power Battery Backup Circuits in Small $\mu$ DFN Packages

## Package Information

(The package drawing(s) in this data sheet may not reflect the most current specifications. For the latest package outline information, go to [www.maxim-ic.com/packages](http://www.maxim-ic.com/packages).)

6, 8, 10L UDFN/EP5

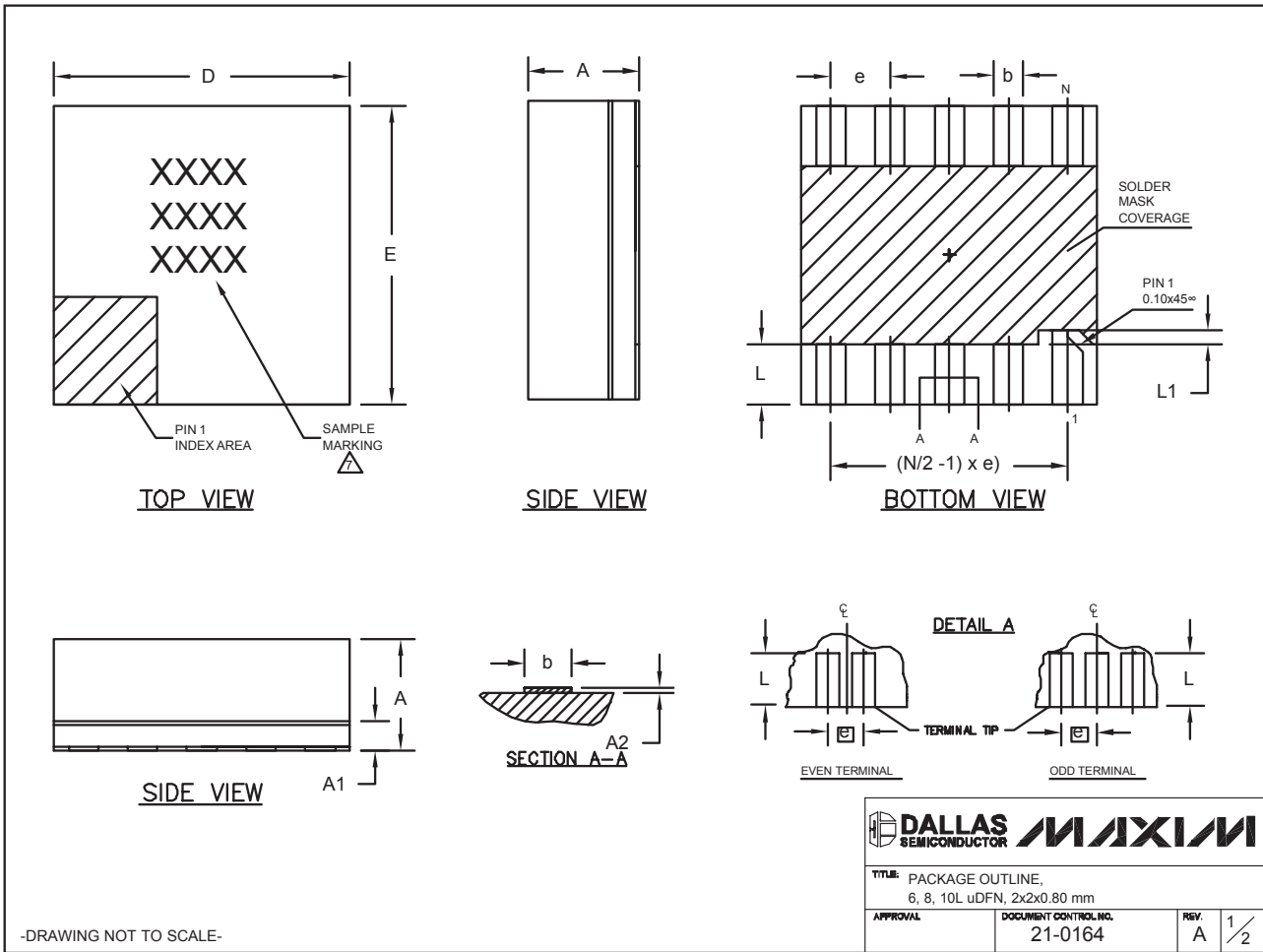

# Low-Power Battery Backup Circuits in Small $\mu$ DFN Packages

## Package Information (continued)

(The package drawing(s) in this data sheet may not reflect the most current specifications. For the latest package outline information, go to [www.maxim-ic.com/packages](http://www.maxim-ic.com/packages).)

MAX16033-MAX16040

COMMON DIMENSIONS			
SYMBOL	MIN.	NOM.	MAX.
A	0.70	0.75	0.80
A1	0.15	0.20	0.25
A2	0.020	0.025	0.035
D	1.95	2.00	2.05
E	1.95	2.00	2.05
L	0.30	0.40	0.50
L1	0.10 REF.		

PACKAGE VARIATIONS				
PKG. CODE	N	e	b	(N/2 - 1) x e
L622-1	6	0.65 BSC	0.30±0.05	1.30 REF.
L822-1	8	0.50 BSC	0.25±0.05	1.50 REF.
L1022-1	10	0.40 BSC	0.20±0.03	1.60 REF.

### NOTES:

- ALL DIMENSIONS ARE IN mm. ANGLES IN DEGREES.
- COPLANARITY SHALL NOT EXCEED 0.08mm.
- WARPAGE SHALL NOT EXCEED 0.10mm.
- PACKAGE LENGTH/PACKAGE WIDTH ARE CONSIDERED AS SPECIAL CHARACTERISTIC(S).
- "N" IS THE TOTAL NUMBER OF LEADS.
- NUMBER OF LEADS SHOWN ARE FOR REFERENCE ONLY.
-  MARKING IS FOR PACKAGE ORIENTATION REFERENCE ONLY.

-DRAWING NOT TO SCALE-

		
TITLE: PACKAGE OUTLINE, 6, 8, 10L $\mu$ DFN, 2x2x0.80 mm		
APPROVAL	DOCUMENT CONTROL NO. 21-0164	REV. A 2/2

Maxim cannot assume responsibility for use of any circuitry other than circuitry entirely embodied in a Maxim product. No circuit patent licenses are implied. Maxim reserves the right to change the circuitry and specifications without notice at any time.

Maxim Integrated Products, 120 San Gabriel Drive, Sunnyvale, CA 94086 408-737-7600 \_\_\_\_\_ 21

© 2007 Maxim Integrated Products

MAXIM is a registered trademark of Maxim Integrated Products, Inc.