

74LVXZ161284

Low Voltage IEEE 161284 Translating Transceiver with Power-Up Protection

General Description

The LVXZ161284 contains eight bidirectional data buffers and eleven control/status buffers to implement a full IEEE 1284 compliant interface. The device supports the IEEE 1284 standard and is intended to be used in an Extended Capabilities Port mode (ECP). The pinout allows for easy connection from the Peripheral (A-side) to the Host (cable side).

Outputs on the cable side can be configured to be either open drain or high drive (± 14 mA) and are connected to a separate power supply pin ($V_{CC-Cable}$) that allows these outputs to be driven by a higher supply voltage than the A-side. The pull-up and pull-down series termination resistance of these outputs on the cable side is optimized to drive an external cable. In addition, the C inputs and the B and Y outputs on the cable side contain internal pull-up resistors connected to the $V_{CC-Cable}$ supply to provide proper input termination and pull-ups for open drain output mode.

Outputs on the Peripheral side are standard low-drive CMOS outputs designed to interface with 3V logic. The DIR input controls data flow on the A_1-A_8/B_1-B_8 transceiver pins.

This device also has an added power-up protection feature which forces the Y outputs ($Y_9 - Y_{13}$) to a high state after power-on until one of the associated inputs ($A_9 - A_{13}$) goes HIGH. When an associated input ($A_9 - A_{13}$) goes HIGH, all Y outputs ($Y_9 - Y_{13}$) are activated.

Features

- Supports IEEE 1284 Level 1 and Level 2 signaling standards for bidirectional parallel communications between personal computers and printing peripherals
- Translation capability allows outputs on the cable side to interface with 5V signals
- All inputs have hysteresis to provide noise margin
- B and Y output resistance optimized to drive external cable
- B and Y outputs in high impedance mode during power down
- C inputs and B, Y outputs on cable side have internal 1.4 k Ω pull-up resistors
- Flow-through pin configuration allows easy interface between the "Peripheral and Host"
- Replaces the function of two (2) 74ACT1284 devices
- Power-up protection prevents errors when the printer is powered on but no valid signal is at the input pins ($A_9 - A_{13}$).

Ordering Code

Order Number	Package Number	Package Description
74LVXZ161284MEA	MS48A	48-Lead Small Shrink Outline Package (SSOP), JEDEC MO-118, 0.300" Wide [RAIL]
74LVXZ161284MEX	MS48A	48-Lead Small Shrink Outline Package (SSOP), JEDEC MO-118, 0.300" Wide [TAPE and REEL]
74LVXZ161284MTD	MTD48	48-Lead Thin Shrink Small Outline Package (TSSOP), JEDEC MO-153, 6.1mm Wide [RAIL]
74LVXZ161284MTX	MTD48	48-Lead Thin Shrink Small Outline Package (TSSOP), JEDEC MO-153, 6.1mm Wide [TAPE and REEL]

Logic Symbol

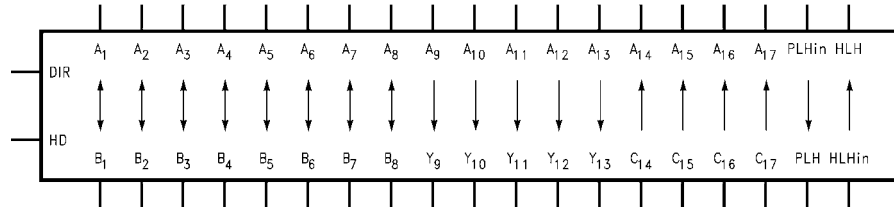

Connection Diagram

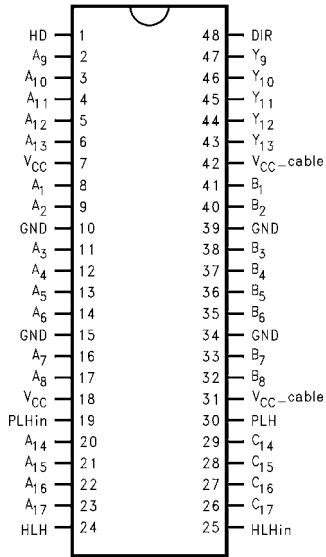

Pin Descriptions

Pin Names	Description
HD	High Drive Enable Input (Active HIGH)
DIR	Direction Control Input
A ₁ -A ₈	Inputs or Outputs
B ₁ -B ₈	Inputs or Outputs
A ₉ -A ₁₃	Inputs
Y ₉ -Y ₁₃	Outputs
A ₁₄ -A ₁₇	Outputs
C ₁₄ -C ₁₇	Inputs
PLH _{IN}	Peripheral Logic HIGH Input
PLH	Peripheral Logic HIGH Output
HLH _{IN}	Host Logic HIGH Input
HLH	Host Logic HIGH Output

Truth Table

Inputs		Outputs
DIR	HD	
L	L	B ₁ -B ₈ Data to A ₁ -A ₈ , and A ₉ -A ₁₃ Data to Y ₉ -Y ₁₃ (Note 1) C ₁₄ -C ₁₇ Data to A ₁₄ -A ₁₇ PLH Open Drain Mode
L	H	B ₁ -B ₈ Data to A ₁ -A ₈ , and A ₉ -A ₁₃ Data to Y ₉ -Y ₁₃ C ₁₄ -C ₁₇ Data to A ₁₄ -A ₁₇
H	L	A ₁ -A ₈ Data to B ₁ -B ₈ (Note 2) A ₉ -A ₁₃ Data to Y ₉ -Y ₁₃ (Note 1) C ₁₄ -C ₁₇ Data to A ₁₄ -A ₁₇ PLH Open Drain Mode
H	H	A ₁ -A ₈ Data to B ₁ -B ₈ A ₉ -A ₁₃ Data to Y ₉ -Y ₁₃ C ₁₄ -C ₁₇ Data to A ₁₄ -A ₁₇

Note 1: Y₉-Y₁₃ Open Drain Outputs with 1.4 kΩ pullups

Note 2: B₁-B₈ Open Drain Outputs with 1.4 kΩ pullups

Logic Diagrams

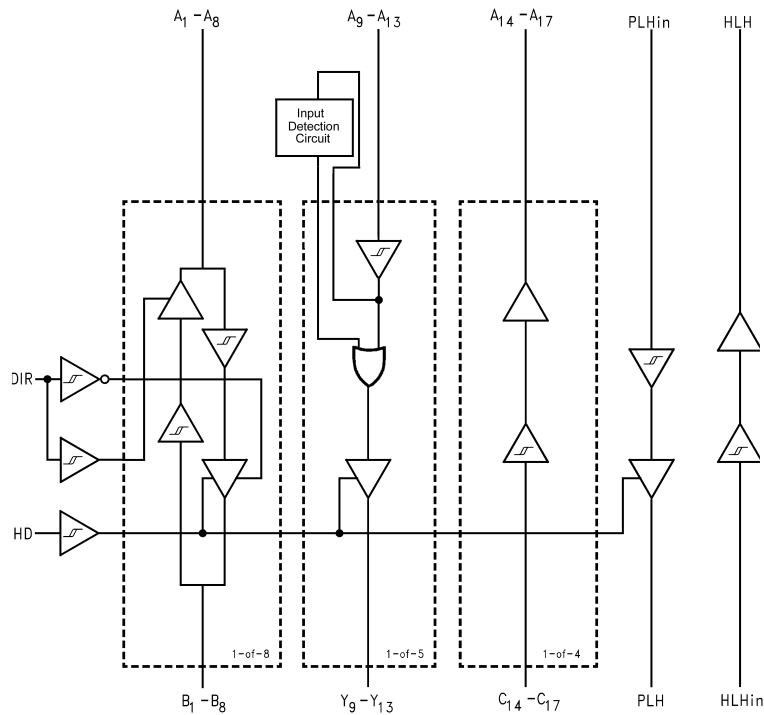

Input Detection Circuit

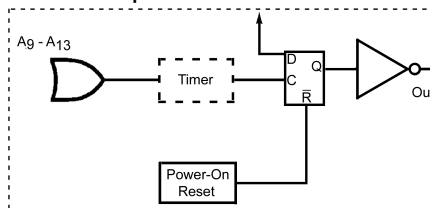

$V_{CC} = 3.3V$
 $V_{CC-Cable} = 5V$
 $T_A = 25^\circ C$
 Initial Activation Time = 140ns typical

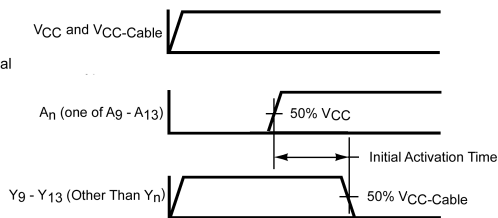

A_n (One of $A_9 - A_{13}$) is Switched as Shown Above and Other Four Inputs are Forced at Low State

FIGURE 1. Input Detection Circuit Timing

Absolute Maximum Ratings(Note 3)

Supply Voltage	
V_{CC}	-0.5V to +4.6V
V_{CC} —Cable	-0.5V to +7.0V
V_{CC} —Cable Must Be $\geq V_{CC}$	
Input Voltage (V_I)—(Note 4)	
A_1 — A_{13} , PLH_{IN} , DIR, HD	-0.5V to $V_{CC} + 0.5V$
B_1 — B_8 , C_{14} — C_{17} , HLH_{IN}	-0.5V to +5.5V (DC)
B_1 — B_8 , C_{14} — C_{17} , HLH_{IN}	-2.0V to +7.0V* *40 ns Transient
Output Voltage (V_O)	
A_1 — A_8 , A_{14} — A_{17} , HLH	-0.5V to $V_{CC} + 0.5V$
B_1 — B_8 , Y_9 — Y_{13} , PLH	-0.5V to +5.5V (DC)
B_1 — B_8 , Y_9 — Y_{13} , PLH	-2.0V to +7.0V* *40 ns Transient
DC Output Current (I_O)	
A_1 — A_8 , HLH	± 25 mA
B_1 — B_8 , Y_9 — Y_{13}	± 50 mA
PLH (Output LOW)	84 mA
PLH (Output HIGH)	-50 mA
Input Diode Current (I_{IK})—(Note 4)	
DIR, HD, A_9 — A_{13} , PLH, HLH, C_{14} — C_{17}	-20 mA
Output Diode Current (I_{OK})	
A_1 — A_8 , A_{14} — A_{17} , HLH	± 50 mA
B_1 — B_8 , Y_9 — Y_{13} , PLH	-50 mA
DC Continuous V_{CC} or Ground Current	
	± 200 mA
Storage Temperature	
	-65°C to +150°C
ESD	
Human Body Model	4000V
Machine Model	200V
Charged Device Model	2000V

Recommended Operating Conditions

Supply Voltage	
V_{CC}	3.0V to 3.6V
V_{CC} —Cable	3.0V to 5.5V
DC Input Voltage (V_I)	
	0V to V_{CC}
Open Drain Voltage (V_O)	
	0V to 5.5V
Operating Temperature (T_A)	
	-40°C to +85°C

Note 3: Absolute maximum ratings are values beyond which the device may be damaged or have its useful life impaired. Fairchild does not recommend operation outside the databook specifications.

Note 4: Either voltage limit or current limit is sufficient to protect inputs.

DC Electrical Characteristics

Symbol	Parameter		V_{CC} (V)	V_{CC} —Cable (V)	$T_A = 0^\circ\text{C}$	$T_A = -40^\circ\text{C}$	Units	Conditions
					to +70°C	to +85°C		
Guaranteed Limits								
V_{IK}	Input Clamp Diode Voltage		3.0	3.0	-1.2	-1.2	V	$I_I = -18$ mA
V_{IH}	Minimum HIGH Level Input Voltage	$A_n, B_n, PLH_{IN}, DIR, HD$	3.0–3.6	3.0–5.5	2.0	2.0	V	
		C_n	3.0–3.6	3.0–5.5	2.3	2.3		
		HLH_{IN}	3.0–3.6	3.0–5.5	2.6	2.6		
V_{IL}	Maximum LOW Level Input Voltage	$A_n, B_n, PLH_{IN}, DIR, HD$	3.0–3.6	3.0–5.5	0.8	0.8	V	
		C_n	3.0–3.6	3.0–5.5	0.8	0.8		
		HLH_{IN}	3.0–3.6	3.0–5.5	1.6	1.6		
ΔV_T	Minimum Input Hysteresis	$A_n, B_n, PLH_{IN}, DIR, HD$	3.3	5.0	0.4	0.4	V	$V_T^+ - V_T^-$
		C_n	3.3	5.0	0.8	0.8		$V_T^+ - V_T^-$
		HLH_{IN}	3.3	5.0	0.2	0.2		$V_T^+ - V_T^-$
V_{OH}	Minimum HIGH Level Output Voltage	A_n, HLH	3.0	3.0	2.8	2.8	V	$I_{OH} = -50$ μA
			3.0	3.0	2.4	2.4		$I_{OH} = -4$ mA
		B_n, Y_n	3.0	3.0	2.0	2.0		$I_{OH} = -14$ mA
		B_n, Y_n	3.0	4.5	2.23	2.23		$I_{OH} = -14$ mA
		PLH	3.15	3.15	3.1	3.1		$I_{OH} = -500$ μA

DC Electrical Characteristics (Continued)									
Symbol	Parameter		V _{CC} (V)	V _{CC-Cable} (V)	T _A = 0°C	T _A = -40°C	Units	Conditions	
					to +70°C	to +85°C			
Guaranteed Limits									
V _{OL}	Maximum LOW Level Output Voltage	A _n , HLH	3.0	3.0	0.2	0.2	V	I _{OL} = 50 μA	
			3.0	3.0	0.4	0.4		I _{OL} = 4 mA	
		B _n , Y _n	3.0	3.0	0.8	0.8		I _{OL} = 14 mA	
		B _n , Y _n	3.0	4.5	0.77	0.77		I _{OL} = 14 mA	
		PLH	3.0	3.0	0.85	0.95		I _{OL} = 84 mA	
		PLH	3.0	4.5	0.8	0.9		I _{OL} = 84 mA	
R _D	Maximum Output Impedance	B ₁ - B ₈ , Y ₉ - Y ₁₃	3.3	3.3	60	60	Ω	(Note 5)(Note 7)	
			3.3	5.0	55	55			
	Minimum Output Impedance	B ₁ - B ₈ , Y ₉ - Y ₁₃	3.3	3.3	30	30	Ω	(Note 5)(Note 7)	
			3.3	5.0	35	35			
R _P	Maximum Pull-Up Resistance	B ₁ - B ₈ , Y ₉ - Y ₁₃ , C ₁₄ - C ₁₇	3.3	3.3	1650	1650	Ω		
			3.3	5.0	1650	1650			
	Minimum Pull-Up Resistance	B ₁ - B ₈ , Y ₉ - Y ₁₃ , C ₁₄ - C ₁₇	3.3	3.3	1150	1150	Ω		
			3.3	5.0	1150	1150			
I _{IH}	Maximum Input Current in HIGH State	A ₉ - A ₁₃ , PLH _{IN} , HD, DIR, HLH _{IN}	3.6	3.6	1.0	1.0	μA	V _I = 3.6V	
		C ₁₄ - C ₁₇	3.6	3.6	50.0	50.0		V _I = 3.6V	
		C ₁₄ - C ₁₇	3.6	5.5	100	100		V _I = 5.5V	
I _{IL}	Maximum Input Current in LOW State	A ₉ - A ₁₃ , PLH _{IN} , HD, DIR, HLH _{IN}	3.6	3.6	-1.0	-1.0	μA	V _I = 0.0V	
		C ₁₄ - C ₁₇	3.6	3.6	-3.5	-3.5		mA	V _I = 0.0V
		C ₁₄ - C ₁₇	3.6	5.5	-5.0	-5.0			
I _{OZH}	Maximum Output Disable Current (HIGH)	A ₁ - A ₈	3.6	3.6	20	20	μA	V _O = 3.6V	
		B ₁ - B ₈	3.6	3.6	50	50		V _O = 3.6V	
		B ₁ - B ₈	3.6	5.5	100	100		V _O = 5.5V	
I _{OZL}	Maximum Output Disable Current (LOW)	A ₁ - A ₈	3.6	3.6	-20	-20	μA	V _O = 0.0V	
		B ₁ - B ₈	3.6	3.6	-3.5	-3.5			mA
		B ₁ - B ₈	3.6	5.5	-5.0	-5.0			
I _{OZPU}	Maximum Power-Up Disable Current	Y ₉ - Y ₁₃	0 to 1.5	0 to 1.5	350	350	μA	V _O = 5.5V	
		B ₁ - B ₈	(Note 8)	(Note 8)	-5	-5		mA	V _O = 0.0V
I _{OZPD}	Maximum Power-Down Disable Current	Y ₉ - Y ₁₃	0 to 1.5	0 to 1.5	350	350	μA	V _O = 5.5V	
		B ₁ - B ₈	(Note 8)	(Note 8)	-5	-5		mA	V _O = 0.0V
I _{OFF}	Power Down Output Leakage	B ₁ - B ₈ , Y ₉ - Y ₁₃ , PLH	0.0	0.0	100	100	μA	V _O = 5.5V	
I _{OFF}	Power Down Input Leakage	C ₁₄ -C ₁₇ , HLH _{IN}	0.0	0.0	100	100	μA	V _I = 5.5V	
I _{OFF-ICC}	Power Down Leakage to V _{CC}		0.0	0.0	250	250	μA	(Note 6)	
I _{OFF-ICC2}	Power Down Leakage to V _{CC-Cable}		0.0	0.0	250	250	μA	(Note 6)	
I _{CC}	Maximum Supply Current		3.6	3.6	45	45	mA	V _I = V _{CC} or GND	
			3.6	5.5	70	70		V _I = V _{CC} or GND	

Note 5: Output impedance is measured with the output active LOW and active HIGH (HD = HIGH).

Note 6: Power-down leakage to V_{CC} or V_{CC-Cable} is tested by simultaneously forcing all pins on the cable-side (B₁-B₈, Y₉-Y₁₃, PLH, C₁₄-C₁₇ and HLH_{IN}) to 5.5V and measuring the resulting I_{CC} or I_{CC-Cable}.

Note 7: This parameter is guaranteed but not tested, characterized only.

Note 8: Connect all V_{CC} pins and V_{CC-Cable} pins when forcing voltage applied, DIR = HD = 0V.

AC Electrical Characteristics

Symbol	Parameter	$T_A = 0^\circ\text{C to } +70^\circ\text{C}$ $V_{CC} = 3.0\text{V}-3.6\text{V}$ $V_{CC-\text{Cable}} = 3.0\text{V}-5.5\text{V}$		$T_A = -40^\circ\text{C to } +85^\circ\text{C}$ $V_{CC} = 3.0\text{V}-3.6\text{V}$ $V_{CC-\text{Cable}} = 3.0\text{V}-5.5\text{V}$		Units	Figure Number
		Min	Max	Min	Max		
		t_{PHL}	A ₁ -A ₈ to B ₁ -B ₈	2.0	40.0		
t_{PLH}	A ₁ -A ₈ to B ₁ -B ₈	2.0	40.0	2.0	44.0	ns	Figure 3
t_{PHL}	B ₁ -B ₈ to A ₁ -A ₈	2.0	40.0	2.0	44.0	ns	Figure 4
t_{PLH}	B ₁ -B ₈ to A ₁ -A ₈	2.0	40.0	2.0	44.0	ns	Figure 4
t_{PHL}	A ₉ -A ₁₃ to Y ₉ -Y ₁₃	2.0	40.0	2.0	44.0	ns	Figure 2
t_{PLH}	A ₉ -A ₁₃ to Y ₉ -Y ₁₃	2.0	40.0	2.0	44.0	ns	Figure 3
t_{PHL}	C ₁₄ -C ₁₇ to A ₁₄ -A ₁₇	2.0	40.0	2.0	44.0	ns	Figure 4
t_{PLH}	C ₁₄ -C ₁₇ to A ₁₄ -A ₁₇	2.0	40.0	2.0	44.0	ns	Figure 4
t_{SKEW}	LH-LH or HL-HL		10.0		12.0	ns	(Note 10)
t_{PHL}	PLH _{IN} to PLH	2.0	40.0	2.0	44.0	ns	Figure 2
t_{PLH}	PLH _{IN} to PLH	2.0	40.0	2.0	44.0	ns	Figure 3
t_{PHL}	HLH _{IN} to HLH	2.0	40.0	2.0	44.0	ns	Figure 4
t_{PLH}	HLH _{IN} to HLH	2.0	40.0	2.0	44.0	ns	Figure 4
t_{PHZ}	Output Disable Time	2.0	15.0	2.0	18.0	ns	Figure 8
t_{PLZ}	DIR to A ₁ -A ₈	2.0	15.0	2.0	18.0	ns	Figure 8
t_{PZH}	Output Enable Time	2.0	50.0	2.0	50.0	ns	Figure 9
t_{PZL}	DIR to A ₁ -A ₈	2.0	50.0	2.0	50.0	ns	Figure 9
t_{PHZ}	Output Disable Time	2.0	50.0	2.0	50.0	ns	Figure 10
t_{PLZ}	DIR to B ₁ -B ₈	2.0	50.0	2.0	50.0	ns	Figure 10
t_{PEN}	Output Enable Time	2.0	25.0	2.0	28.0	ns	Figure 3
	HD to B ₁ -B ₈ , Y ₉ -Y ₁₃	2.0	25.0	2.0	28.0	ns	Figure 3
t_{pDIS}	Output Disable Time	2.0	25.0	2.0	28.0	ns	Figure 3
	HD to B ₁ -B ₈ , Y ₉ -Y ₁₃	2.0	25.0	2.0	28.0	ns	Figure 3
$t_{PEN}-t_{pDIS}$	Output Enable- Output Disable		10.0		12.0	ns	
t_{SLEW}	Output Slew Rate						
t_{PLH}	B ₁ -B ₈ , Y ₉ -Y ₁₃	0.05	0.40	0.05	0.40	V/ns	Figure 6
t_{PHL}		0.05	0.40	0.05	0.40		Figure 5
t_r, t_f	t_{RISE} and t_{FALL} B ₁ -B ₈ (Note 9), Y ₉ -Y ₁₃ (Note 9)		120		120	ns	Figure 7 (Note 11)
			120		120		

Note 9: Open Drain

Note 10: t_{SKEW} is measured for common edge output transitions and compares the measured propagation delay for a given path type:

- (i) A₁-A₈ to B₁-B₈, A₉-A₁₃ to Y₉-Y₁₃
- (ii) B₁-B₈ to A₁-A₈
- (iii) C₁₄-C₁₇ to A₁₄-A₁₇

Note 11: This parameter is guaranteed but not tested, characterized only.

Capacitance

Symbol	Parameter	Typ	Units	Conditions
C_{IN}	Input Capacitance	3	pF	$V_{CC} = 0.0\text{V}$ (HD, DIR, A ₉ -A ₁₃ , C ₁₄ -C ₁₇ , PLH _{IN} and HLH _{IN})
$C_{I/O}$ (Note 12)	I/O Pin Capacitance	5	pF	$V_{CC} = 3.3\text{V}$

Note 12: $C_{I/O}$ is measured at frequency = 1 MHz, per MIL-STD-883B, Method 3012

AC Loading and Waveforms

Pulse Generator for all pulses: Rate ≤ 1.0 MHz; $Z_O \leq 50\Omega$; $t_f \leq 2.5$ ns, $t_r \leq 2.5$ ns.

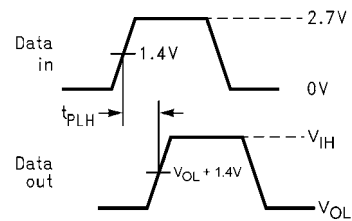
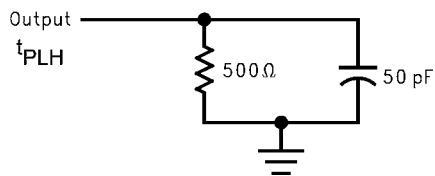
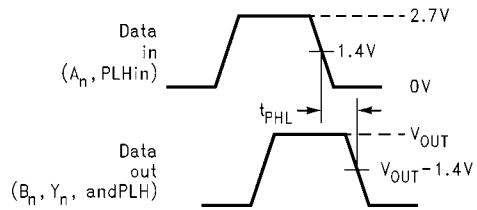
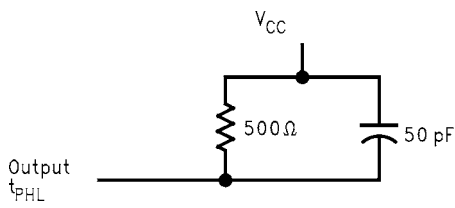

FIGURE 2. Port A to B and A to Y Propagation Delay Waveforms

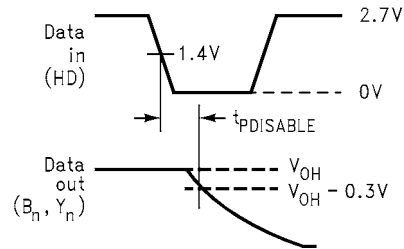
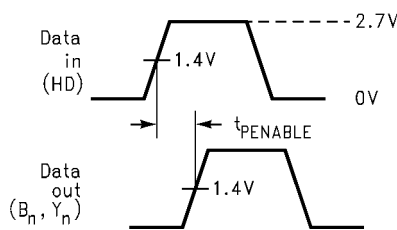

FIGURE 3. Port A to B and A to Y Output Waveforms

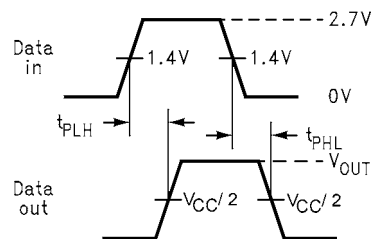
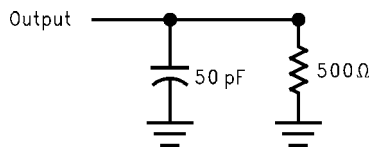

FIGURE 4. Port B to A, C to A and HLH Propagation Delay Waveforms

AC Loading and Waveforms (Continued)

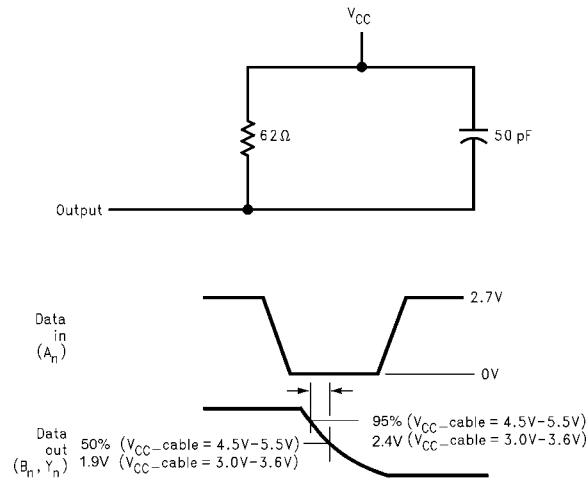

FIGURE 5. Port A to B and A to Y HL Slew Test Load and Waveforms

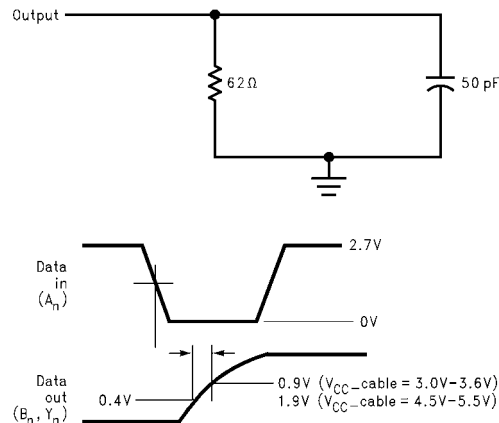

FIGURE 6. Port A to B and A to Y LH Slew Test Load and Waveforms

AC Loading and Waveforms (Continued)

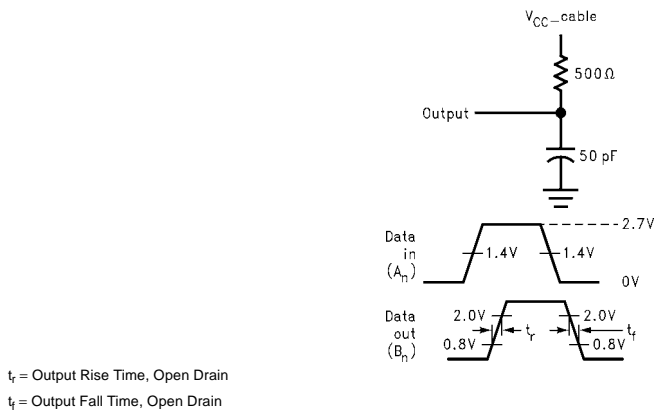

FIGURE 7. Ports A to B and A to Y Rise and Fall Test Load and Waveforms for Open Drain Outputs

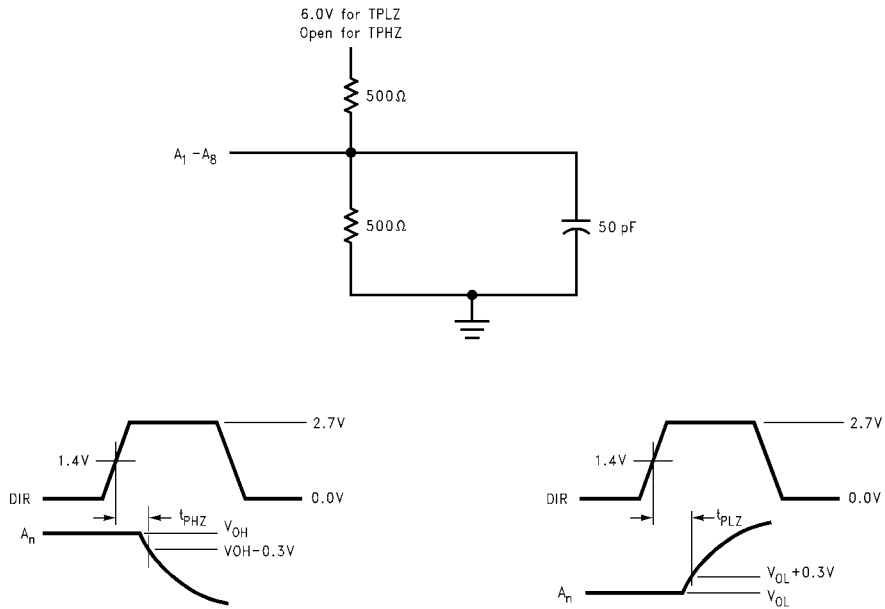

FIGURE 8. t_{pHZ} and t_{pLZ} Test Load and Waveforms, DIR to A₁-A₈

AC Loading and Waveforms (Continued)

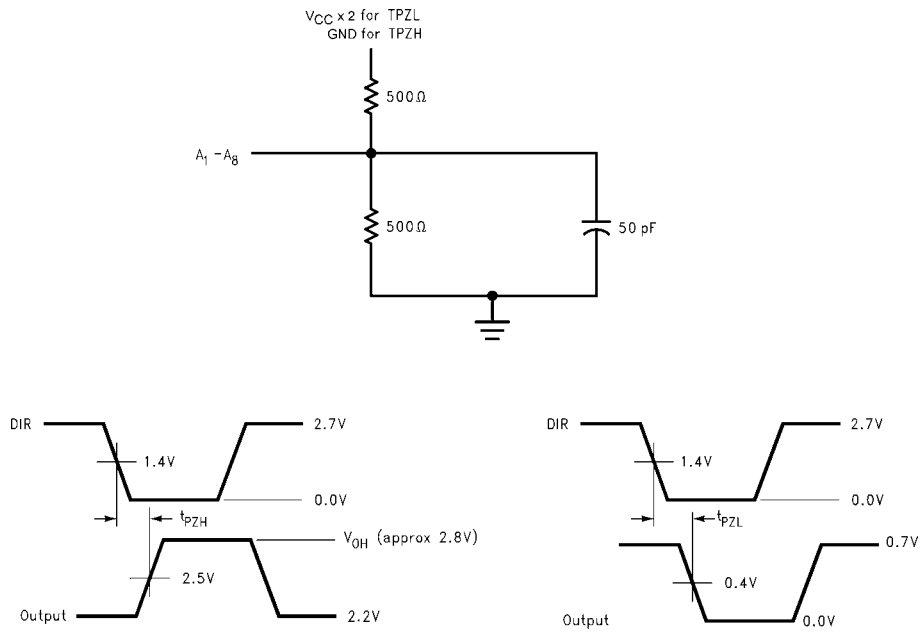

FIGURE 9. t_{PZH} and t_{PZL} Test Load and Waveforms, DIR to $A_1 - A_8$

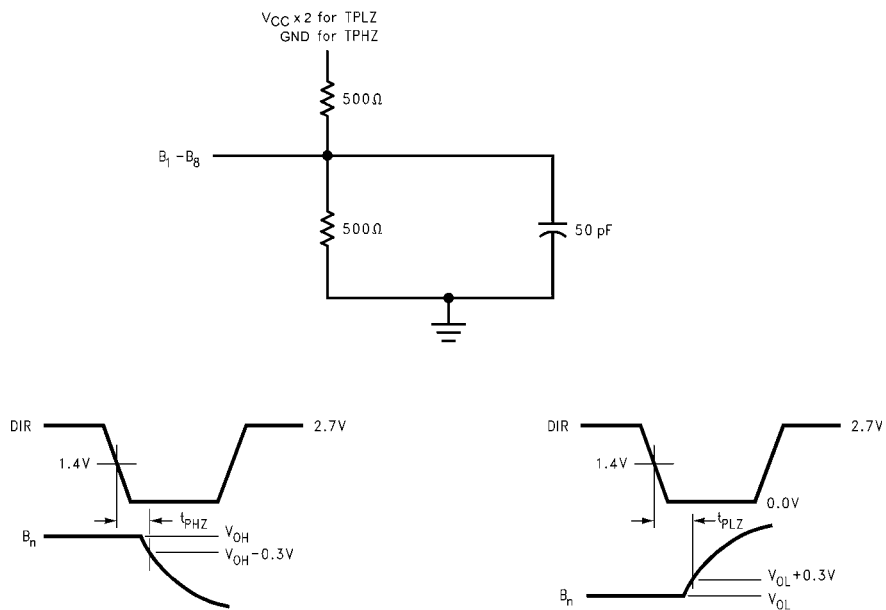
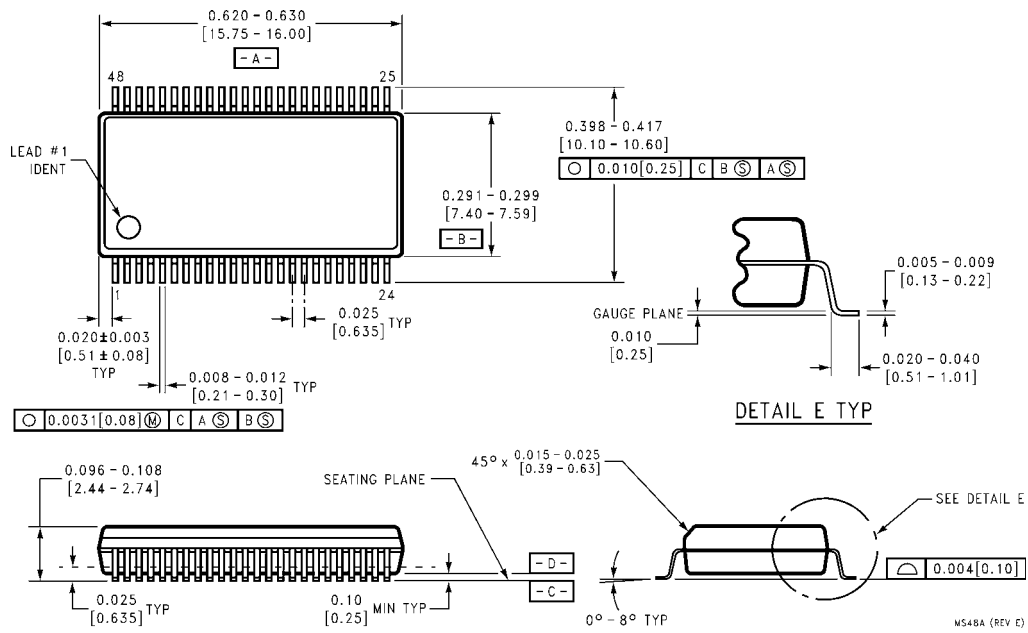

FIGURE 10. t_{PHZ} and t_{PLZ} Test Load and Waveforms DIR to $B_1 - B_8$

Physical Dimensions inches (millimeters) unless otherwise noted



**48-Lead Small Shrink Outline Package (SSOP), JEDEC MO-118, 0.300" Wide
Package Number MS48A**