



Description

The SE5508 series of fixed output low dropout linear regulators are designed for portable battery powered applications, which require low noise environment, fast enable response time, and low dropout voltage. An optional bypass capacitor can be added for better low-noise performance. Each device contains a voltage reference unit, an error amplifier, a PMOS power transistor, and resistors for setting output voltage, and current limit and temperature limit protection circuits.

The SE5508 has been designed to be used with low cost capacitors and requires a minimum output capacitor of 1.0 μ F. Standard voltage versions are 1.5, 1.8, 2.5, 2.8, 3.0, and 3.3V.

Pin Configuration

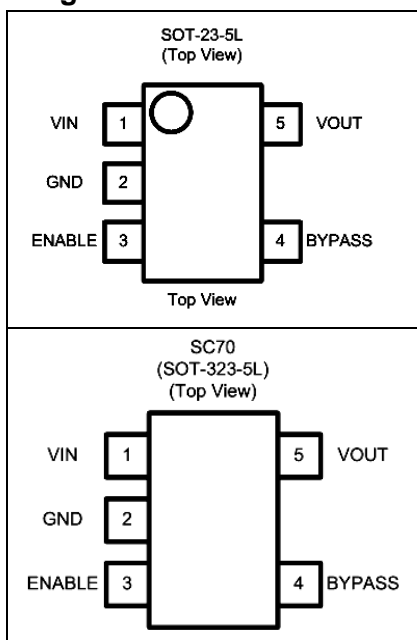

Features

- Excellent Noise Rejection at 62 dB.
- Typical Low Dropout Voltage of 200mV at 75mA.
- Fast Enable Turn-On Time of 20 μ s (Typ.)
- Excellent Line and Load Regulation.
- High Accuracy Output Voltage of 2%.
- Typical Low Ground Current at 50 μ A
- Typical Disable Current Less than 0.1 μ A
- Thermal Protection.
- Standard SOT23-5L and SC70 (SOT353) Package.
- Available in Lead-Free Packages.

Applications

- Cellphones.
- Wireless LAN's.
- Hand-Held Instrumentation.
- Portable Video Game Devices.
- Digital Cameras.

Application Diagram

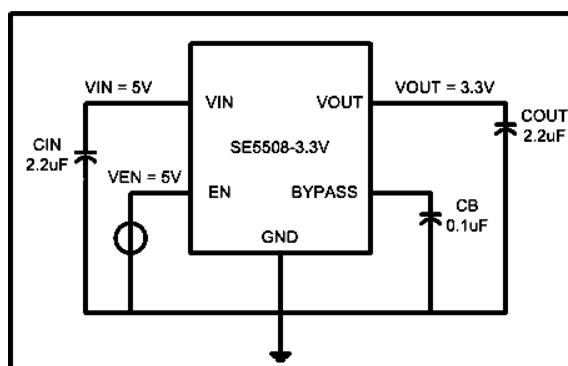



Ordering/Marking Information

Package	Ordering Information		Marking Information	
<p>SOT-23-5L (Top View)</p>	3.3V	SE5508ALG	508ALz	<p>Starting with 5, a bar on top of 5 is for production year 2001, and underlined 5 is for year 2002. The next character is marked on top for 2003, and underlined for 2004. The naming pattern continues with consecutive characters for later years.</p> <p>The last character is the week code. (A-Z: 1-26, a-z: 27-52)</p>
	2.8V	SE5508BLG	508BLz	
	2.5V	SE5508CLG	508CLz	
	1.8V	SE5508DLG	508DLz	
	1.5V	SE5508ELG	508ELz	
	3.0V	SE5508FLG	508FLz	
<p>SC70 (SOT-323-5L) (Top View)</p>	3.3V	SE5508APG	8AP	
	2.8V	SE5508BPG	8BP	
	2.5V	SE5508CPG	8CP	
	1.8V	SE5508DPG	8DP	
	1.5V	SE5508EPG	8EP	
	3.0V	SE5508FPG	8FP	

Block Diagram

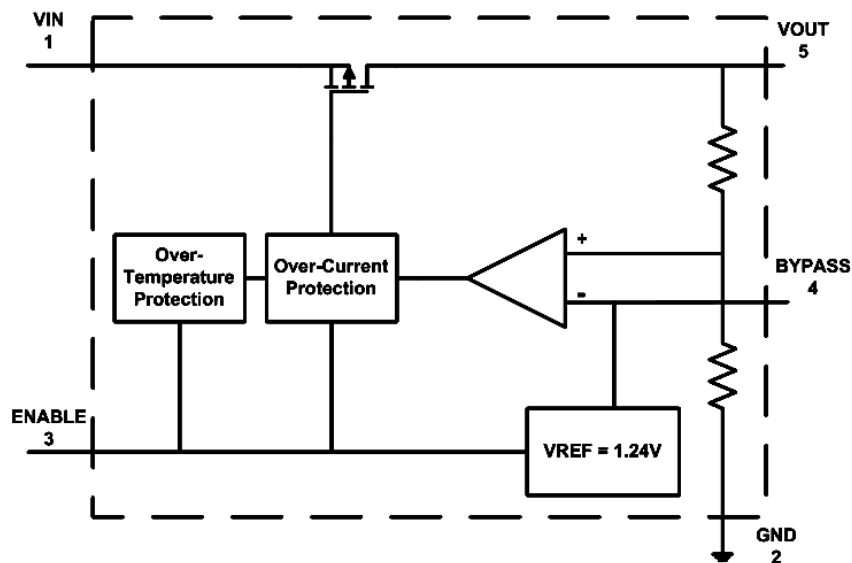



Absolute Maximum Rating ⁽¹⁾

Parameter	Symbol	Value	Units
Input Voltage	V_{IN}	6	V
Enable Voltage	V_{EN}	-0.3 to V_{IN}	V
Output Voltage	V_{OUT}	-0.3 to V_{IN}	V
Power Dissipation	P_D	Internally Limited ⁽³⁾	
Output Short Circuit Duration		Infinite	
Thermal Resistance, Junction-to-Ambient	Θ_{JA}	230	°C/W
Lead Temperature (Soldering, 5 sec.)		260	°C
Junction Temperature	T_J	0 to +150	°C
Storage Temperature	T_S	-40 to +150	°C

Operating Rating ⁽²⁾

Parameter	Symbol	Value	Units
Supply Input Voltage	V_{IN}	+2.0V to +5.5	V
Junction Temperature	T_J	0 to +125	°C

Electrical Characteristics

$V_{IN} = 5V$; $C_{IN} = 2.2\mu F$; $C_{OUT} = 2.21\mu F$; $I_{OUT} = 10mA$; $T_J = 25^\circ C$; unless otherwise noted

Symbol	Parameter	Conditions	Min	Typ	Max	Unit
V_{OUT}	Output Voltage Accuracy	SE5508 – 1.5	1.470	1.5	1.530	V
		SE5508 – 1.8	1.764	1.8	1.836	
		SE5508 – 2.5	2.450	2.5	2.550	
		SE5508 – 2.8	2.744	2.8	2.856	
		SE5508 – 3.0	2.940	3.0	3.060	
		SE5508 – 3.3	3.234	3.3	3.366	
ΔV_{OUT}	Line Regulation	$V_{IN} = V_{OUT} + 1V$ to 6V, $I_{OUT} = 10mA$ ($V_{OUT} = 3.3V$)	--	1	--	%/V
ΔV_{OUT}	Load Regulation ⁽⁵⁾	$V_{IN} = 5V$; $I_{OUT} = 10mA$ to 150mA ($V_{OUT} = 3.3V$)	--	1	--	%
$\Delta V_{OUT}/\Delta T$	Output Voltage Temperature Coefficient	Note 4	--	0.033	--	mV/°C



Electrical Characteristics (Continued)

$V_{IN} = 5V$; $C_{IN} = 2.2\mu F$; $C_{OUT} = 2.2\mu F$; $I_{OUT} = 10mA$; $T_J = 25^\circ C$; unless otherwise noted

Symbol	Parameter	Conditions	Min	Typ	Max	Unit
$V_{IN} - V_{OUT}$	Dropout Voltage ⁽⁶⁾	$I_{OUT} = 10mA$	--	20	--	mV
		$I_{OUT} = 75mA$	--	200	--	
		$I_{OUT} = 150mA$	--	500	--	
$T_{PROTECTION}$	Thermal Protection	Thermal Protection Temperature	--	150	--	$^\circ C$
		Protection Hysterisys	--	20	--	
PSRR	Ripple Rejection	$f = 120 Hz$	--	62	--	dB
I_Q	Quiescent Current	$V_{EN} = 0V$ ($V_{OUT} = 1.5V$)	--	0.1	--	μA
		$V_{EN} = V_{TH(EN)}$; $I_{OUT} = 10mA$ ($V_{OUT} = 1.5V$)	--	50	--	
$V_{TH(EN)}$	Enable Input Threshold Voltage	Voltage Increasing, Output Turns On, Logic High	1.6	--	--	V
		Voltage Decreasing, Output Turns Off, Logic Low	--	--	0.4	
I_{LIMIT}	Current Limit		300	--	--	mA

Note 1: Exceeding the absolute maximum rating may damage the device.

Note 2: The device is not guaranteed to function outside its operating rating.

Note 3: The maximum allowable power dissipation at any T_A (ambient temperature) is calculated using: $P_{D(MAX)} = (T_{J(MAX)} - T_A)/\theta_{JA}$. Exceeding the maximum allowable power dissipation will result in excessive die temperature, and the regulator will go into thermal shutdown. See "Thermal Consideration" section for details

Note 4: Output voltage temperature coefficient is the worst case voltage change divided by the total temperature range.

Note 5: Regulation is measured at constant junction temperature using low duty cycle pulse testing. Parts are tested for load regulation in the load range from 0.1mA to 150mA. Changes in output voltage due to heating effects are covered by the thermal regulation specification.

Note 6: Dropout voltage is defined as the input to output differential at which the output voltage drops 2% below its nominal value measured at 1V differential.



Line Regulation (VOUT = 3.3V)

(VIN = 4.3V to 5V, IOU = 10mA)

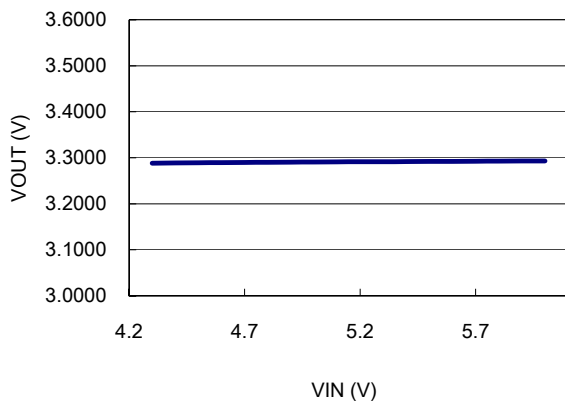

Load Regulation (VOUT = 3.3V)

(VIN = 5V, IOU = 10mA to 150mA)

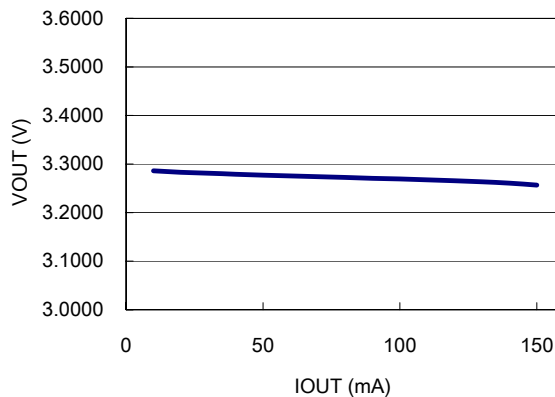

Output Voltage vs Temperature

(VIN = 3.3V, IOU = 10mA)

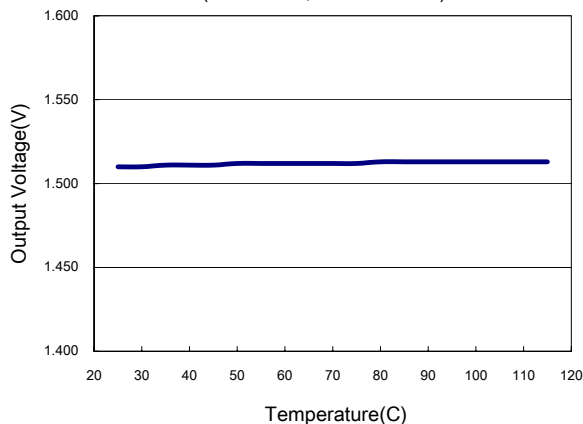

IQ vs IOU (VOUT = 1.5V)

(VIN = 3.3V, IOU = 10mA to 150mA)

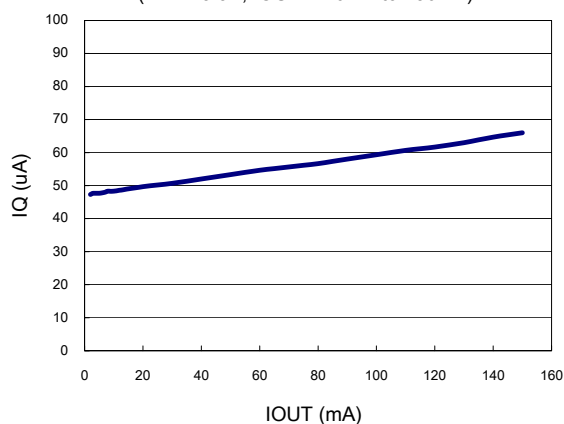

PSRR (VOUT = 3.3V)

(VIN = 5V, VPP = 1V)

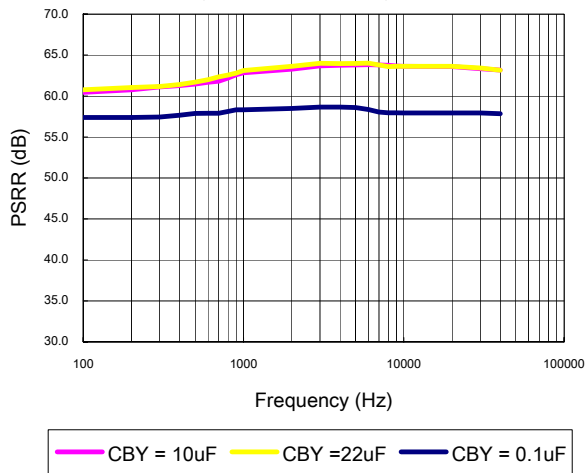

Transient Response (VOUT = 3.3V)

(IOU = 1mA to 40mA)

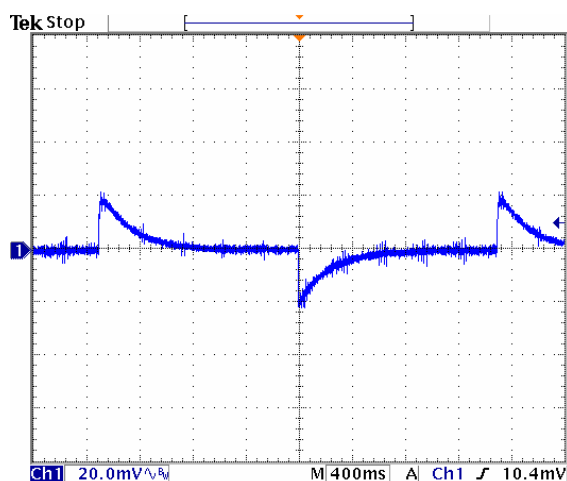

Application Hints

Like any low dropout regulator, SE5508 requires external capacitors to ensure stability. The external capacitors must be carefully selected to ensure performance.

Input Capacitor

An input capacitor of at least 1 μ F is required. Ceramic or Tantalum can be used. The value can be increased without upper limit.

Output Capacitor

An output capacitor is required for stability. It must be placed no more than 1 cm away from the V_{OUT} pin, and connected directly between V_{OUT} and GND pins. The minimum value is 1 μ F but may be increased without limit.

Thermal Considerations

It is important that the thermal limit of the package is not exceeded. The SE5508 has built-in thermal protection. When the thermal limit is exceeded, the IC will enter protection, and V_{OUT} will be pulled to ground. The power dissipation for a given application can be calculated as following:

The power dissipation (P_D) is

$$P_D = I_{OUT} * [V_{IN} - V_{OUT}]$$

The thermal limit of the package is then limited to $P_{D(MAX)} = [T_J - T_A]/\Theta_{JA}$ where T_J is the junction temperature, T_A is the ambient temperature, and Θ_{JA} is around 230°C/W for SE5508. SE5508 is designed to enter thermal protection at 150°C. For example, if T_A is 25°C then the maximum P_D is limited to about 0.6W. In other words, if $I_{OUT(MAX)} = 150\text{mA}$, then $[V_{IN} - V_{OUT}]$ cannot exceed 3.6V.



OUTLINE DRAWING SOT-23-5L

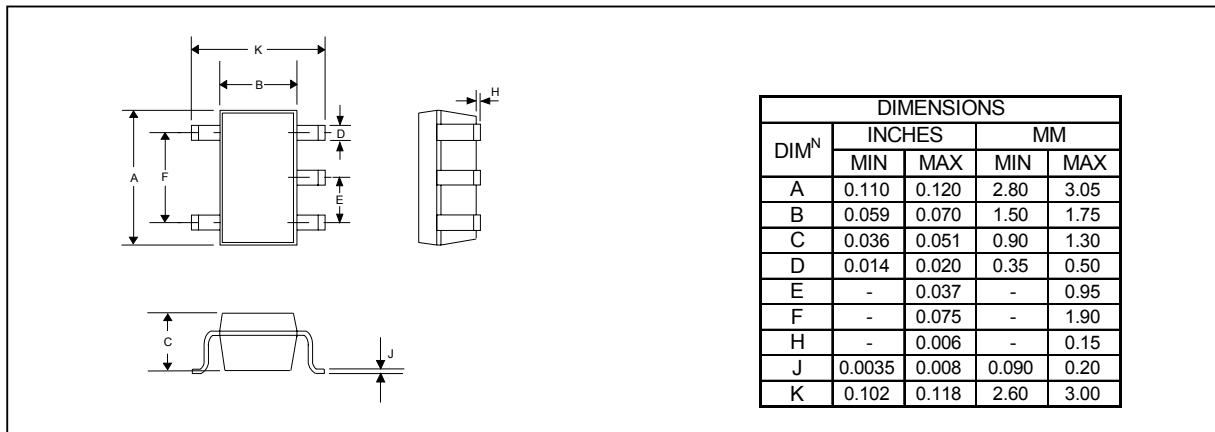

OUTLINE DRAWING SC70 (SOT353)

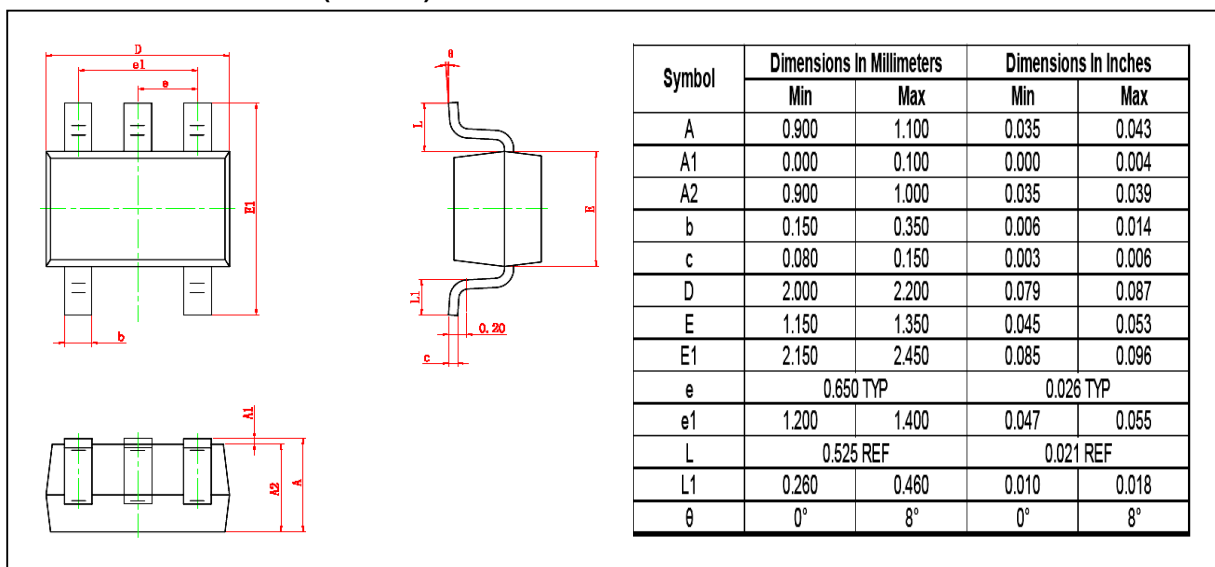



Customer Support

Seaward Electronics Incorporated – China

Rm 1605, Building 1, International Pioneering Park, #1 Shangdi Xinxu Rd
Haidian District, Beijing 100085, China
Tel: 86-10-8289-5700/01/05
Fax: 86-10-8289-5706

Seaward Electronics Corporation – Taiwan

2F, #181, Sec. 3, Minguan East Rd,
Taipei, Taiwan R.O.C
Tel: 886-2-2712-0307
Fax: 886-2-2712-0191

Seaward Electronics Incorporated – North America

49 Showers Dr. J126
Mountain View, CA 94040, USA
Tel: 1-408-821-6600

Last Updated - 5/25/2005