



## Description

The SE5509B series of fixed output low dropout linear regulators are designed for portable battery powered applications, which require low power consumption, low noise environment, and low dropout voltage. Each device contains a bandgap voltage reference, an error amplifier, a PMOS power transistor, and resistors for setting output voltage, and current limit and temperature limit protection circuits.

The SE5509B has been designed to be used with low cost capacitors and requires a minimum output capacitor of 1.0 $\mu$ F. The output voltages range from 1.3V to 4.4V in 100mV increments. Standard voltage versions are 1.5, 1.8, 2.5, 2.8, 3.0, and 3.3V.

## Pin Configuration

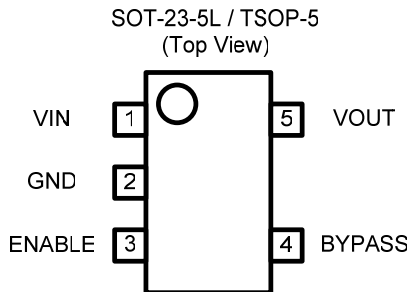

## Block Diagram

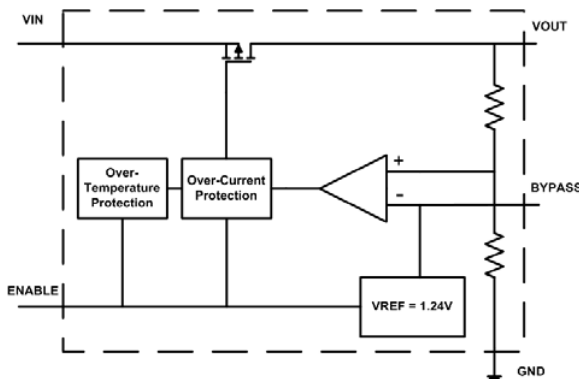

## Features

- Typical 110mV Dropout Voltage at 150mA.
- Fast Enable Turn-On Time of 20 $\mu$ s (Typ.)
- Excellent Line and Load Regulation.
- High Accuracy Output Voltage of 2%.
- Ultra-Low Ground Current at 35 $\mu$ A (Typ.)
- Disable Current Less than 0.01 $\mu$ A (Typ.)
- Over Current and thermal Protection.
- No Reverse Current.
- Standard SOT-23-5L and TSOP-5 Package.
- 100% Lead (Pb)-Free

## Application

- USB removable devices
- MPEG4 devices
- Wireless LAN's
- Hand-Held Instrumentation.
- Portable DVD players
- Digital camera

## Ordering Information

SE5509B

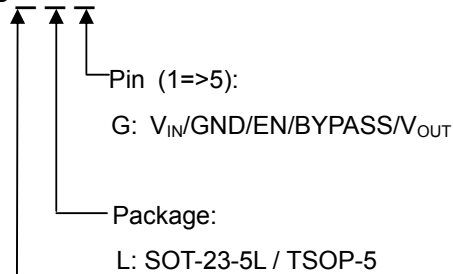

Output Voltage: A: V<sub>OUT</sub> = 3.3V

B: V<sub>OUT</sub> = 2.8V

C: V<sub>OUT</sub> = 2.5V

D: V<sub>OUT</sub> = 1.8V

E: V<sub>OUT</sub> = 1.5V

F: V<sub>OUT</sub> = 3.0V



**Ordering/Marking Information**

Package	Ordering Information		Marking Information	
<p>SOT-23-5L / TSOP-5 (Top View)</p> <p>VIN 1 5 VOUT GND 2 ENABLE 3 4 BYPASS</p>	3.3V	SE5509BALG-LF	509ALz <sup>●</sup>	The last character is the batch number. A dot on top right corner is for lead-free process. LF: lead free.
	2.8V	SE5509BBLG-LF	509BLz <sup>●</sup>	
	2.5V	SE5509BCLG-LF	509CLz <sup>●</sup>	
	1.8V	SE5509BDLG-LF	509DLz <sup>●</sup>	
	1.5V	SE5509BELG-LF	509ELz <sup>●</sup>	
	3.0V	SE5509BFLG-LF	509FLz <sup>●</sup>	

**Absolute Maximum Rating <sup>(1)</sup>**

Parameter	Symbol	Value	Units
Input Voltage	$V_{IN}$	6	V
Enable Voltage	$V_{EN}$	-0.3 to $V_{IN}$	V
Output Voltage	$V_{OUT}$	-0.3 to 4.6	V
Power Dissipation	$P_D$	Internally Limited <sup>(3)</sup>	
Output Short Circuit Duration		Infinite	
Thermal Resistance, Junction-to-Ambient	$\Theta_{JA}$	230	°C/W
Lead Temperature (Soldering, 5 sec.)		260	°C
Junction Temperature	$T_J$	0 to +150	°C
Storage Temperature	$T_S$	-40 to +150	°C

**Operating Rating <sup>(2)</sup>**

Parameter	Symbol	Value	Units
Supply Input Voltage Range	$V_{IN}$	5.5	V
Junction Temperature Range	$T_J$	0 to +125	°C

**Electrical Characteristics**

$V_{IN} = 5V$ ;  $V_{EN} = V_{IN}$ ;  $C_{IN} = 2.2\mu F$ ;  $C_{OUT} = 2.2\mu F$  (Electrolytic capacitor) ;  $I_{OUT} = 10mA$ ;  $T_J = 25^\circ C$ ; unless otherwise noted

Symbol	Parameter	Conditions	Min	Typ	Max	Unit
$V_{OUT}$	Output Voltage Accuracy	SE5509B – 1.5 ( $V_{IN} = 1.8V$ )	1.455	1.5	1.545	V
		SE5509B – 1.8 ( $V_{IN} = 3.3V$ )	1.764	1.8	1.836	
		SE5509B – 2.5	2.450	2.5	2.550	
		SE5509B – 2.8	2.744	2.8	2.856	
		SE5509B – 3.0	2.940	3.0	3.060	
		SE5509B – 3.3	3.234	3.3	3.366	
$\Delta V_{OUT}$	Line Regulation	$V_{IN} = (V_{OUT} + 0.8)V$ to 5.5V	--	0.2	--	%/V
$\Delta V_{OUT}$	Load Regulation <sup>(5)</sup>	$V_{IN} = (V_{OUT} + 0.8)V$ or 2.5V $I_{OUT} = 10mA$ to 300mA	--	1.0	--	%



**Electrical Characteristics (Continued)**

$V_{IN} = 5V$ ;  $C_{IN} = 2.2\mu F$ ;  $C_{OUT} = 2.2\mu F$  (Electrolytic capacitor) ;  $I_{OUT} = 10mA$ ;  $T_J = 25^{\circ}C$ ; unless otherwise noted

Symbol	Parameter	Conditions	Min	Typ	Max	Unit
$\Delta V_{OUT}/\Delta T$	Output Voltage Temperature Coefficient	Note 4	--	0.1	--	mV/ $^{\circ}C$
$V_{IN} - V_{OUT}$	Dropout Voltage <sup>(6)</sup> ( $V_{OUT} > 3.0V$ )	$I_{OUT} = 10mA$	--	8	--	mV
		$I_{OUT} = 150mA$	--	110	--	
		$I_{OUT} = 300mA$	--	250	--	
$T_{PROTECTION}$	Thermal Protection	Thermal Protection Temperature	--	150	--	$^{\circ}C$
		Protection Hysterisys	--	20	--	
PSRR	Ripple Rejection	$f = 10kHz, I_{OUT} = 50mA, C_{bypass} = 0.1\mu F$	--	70	--	dB
$I_Q$	Quiescent Current	$V_{EN} = 0.4V$	--	0.01	--	$\mu A$
		$V_{EN} = V_{IN}$	--	35	--	
$V_{TH(EN)}$	Enable Input Threshold Voltage	Voltage Raising, Output Turns On, Logic High	1.6	--	--	V
		Voltage Falling, Output Turns Off, Logic Low	--	--	0.4	
$I_{LIMIT}$	Current Limit		--	600	--	mA

**Note 1:** Exceeding the absolute maximum rating may damage the device.

**Note 2:** The device is not guaranteed to function outside its operating rating.

**Note 3:** The maximum allowable power dissipation at any  $T_A$  (ambient temperature) is calculated using:  $P_{D(MAX)} = (T_{J(MAX)} - T_A)/\theta_{JA}$ . Exceeding the maximum allowable power dissipation will result in excessive die temperature, and the regulator will go into thermal shutdown. See "Thermal Consideration" section for details

**Note 4:** Output voltage temperature coefficient is the worst case voltage change divided by the total temperature range.

**Note 5:** Regulation is measured at constant junction temperature using low duty cycle pulse testing. Parts are tested for load regulation in the load range from 0.1mA to 300mA. Changes in output voltage due to heating effects are covered by the thermal regulation specification.

**Note 6:** Dropout voltage is defined as the input to output differential at which the output voltage drops 100mV below its nominal value measured at 0.8V differential.

**Note 7:** The  $C_{in}$  or  $C_{out}$  should be chosen carefully. Please refer to the Application Hints

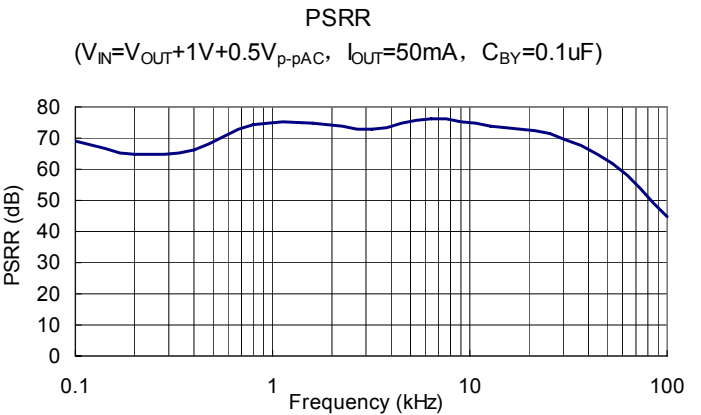
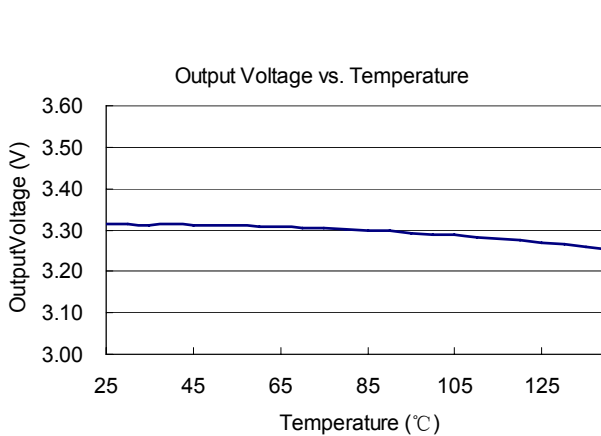
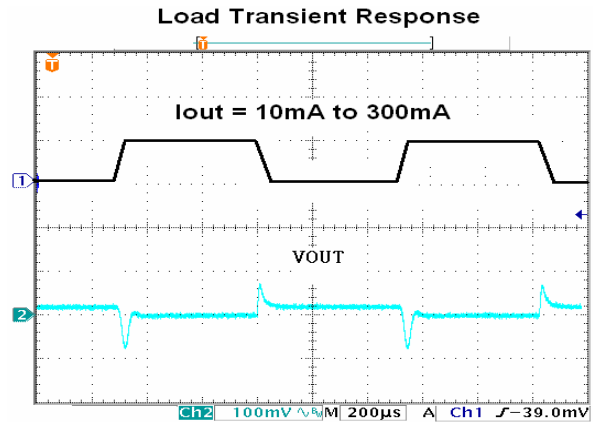
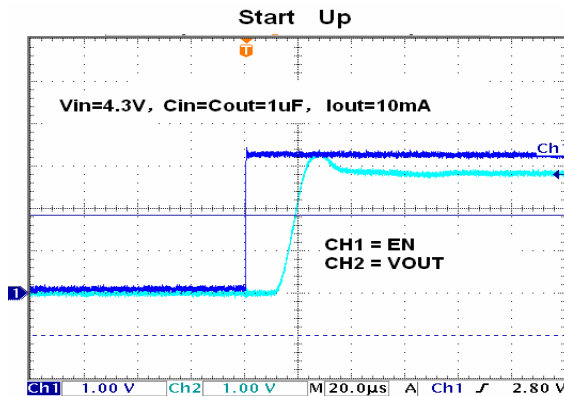
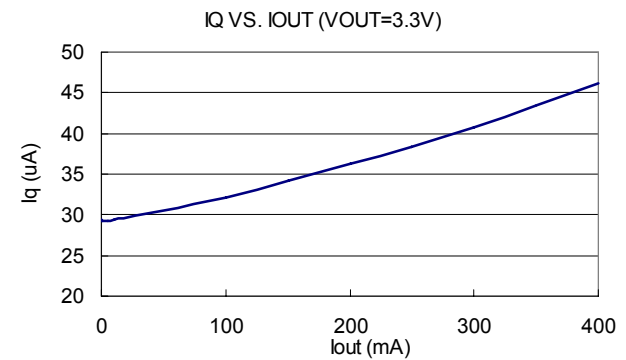
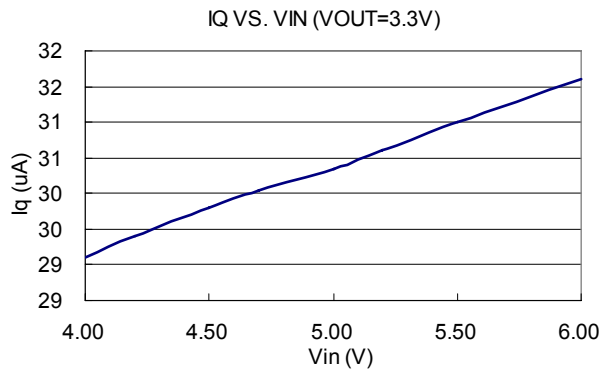
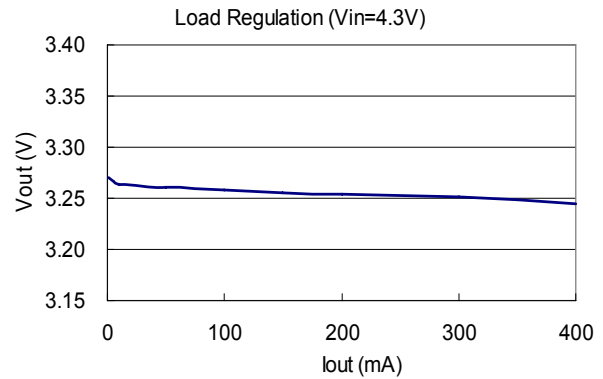
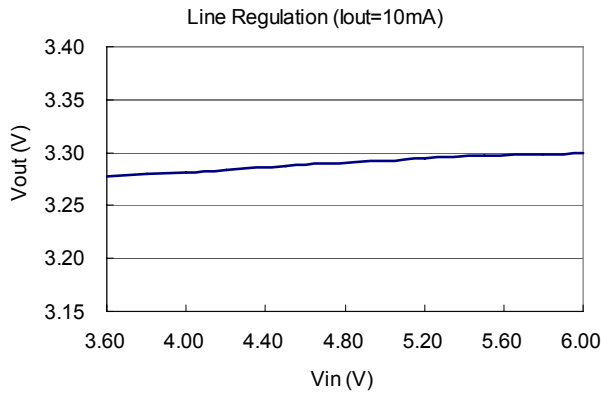



### Application Hints

Like any low dropout regulator, SE5509B requires external capacitors to ensure stability. The external capacitors must be carefully selected to ensure performance.

### Input Capacitor

An input capacitor of at least 1 $\mu$ F is required. The inexpensive Electrolytic capacitor is preferred. The value can be increased without upper limit.

### Output Capacitor

An output capacitor is required for stability. It must be placed no more than 1 cm away from the V<sub>OUT</sub> pin, and connected directly between V<sub>OUT</sub> and GND pins. The inexpensive Electrolytic capacitor is recommended. The minimum value is 1 $\mu$ F but may be increased without limit.

### Thermal Considerations

It is important that the thermal limit of the package is not exceeded. The SE5509B has built-in thermal protection. When the thermal limit is exceeded, the IC will enter protection, and V<sub>OUT</sub> will be pulled to ground. The power dissipation for a given application can be calculated as following:

The power dissipation (P<sub>D</sub>) is

$$P_D = I_{OUT} * [V_{IN} - V_{OUT}]$$

The thermal limit of the package is then limited to  $P_{D(MAX)} = [T_J - T_A]/\Theta_{JA}$  where T<sub>J</sub> is the junction temperature, T<sub>A</sub> is the ambient temperature, and  $\Theta_{JA}$  is around 230°C/W for SE5509B. SE5509B is designed to enter thermal protection at 150°C. For example, if T<sub>A</sub> is 25°C then the maximum P<sub>D</sub> is limited to about 0.6W. In other words, if I<sub>OUT(MAX)</sub> = 300mA, then [V<sub>IN</sub> - V<sub>OUT</sub>] cannot exceed 2V.

### Application Diagram

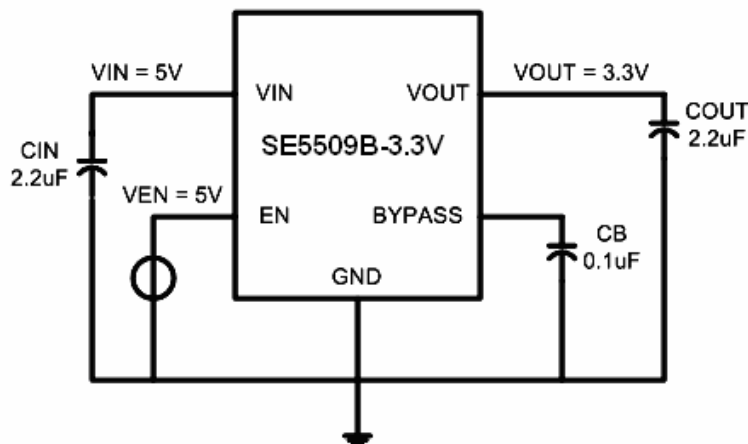



**OUTLINE DRAWING SOT-23-5L**

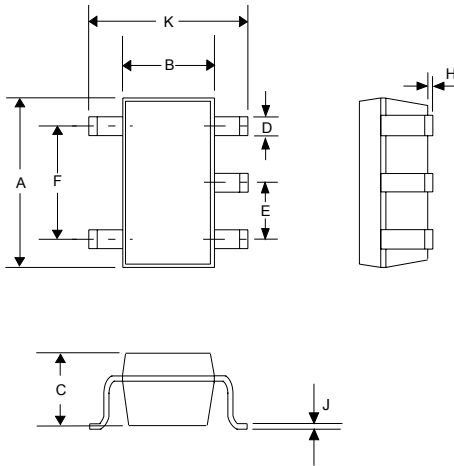

DIMENSIONS				
DIM <sup>N</sup>	INCHES		MM	
	MIN	MAX	MIN	MAX
A	0.110	0.120	2.80	3.05
B	0.059	0.070	1.50	1.75
C	0.036	0.051	0.90	1.30
D	0.014	0.020	0.35	0.50
E	-	0.037	-	0.95
F	-	0.075	-	1.90
H	-	0.006	-	0.15
J	0.0035	0.008	0.090	0.20
K	0.102	0.118	2.60	3.00

**OUTLINE DRAWING TSOP-5**

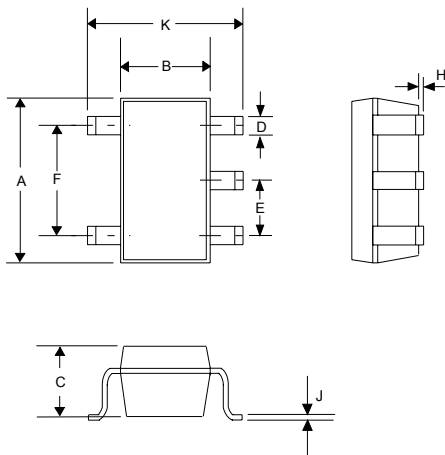

DIMENSIONS				
DIM <sup>N</sup>	INCHES		MM	
	MIN	MAX	MIN	MAX
A	0.110	0.120	2.80	3.05
B	0.059	0.070	1.50	1.75
C	0.036	0.040	0.90	1.00
D	0.014	0.020	0.35	0.50
E	-	0.037	-	0.95
F	-	0.075	-	1.90
H	-	0.006	-	0.15
J	0.0035	0.008	0.090	0.20
K	0.102	0.118	2.60	3.00



## **Contact Information**

### Seaward Electronics Incorporated – China

Room 1605, Building 1, International Pioneering Park, #1 Shangdi Xinxu Rd.

Haidian District, Beijing 100085, China

Tel: 86-10-8289-5700/01/05

Fax: 86-10-8289-5706

Email: [sales@seawardinc.com.cn](mailto:sales@seawardinc.com.cn)

### Seaward Electronics Corporation – Taiwan

2F, #181, Sec. 3, Min Quan East Rd.

Taipei, Taiwan R.O.C

Tel: 886-2-2712-0307

Fax: 886-2-2712-0191

Email: [sales@seawardinc.com.tw](mailto:sales@seawardinc.com.tw)

### Seaward Electronics Incorporated – North America

1512 Centre Pointe Dr.

Milpitas, CA95035, USA

Tel: 1-408-821-6600

Last Updated - 4/30/2008

---

Revision 4/30/2008

**Preliminary and all contents are subject to change without prior notice**

© Seaward Electronics Inc., 2006. • [www.seawardinc.com](http://www.seawardinc.com) • Page 7