

## LOW POWER DUAL CMOS TIMER

- VERY LOW POWER CONSUMPTION :  
220  $\mu$ A typ at  $V_{CC} = 5V$   
180  $\mu$ A typ at  $V_{CC} = 3V$
- HIGH MAXIMUM ASTABLE FREQUENCY  
2.7MHz
- PIN-TO-PIN AND FUNCTIONALLY  
COMPATIBLE WITH BIPOLAR NE556
- WIDE VOLTAGE RANGE : +2V to +16V
- HIGH OUTPUT CURRENT CAPABILITY
- SUPPLY CURRENT SPIKES REDUCED  
DURING OUTPUT TRANSITIONS
- HIGH INPUT IMPEDANCE :  $10^{12}\Omega$
- OUTPUT COMPATIBLE WITH TTL, CMOS  
AND LOGIC MOS

### DESCRIPTION

The TS556 is a dual CMOS timer which offers very low consumption ( $I_{cc(TYP)} TS556 = 220\mu A$  at  $V_{CC}=+5V$  versus  $I_{cc(TYP)} NE556 = 6mA$ ) and high frequency  $f_{(max.)} TS556 = 2.7MHz$  versus  $f_{(max.)} NE556 = 0.1 MHz$ )

Thus, either in Monostable or Astable mode, timing remains very accurate.

The TS556 provides reduced supply current spikes during output transitions, which enables the use of lower decoupling capacitors compared to those required by bipolar NE556.

Timing capacitors can also be minimized due to high input impedance ( $10^{12}\Omega$ ).

### ORDER CODES

Part Number	Temperature Range	Package	
		N	D
TS556C	0°C, +70°C	•	•
TS556I	-40°C, +125°C	•	•
TS556M	-55°C, +125°C	•	•

N = Dual in Line Package (DIP)  
D = Small Outline Package (SO) - also available in Tape & Reel (DT)

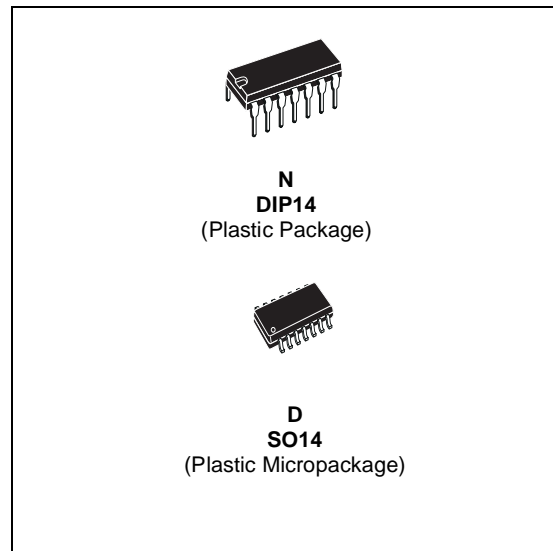

### PIN CONNECTIONS (top view)

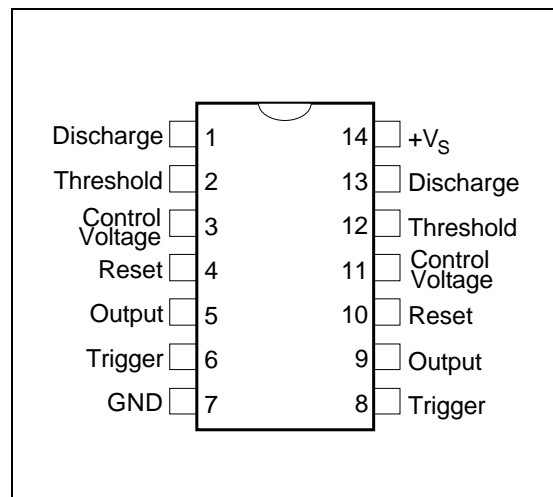

**BLOCK DIAGRAM**

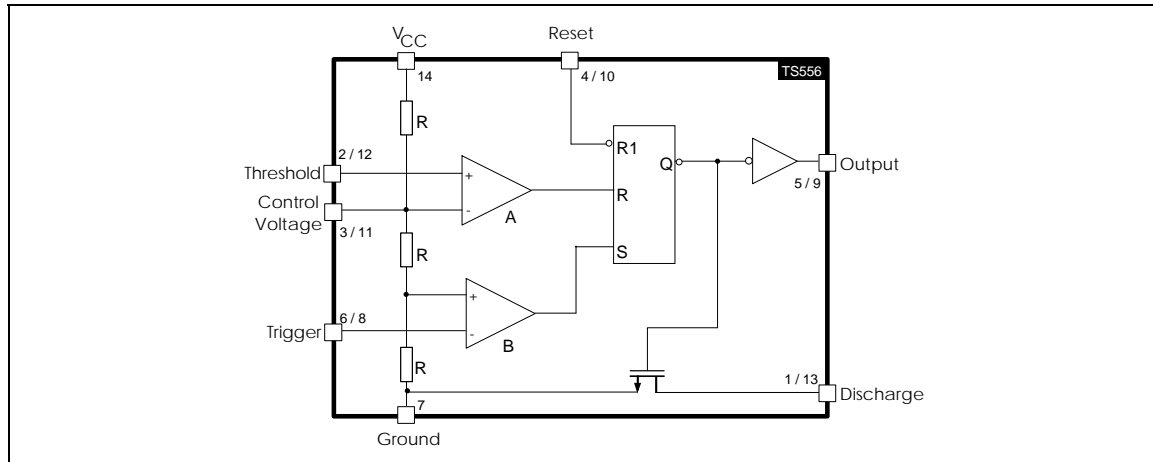

**FUNCTION TABLE**

RESET	TRIGGER	THRESHOLD	OUTPUT
Low	x	x	Low
High	Low	x	High
High	High	High	Low
High	High	Low	Previous State

**LOW** <-----> Level Voltage  $\leq$  Min voltage specified  
**HIGH** <-----> Level Voltage  $\geq$  Max voltage specified  
**x** <-----> Irrelevant

**ABSOLUTE MAXIMUM RATINGS**

Symbol	Parameter	Value	Unit
$V_{CC}$	Supply Voltage	+18	V
$T_j$	Junction Temperature	+150	$^{\circ}C$
$T_{stg}$	Storage Temperature Range	-65 to +150	$^{\circ}C$
$P_D$	Power dissipation <sup>1)</sup>	DIP14: 1560 SO14: 830	mW

1.  $T_j = 150^{\circ}C$ ,  $T_{amb} = 25^{\circ}C$  with  $R_{thja} = 80^{\circ}C/W$  for DIP14 package  
 $R_{thja} = 150^{\circ}C/W$  for SO14 package

**OPERATING CONDITIONS**

Symbol	Parameter	Value	Unit
$V_{CC}$	Supply Voltage	+2 to +16	V
$T_{oper}$	Operating Free Air Temperature Range	TS556C: 0 to +70 TS556I: -40 to +125 TS556M: -55 to +125	$^{\circ}C$

SCHEMATIC DIAGRAM (1/2 TS556)

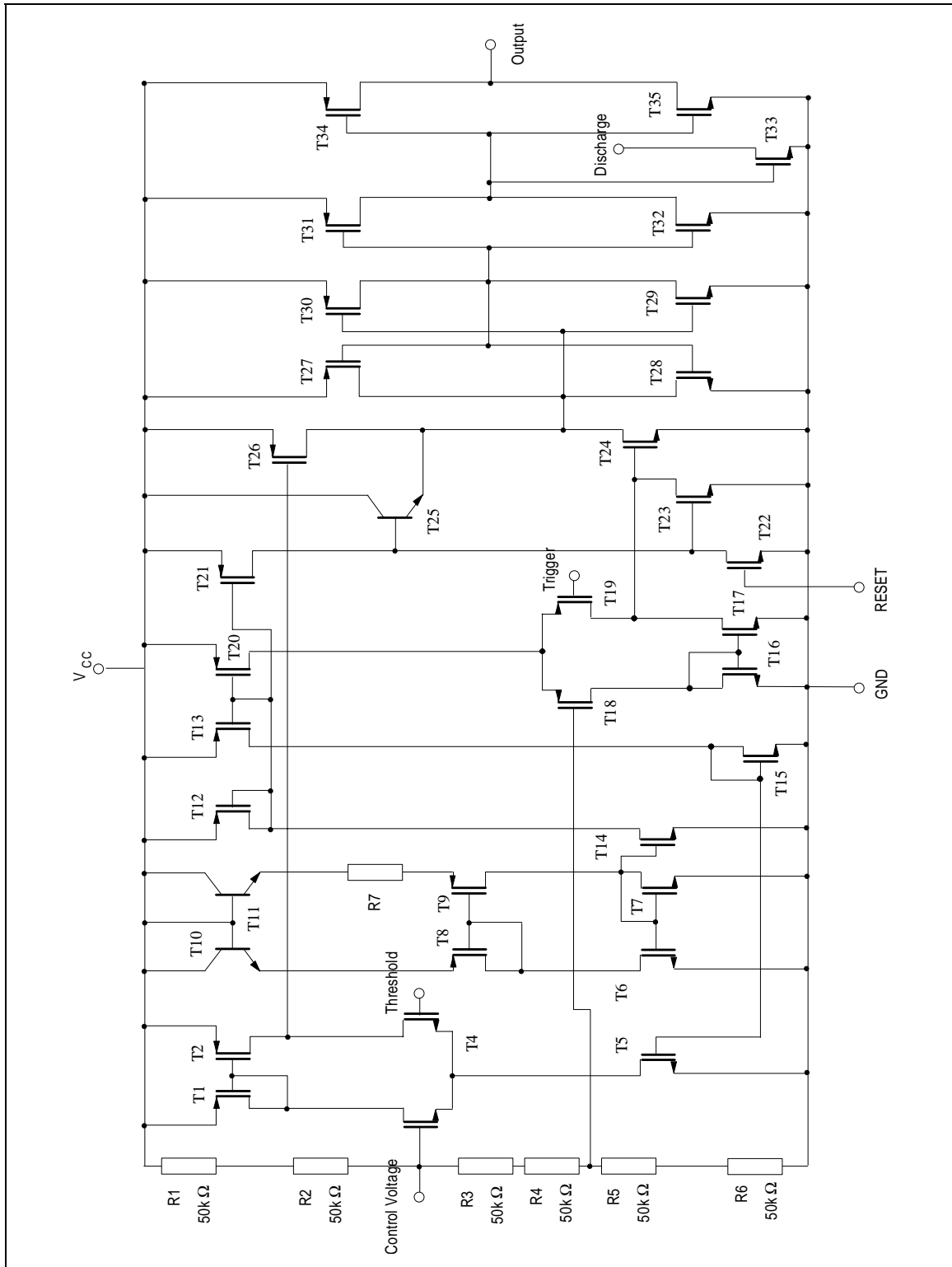

**STATIC ELECTRICAL CHARACTERISTICS** $V_{CC} = +2V$ ,  $T_{amb} = +25^{\circ}C$ , Reset to  $V_{CC}$  (unless otherwise specified)

Symbol	Parameter	Min.	Typ.	Max.	Unit
$I_{CC}$	Supply Current (no load, High and Low States) $T_{min.} \leq T_{amb} \leq T_{max.}$		130	400 400	$\mu A$
$V_{CL}$	Control Voltage Level $T_{min.} \leq T_{amb} \leq T_{max.}$	1.2 1.1	1.3	1.4 1.5	V
$V_{DIS}$	Discharge Saturation Voltage ( $I_{dis} = 1mA$ ) $T_{min.} \leq T_{amb} \leq T_{max.}$		0.05	0.2 0.25	V
$I_{DIS}$	Discharge Pin Leakage Current		1	100	nA
$V_{OL}$	Low Level Output Voltage ( $I_{sink} = 1mA$ ) $T_{min.} \leq T_{amb} \leq T_{max.}$		0.1	0.3 0.35	V
$V_{OH}$	High Level Output Voltage ( $I_{source} = -0.3mA$ ) $T_{min.} \leq T_{amb} \leq T_{max.}$	1.5 1.5	1.9		V
$V_{TRIG}$	Trigger Voltage $T_{min.} \leq T_{amb} \leq T_{max.}$	0.4 0.3	0.67	0.95 1.05	V
$I_{TRIG}$	Trigger Current		10		pA
$I_{TH}$	Threshold Current		10		pA
$V_{RESET}$	Reset Voltage $T_{min.} \leq T_{amb} \leq T_{max.}$	0.4 0.3	1.1	1.5 2.0	V
$I_{RESET}$	Reset Current		10		pA

**ELECTRICAL CHARACTERISTICS** $V_{CC} = +3V$ ,  $T_{amb} = +25^{\circ}C$ , Reset to  $V_{CC}$  (unless otherwise specified)

Symbol	Parameter	Min.	Typ.	Max.	Unit
$I_{CC}$	Supply Current (no load, High and Low States) $T_{min.} \leq T_{amb} \leq T_{max.}$		180	460 460	$\mu A$
$V_{CL}$	Control Voltage Level $T_{min.} \leq T_{amb} \leq T_{max.}$	1.8 1.7	2	2.2 2.3	V
$V_{DIS}$	Discharge Saturation Voltage ( $I_{dis} = 1mA$ ) $T_{min.} \leq T_{amb} \leq T_{max.}$		0.05	0.2 0.25	V
$I_{DIS}$	Discharge Pin Leakage Current		1	100	nA
$V_{OL}$	Low Level Output Voltage ( $I_{sink} = 1mA$ ) $T_{min.} \leq T_{amb} \leq T_{max.}$		0.1	0.3 0.35	V
$V_{OH}$	High Level Output Voltage ( $I_{source} = -0.3mA$ ) $T_{min.} \leq T_{amb} \leq T_{max.}$	2.5 2.5	2.9		V
$V_{TRIG}$	Trigger Voltage $T_{min.} \leq T_{amb} \leq T_{max.}$	0.9 0.8	1	1.1 1.2	V
$I_{TRIG}$	Trigger Current		10		pA
$I_{TH}$	Threshold Current		10		pA
$V_{RESET}$	Reset Voltage $T_{min.} \leq T_{amb} \leq T_{max.}$	0.4 0.3	1.1	1.5 2.0	V
$I_{RESET}$	Reset Current		10		pA

**DYNAMIC ELECTRICAL CHARACTERISTICS** $V_{CC} = +3V$ ,  $T_{amb} = +25^{\circ}C$ , Reset to  $V_{CC}$  (unless otherwise specified)

Symbol	Parameter	Min.	Typ.	Max.	Unit
	Timing Accuracy (Monostable) <sup>1)</sup> $R = 10k\Omega$ , $C = 0.1\mu F$ $V_{CC}=+2V$ $V_{CC}=+3V$		1 1		%
	Timing Shift with Supply Voltage Variations (Monostable) <sup>1)</sup> $R = 10k\Omega$ , $C = 0.1\mu F$ , $V_{CC} = +3V \pm 0.3V$		0.5		%/V
	Timing Shift with Temperature <sup>1)</sup> $T_{min.} \leq T_{amb} \leq T_{max}$		75		ppm/ $^{\circ}C$
$f_{max}$	Maximum Astable Frequency <sup>2)</sup> $R_A = 470\Omega$ , $R_B = 200\Omega$ , $C = 200pF$		2		MHz
	Astable Frequency Accuracy <sup>2)</sup> $R_A = R_B = 1k\Omega$ to $100k\Omega$ , $C = 0.1\mu F$		5		%
	Timing Shift with Supply Voltage Variations (Astable mode) <sup>2)</sup> $R_A = R_B = 10k\Omega$ , $C = 0.1\mu F$ , $V_{CC} = +3$ to $+5V$		0.5		%/V
$t_R$	Output Rise Time ( $C_{load} = 10pF$ )		25		ns
$t_F$	Output Fall Time ( $C_{load} = 10pF$ )		20	-	ns
$t_{PD}$	Trigger Propagation Delay		100		ns
$t_{RPW}$	Minimum Reset Pulse Width ( $V_{trig} = +3V$ )		350		ns

1. see figure 2

2. see figure 4

**STATIC ELECTRICAL CHARACTERISTICS**

$V_{CC} = +5V$ ,  $T_{amb} = +25^{\circ}C$ , Reset to  $V_{CC}$  (unless otherwise specified)

Symbol	Parameter	Min.	Typ.	Max.	Unit
$I_{CC}$	Supply Current (no load, High and Low States) $T_{min.} \leq T_{amb} \leq T_{max.}$		220	500 500	$\mu A$
$V_{CL}$	Control Voltage Level $T_{min.} \leq T_{amb} \leq T_{max.}$	2.9 2.8	3.3	3.8 3.9	V
$V_{DIS}$	Discharge Saturation Voltage ( $I_{dis} = 10mA$ ) $T_{min.} \leq T_{amb} \leq T_{max.}$		0.2	0.3 0.35	V
$I_{DIS}$	Discharge Pin Leakage Current		1	100	nA
$V_{OL}$	Low Level Output Voltage ( $I_{sink} = 8mA$ ) $T_{min.} \leq T_{amb} \leq T_{max.}$		0.3	0.6 0.8	V
$V_{OH}$	High Level Output Voltage ( $I_{source} = -2mA$ ) $T_{min.} \leq T_{amb} \leq T_{max.}$	4.4 4.4	4.6		V
$V_{TRIG}$	Trigger Voltage $T_{min.} \leq T_{amb} \leq T_{max.}$	1.36 1.26	1.67	1.96 2.06	V
$I_{TRIG}$	Trigger Current		10		$\mu A$
$I_{TH}$	Threshold Current		10		$\mu A$
$V_{RESET}$	Reset Voltage $T_{min.} \leq T_{amb} \leq T_{max.}$	0.4 0.3	1.1	1.5 2.0	V
$I_{RESET}$	Reset Current		10		$\mu A$

**DYNAMIC ELECTRICAL CHARACTERISTICS**

$V_{CC} = +5V$ ,  $T_{amb} = +25^{\circ}C$ , Reset to  $V_{CC}$  (unless otherwise specified)

Symbol	Parameter	Min.	Typ.	Max.	Unit
	Timing Accuracy (Monostable) <sup>1)</sup> $R = 10k\Omega$ , $C = 0.1\mu F$		2		%
	Timing Shift with Supply Voltage Variations (Monostable) <sup>1)</sup> $R = 10k\Omega$ , $C = 0.1\mu F$ , $V_{CC} = +5V \pm 1V$		0.38		%/V
	Timing Shift with Temperature <sup>1)</sup> $T_{min.} \leq T_{amb} \leq T_{max.}$		75		ppm/ $^{\circ}C$
$f_{max}$	Maximum Astable Frequency <sup>2)</sup> $R_A = 470\Omega$ , $R_B = 200\Omega$ , $C = 200pF$		2.7		MHz
	Astable Frequency Accuracy <sup>2)</sup> $R_A = R_B = 1k\Omega$ to $100k\Omega$ , $C = 0.1\mu F$		3		%
	Timing Shift with Supply Voltage Variations (Astable mode) <sup>2)</sup> $R_A = R_B = 1k\Omega$ to $100k\Omega$ , $C = 0.1\mu F$ , $V_{CC} = +5$ to $+12V$		0.1		%/V
$t_R$	Output Rise Time ( $C_{load} = 10pF$ )		25		ns
$t_F$	Output Fall Time ( $C_{load} = 10pF$ )		20	-	ns
$t_{PD}$	Trigger Propagation Delay		100		ns
$t_{RPW}$	Minimum Reset Pulse Width ( $V_{trig} = +5V$ )		350		ns

1. see figure 2
2. see figure 4

**STATIC ELECTRICAL CHARACTERISTICS**

$V_{CC} = +12V$ ,  $T_{amb} = +25^{\circ}C$ , Reset to  $V_{CC}$  (unless otherwise specified)

Symbol	Parameter	Min.	Typ.	Max.	Unit
$I_{CC}$	Supply Current (no load, High and Low States) $T_{min.} \leq T_{amb} \leq T_{max.}$		340	800 800	$\mu A$
$V_{CL}$	Control Voltage Level $T_{min.} \leq T_{amb} \leq T_{max.}$	7.4 7.3	8	8.6 8.7	V
$V_{DIS}$	Discharge Saturation Voltage ( $I_{dis} = 80mA$ ) $T_{min.} \leq T_{amb} \leq T_{max.}$		0.09	1.6 2.0	V
$I_{DIS}$	Discharge Pin Leakage Current		1	100	nA
$V_{OL}$	Low Level Output Voltage ( $I_{sink} = 50mA$ ) $T_{min.} \leq T_{amb} \leq T_{max.}$		1.2	2 2.8	V
$V_{OH}$	High Level Output Voltage ( $I_{source} = -10mA$ ) $T_{min.} \leq T_{amb} \leq T_{max.}$	10.5 10.5	11		V
$V_{TRIG}$	Trigger Voltage $T_{min.} \leq T_{amb} \leq T_{max.}$	3.2 3.1	4	4.8 4.9	V
$I_{TRIG}$	Trigger Current		10		$\mu A$
$I_{TH}$	Threshold Current		10		$\mu A$
$V_{RESET}$	Reset Voltage $T_{min.} \leq T_{amb} \leq T_{max.}$	0.4 0.3	1.1	1.5 2.0	V
$I_{RESET}$	Reset Current		10		$\mu A$

**DYNAMIC ELECTRICAL CHARACTERISTICS**

$V_{CC} = +12V$ ,  $T_{amb} = +25^{\circ}C$ , Reset to  $V_{CC}$  (unless otherwise specified)

Symbol	Parameter	Min.	Typ.	Max.	Unit
	Timing Accuracy (Monostable) <sup>1)</sup> $R = 10k\Omega$ , $C = 0.1\mu F$		4		%
	Timing Shift with Supply Voltage Variations (Monostable) $R = 10k\Omega$ , $C = 0.1\mu F$ , $V_{CC} = +5V \pm 1V$		0.38		%/V
	Timing Shift with Temperature $T_{min.} \leq T_{amb} \leq T_{max.}$ , $V_{CC} = +5V$		75		ppm/ $^{\circ}C$
$f_{max}$	Maximum Astable Frequency $R_A = 470\Omega$ , $R_B = 200\Omega$ , $C = 200pF$ , $V_{CC} = +5V$		2.7		MHz
	Astable Frequency Accuracy <sup>2)</sup> $R_A = R_B = 1k\Omega$ to $100k\Omega$ , $C = 0.1\mu F$		3		%
	Timing Shift with Supply Voltage Variations (Astable mode) $R_A = R_B = 1k\Omega$ to $100k\Omega$ , $C = 0.1\mu F$ , $V_{CC} = 5$ to $+12V$		0.1		%/V

1. see figure 2

2. see figure 4

**TYPICAL CHARACTERISTICS**

**Figure 1 :** Supply Current (each timer) versus Supply Voltage

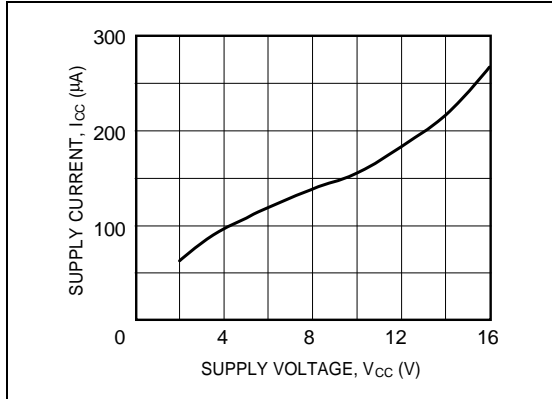

**APPLICATION INFORMATION**

**MONOSTABLE OPERATION**

In the monostable mode, the timer operates like a one-shot generator. Referring to figure 2, the external capacitor is initially held discharged by a transistor inside the timer.

**Figure 2 :**

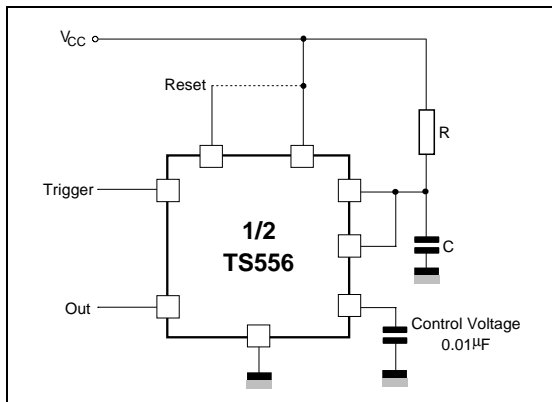

The circuit triggers on a negative-going input signal when the level reaches  $1/3 V_{CC}$ . Once triggered, the circuit remains in this state until the set time has elapsed, even if it is triggered again during this interval. The duration of the output HIGH state is given by  $t = 1.1 R \times C$ .

It can be noticed that since the charge rate and the threshold level of the comparator are both directly proportional to the supply voltage, the timing interval is independent of the supply. Applying a negative pulse simultaneously to the Reset terminal (pin 4) and the Trigger terminal (pin 2) during the timing cycle discharges the external capacitor and causes the cycle to start over. The timing cycle now starts on the positive edge of the reset pulse. While the reset pulse is applied, the output is driven to the LOW state.

When a negative trigger pulse is applied to pin 2, the flip-flop is set, releasing the short circuit across the external capacitor and driving the output HIGH. The voltage across the capacitor increases exponentially with the time constant  $\tau = R \times C$ .

When the voltage across the capacitor equals  $2/3 V_{CC}$ , the comparator resets the flip-flop which then discharges the capacitor rapidly and drives the output to its LOW state.

Figure 3 shows the actual waveforms generated in this mode of operation.

When Reset is not used, it should be tied high to avoid any possible or false triggering.

**Figure 3 :**

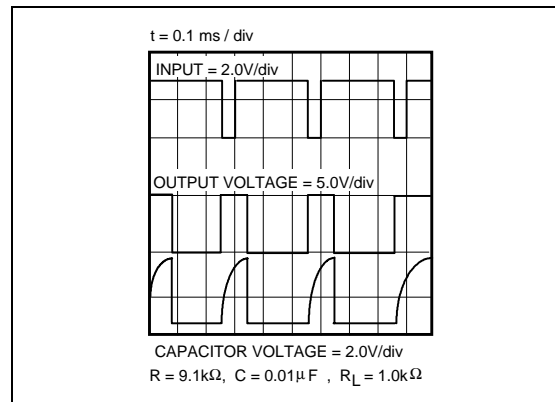



### ASTABLE OPERATION

When the circuit is connected as shown in figure 4 (pin 2 and 6 connected) it triggers itself and free runs as a multivibrator. The external capacitor charges through  $R_A$  and  $R_B$  and discharges through  $R_B$  only. Thus the duty cycle may be precisely set by the ratio of these two resistors.

In the astable mode of operation, C charges and discharges between  $1/3 V_{CC}$  and  $2/3 V_{CC}$ . As in the triggered mode, the charge and discharge times and therefore frequency, are independent of the supply voltage.

Figure 4:

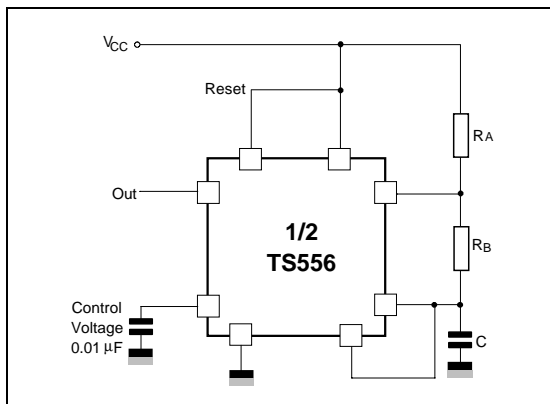

Figure 5 shows actual waveforms generated in this mode of operation.

The charge time (output HIGH) is given by :

$$t_1 = 0.693 (R_A + R_B) C$$

and the discharge time (output LOW) by :

$$t_2 = 0.693 \times R_B \times C$$

Thus the total period T is given by :

$$T = t_1 + t_2 = 0.693 (R_A + 2R_B) C$$

The frequency of oscillation is then :

$$f = \frac{1}{T} = \frac{1.44}{(R_A + 2R_B)C}$$

The duty cycle is given by :

$$D = \frac{R_B}{R_A + 2R_B}$$

Figure 5:

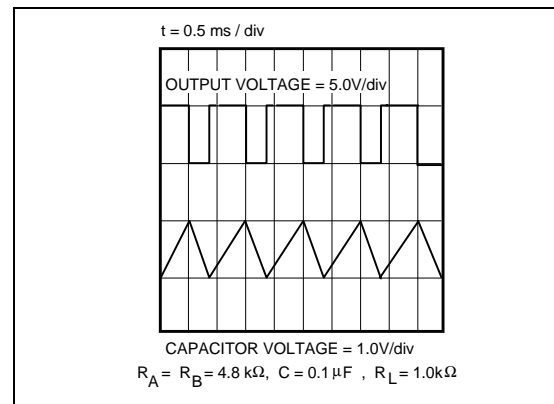

**PACKAGE MECHANICAL DATA**

14 PINS - PLASTIC DIP

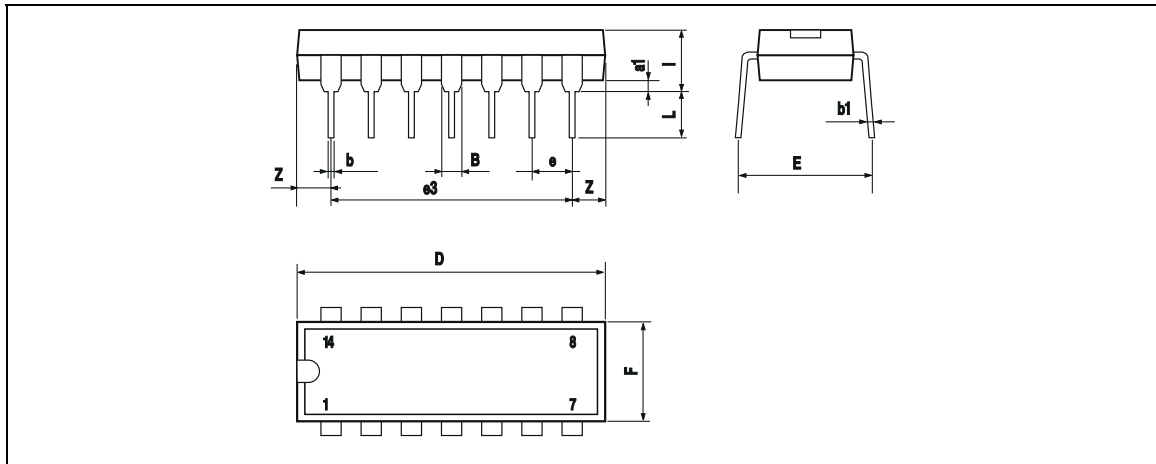

Dimensions	Millimeters			Inches		
	Min.	Typ.	Max.	Min.	Typ.	Max.
a1	0.51			0.020		
B	1.39		1.65	0.055		0.065
b		0.5			0.020	
b1		0.25			0.010	
D			20			0.787
E		8.5			0.335	
e		2.54			0.100	
e3		15.24			0.600	
F			7.1			0.280
i			5.1			0.201
L		3.3			0.130	
Z	1.27		2.54	0.050		0.100

**PACKAGE MECHANICAL DATA**  
14 PINS - PLASTIC MICROPACKAGE (SO)

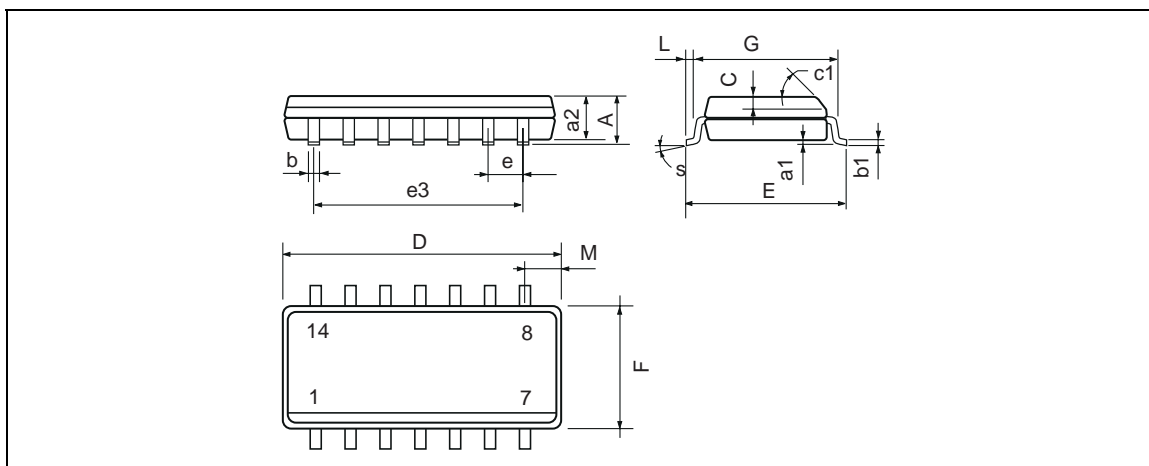

Dimensions	Millimeters			Inches		
	Min.	Typ.	Max.	Min.	Typ.	Max.
A			1.75			0.069
a1	0.1		0.2	0.004		0.008
a2			1.6			0.063
b	0.35		0.46	0.014		0.018
b1	0.19		0.25	0.007		0.010
C		0.5			0.020	
c1	45° (typ.)					
D (1)	8.55		8.75	0.336		0.344
E	5.8		6.2	0.228		0.244
e		1.27			0.050	
e3		7.62			0.300	
F (1)	3.8		4.0	0.150		0.157
G	4.6		5.3	0.181		0.208
L	0.5		1.27	0.020		0.050
M			0.68			0.027
S	8° (max.)					

Note : (1) D and F do not include mold flash or protrusions - Mold flash or protrusions shall not exceed 0.15mm (.066 inc) ONLY FOR DATA BOOK.

Information furnished is believed to be accurate and reliable. However, STMicroelectronics assumes no responsibility for the consequences of use of such information nor for any infringement of patents or other rights of third parties which may result from its use. No license is granted by implication or otherwise under any patent or patent rights of STMicroelectronics. Specifications mentioned in this publication are subject to change without notice. This publication supersedes and replaces all information previously supplied. STMicroelectronics products are not authorized for use as critical components in life support devices or systems without express written approval of STMicroelectronics.

© The ST logo is a registered trademark of STMicroelectronics

© 2003 STMicroelectronics - Printed in Italy - All Rights Reserved  
STMicroelectronics GROUP OF COMPANIES

Australia - Brazil - China - Finland - France - Germany - Hong Kong - India - Italy - Japan - Malaysia - Malta - Morocco  
Singapore - Spain - Sweden - Switzerland - United Kingdom

© <http://www.st.com>

