

BCD-TO-7 SEGMENT LATCH/DECODER/LCD DRIVER

- DISPLAY BLANKING OF ALL ILLEGAL INPUT COMBINATIONS
- LATCH STORAGE OF CODE
- CAPABILITY OF DRIVING TWO LOW POWER TTL LOADS, TWO HTL LOADS, OR ONE LOW POWER SCHOTTKY LOAD OVER THE FULL RATED-TEMPERATURE RANGE
- PIN-FOR-PIN REPLACEMENT FOR THE HCF4056B (with pin 7 tied to V_{SS})
- DIRECT LED DRIVING CAPABILITY
- 100% TESTED FOR QUIESCENT CURRENT AT 20V
- MAXIMUM INPUT CURRENT OF 1A AT 18V OVER FULL PACKAGE-TEMPERATURE RANGE ; 100nA AT 18V AND 25°C
- NOISE MARGIN (full package-temperature range) = 1V AT $V_{DD} = 5V$
 2V AT $V_{DD} = 10V$
 2.5V AT $V_{DD} = 15V$
- 5-V, 10-V, AND 15-V PARAMETRIC RATINGS

Applications :

- INSTRUMENT DISPLAY DRIVER
- DASHBOARD DISPLAY DRIVER
- COMPUTER/CALCULATOR DISPLAY DRIVER
- TIMING DEVICE DRIVER (clocks, watches, timers)

DESCRIPTION

The HCC/HCF4543B is a BCD-to-seven segment latch/decoder/driver designed primarily for liquid-crystal display (LCD) applications. It is also capable of driving light emitting diode (LED), incandescent, gas-discharge, and fluorescent displays. This device is functionally similar to and serves as direct replacement for the HCF4056B when pin 7 is connected to V_{SS} . It differs from the HCF4056B in that it has a display blanking capability instead of a level-shifting function and requires only one power supply. When the HCF4056B is used in the level shifting mode, two power supplies are required. When the HCF4543B is used for LCD applications, a square wave must be applied to the PHASE input and the backplane of the LCD device. For LED applications a logic 1 is required at the PHASE input for common-cathode devices ; a logic 0 is required for common-anode devices (see truth table).

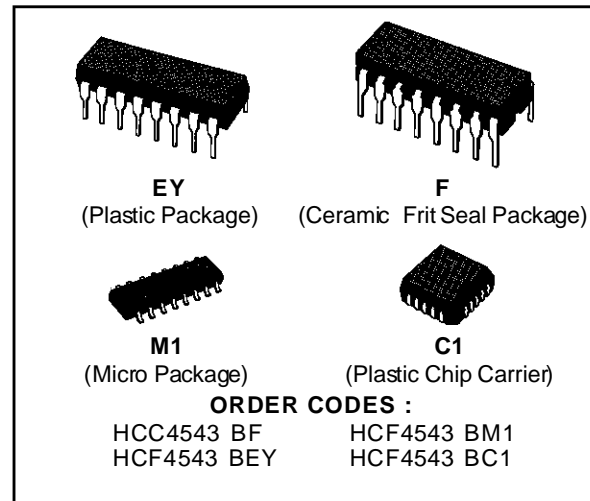

PIN CONNECTION (top view)

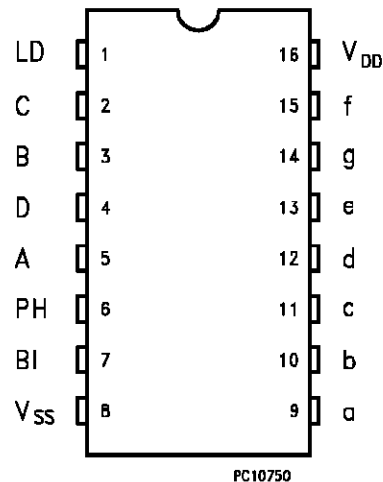

HCC/HCF4543B

ABSOLUTE MAXIMUM RATINGS

Symbol	Parameter	Value	Unit
V_{DD}^*	Supply voltage : HCC Types HCF Types	- 0.5 to + 20 - 0.5 to 18	V V
V_i	Input Voltage	- 0.5 to $V_{DD} + 0.5$	V
I_i	DC Input Current (any one input)	± 10	mA
P_{tot}	Total Power Dissipation (per package) Dissipation per Output Transistor for T_{op} = Full Package-temperature Range	200 100	mW mW
T_{op}	Operating Temperature : HCC Types HCF Types	- 55 to + 125 - 40 to + 85	$^{\circ}C$ $^{\circ}C$
T_{stg}	Storage Temperature	- 65 to + 150	$^{\circ}C$

* All Voltage Values are referred to V_{SS} pin voltage.

LOGIC DIAGRAM (1/2 of device shown)

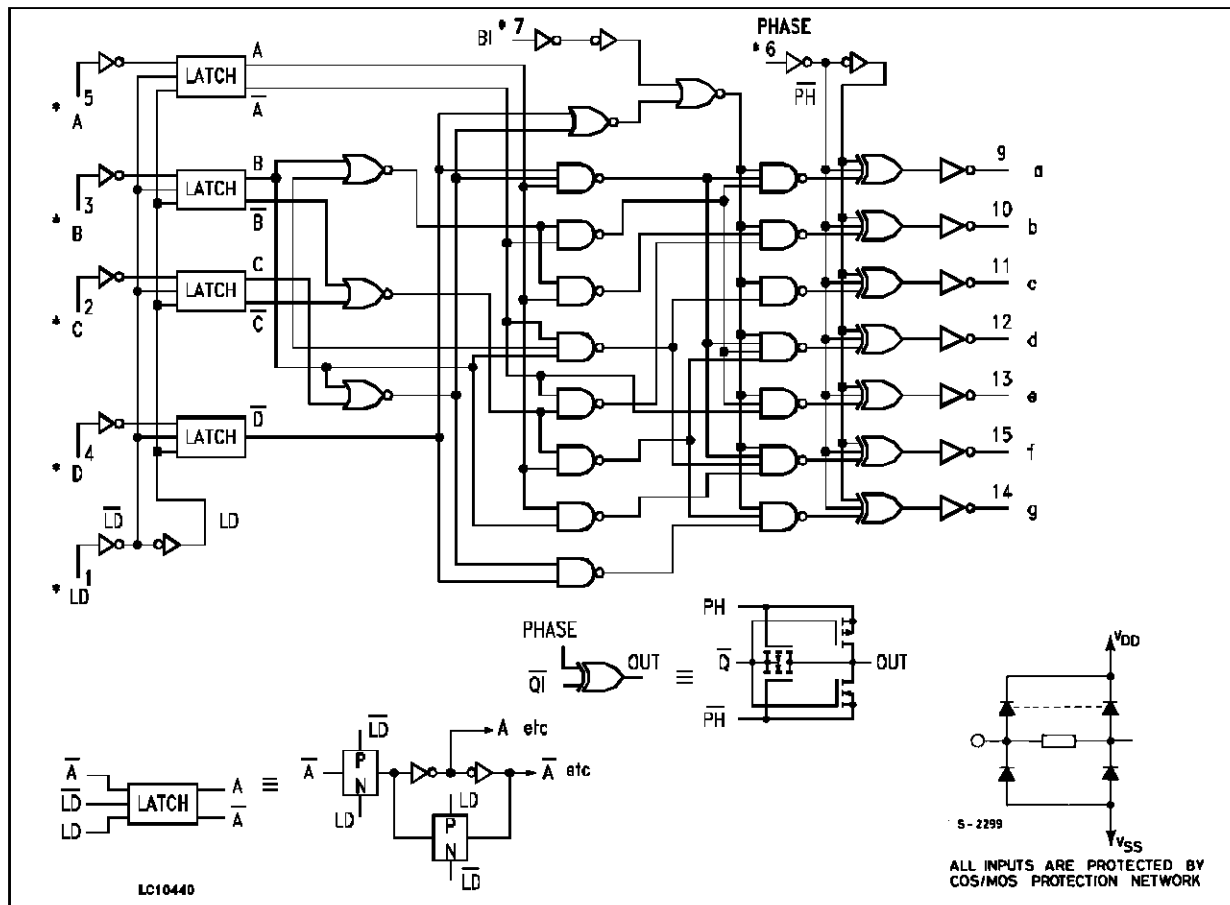

RECOMMENDED OPERATING CONDITIONS

Symbol	Parameter	Value	Unit
V_{DD}	Supply Voltage : HCC Types HCF Types	3 to + 18 3 to + 15	V V
V_i	Input Voltage	0 to V_{DD}	V
T_{op}	Operating Temperature : HCC Types HCF Types	- 55 to + 125 - 40 to + 85	$^{\circ}C$ $^{\circ}C$

TRUTH TABLE

INPUT CODE							OUTPUT STATE							DISPLAY CHARACTER
LD	BI	Ph*	D	C	B	A	a	b	c	d	e	f	g	
X	1	0	X	X	X	X	0	0	0	0	0	0	0	
1	0	0	0	0	0	0	1	1	1	1	1	1	0	0
1	0	0	0	0	0	1	0	1	1	0	0	0	0	1
1	0	0	0	0	1	0	1	1	0	1	1	0	1	0
1	0	0	0	0	1	1	1	1	1	1	0	0	1	1
1	0	0	0	1	0	0	0	1	1	0	0	1	1	1
1	0	0	0	1	0	1	1	0	1	1	0	1	1	1
1	0	0	0	1	1	0	1	0	1	1	1	1	1	1
1	0	0	0	1	1	1	1	1	1	0	0	0	0	0
1	0	0	1	0	0	0	1	1	1	1	1	1	1	1
1	0	0	1	0	0	1	1	1	1	1	0	1	1	1
1	0	0	1	0	1	0	0	0	0	0	0	0	0	Blank
1	0	0	1	0	1	1	0	0	0	0	0	0	0	Blank
1	0	0	1	1	0	0	0	0	0	0	0	0	0	Blank
1	0	0	1	1	1	1	0	0	0	0	0	0	0	Blank
0	0	0	X	X	X	X	**							**
•	•	•	•				Inverse of Output Combinations Above							Display as above

X = Don't care.

• = Above combinations

* = For liquid-crystal readouts, apply a square wave to Ph.

For common cathode LED readouts, select Ph = 0.

For common anode LED readouts, select Ph = 1.

** = Depends upon the BCD code previously applied when LD = 1.

STATIC ELECTRICAL CHARACTERISTICS

Symbol	Parameter		Test Conditions				Value						Unit	
			V _I (V)	V _O (V)	I _O (μ A)	V _{DD} (V)	T _{Low}		25°C			T _{High}		
							Min.	Max.	Min.	Typ.	Max.	Min.		Max.
I _L	Quiescent Current	HCC Types	0/5			5		5		0.04	5		150	μ A
			0/10			10		10		0.04	10		300	
			0/15			15		20		0.04	20		600	
			0/20			20		100		0.08	100		3000	
		HCF Types	0/5			5		5		0.04	5		150	
			0/10			10		10		0.04	10		300	
			0/15			15		20		0.04	20		600	
V _{OH}	Output High Voltage	0/5		< 1	5	4.95		4.95			4.95		V	
		0/10		< 1	10	9.95		9.95			9.95			
		0/15		< 1	15	14.95		14.95			14.95			
V _{OL}	Output Low Voltage	5/0		< 1	5		0.05			0.05		0.05	V	
		10/0		< 1	10		0.05			0.05		0.05		
		15/0		< 1	15		0.05			0.05		0.05		
V _{IH}	Input High Voltage	0.5/4.5	< 1	5	3.5		3.5			3.5			V	
		1/9	< 1	10	7		7			7				
		1.5/13.5	< 1	15	11		11			11				
V _{IL}	Input Low Voltage	4.5/0.5	< 1	5		1.5			1.5		1.5		V	
		9/1	< 1	10		3			3		3			
		13.5/1.5	< 1	15		4			4		4			
I _{OH}	Output Drive Current	HCC Types	0/5	2.5		5	-1.6		-1.3	-2.6		-0.9	mA	
			0/5	4.6		5	-0.46		-0.37	-0.75		-0.26		
			0/10	9.5		10	-0.98		-0.8	-1.6		-0.55		
			0/15	13.5		15	-3.33		-2.7	-5.4		-1.9		
		HCF Types	0/5	2.5		5	1.3		-1.1	-2.6		-0.9		
			0/5	4.6		5	0.36		-0.31	-0.75		-0.25		
			0/10	9.5		10	0.81		-0.68	-1.6		-0.54		
0/15	13.5		15	2.7		-2.3	-5.4		-1.84					
I _{OL}	Output Sink Current	HCC Types	0/5	0.4		5	0.64		0.51	1		0.36	mA	
			0/10	0.5		10	1.6		1.3	2.6		0.9		
			0/15	1.5		15	4.2		3.4	6.8		2.4		
		HCF Types	0/5	0.4		5	0.52		0.44	1		0.36		
			0/10	0.5		10	1.3		1.1	2.6		0.9		
			0/15	1.5		15	3.6		3.0	6.8		2.4		
I _{IH} , I _{IL}	Input Leakage Current	HCC types	0/18	Any Input	18		± 0.1		$\pm 10^{-5}$	± 0.1		± 1	μ A	
		HCF types	0/15		15		± 0.3		$\pm 10^{-5}$	± 0.3		± 1		

* T_{Low} = -55°C for HCC device : -40°C for HCF device.

* T_{High} = +125°C for HCC device : +85°C for HCF device.

The Noise Margin for both "1" and "0" level is : 1V min. with V_{DD} = 5V, 2V min. with V_{DD} = 10V, 2.5V min. with V_{DD} = 15V.

DYNAMIC ELECTRICAL CHARACTERISTICS ($T_{amb} = 25^{\circ}C$, $C_L = 50pF$, $R_L = 200k\Omega$, typical temperature coefficient for all V_{DD} values is $0.3\%/^{\circ}C$, all input rise and fall time = 20ns)

Symbol	Parameter	Test Conditions V_{DD} (V)	Limits All packages			Unit
			Min.	Typ.	Max.	
t_{PHL}	Propagation Delay Time	5		600	1200	ns
		10		200	400	
		15		150	300	
t_{PLH}		5		500	1000	
		10		200	400	
		15		150	300	
t_{rHL}	Transition Time	5		180	360	
		10		90	180	
		15		65	130	
t_{rLH}		5		180	360	
		10		90	180	
		15		65	130	
t_{WH}	Latch Disable Pulse Width	5	250	125		
		10	100	50		
		15	80	40		
t_{SU}	Address Setup Time	5	60	15		
		10	20	- 5		
		15	10	- 5		
t_H	Address Hold Time	5	25	-5		
		10	20	10		
		15	20	0		
C_{IN}	Input Capacitance	Any Input		5	7.5	pF

BCD-to-seven-segment latch/decoder/driver functional diagram

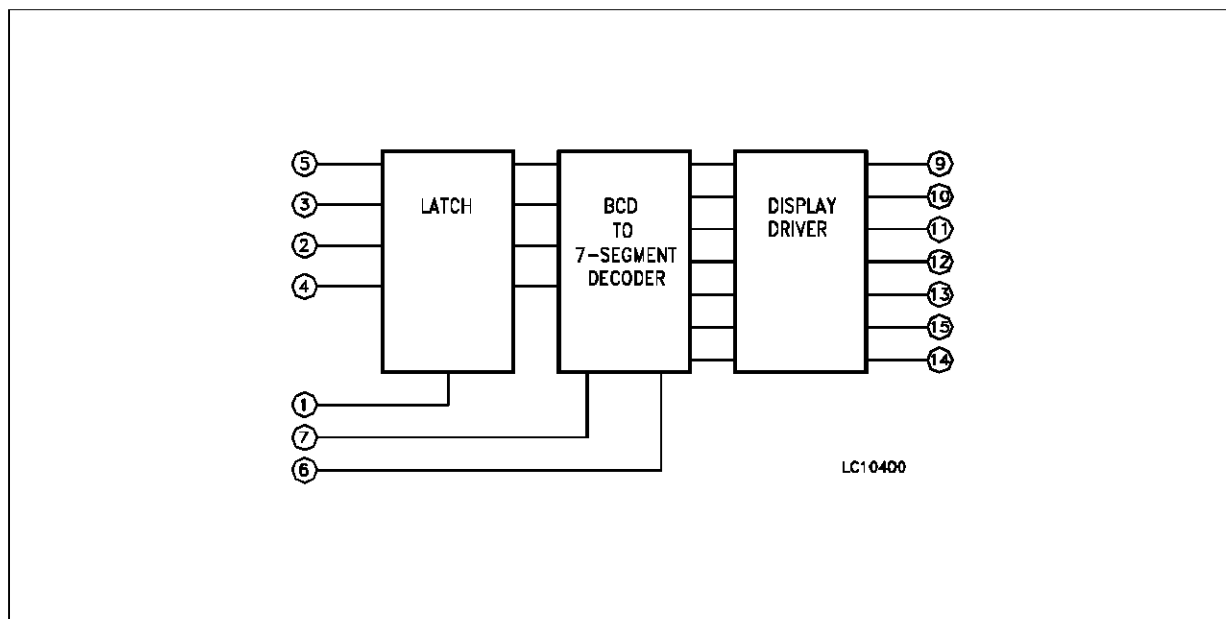

Typical Output Low (sink) Current Characteristics.

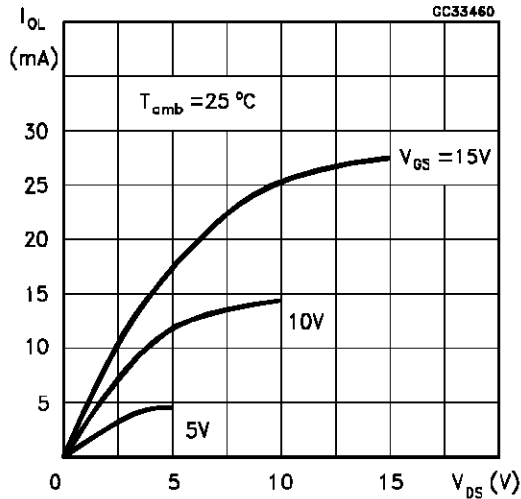

Minimum Output Low (sink) Current Characteristics.

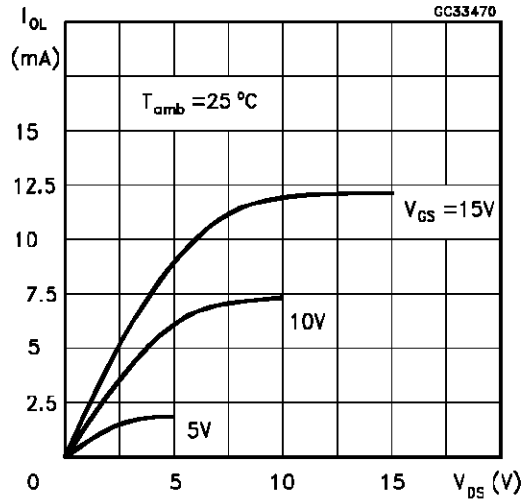

Typical Transition Time as a Function of Load Capacitance

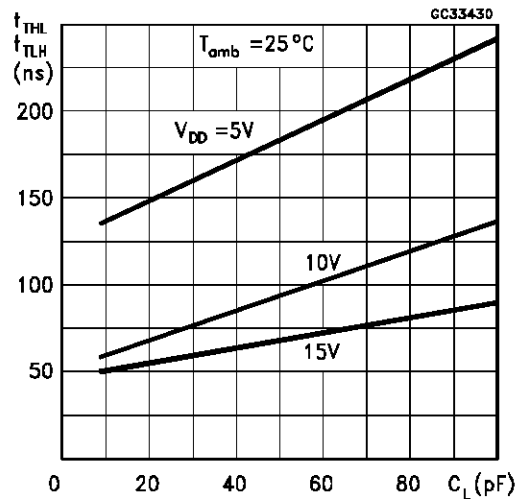

Typical Propagation Delay Time as a Function of Load Capacitance

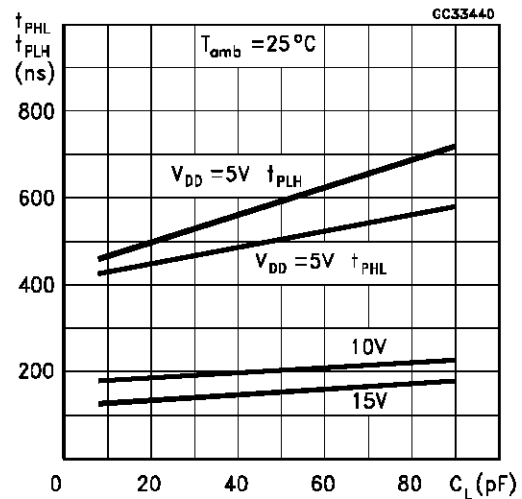

Typical Dynamic Power Dissipation as a Function of Frequency

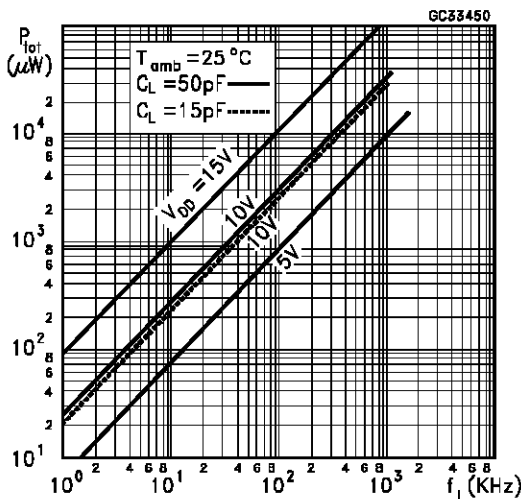

Input Voltage Test Circuit.

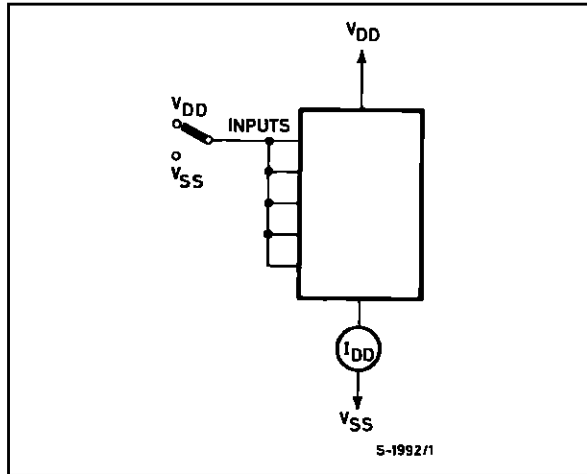

Quiescent Device Current Test Circuit.

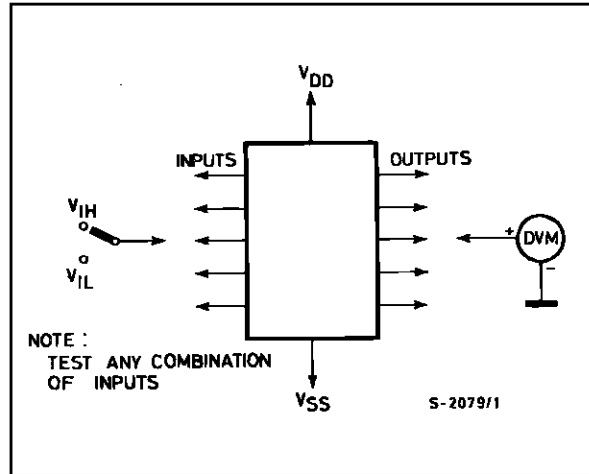

Input-leakage -current Test Circuit.

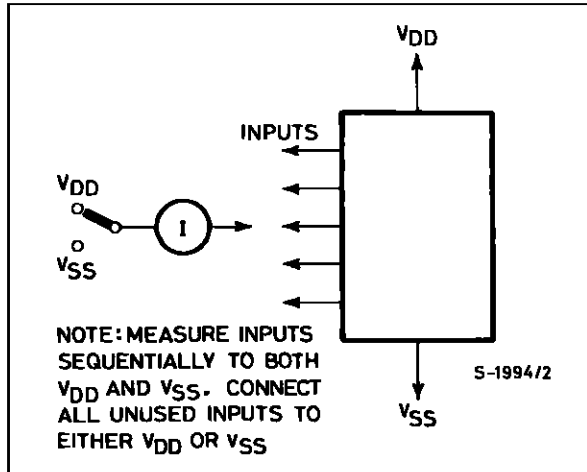

Plastic DIP16 (0.25) MECHANICAL DATA

DIM.	mm			inch		
	MIN.	TYP.	MAX.	MIN.	TYP.	MAX.
a1	0.51			0.020		
B	0.77		1.65	0.030		0.065
b		0.5			0.020	
b1		0.25			0.010	
D			20			0.787
E		8.5			0.335	
e		2.54			0.100	
e3		17.78			0.700	
F			7.1			0.280
I			5.1			0.201
L		3.3			0.130	
Z			1.27			0.050

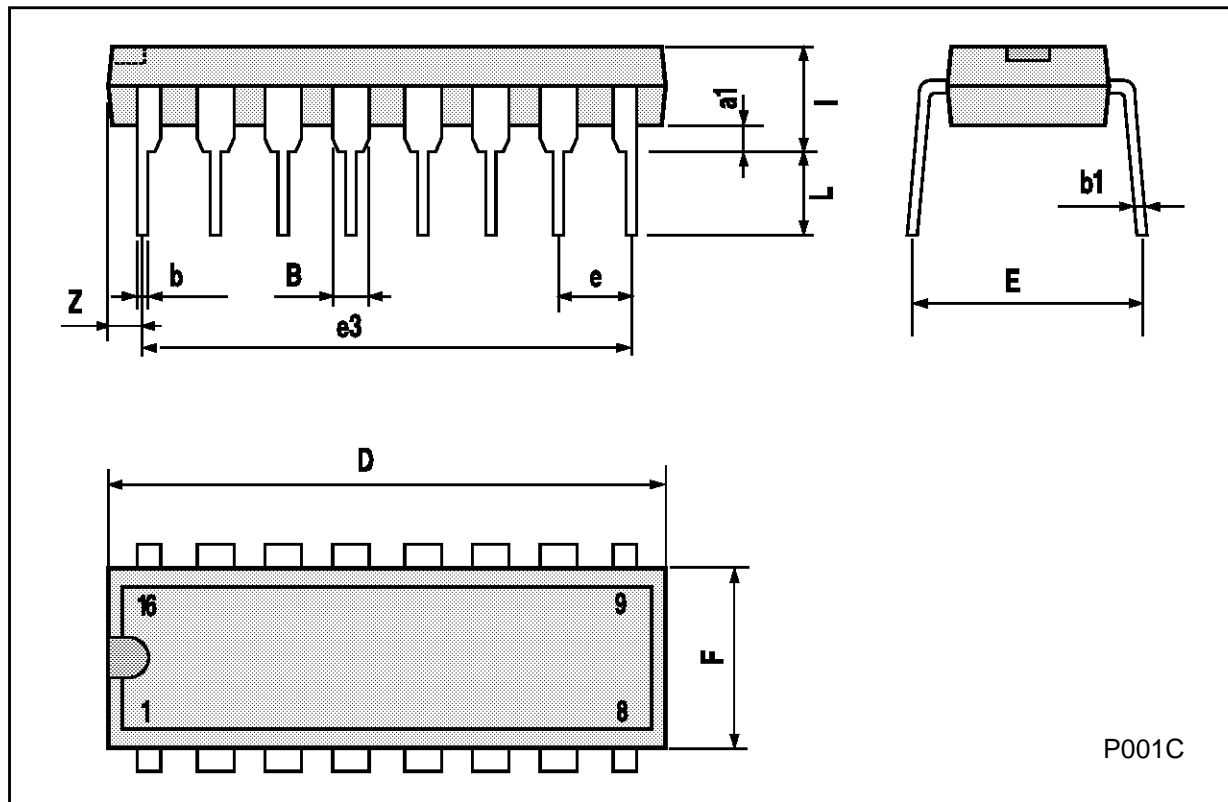

P001C

Ceramic DIP16/1 MECHANICAL DATA

DIM.	mm			inch		
	MIN.	TYP.	MAX.	MIN.	TYP.	MAX.
A			20			0.787
B			7			0.276
D		3.3			0.130	
E	0.38			0.015		
e3		17.78			0.700	
F	2.29		2.79	0.090		0.110
G	0.4		0.55	0.016		0.022
H	1.17		1.52	0.046		0.060
L	0.22		0.31	0.009		0.012
M	0.51		1.27	0.020		0.050
N			10.3			0.406
P	7.8		8.05	0.307		0.317
Q			5.08			0.200

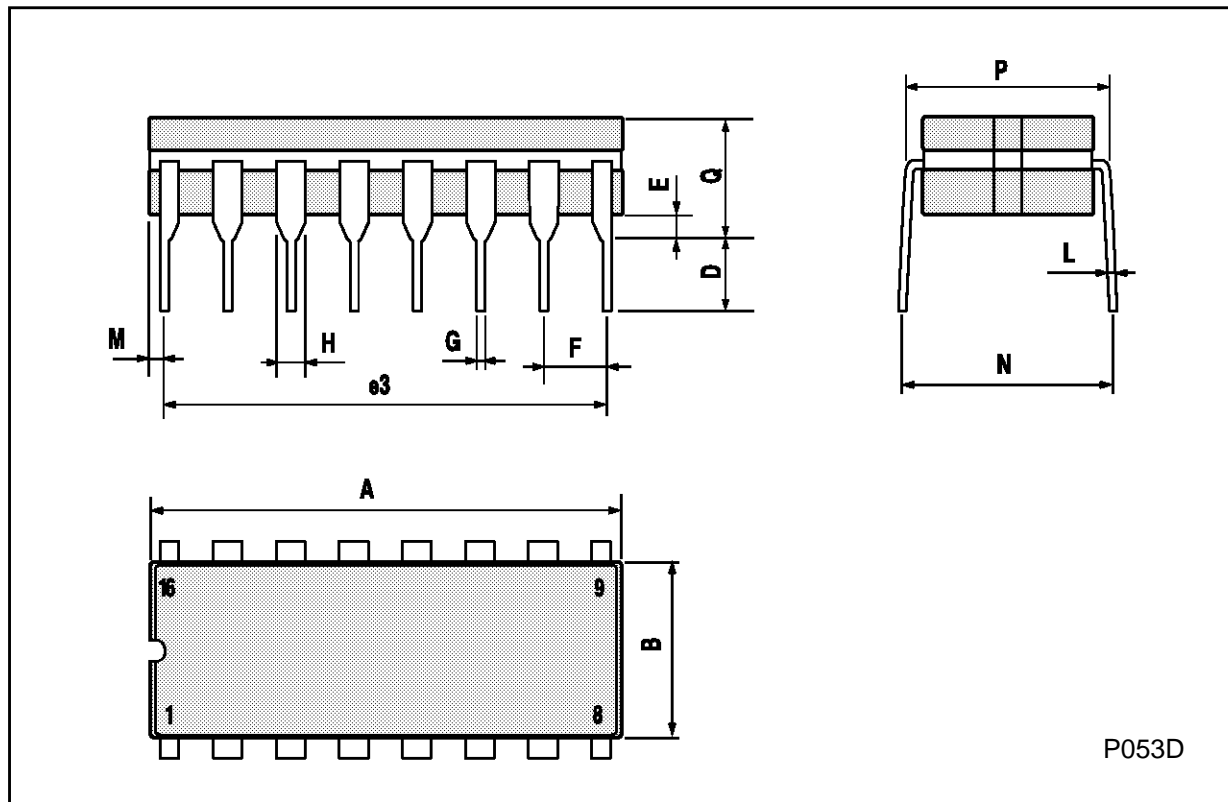

SO16 (Narrow) MECHANICAL DATA

DIM.	mm			inch		
	MIN.	TYP.	MAX.	MIN.	TYP.	MAX.
A			1.75			0.068
a1	0.1		0.2	0.004		0.007
a2			1.65			0.064
b	0.35		0.46	0.013		0.018
b1	0.19		0.25	0.007		0.010
C		0.5			0.019	
c1	45° (typ.)					
D	9.8		10	0.385		0.393
E	5.8		6.2	0.228		0.244
e		1.27			0.050	
e3		8.89			0.350	
F	3.8		4.0	0.149		0.157
G	4.6		5.3	0.181		0.208
L	0.5		1.27	0.019		0.050
M			0.62			0.024
S	8° (max.)					

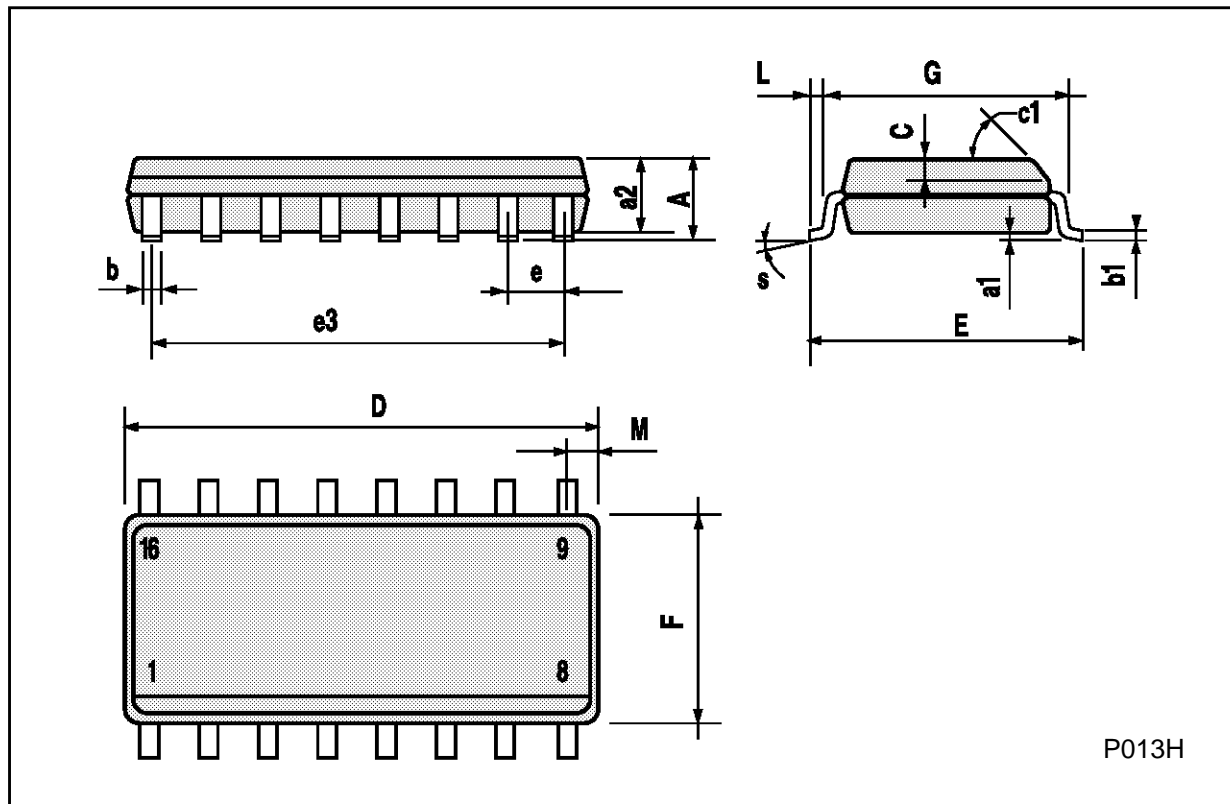

P013H

PLCC20 MECHANICAL DATA

DIM.	mm			inch		
	MIN.	TYP.	MAX.	MIN.	TYP.	MAX.
A	9.78		10.03	0.385		0.395
B	8.89		9.04	0.350		0.356
D	4.2		4.57	0.165		0.180
d1		2.54			0.100	
d2		0.56			0.022	
E	7.37		8.38	0.290		0.330
e		1.27			0.050	
e3		5.08			0.200	
F		0.38			0.015	
G			0.101			0.004
M		1.27			0.050	
M1		1.14			0.045	

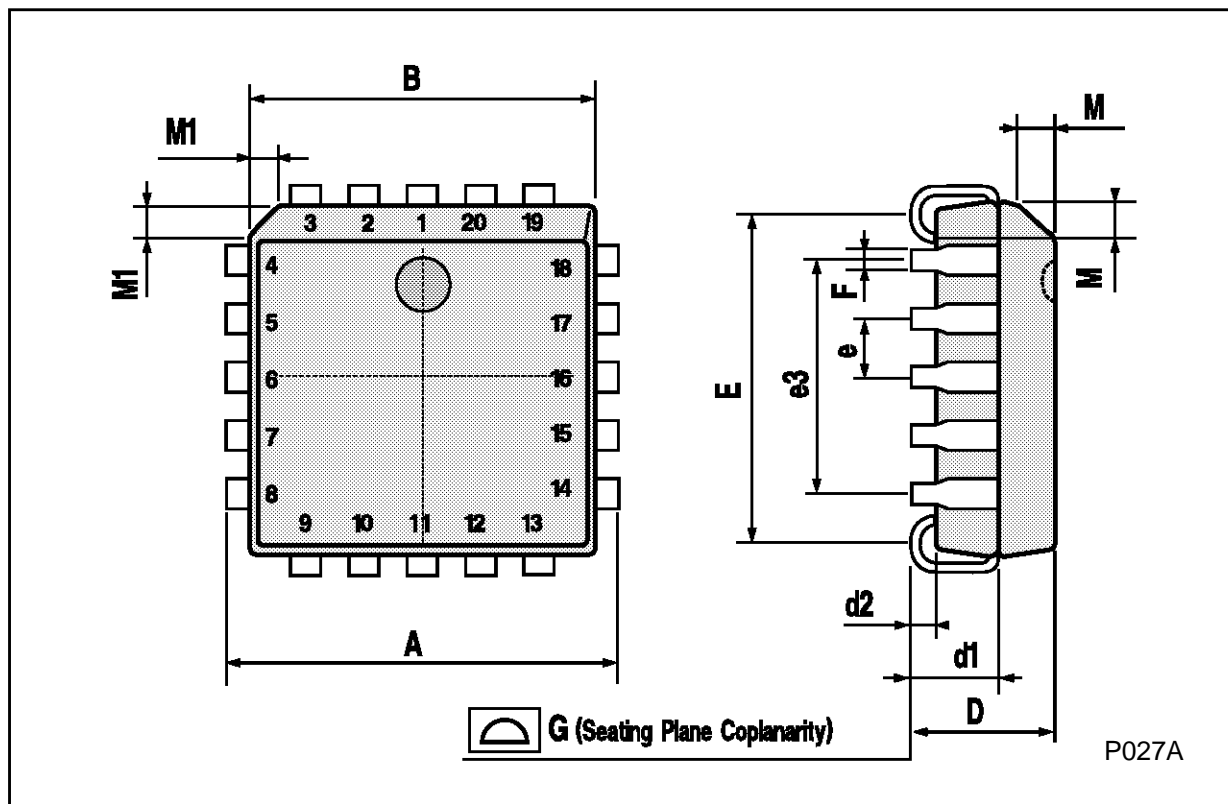

Information furnished is believed to be accurate and reliable. However, SGS-THOMSON Microelectronics assumes no responsibility for the consequences of use of such information nor for any infringement of patents or other rights of third parties which may result from its use. No license is granted by implication or otherwise under any patent or patent rights of SGS-THOMSON Microelectronics. Specifications mentioned in this publication are subject to change without notice. This publication supersedes and replaces all information previously supplied. SGS-THOMSON Microelectronics products are not authorized for use as critical components in life support devices or systems without express written approval of SGS-THOMSON Microelectronics.

© 1994 SGS-THOMSON Microelectronics - All Rights Reserved

SGS-THOMSON Microelectronics GROUP OF COMPANIES
Australia - Brazil - France - Germany - Hong Kong - Italy - Japan - Korea - Malaysia - Malta - Morocco - The Netherlands -
Singapore - Spain - Sweden - Switzerland - Taiwan - Thailand - United Kingdom - U.S.A