

# HD74HC668, HD74HC669

## Synchronous UP/Down Decade Counter Synchronous Up/Down 4-bit binary Counter

REJ03D0638-0200  
(Previous ADE-205-520)  
Rev.2.00  
Mar 30, 2006

### Description

This synchronous presettable decade counter features an internal carry look-ahead for cascading in high-speed counting applications. Synchronous operation is provided by having all flip-flops clocked simultaneously so that the outputs change coincident with each other when so instructed by the count-enable inputs and internal gating. This mode of operation helps eliminate the output counting spikes that are normally associated with asynchronous (ripple-clock) counters.

A buffered clock input triggers the four master-slave flip-flops on the rising (positive going) edge of the clock waveform. This counter is fully programmable; that is, the outputs may each be preset to either level. The load input circuitry allows loading with the carry-enable output of cascaded counters. As loading is synchronous, setting up a low level at the load input disables the counter and causes the outputs to agree with the data inputs after the next clock pulse.

The carry look-ahead circuitry provides for cascading counters for n-bit synchronous applications without additional gating. Instrumental in accomplishing this function are two count enable inputs and a carry output. Both count enable inputs ( $\bar{P}$  and  $\bar{T}$ ) must be low to count. The direction of the count is determined by the level of the up/down input. when the input is high, the counter counts up; when low, it counts down. Input  $\bar{T}$  is fed forward to enable the carry output. The carry output thus enabled will produce a low-level output pulse with a duration approximately equal to the high portion of the  $Q_A$  output when counting up and approximately equal to the low portion of the  $Q_A$  output when counting down. This low level overflow carry pulse can be used to enable successive cascaded stages. Transitions at the enable  $\bar{P}$  or  $\bar{T}$  inputs are allowed regardless of the level of the clock input. All inputs are diode-clamped to minimize transission-line effects, thereby simplifying system design. This counter features a fully independent clock circuit. Changes at control inputs (enable  $\bar{P}$ , Enable  $\bar{T}$ , load, up/down) that will modify the operating mode have no effect until clocking occurs. The function of the counter (whether enabled, disabled, loading, or counting) will be dictated solely by the conditions meeting the stable setup and hold times.

### Features

- High Speed Operation
- High Output Current: Fanout of 10 LSTTL Loads
- Wide Operating Voltage:  $V_{CC} = 2$  to 6 V
- Low Input Current: 1  $\mu$ A max
- Low Quiescent Supply Current:  $I_{CC}$  (static) = 4  $\mu$ A max ( $T_a = 25^\circ\text{C}$ )
- Ordering Information

Part Name	Package Type	Package Code (Previous Code)	Package Abbreviation	Taping Abbreviation (Quantity)
HD74HC669P	DILP-16 pin	PRDP0016AE-B (DP-16FV)	P	—
HD74HC669FPEL	SOP-16 pin (JEITA)	PRSP0016DH-B (FP-16DAV)	FP	EL (2,000 pcs/reel)
HD74HC668RPEL HD74HC669RPEL	SOP-16 pin (JEDEC)	PRSP0016DG-A (FP-16DNV)	RP	EL (1,000 pcs/reel)

Note: Please consult the sales office for the above package availability.

Pin Arrangement

HD74HC668

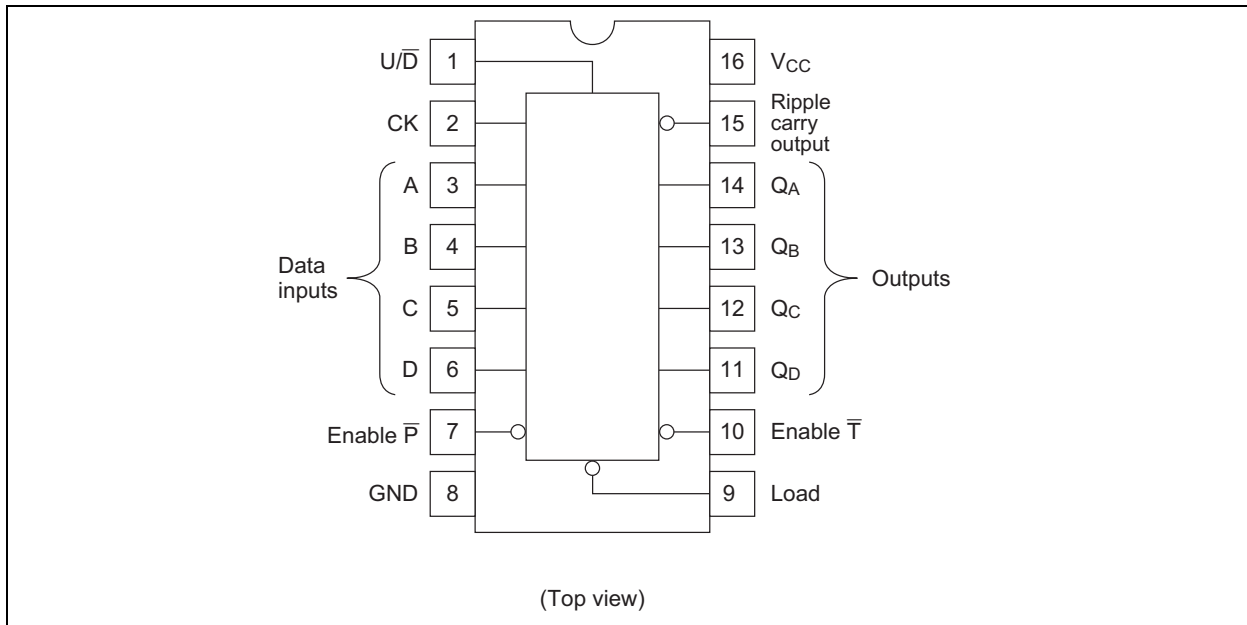

HD74HC669

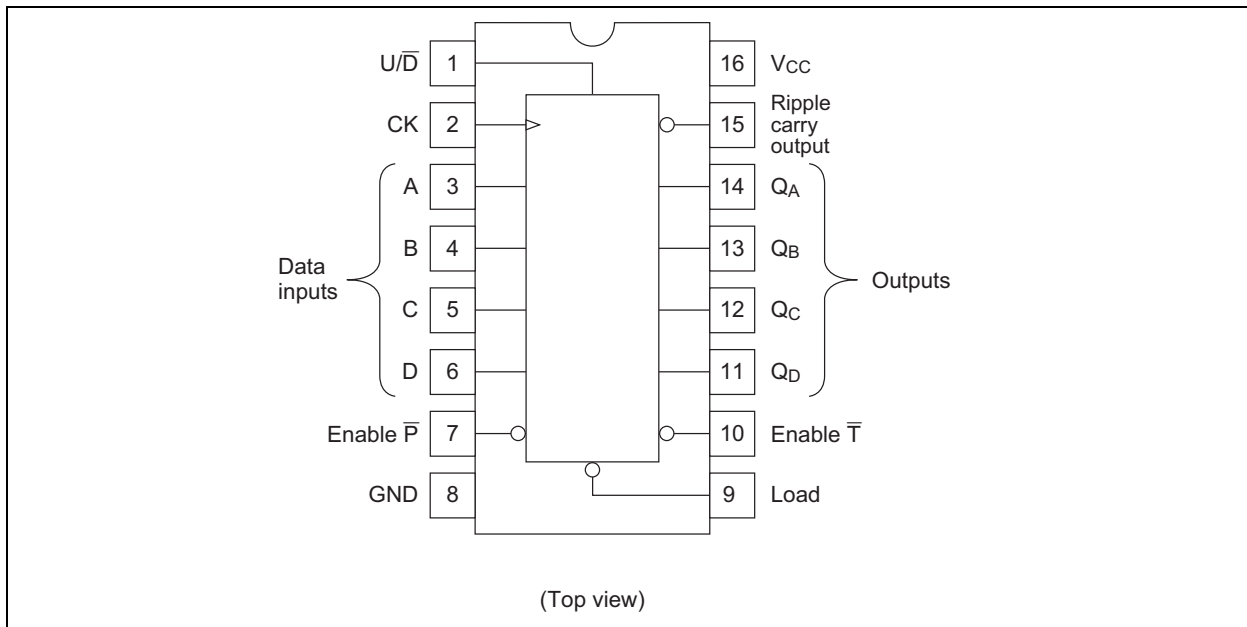

Logic Diagram

HD74HC668

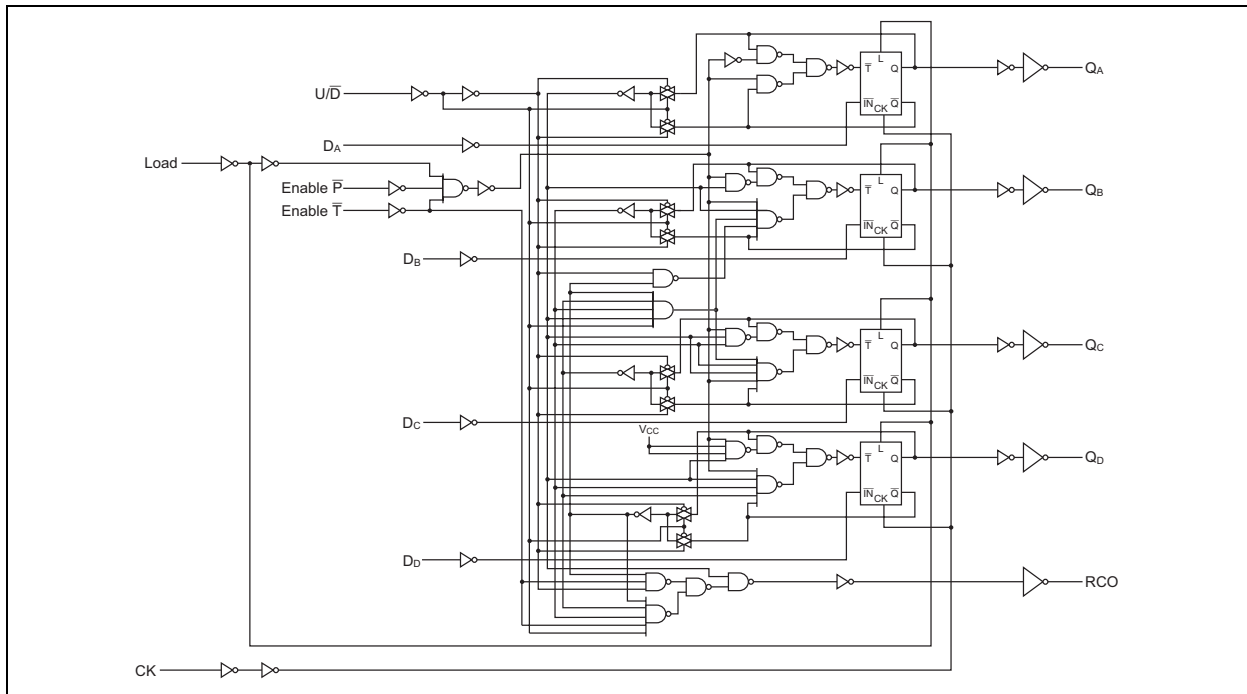

HD74HC669

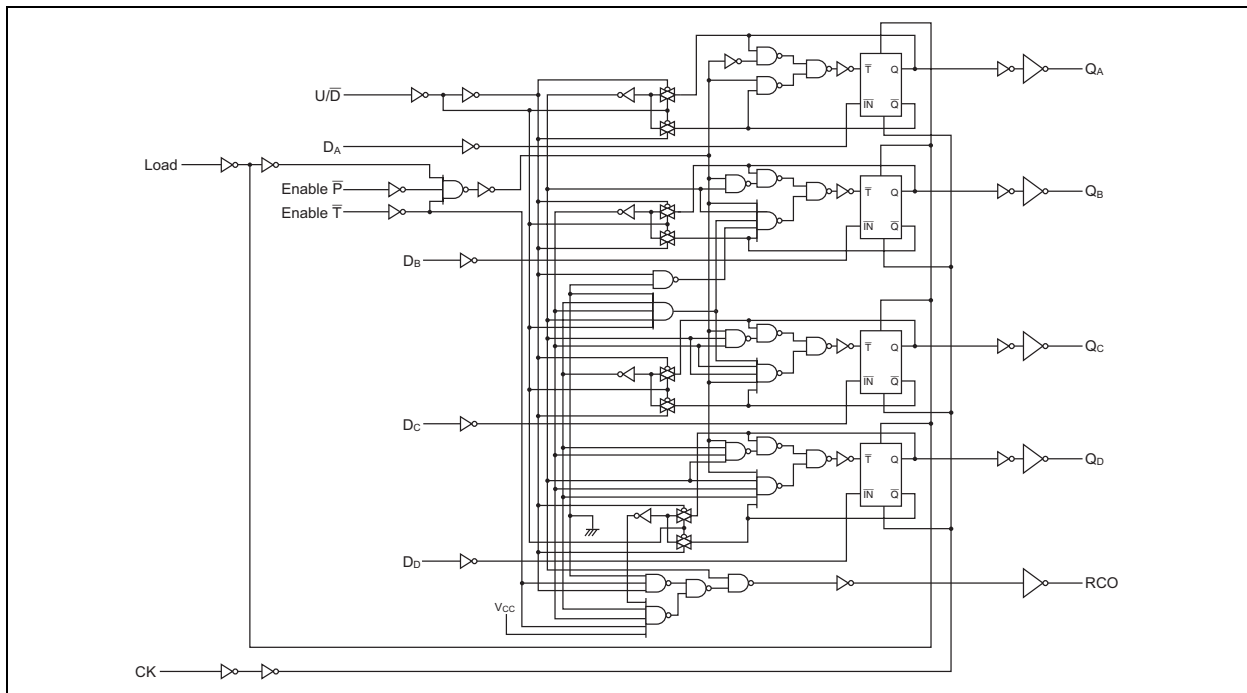

# Timing Chart

## HD74HC668

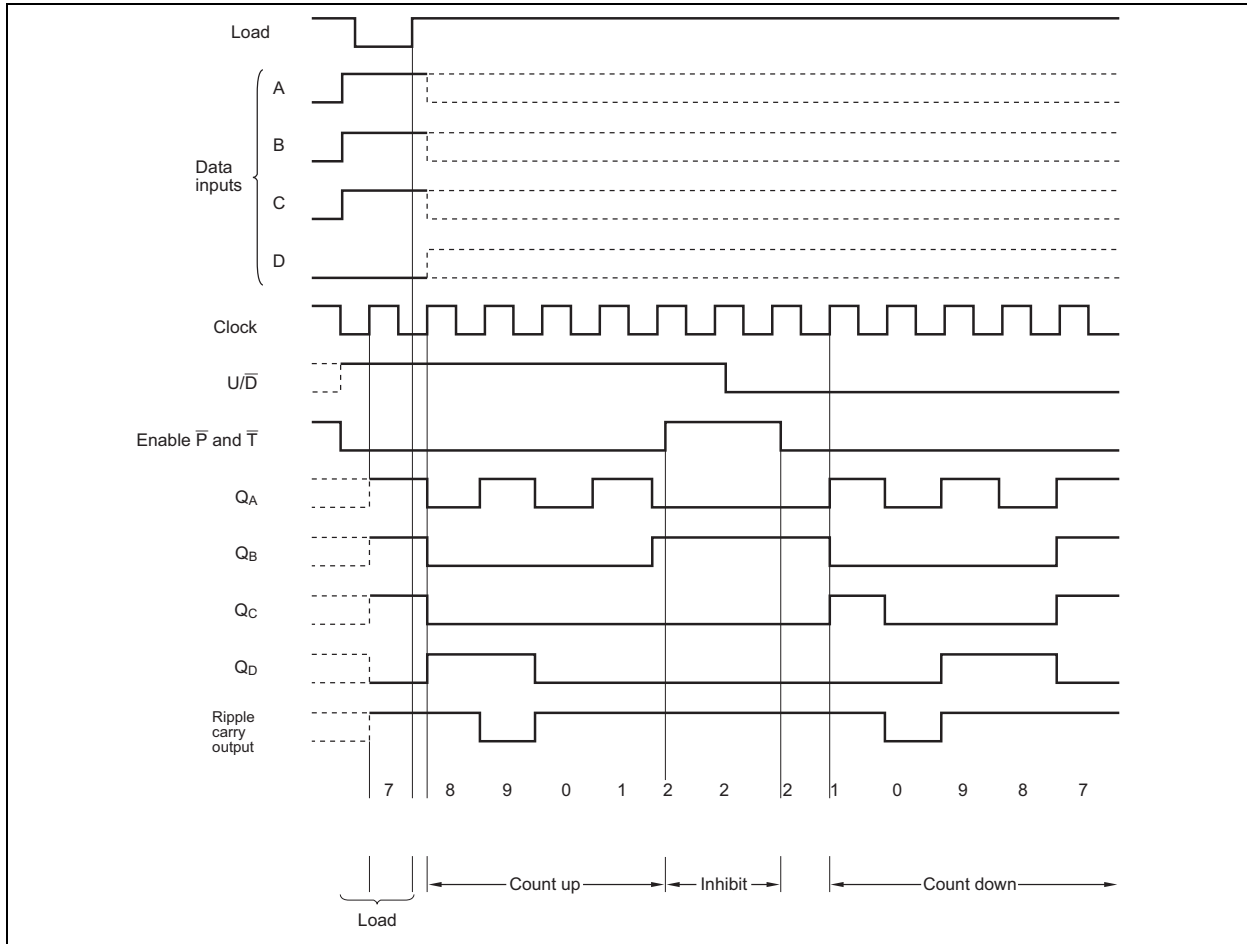

HD74HC669

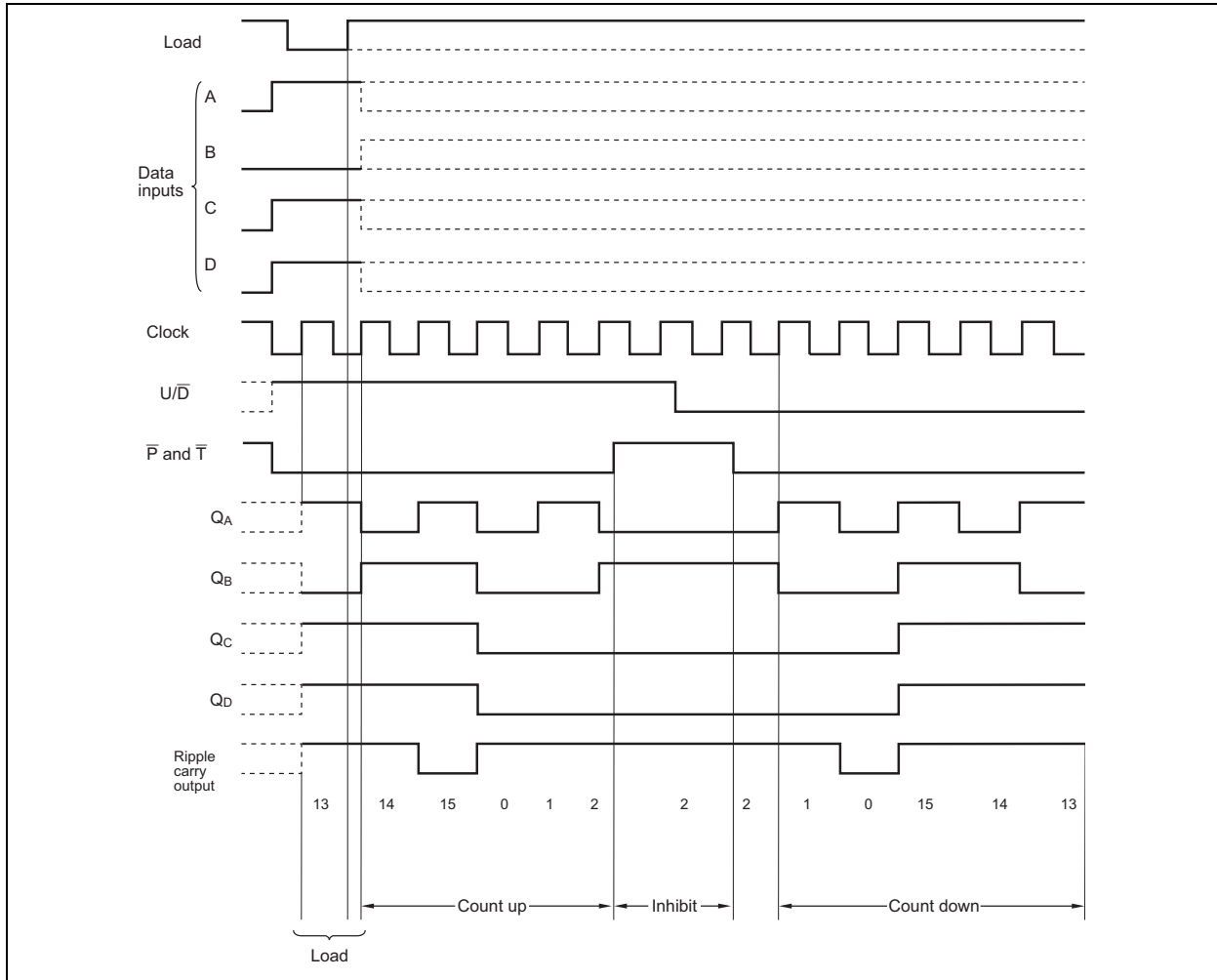

**Absolute Maximum Ratings**

Item	Symbol	Ratings	Unit
Supply voltage range	$V_{CC}$	-0.5 to 7.0	V
Input / Output voltage	$V_{IN}, V_{OUT}$	-0.5 to $V_{CC} + 0.5$	V
Input / Output diode current	$I_{IK}, I_{OK}$	$\pm 20$	mA
Output current	$I_O$	$\pm 25$	mA
$V_{CC}, GND$ current	$I_{CC}$ or $I_{GND}$	$\pm 50$	mA
Power dissipation	$P_T$	500	mW
Storage temperature	$T_{stg}$	-65 to +150	$^{\circ}C$

Note: The absolute maximum ratings are values, which must not individually be exceeded, and furthermore, no two of which may be realized at the same time.

## Recommended Operating Conditions

Item	Symbol	Ratings	Unit	Conditions
Supply voltage	$V_{CC}$	2 to 6	V	
Input / Output voltage	$V_{IN}, V_{OUT}$	0 to $V_{CC}$	V	
Operating temperature	$T_a$	-40 to 85	°C	
Input rise / fall time <sup>*1</sup>	$t_r, t_f$	0 to 1000	ns	$V_{CC} = 2.0\text{ V}$
		0 to 500		$V_{CC} = 4.5\text{ V}$
		0 to 400		$V_{CC} = 6.0\text{ V}$

Note: 1. This item guarantees maximum limit when one input switches.

Waveform: Refer to test circuit of switching characteristics.

## Electrical Characteristics

Item	Symbol	$V_{CC}$ (V)	$T_a = 25^\circ\text{C}$			$T_a = -40\text{ to }+85^\circ\text{C}$		Unit	Test Conditions	
			Min	Typ	Max	Min	Max			
Input voltage	$V_{IH}$	2.0	1.5	—	—	1.5	—	V		
		4.5	3.15	—	—	3.15	—			
		6.0	4.2	—	—	4.2	—			
	$V_{IL}$	2.0	—	—	0.5	—	0.5	V		
		4.5	—	—	1.35	—	1.35			
		6.0	—	—	1.8	—	1.8			
Output voltage	$V_{OH}$	2.0	1.9	2.0	—	1.9	—	V	$V_{in} = V_{IH}$ or $V_{IL}$	$I_{OH} = -20\ \mu\text{A}$
		4.5	4.4	4.5	—	4.4	—			$I_{OH} = -4\ \text{mA}$
		6.0	5.9	6.0	—	5.9	—			$I_{OH} = -5.2\ \text{mA}$
		4.5	4.18	—	—	4.13	—			
		6.0	5.68	—	—	5.63	—			
	$V_{OL}$	2.0	—	0.0	0.1	—	0.1	V	$V_{in} = V_{IH}$ or $V_{IL}$	$I_{OL} = 20\ \mu\text{A}$
		4.5	—	0.0	0.1	—	0.1			
		6.0	—	0.0	0.1	—	0.1			
		4.5	—	—	0.26	—	0.33			$I_{OL} = 4\ \text{mA}$
		6.0	—	—	0.26	—	0.33			$I_{OL} = 5.2\ \text{mA}$
Input current	$I_{in}$	6.0	—	—	$\pm 0.1$	—	$\pm 1.0$	$\mu\text{A}$	$V_{in} = V_{CC}$ or GND	
Quiescent supply current	$I_{CC}$	6.0	—	—	4.0	—	40	$\mu\text{A}$	$V_{in} = V_{CC}$ or GND, $I_{out} = 0\ \mu\text{A}$	

Switching Characteristics ( $C_L = 50 \text{ pF}$ , Input  $t_r = t_f = 6 \text{ ns}$ )

Item	Symbol	$V_{CC}$ (V)	$T_a = 25^\circ\text{C}$			$T_a = -40 \text{ to } +85^\circ\text{C}$		Unit	Test Conditions
			Min	Typ	Max	Min	Max		
Maximum clock Frequency	$f_{\max}$	2.0	—	—	5	—	4	MHz	
		4.5	—	—	27	—	21		
		6.0	—	—	32	—	25		
Propagation delay time	$t_{PLH}$ $t_{PHL}$	2.0	—	—	200	—	250	ns	Clock to Ripple carry out
		4.5	—	—	40	—	50		
		6.0	—	—	34	—	43		
	$t_{PLH}$ $t_{PHL}$	2.0	—	—	225	—	280	ns	Clock to Q
		4.5	—	—	45	—	56		
		6.0	—	—	38	—	48		
	$t_{PLH}$ $t_{PHL}$	2.0	—	—	150	—	190	ns	Enable $\bar{T}$ to Ripple carry out
		4.5	—	—	30	—	38		
		6.0	—	—	26	—	33		
	$t_{PLH}$ $t_{PHL}$	2.0	—	—	200	—	250	ns	$U/\bar{D}$ to Ripple carry out
		4.5	—	—	40	—	50		
		6.0	—	—	34	—	43		
Pulse width	$t_w$	2.0	80	—	—	100	—	ns	
		4.5	16	—	—	20	—		
		6.0	14	—	—	17	—		
Setup time	$t_{su}$	2.0	100	—	—	125	—	ns	Data to Clock
		4.5	20	—	—	25	—		
		6.0	17	—	—	21	—		
	$t_{su}$	2.0	150	—	—	190	—	ns	Enable $\bar{P}$ , $\bar{T}$ to Clock
		4.5	30	—	—	38	—		
		6.0	26	—	—	33	—		
	$t_{su}$	2.0	150	—	—	190	—	ns	Loadk to Clock
		4.5	30	—	—	38	—		
		6.0	26	—	—	33	—		
	$t_{su}$	2.0	150	—	—	190	—	ns	$U/\bar{D}$ to Clock
		4.5	30	—	—	38	—		
		6.0	26	—	—	33	—		
Hold time	$t_h$	2.0	5	—	—	5	—	ns	
		4.5	5	—	—	5	—		
		6.0	5	—	—	5	—		
Output rise/fall time	$t_{TLH}$ $t_{THL}$	2.0	—	—	75	—	95	ns	
		4.5	—	5	15	—	19		
		6.0	—	—	13	—	16		
Input capacitance	$C_{in}$	—	—	5	10	—	10	pF	

Test Circuit

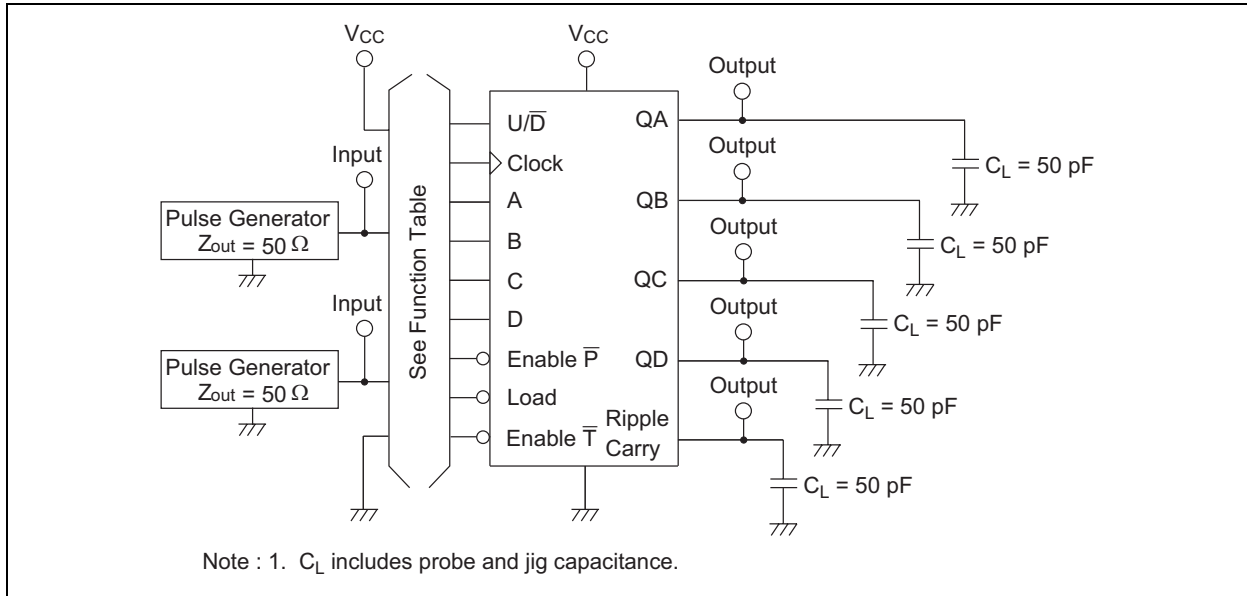



Package Dimensions

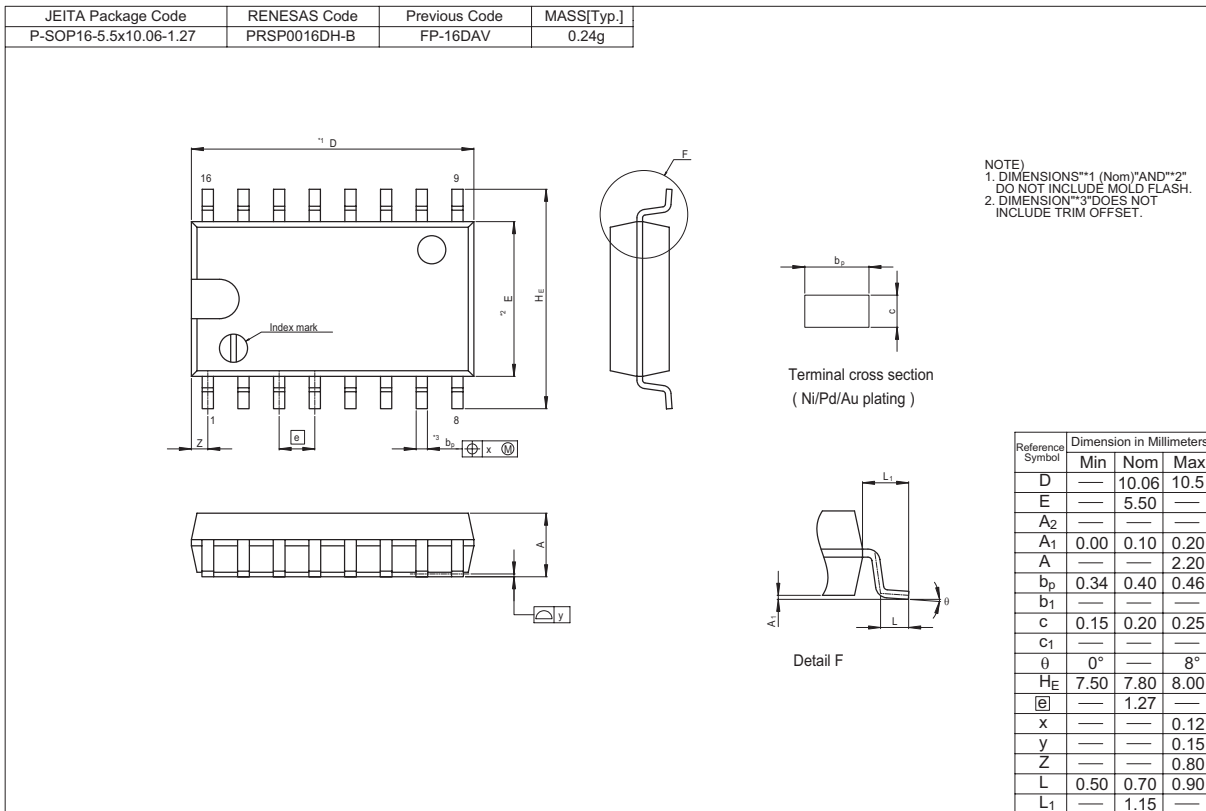
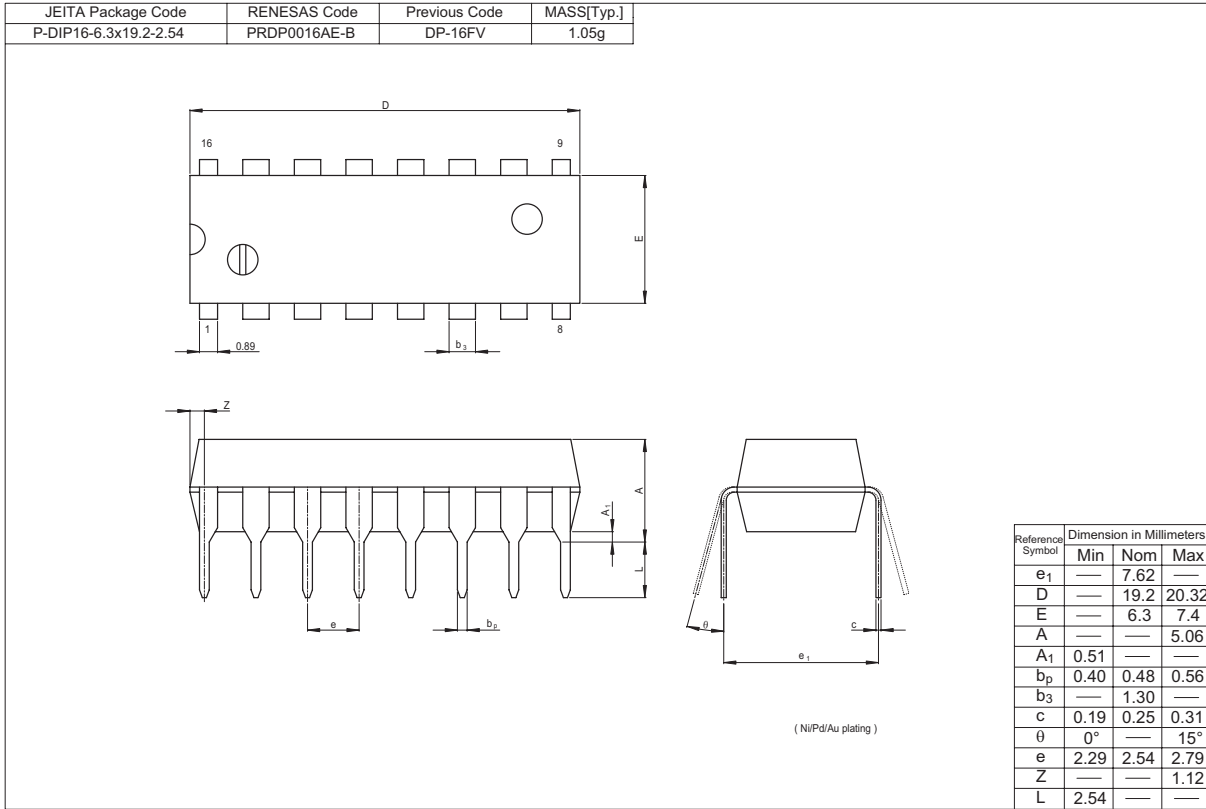

# HD74HC668, HD74HC669

JEITA Package Code	RENESAS Code	Previous Code	MASS[Typ.]
P-SOP16-3.95x9.9-1.27	PRSP0016DG-A	FP-16DNV	0.15g

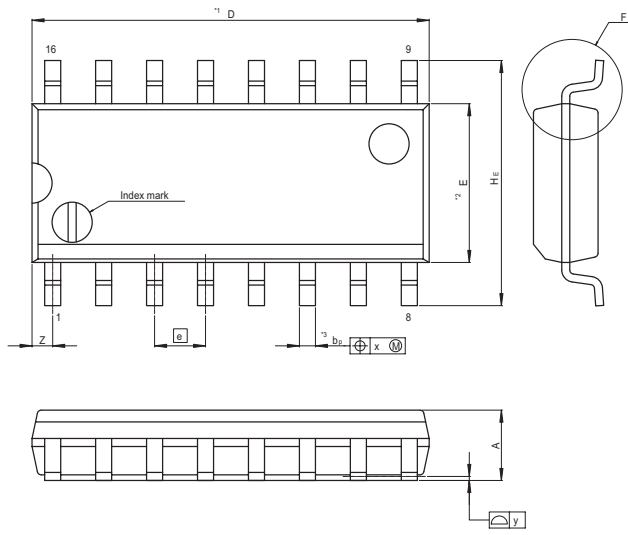

NOTE)  
 1. DIMENSIONS "1 (Nom)" AND "2" DO NOT INCLUDE MOLD FLASH.  
 2. DIMENSION "3" DOES NOT INCLUDE TRIM OFFSET.

Terminal cross section  
 ( Ni/Pd/Au plating )

Reference Symbol	Dimension in Millimeters		
	Min	Nom	Max
D	—	9.90	10.30
E	—	3.95	—
A <sub>2</sub>	—	—	—
A <sub>1</sub>	0.10	0.14	0.25
A	—	—	1.75
b <sub>D</sub>	0.34	0.40	0.46
b <sub>1</sub>	—	—	—
c	0.15	0.20	0.25
c <sub>1</sub>	—	—	—
$\theta$	0°	—	8°
H <sub>E</sub>	5.80	6.10	6.20
$\phi$	—	1.27	—
x	—	—	0.25
y	—	—	0.15
Z	—	—	0.635
L	0.40	0.60	1.27
L <sub>1</sub>	—	1.08	—

## Renesas Technology Corp. Sales Strategic Planning Div. Nippon Bldg., 2-6-2, Ohte-machi, Chiyoda-ku, Tokyo 100-0004, Japan

Keep safety first in your circuit designs!

1. Renesas Technology Corp. puts the maximum effort into making semiconductor products better and more reliable, but there is always the possibility that trouble may occur with them. Trouble with semiconductors may lead to personal injury, fire or property damage.  
Remember to give due consideration to safety when making your circuit designs, with appropriate measures such as (i) placement of substitutive, auxiliary circuits, (ii) use of nonflammable material or (iii) prevention against any malfunction or mishap.

Notes regarding these materials

1. These materials are intended as a reference to assist our customers in the selection of the Renesas Technology Corp. product best suited to the customer's application; they do not convey any license under any intellectual property rights, or any other rights, belonging to Renesas Technology Corp. or a third party.
2. Renesas Technology Corp. assumes no responsibility for any damage, or infringement of any third-party's rights, originating in the use of any product data, diagrams, charts, programs, algorithms, or circuit application examples contained in these materials.
3. All information contained in these materials, including product data, diagrams, charts, programs and algorithms represents information on products at the time of publication of these materials, and are subject to change by Renesas Technology Corp. without notice due to product improvements or other reasons. It is therefore recommended that customers contact Renesas Technology Corp. or an authorized Renesas Technology Corp. product distributor for the latest product information before purchasing a product listed herein.  
The information described here may contain technical inaccuracies or typographical errors.  
Renesas Technology Corp. assumes no responsibility for any damage, liability, or other loss rising from these inaccuracies or errors.  
Please also pay attention to information published by Renesas Technology Corp. by various means, including the Renesas Technology Corp. Semiconductor home page (<http://www.renesas.com>).
4. When using any or all of the information contained in these materials, including product data, diagrams, charts, programs, and algorithms, please be sure to evaluate all information as a total system before making a final decision on the applicability of the information and products. Renesas Technology Corp. assumes no responsibility for any damage, liability or other loss resulting from the information contained herein.
5. Renesas Technology Corp. semiconductors are not designed or manufactured for use in a device or system that is used under circumstances in which human life is potentially at stake. Please contact Renesas Technology Corp. or an authorized Renesas Technology Corp. product distributor when considering the use of a product contained herein for any specific purposes, such as apparatus or systems for transportation, vehicular, medical, aerospace, nuclear, or undersea repeater use.
6. The prior written approval of Renesas Technology Corp. is necessary to reprint or reproduce in whole or in part these materials.
7. If these products or technologies are subject to the Japanese export control restrictions, they must be exported under a license from the Japanese government and cannot be imported into a country other than the approved destination.  
Any diversion or reexport contrary to the export control laws and regulations of Japan and/or the country of destination is prohibited.
8. Please contact Renesas Technology Corp. for further details on these materials or the products contained therein.



### RENESAS SALES OFFICES

<http://www.renesas.com>

Refer to "<http://www.renesas.com/en/network>" for the latest and detailed information.

#### Renesas Technology America, Inc.

450 Holger Way, San Jose, CA 95134-1368, U.S.A  
Tel: <1> (408) 382-7500, Fax: <1> (408) 382-7501

#### Renesas Technology Europe Limited

Dukes Meadow, Millboard Road, Bourne End, Buckinghamshire, SL8 5FH, U.K.  
Tel: <44> (1628) 585-100, Fax: <44> (1628) 585-900

#### Renesas Technology (Shanghai) Co., Ltd.

Unit 204, 205, AZIACenter, No.1233 Lujiazui Ring Rd, Pudong District, Shanghai, China 200120  
Tel: <86> (21) 5877-1818, Fax: <86> (21) 6887-7898

#### Renesas Technology Hong Kong Ltd.

7th Floor, North Tower, World Finance Centre, Harbour City, 1 Canton Road, Tsimshatsui, Kowloon, Hong Kong  
Tel: <852> 2265-6688, Fax: <852> 2730-6071

#### Renesas Technology Taiwan Co., Ltd.

10th Floor, No.99, Fushing North Road, Taipei, Taiwan  
Tel: <886> (2) 2715-2888, Fax: <886> (2) 2713-2999

#### Renesas Technology Singapore Pte. Ltd.

1 Harbour Front Avenue, #06-10, Keppel Bay Tower, Singapore 098632  
Tel: <65> 6213-0200, Fax: <65> 6278-8001

#### Renesas Technology Korea Co., Ltd.

Kukje Center Bldg. 18th Fl., 191, 2-ka, Hangang-ro, Yongsan-ku, Seoul 140-702, Korea  
Tel: <82> (2) 796-3115, Fax: <82> (2) 796-2145

#### Renesas Technology Malaysia Sdn. Bhd

Unit 906, Block B, Menara Amcorp, Amcorp Trade Centre, No.18, Jalan Persiaran Barat, 46050 Petaling Jaya, Selangor Darul Ehsan, Malaysia  
Tel: <603> 7955-9390, Fax: <603> 7955-9510