

---

# HD74LVC74

Dual D-type Flip Flops with Preset and Clear

# HITACHI

ADE-205-066C(Z)

Rev.3

September 1995

---

## Description

The HD74LVC74 has independent data, preset, clear, and clock inputs Q and  $\bar{Q}$  outputs in a 14 pin package. The logic level present at the data input is transferred to the output during the positive going transition of the clock pulse. Preset and clear are independent of the clock and accomplished by a low level at the appropriate input. Low voltage and high speed operation is suitable at the battery drive product (note type personal computer) and low power consumption extends the life of a battery for long time operation.

## Features

- $V_{CC} = 2.0 \text{ V to } 5.5 \text{ V}$
- All inputs  $V_{IH} (\text{Max.}) = 5.5 \text{ V} (@V_{CC} = 0 \text{ V to } 5.5 \text{ V})$
- Typical  $V_{OL}$  ground bounce  $< 0.8 \text{ V} (@V_{CC} = 3.3 \text{ V}, T_a = 25^\circ\text{C})$
- Typical  $V_{OH}$  undershoot  $> 2.0 \text{ V} (@V_{CC} = 3.3 \text{ V}, T_a = 25^\circ\text{C})$
- High output current  $\pm 24 \text{ mA} (@V_{CC} = 3.0 \text{ V to } 5.5 \text{ V})$



# HD74LVC74

## Function Table

Inputs				Outputs	
PR	CLR	CK	D	Q	$\bar{Q}$
L	H	X	X	H	L
H	L	X	X	L	H
L	L	X	X	H <sup>1</sup>	H <sup>1</sup>
H	H	↑	H	H	L
H	H	↑	L	L	H
H	H	L	X	Q <sub>0</sub>	$\bar{Q}$ <sub>0</sub>
H	H	H	X	Q <sub>0</sub>	$\bar{Q}$ <sub>0</sub>
H	H	↓	X	Q <sub>0</sub>	$\bar{Q}$ <sub>0</sub>

H: High level

L: Low level

X: Immaterial

↓: High to Low transition

↑: Low to high transition

Q<sub>0</sub>: Level to Q before the indicated steady input conditions were established.

Note: 1. Q and  $\bar{Q}$  will remain high as long as preset and clear are low, but Q and  $\bar{Q}$  are unpredictable, if preset and clear go high simultaneously.

## Pin Arrangement

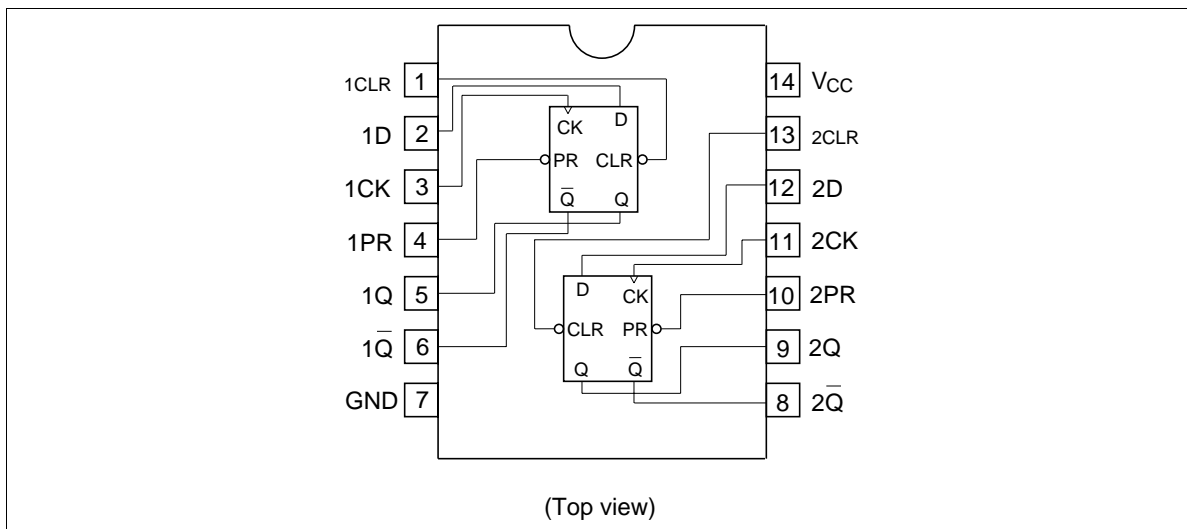

**Absolute Maximum Ratings**

Item	Symbol	Ratings	Unit	Conditions
Supply voltage	$V_{CC}$	-0.5 to 6.0	V	
Input diode current	$I_{IK}$	-50	mA	$V_I = -0.5$ V
Input voltage	$V_I$	-0.5 to 6.0	V	
Output diode current	$I_{OK}$	-50	mA	$V_O = -0.5$ V
		50	mA	$V_O = V_{CC} + 0.5$ V
Output voltage	$V_O$	-0.5 to $V_{CC} + 0.5$ V		
Output current	$I_O$	$\pm 50$	mA	
$V_{CC}$ , GND current / pin	$I_{CC}$ or $I_{GND}$	100	mA	
Storage temperature	Tstg	-65 to +150	°C	

Note: The absolute maximum ratings are values which must not individually be exceeded, and furthermore, no two of which may be realized at the same time.

**Recommended Operating Conditions**

Item	Symbol	Ratings	Unit	Conditions
Supply voltage	$V_{CC}$	1.5 to 5.5	V	Data retention
		2.0 to 5.5	V	At operation
Input / output voltage	$V_I$	0 to 5.5	V	PR, CLR, CK, D
	$V_O$	0 to $V_{CC}$	V	Q, $\bar{Q}$
Operating temperature	Ta	-40 to 85	°C	
Output current	$I_{OH}$	-12	mA	$V_{CC} = 2.7$ V
		-24 <sup>*2</sup>	mA	$V_{CC} = 3.0$ V to 5.5 V
	$I_{OL}$	12	mA	$V_{CC} = 2.7$ V
		24 <sup>*2</sup>	mA	$V_{CC} = 3.0$ V to 5.5 V
Input rise / fall time <sup>*1</sup>	$t_r, t_f$	10	ns/V	

Notes: 1. This item guarantees maximum limit when one input switches.

Waveform : Refer to test circuit of switching characteristics.

2. duty cycle  $\leq 50\%$

## HD74LVC74

### Electrical Characteristics

Item	Symbol	$V_{CC}$ (V)	$T_a = -40 \text{ to } 85^\circ\text{C}$		Unit	Test Conditions
			Min	Max		
Input voltage	$V_{IH}$	2.7 to 3.6	2.0	—	V	
		4.5 to 5.5	$V_{CC} \times 0.7$	—	V	
	$V_{IL}$	2.7 to 3.6	—	0.8	V	
		4.5 to 5.5	—	$V_{CC} \times 0.3$	V	
Output voltage	$V_{OH}$	2.7 to 5.5	$V_{CC} - 0.2$	—	V	$I_{OH} = -100 \mu\text{A}$
		2.7	2.2	—	V	$I_{OH} = -12 \text{ mA}$
		3.0	2.4	—	V	
		3.0	2.0	—	V	$I_{OH} = -24 \text{ mA}$
		4.5	3.8	—	V	
	$V_{OL}$	2.7 to 5.5	—	0.2	V	$I_{OL} = 100 \mu\text{A}$
		2.7	—	0.4	V	$I_{OL} = 12 \text{ mA}$
		3.0	—	0.55	V	$I_{OL} = 24 \text{ mA}$
		4.5	—	0.55	V	
Input current	$I_{IN}$	0 to 5.5	—	$\pm 5.0$	$\mu\text{A}$	$V_{IN} = 5.5 \text{ V or GND}$
Quiescent supply current	$I_{CC}$	5.5	—	20	$\mu\text{A}$	$V_{IN} = V_{CC} \text{ or GND}$
	$\Delta I_{CC}$	3.0 to 3.6	—	500	$\mu\text{A}$	$V_{IN} = \text{one input at } (V_{CC} - 0.6)\text{V}, \text{ other inputs at } V_{CC} \text{ or GND}$

**Switching Characteristics**

Item	Symbol	V <sub>CC</sub> (V)	Ta = -40 to 85°C			Unit	From (Input)	To (Output)
			Min	Typ	Max			
Maximum clock frequency	f <sub>max</sub>	2.7	150.0	—	—	MHz		
		3.3±0.3	150.0	—	—	MHz		
		5.0±0.5	150.0	—	—	MHz		
Propagation delay time	t <sub>PLH</sub>	2.7	—	6.0	9.0	ns	CLK	Q, $\bar{Q}$
		3.3±0.3	1.5	5.0	8.0	ns		
		5.0±0.5	—	4.0	6.5	ns		
	t <sub>PHL</sub>	2.7	—	6.5	9.0	ns	PR or CLR	Q, $\bar{Q}$
		3.3±0.3	1.5	5.0	8.0	ns		
		5.0±0.5	—	4.0	6.5	ns		
Setup time	t <sub>su</sub>	2.7	4.0	—	—	ns		
		3.3±0.3	3.0	—	—	ns		
		5.0±0.5	3.0	—	—	ns		
Hold time	t <sub>h</sub>	2.7	2.0	—	—	ns		
		3.3±0.3	2.0	—	—	ns		
		5.0±0.5	2.0	—	—	ns		
Pulse width	t <sub>w</sub>	2.7	4.0	—	—	ns	CK	
		3.3±0.3	4.0	—	—	ns		
		5.0±0.5	4.0	—	—	ns		
	t <sub>w</sub>	2.7	6.0	—	—	ns	PR or CLR	
		3.3±0.3	5.0	—	—	ns		
		5.0±0.5	4.0	—	—	ns		
Recovery time	t <sub>rec</sub>	2.7	3.0	—	—	ns		
		3.3±0.3	2.0	—	—	ns		
		5.0±0.5	2.0	—	—	ns		
Input capacitance	C <sub>IN</sub>	2.7	—	3.0	—	pF		
Output capacitance	C <sub>O</sub>	2.7	—	15.0	—	pF		

# HD74LVC74

## Test Circuit

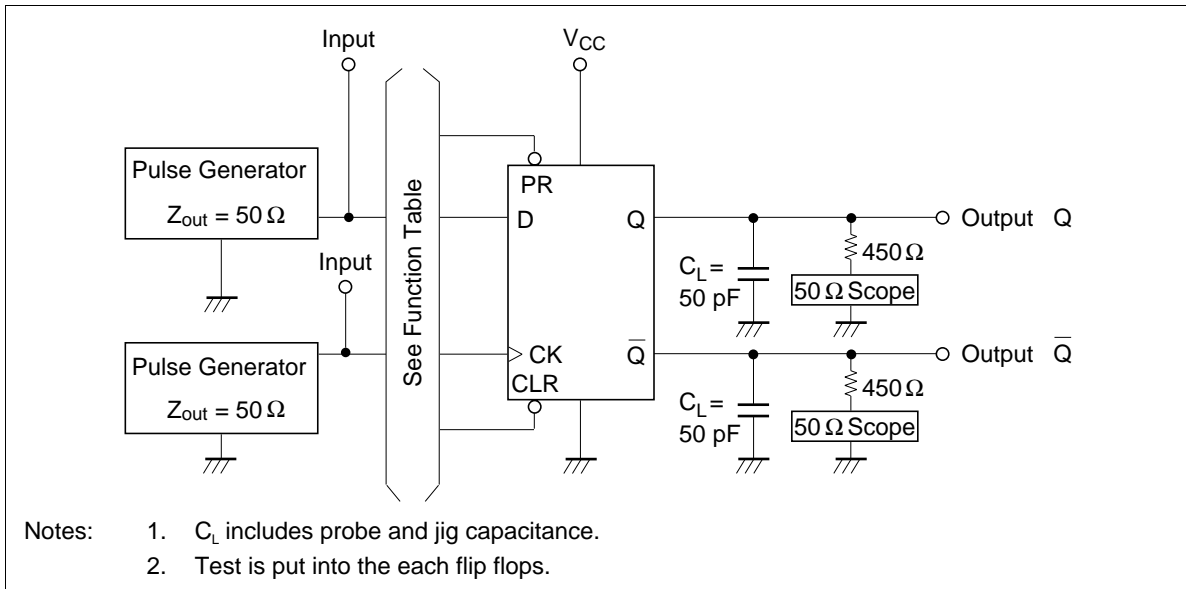

## Waveforms

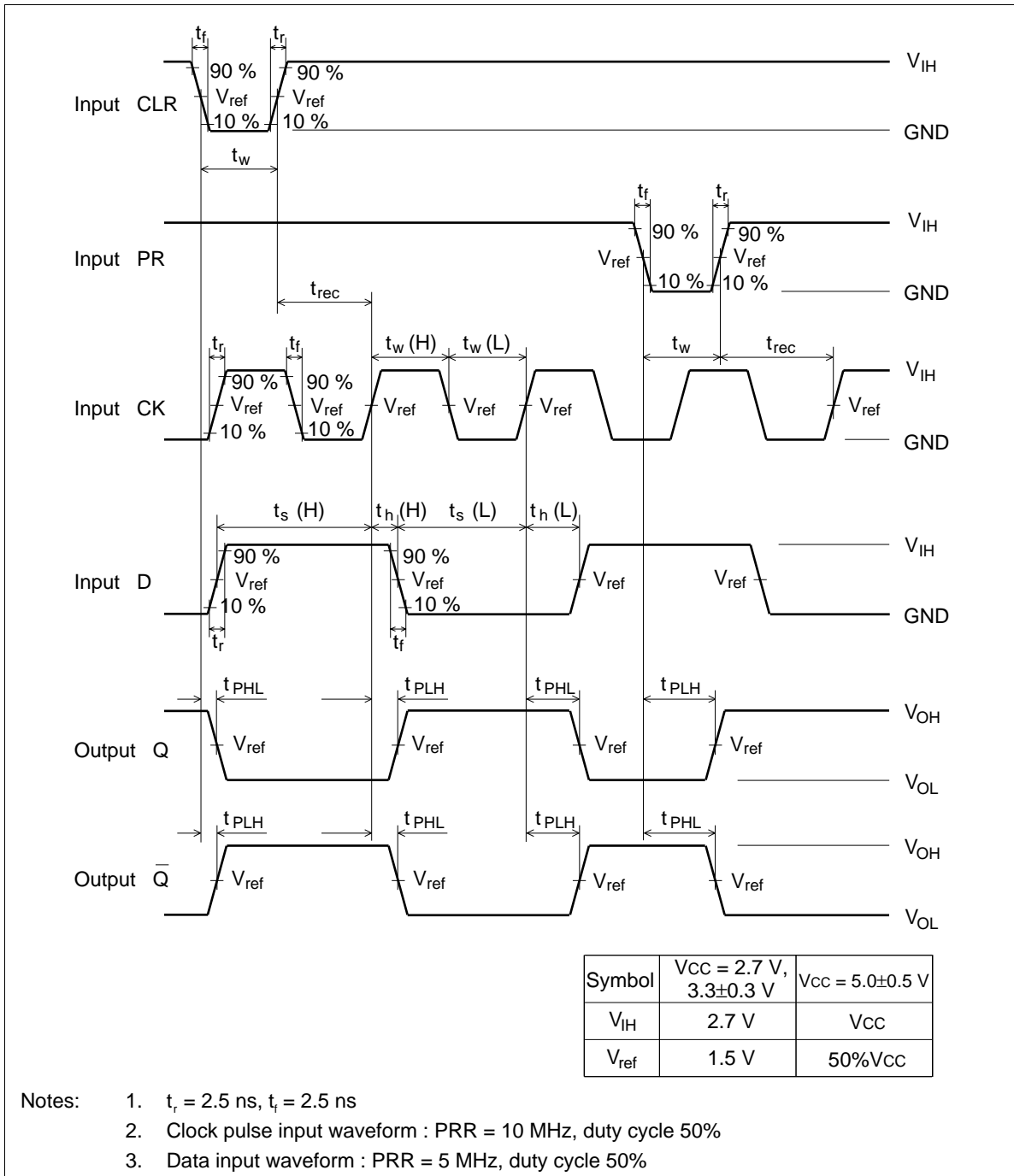

Unit: mm

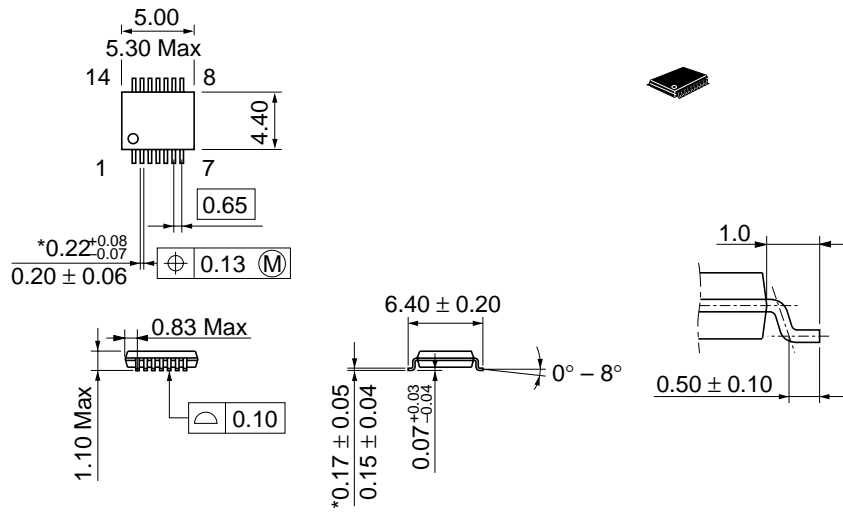

\*Dimension including the plating thickness  
Base material dimension

Hitachi Code	TTP-14D
JEDEC	—
EIAJ	—
Weight (reference value)	0.05 g



---

---

## Cautions

1. Hitachi neither warrants nor grants licenses of any rights of Hitachi's or any third party's patent, copyright, trademark, or other intellectual property rights for information contained in this document. Hitachi bears no responsibility for problems that may arise with third party's rights, including intellectual property rights, in connection with use of the information contained in this document.
2. Products and product specifications may be subject to change without notice. Confirm that you have received the latest product standards or specifications before final design, purchase or use.
3. Hitachi makes every attempt to ensure that its products are of high quality and reliability. However, contact Hitachi's sales office before using the product in an application that demands especially high quality and reliability or where its failure or malfunction may directly threaten human life or cause risk of bodily injury, such as aerospace, aeronautics, nuclear power, combustion control, transportation, traffic, safety equipment or medical equipment for life support.
4. Design your application so that the product is used within the ranges guaranteed by Hitachi particularly for maximum rating, operating supply voltage range, heat radiation characteristics, installation conditions and other characteristics. Hitachi bears no responsibility for failure or damage when used beyond the guaranteed ranges. Even within the guaranteed ranges, consider normally foreseeable failure rates or failure modes in semiconductor devices and employ systemic measures such as fail-safes, so that the equipment incorporating Hitachi product does not cause bodily injury, fire or other consequential damage due to operation of the Hitachi product.
5. This product is not designed to be radiation resistant.
6. No one is permitted to reproduce or duplicate, in any form, the whole or part of this document without written approval from Hitachi.
7. Contact Hitachi's sales office for any questions regarding this document or Hitachi semiconductor products.

---

---

# HITACHI

## Hitachi, Ltd.

Semiconductor & Integrated Circuits.

Nippon Bldg., 2-6-2, Ohte-machi, Chiyoda-ku, Tokyo 100-0004, Japan  
Tel: Tokyo (03) 3270-2111 Fax: (03) 3270-5109

URL      North America      : <http://semiconductor.hitachi.com/>  
             Europe                : <http://www.hitachi-eu.com/hel/ecg>  
             Asia (Singapore)      : <http://www.has.hitachi.com.sg/grp3/sicd/index.htm>  
             Asia (Taiwan)         : [http://www.hitachi.com.tw/E/Product/SICD\\_Frame.htm](http://www.hitachi.com.tw/E/Product/SICD_Frame.htm)  
             Asia (HongKong)      : <http://www.hitachi.com.hk/eng/bo/grp3/index.htm>  
             Japan                    : <http://www.hitachi.co.jp/Sicd/indx.htm>

## For further information write to:

Hitachi Semiconductor  
(America) Inc.  
179 East Tasman Drive,  
San Jose, CA 95134  
Tel: <1> (408) 433-1990  
Fax: <1> (408) 433-0223

Hitachi Europe GmbH  
Electronic components Group  
Dornacher StraÙe 3  
D-85622 Feldkirchen, Munich  
Germany  
Tel: <49> (89) 9 9180-0  
Fax: <49> (89) 9 29 30 00

Hitachi Europe Ltd.  
Electronic Components Group.  
Whitebrook Park  
Lower Cookham Road  
Maidenhead  
Berkshire SL6 8YA, United Kingdom  
Tel: <44> (1628) 585000  
Fax: <44> (1628) 778322

Hitachi Asia Pte. Ltd.  
16 Collyer Quay #20-00  
Hitachi Tower  
Singapore 049318  
Tel: 535-2100  
Fax: 535-1533

Hitachi Asia Ltd.  
Taipei Branch Office  
3F, Hung Kuo Building, No.167,  
Tun-Hwa North Road, Taipei (105)  
Tel: <886> (2) 2718-3666  
Fax: <886> (2) 2718-8180

Hitachi Asia (Hong Kong) Ltd.  
Group III (Electronic Components)  
7/F., North Tower, World Finance Centre,  
Harbour City, Canton Road, Tsim Sha Tsui,  
Kowloon, Hong Kong  
Tel: <852> (2) 735 9218  
Fax: <852> (2) 730 0281  
Telex: 40815 HITEC HX

Copyright ' Hitachi, Ltd., 1999. All rights reserved. Printed in Japan.

## HITACHI