

## OCTAL D-TYPE FLIP FLOP WITH CLEAR

- HIGH SPEED:  
 $f_{MAX} = 165 \text{ MHz (TYP.) at } V_{CC} = 5\text{V}$
- LOW POWER DISSIPATION:  
 $I_{CC} = 4 \mu\text{A (MAX.) at } T_A = 25^\circ\text{C}$
- HIGH NOISE IMMUNITY:  
 $V_{NIH} = V_{NIL} = 28\% V_{CC} \text{ (MIN.)}$
- POWER DOWN PROTECTION ON INPUTS
- SYMMETRICAL OUTPUT IMPEDANCE:  
 $|I_{OH}| = I_{OL} = 8 \text{ mA (MIN)}$
- BALANCED PROPAGATION DELAYS:  
 $t_{PLH} \cong t_{PHL}$
- OPERATING VOLTAGE RANGE:  
 $V_{CC(OPR)} = 2\text{V to } 5.5\text{V}$
- PIN AND FUNCTION COMPATIBLE WITH 74 SERIES 273
- IMPROVED LATCH-UP IMMUNITY
- LOW NOISE:  $V_{OLP} = 0.9\text{V (MAX.)}$

### DESCRIPTION

The 74VHC273 is an advanced high-speed CMOS OCTAL D-TYPE FLIP FLOP WITH CLEAR fabricated with sub-micron silicon gate and double-layer metal wiring C<sup>2</sup>MOS technology. Information signals applied to D inputs are transferred to the Q outputs on the positive going edge of the clock pulse.

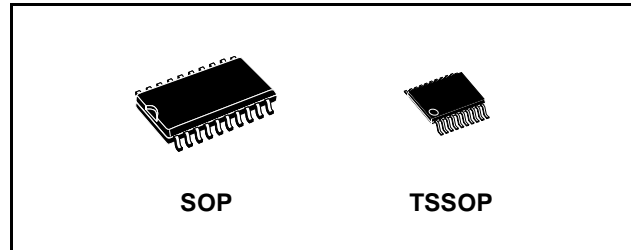

**Table 1: Order Codes**

PACKAGE	T & R
SOP	74VHC273MTR
TSSOP	74VHC273TTR

When the  $\overline{\text{CLEAR}}$  input is held low, the Q outputs are held low independently of the other inputs. Power down protection is provided on all inputs and 0 to 7V can be accepted on inputs with no regard to the supply voltage. This device can be used to interface 5V to 3V.

All inputs and outputs are equipped with protection circuits against static discharge, giving them 2KV ESD immunity and transient excess voltage.

**Figure 1: Pin Connection And IEC Logic Symbols**

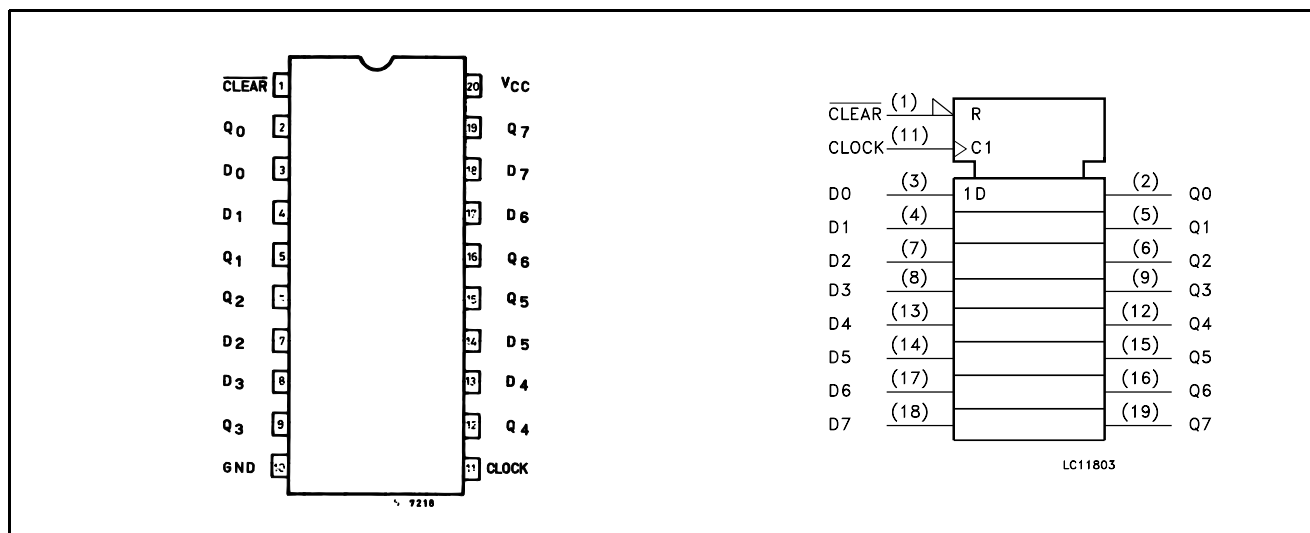

Figure 2: Input Equivalent Circuit

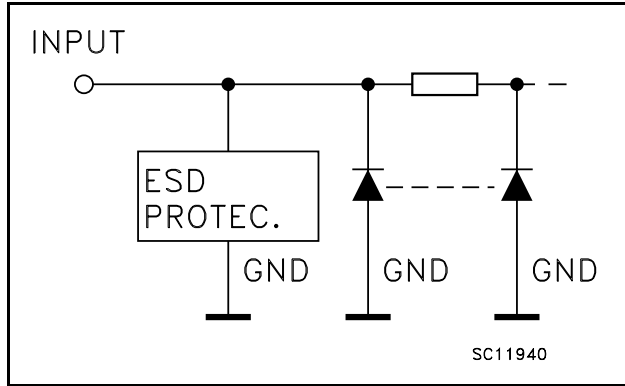

Table 2: Pin Description

PIN N°	SYMBOL	NAME AND FUNCTION
1	$\overline{\text{CLEAR}}$	Asynchronous Master Reset (Active LOW)
2, 5, 6, 9, 12, 15, 16, 19	Q0 to Q7	Flip-Flop Outputs
3, 4, 7, 8, 13, 14, 17, 18	D0 to D7	Data Inputs
11	CLOCK	Clock Input (LOW-to-HIGH Edge Triggered)
10	GND	Ground (0V)
20	V <sub>CC</sub>	Positive Supply Voltage

Table 3: Truth Table

$\overline{\text{CLEAR}}$	INPUTS		OUTPUT	FUNCTION
	D	B	Q	
L	X	X	L	CLEAR
H	L		L	
H	H		H	
H	X		Q <sub>n</sub>	NO CHANGE

X : Don't Care

Figure 3: Logic Diagram

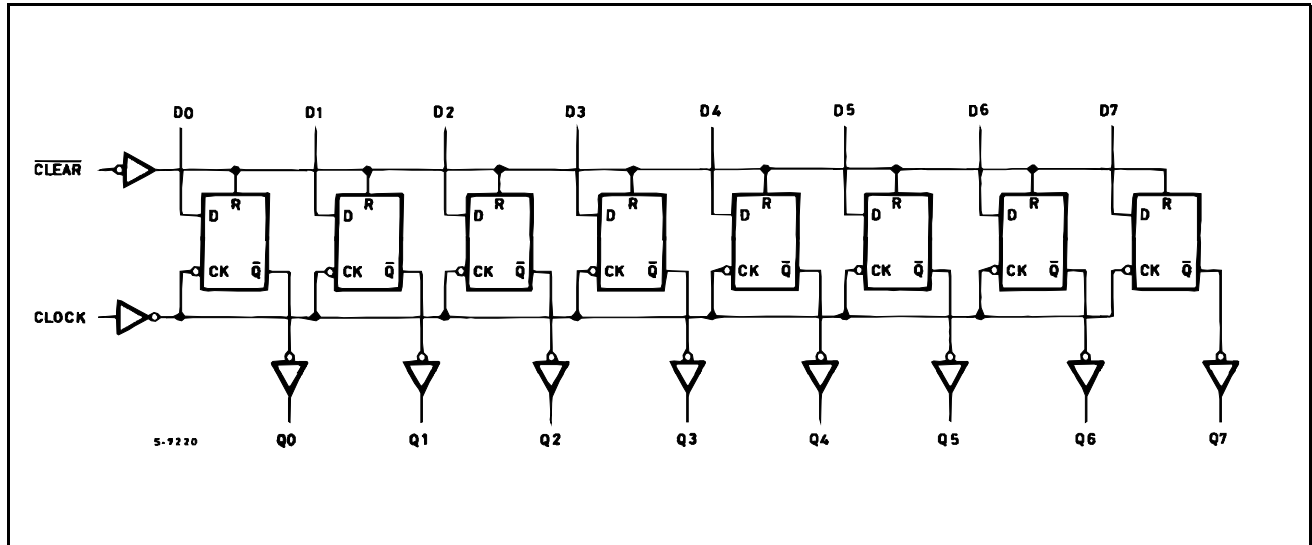

This logic diagram has not be used to estimate propagation delays

**Table 4: Absolute Maximum Ratings**

Symbol	Parameter	Value	Unit
$V_{CC}$	Supply Voltage	-0.5 to +7.0	V
$V_I$	DC Input Voltage	-0.5 to +7.0	V
$V_O$	DC Output Voltage	-0.5 to $V_{CC} + 0.5$	V
$I_{IK}$	DC Input Diode Current	- 20	mA
$I_{OK}$	DC Output Diode Current	$\pm 20$	mA
$I_O$	DC Output Current	$\pm 25$	mA
$I_{CC}$ or $I_{GND}$	DC $V_{CC}$ or Ground Current	$\pm 75$	mA
$T_{stg}$	Storage Temperature	-65 to +150	°C
$T_L$	Lead Temperature (10 sec)	300	°C

Absolute Maximum Ratings are those values beyond which damage to the device may occur. Functional operation under these conditions is not implied

**Table 5: Recommended Operating Conditions**

Symbol	Parameter	Value	Unit
$V_{CC}$	Supply Voltage	2 to 5.5	V
$V_I$	Input Voltage	0 to 5.5	V
$V_O$	Output Voltage	0 to $V_{CC}$	V
$T_{op}$	Operating Temperature	-55 to 125	°C
dt/dv	Input Rise and Fall Time (note 1) ( $V_{CC} = 3.3 \pm 0.3V$ ) ( $V_{CC} = 5.0 \pm 0.5V$ )	0 to 100 0 to 20	ns/V

1)  $V_{IN}$  from 30% to 70% of  $V_{CC}$

Table 6: DC Specifications

Symbol	Parameter	Test Condition		Value						Unit	
		V <sub>CC</sub> (V)		T <sub>A</sub> = 25°C			-40 to 85°C		-55 to 125°C		
				Min.	Typ.	Max.	Min.	Max.	Min.		Max.
V <sub>IH</sub>	High Level Input Voltage	2.0		1.5			1.5		1.5		V
		3.0 to 5.5		0.7V <sub>CC</sub>			0.7V <sub>CC</sub>		0.7V <sub>CC</sub>		
V <sub>IL</sub>	Low Level Input Voltage	2.0				0.5		0.5		0.5	V
		3.0 to 5.5				0.3V <sub>CC</sub>		0.3V <sub>CC</sub>		0.3V <sub>CC</sub>	
V <sub>OH</sub>	High Level Output Voltage	2.0	I <sub>O</sub> =-50 μA	1.9	2.0		1.9		1.9		V
		3.0	I <sub>O</sub> =-50 μA	2.9	3.0		2.9		2.9		
		4.5	I <sub>O</sub> =-50 μA	4.4	4.5		4.4		4.4		
		3.0	I <sub>O</sub> =-4 mA	2.58			2.48		2.4		
		4.5	I <sub>O</sub> =-8 mA	3.94			3.8		3.7		
V <sub>OL</sub>	Low Level Output Voltage	2.0	I <sub>O</sub> =50 μA		0.0	0.1		0.1		0.1	V
		3.0	I <sub>O</sub> =50 μA		0.0	0.1		0.1		0.1	
		4.5	I <sub>O</sub> =50 μA		0.0	0.1		0.1		0.1	
		3.0	I <sub>O</sub> =4 mA			0.36		0.44		0.55	
		4.5	I <sub>O</sub> =8 mA			0.36		0.44		0.55	
I <sub>I</sub>	Input Leakage Current	0 to 5.5	V <sub>I</sub> = 5.5V or GND			± 0.1		± 1		± 1	μA
I <sub>CC</sub>	Quiescent Supply Current	5.5	V <sub>I</sub> = V <sub>CC</sub> or GND			4		40		40	μA

Table 7: AC Electrical Characteristics (Input  $t_r = t_f = 3\text{ns}$ )

Symbol	Parameter	Test Condition		Value								Unit
		$V_{CC}$ (V)	$C_L$ (pF)	$T_A = 25^\circ\text{C}$			$-40$ to $85^\circ\text{C}$		$-55$ to $125^\circ\text{C}$			
				Min.	Typ.	Max.	Min.	Max.	Min.	Max.		
$t_{PLH}$ $t_{PHL}$	Propagation Delay Time CLOCK to Q	3.3(*)	15		8.7	13.6	1.0	16.0	1.0	16.0	ns	
		3.3(*)	50		11.2	17.1	1.0	19.5	1.0	19.5		
		5.0(**)	15		5.8	9.0	1.0	10.5	1.0	10.5		
		5.0(**)	50		7.3	11.0	1.0	12.5	1.0	12.5		
$t_{PHL}$	Propagation Delay Time CLEAR to Q	3.3(*)	15		8.9	13.6	1.0	16.0	1.0	16.0	ns	
		3.3(*)	50		11.4	17.1	1.0	19.5	1.0	19.5		
		5.0(**)	15		5.2	8.5	1.0	10.0	1.0	10.0		
		5.0(**)	50		6.7	10.5	1.0	12.0	1.0	12.0		
$t_W$	CLEAR Pulse Width LOW	3.3(*)				5.0		6.0		6.0	ns	
		5.0(**)				5.0		5.0		5.0		
$t_W$	CLOCK Pulse Width HIGH or LOW	3.3(*)				5.5		6.5		6.5	ns	
		5.0(**)				5.0		5.0		5.0		
$t_s$	Setup Time D to CLOCK, HIGH or LOW	3.3(*)				5.5		6.5		6.5	ns	
		5.0(**)				4.5		4.5		4.5		
$t_h$	Hold Time D to CLOCK, HIGH or LOW	3.3(*)				1.0		1.0		1.0	ns	
		5.0(**)				1.0		1.0		1.0		
$t_{REM}$	Removal Time CLEAR to CLOCK	3.3(*)				2.5		2.5		2.5	ns	
		5.0(**)				2.0		2.0		2.0		
$f_{MAX}$	Maximum Clock Frequency	3.3(*)	15		75	120		65		65	MHz	
		3.3(*)	50		50	75		45		45		
		5.0(**)	15		120	165		100		100		
		5.0(**)	50		80	110		70		70		
$t_{OSLH}$ $t_{OSHL}$	Output to Output Skew time (note 1)	3.3(*)	50				1.5		1.5		ns	
		5.0(**)	50				1.0		1.0			

(\*) Voltage range is  $3.3\text{V} \pm 0.3\text{V}$ (\*\*) Voltage range is  $5.0\text{V} \pm 0.5\text{V}$ Note 1: Parameter guaranteed by design.  $t_{soLH} = |t_{pLHm} - t_{pLHn}|$ ;  $t_{soHL} = |t_{pHLm} - t_{pHLn}|$ 

Table 8: Capacitive Characteristics

Symbol	Parameter	Test Condition		Value								Unit
		$T_A = 25^\circ\text{C}$			$-40$ to $85^\circ\text{C}$		$-55$ to $125^\circ\text{C}$					
		Min.	Typ.	Max.	Min.	Max.	Min.	Max.				
$C_{IN}$	Input Capacitance		7	10			10			10	pF	
$C_{PD}$	Power Dissipation Capacitance (note 1)		31								pF	

1)  $C_{PD}$  is defined as the value of the IC's internal equivalent capacitance which is calculated from the operating current consumption without load. (Refer to Test Circuit). Average operating current can be obtained by the following equation.  $I_{CC(opr)} = C_{PD} \times V_{CC} \times f_{IN} + I_{CC}/8$  (per Flip-Flop)

Table 9: Dynamic Switching Characteristics

Symbol	Parameter	Test Condition		Value						Unit	
		V <sub>CC</sub> (V)		T <sub>A</sub> = 25°C			-40 to 85°C		-55 to 125°C		
				Min.	Typ.	Max.	Min.	Max.	Min.		Max.
V <sub>OLP</sub>	Dynamic Low Voltage Quiet Output (note 1, 2)	5.0	C <sub>L</sub> = 50 pF		0.6	0.9					V
V <sub>OLV</sub>				-0.9	-0.6						
V <sub>IHD</sub>	Dynamic High Voltage Input (note 1, 3)	5.0		3.5							V
V <sub>ILD</sub>	Dynamic Low Voltage Input (note 1, 3)	5.0				1.5					V

- 1) Worst case package.
- 2) Max number of outputs defined as (n). Data inputs are driven 0V to 5.0V, (n-1) outputs switching and one output at GND.
- 3) Max number of data inputs (n) switching. (n-1) switching 0V to 5.0V. Inputs under test switching: 5.0V to threshold (V<sub>ILD</sub>), 0V to threshold (V<sub>IHD</sub>), f=1MHz.

Figure 4: Test Circuit

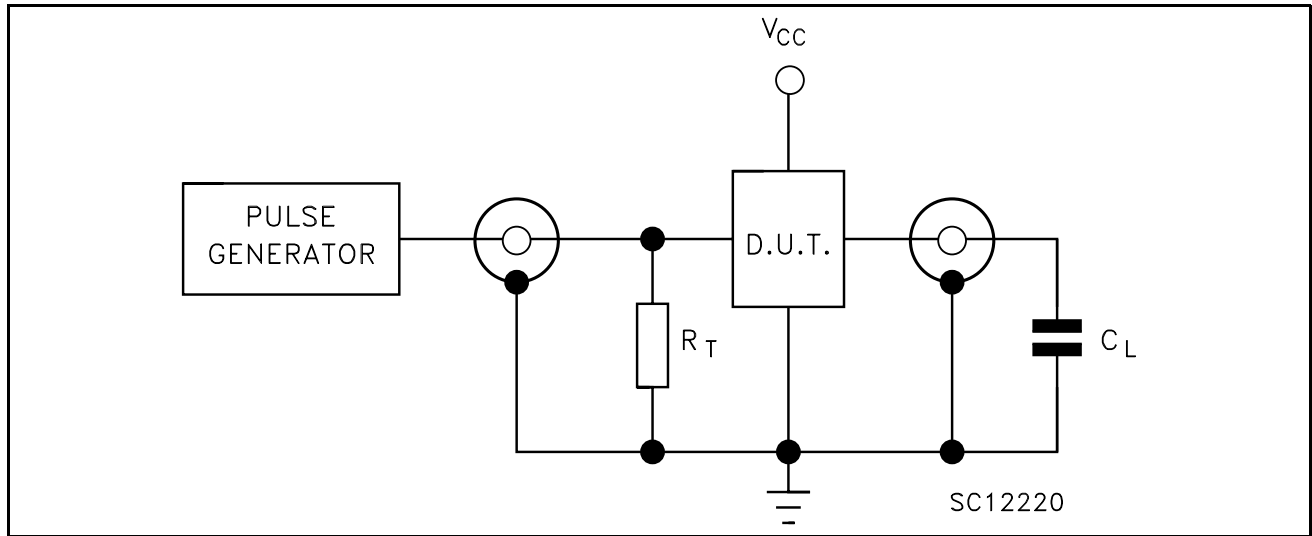

$C_L = 15/50\text{pF}$  or equivalent (includes jig and probe capacitance)  
 $R_T = Z_{OUT}$  of pulse generator (typically  $50\Omega$ )

Figure 5: Waveform - Propagation Delays, Setup And Hold Times ( $f=1\text{MHz}$ ; 50% duty cycle)

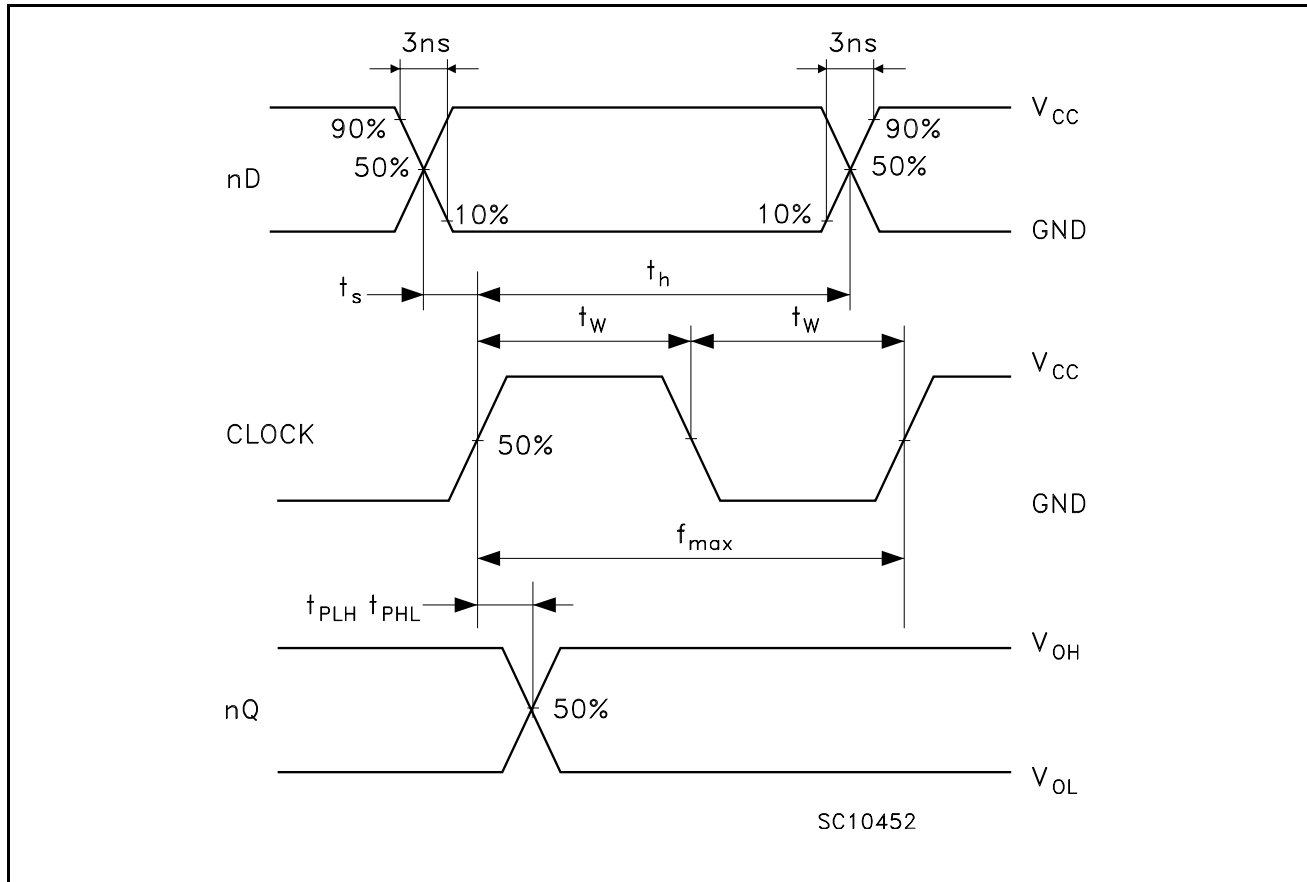

Figure 6: Waveform - Propagation Delays ( $f=1\text{MHz}$ ; 50% duty cycle)

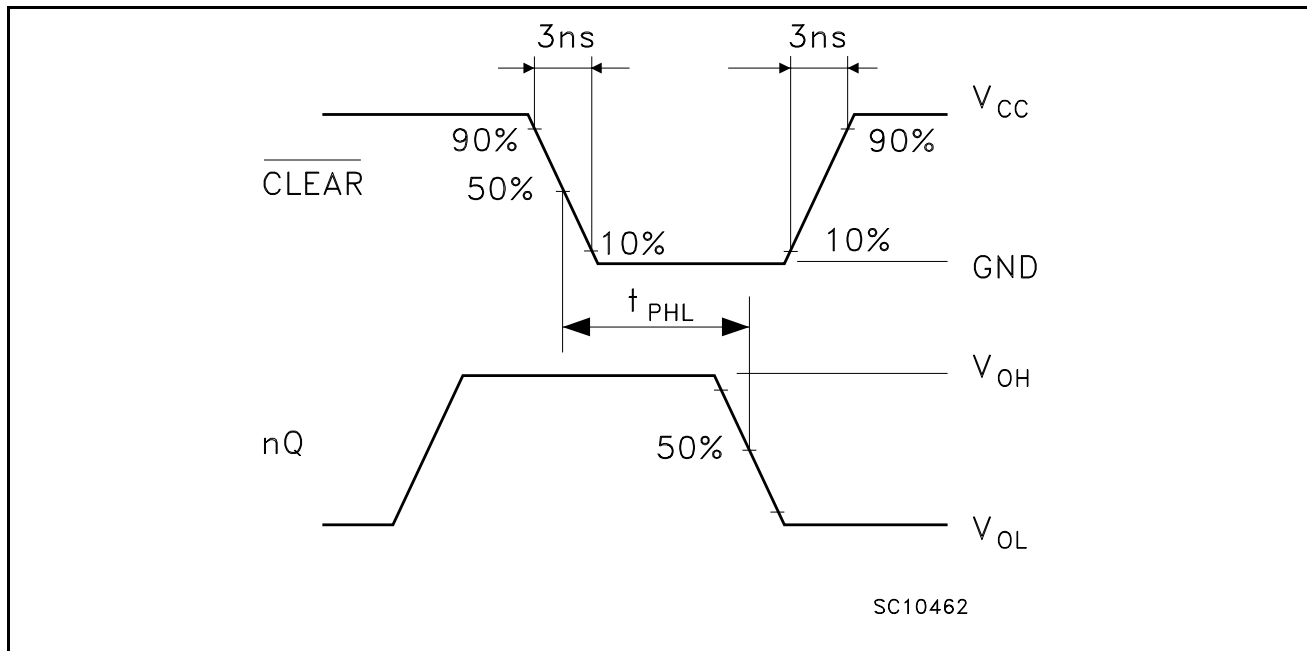
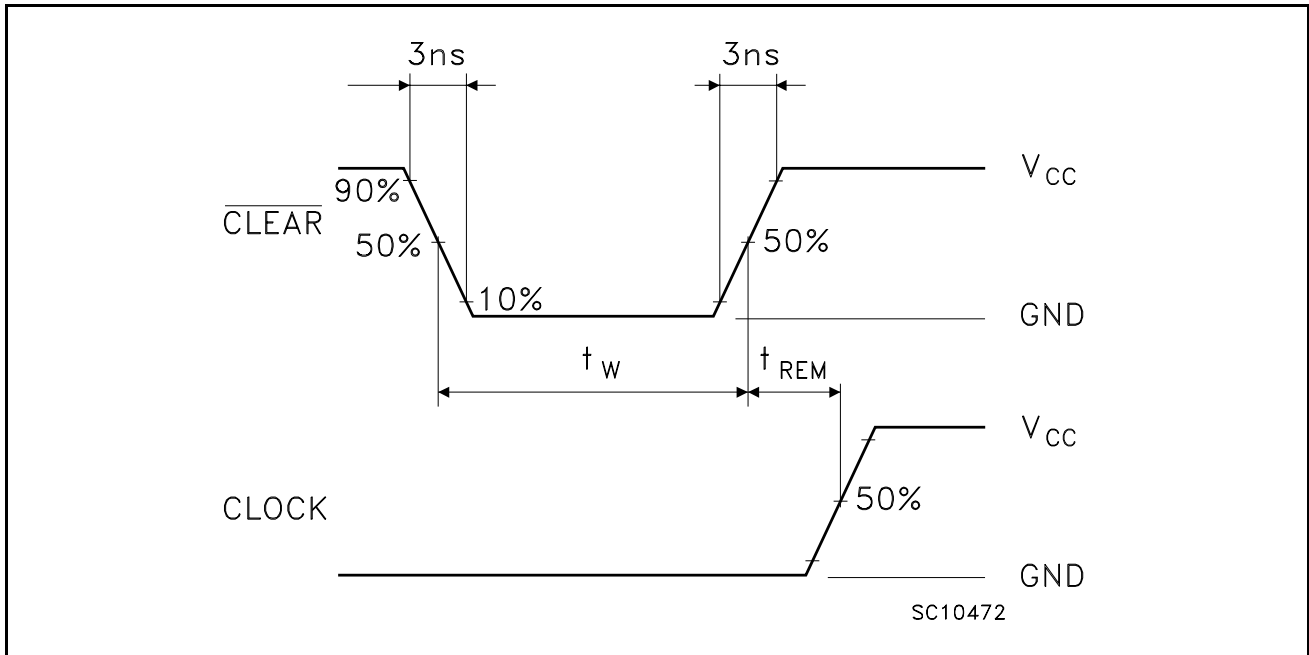

Figure 7: Waveform - Recovery Time (f=1MHz; 50% duty cycle)





## SO-20 MECHANICAL DATA

DIM.	mm.			inch		
	MIN.	TYP	MAX.	MIN.	TYP.	MAX.
A	2.35		2.65	0.093		0.104
A1	0.1		0.30	0.004		0.012
B	0.33		0.51	0.013		0.020
C	0.23		0.32	0.009		0.013
D	12.60		13.00	0.496		0.512
E	7.4		7.6	0.291		0.299
e		1.27			0.050	
H	10.00		10.65	0.394		0.419
h	0.25		0.75	0.010		0.030
L	0.4		1.27	0.016		0.050
k	0°		8°	0°		8°
ddd			0.100			0.004

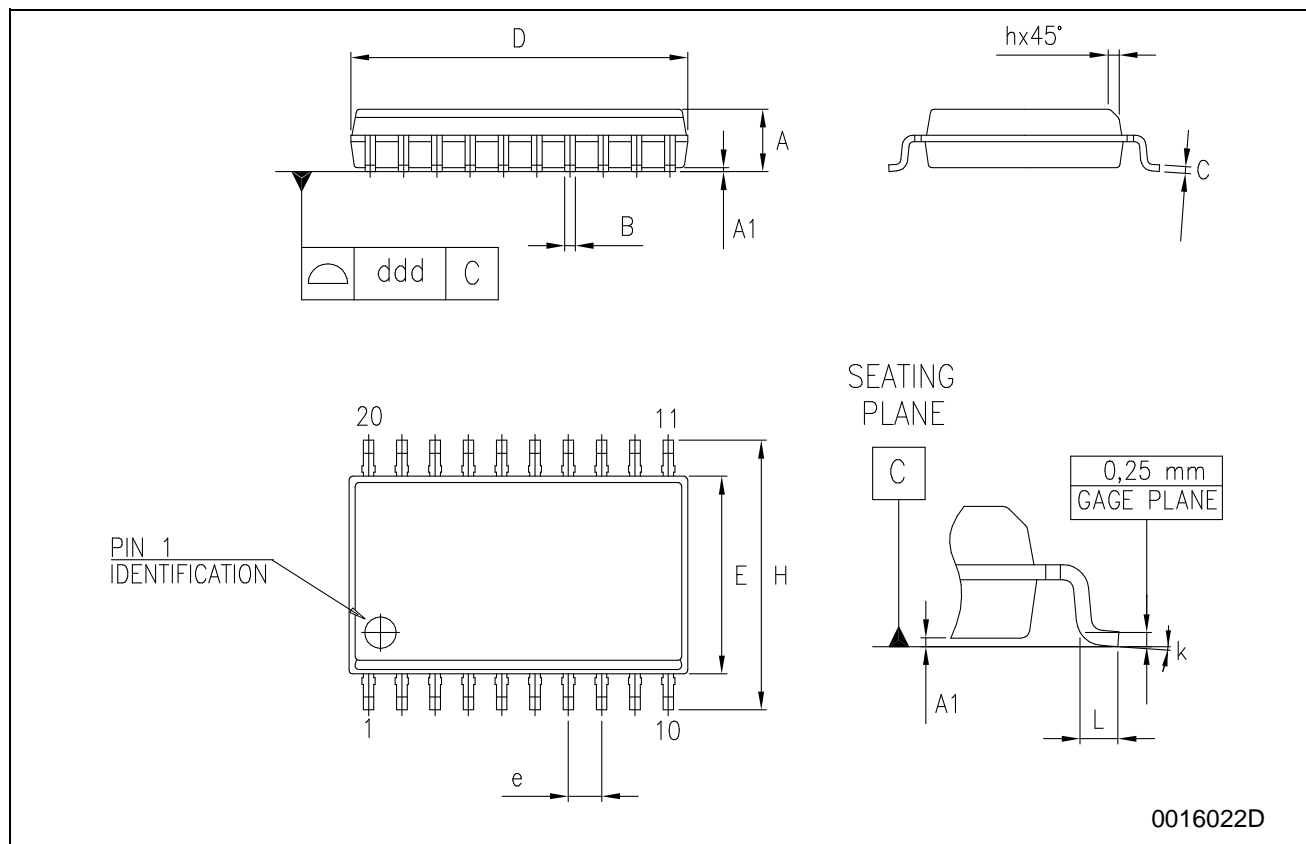

## TSSOP20 MECHANICAL DATA

DIM.	mm.			inch		
	MIN.	TYP	MAX.	MIN.	TYP.	MAX.
A			1.2			0.047
A1	0.05		0.15	0.002	0.004	0.006
A2	0.8	1	1.05	0.031	0.039	0.041
b	0.19		0.30	0.007		0.012
c	0.09		0.20	0.004		0.0079
D	6.4	6.5	6.6	0.252	0.256	0.260
E	6.2	6.4	6.6	0.244	0.252	0.260
E1	4.3	4.4	4.48	0.169	0.173	0.176
e		0.65 BSC			0.0256 BSC	
K	0°		8°	0°		8°
L	0.45	0.60	0.75	0.018	0.024	0.030

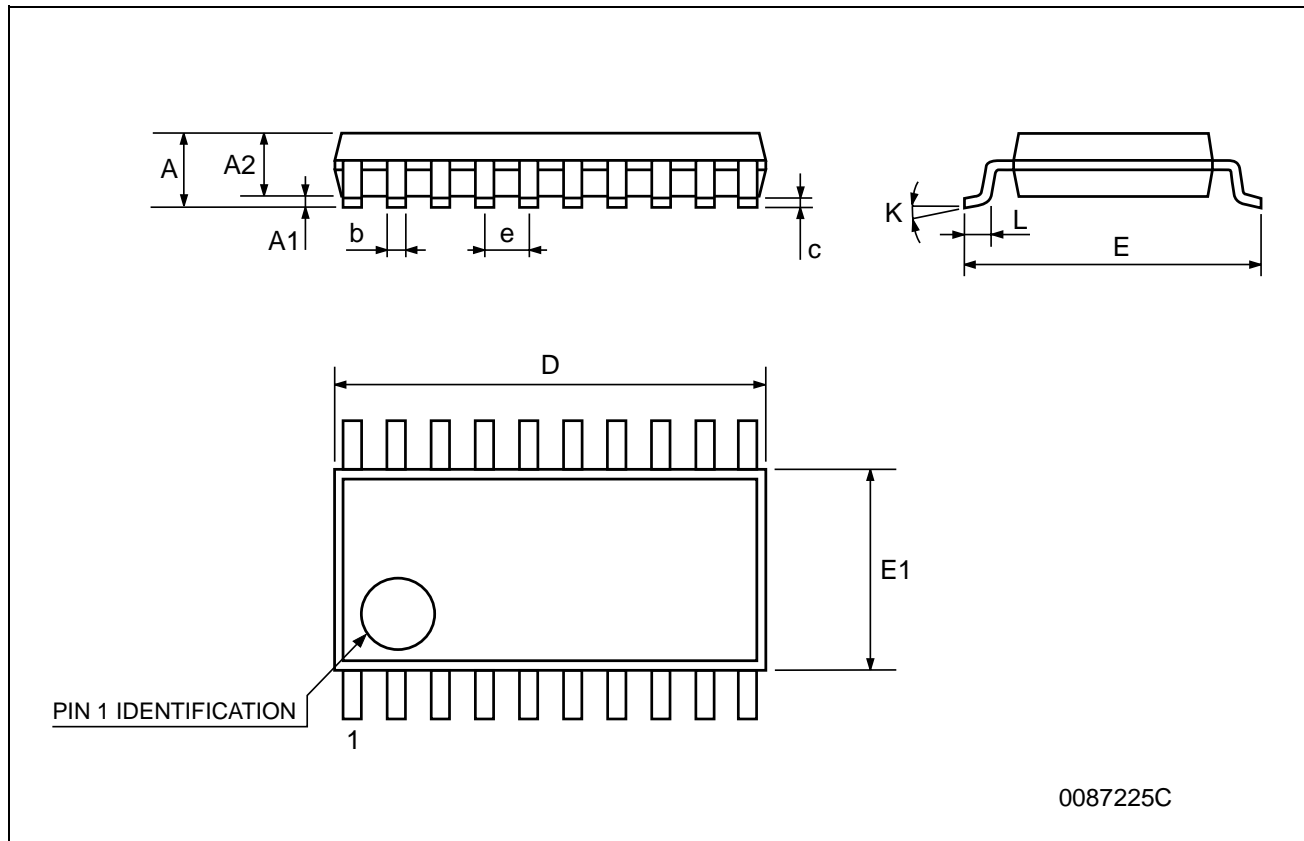

### Tape & Reel SO-20 MECHANICAL DATA

DIM.	mm.			inch		
	MIN.	TYP.	MAX.	MIN.	TYP.	MAX.
A			330			12.992
C	12.8		13.2	0.504		0.519
D	20.2			0.795		
N	60			2.362		
T			30.4			1.197
Ao	10.8		11	0.425		0.433
Bo	13.2		13.4	0.520		0.528
Ko	3.1		3.3	0.122		0.130
Po	3.9		4.1	0.153		0.161
P	11.9		12.1	0.468		0.476

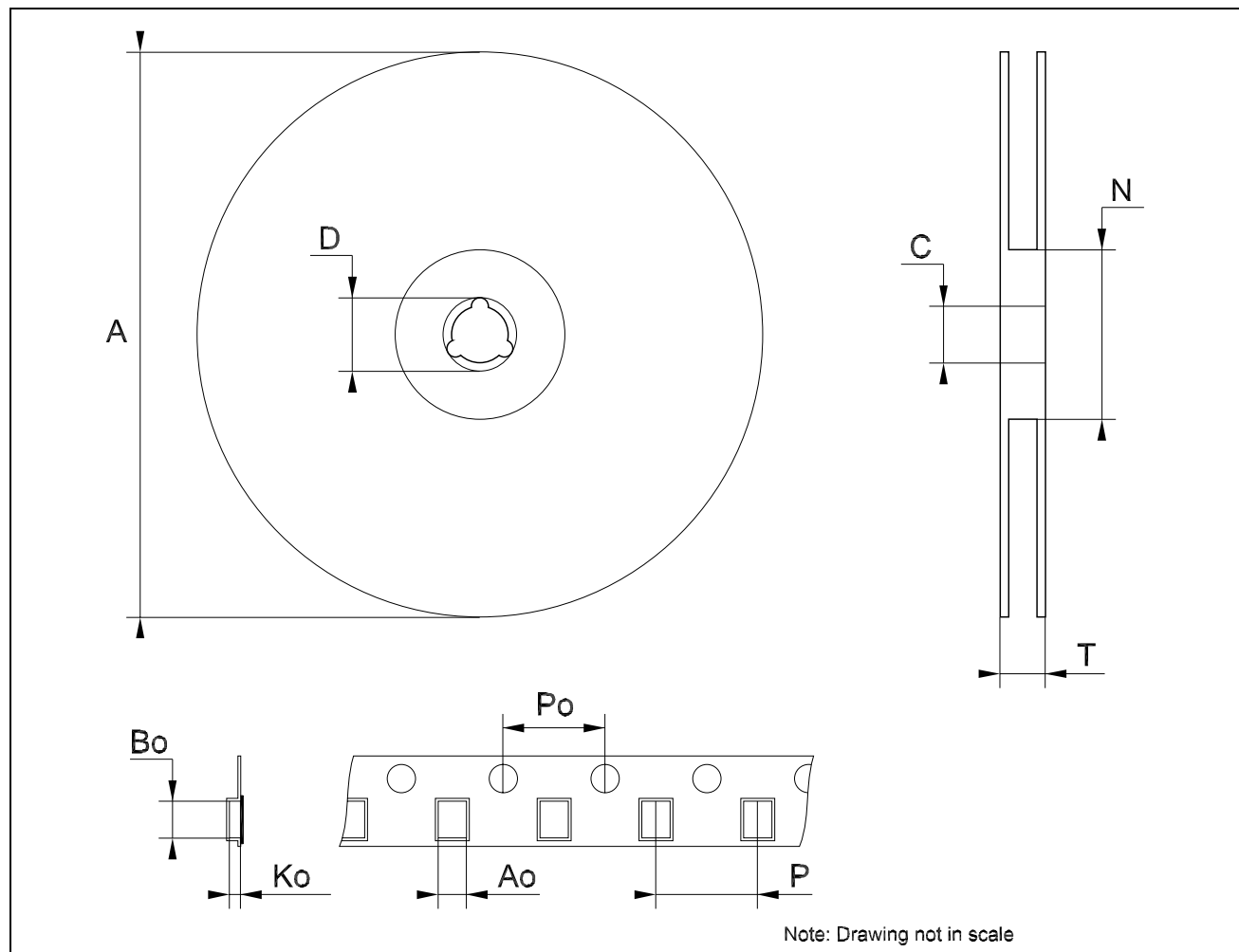

## Tape &amp; Reel TSSOP20 MECHANICAL DATA

DIM.	mm.			inch		
	MIN.	TYP.	MAX.	MIN.	TYP.	MAX.
A			330			12.992
C	12.8		13.2	0.504		0.519
D	20.2			0.795		
N	60			2.362		
T			22.4			0.882
Ao	6.8		7	0.268		0.276
Bo	6.9		7.1	0.272		0.280
Ko	1.7		1.9	0.067		0.075
Po	3.9		4.1	0.153		0.161
P	11.9		12.1	0.468		0.476

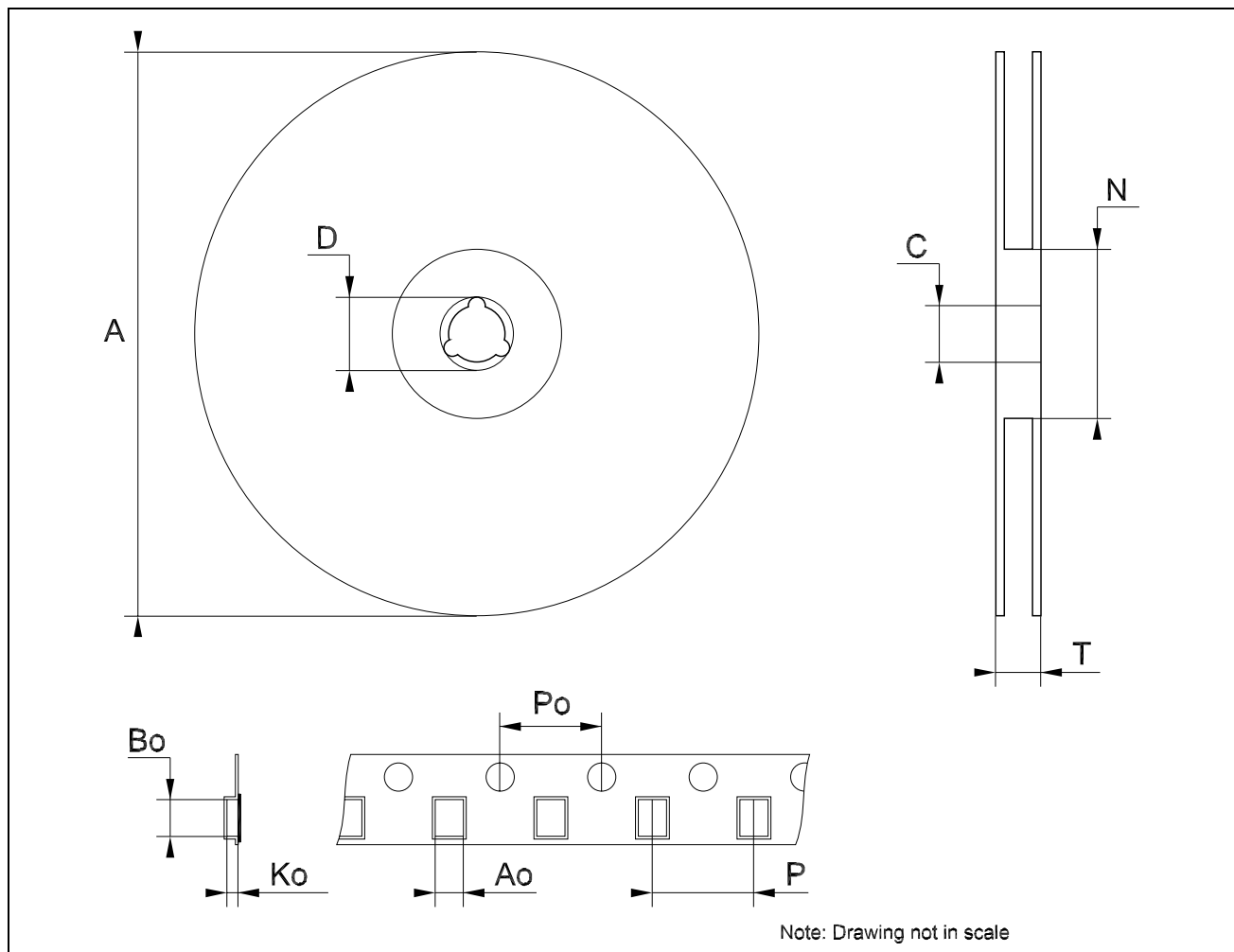

**Table 10: Revision History**

Date	Revision	Description of Changes
12-Nov-2004	5	Order Codes Revision - pag. 1.

Information furnished is believed to be accurate and reliable. However, STMicroelectronics assumes no responsibility for the consequences of use of such information nor for any infringement of patents or other rights of third parties which may result from its use. No license is granted by implication or otherwise under any patent or patent rights of STMicroelectronics. Specifications mentioned in this publication are subject to change without notice. This publication supersedes and replaces all information previously supplied. STMicroelectronics products are not authorized for use as critical components in life support devices or systems without express written approval of STMicroelectronics.

The ST logo is a registered trademark of STMicroelectronics

All other names are the property of their respective owners

© 2004 STMicroelectronics - All Rights Reserved

STMicroelectronics group of companies

Australia - Belgium - Brazil - Canada - China - Czech Republic - Finland - France - Germany - Hong Kong - India - Israel - Italy - Japan -  
Malaysia - Malta - Morocco - Singapore - Spain - Sweden - Switzerland - United Kingdom - United States of America

[www.st.com](http://www.st.com)