



1.3 GHz Prescaler

The MC12066 is a selectable divide by 64/256 prescaler. Typical frequency synthesis applications include electronically tuned TV/CATV and communication systems as well as instrumentation.

The MC12066 is pin and functionally compatible to the Plessey SP4666, but with significantly lower power consumption.

An internal, two stage preamplifier is included which isolates the differential inputs and provides gain for the input signal. Differential outputs are provided.

The MC12066 contains an internal low pass filter to reduce harmonic content to a low level. The filter bandwidth is selectable depending on the state of the SEL pin. The typical -3.0 dB bandwidth is 4.3 MHz for $\div 256$ mode, and 17.2 MHz for $\div 64$ mode. Figures 2 and 3 illustrate typical device performance.

- 1.3 GHz Toggle Frequency
- Operating Supply Voltage of 2.7 to 5.5 V
- Low-Power 7.5 mA Typical at $V_{CC} = 5.0$ V
- High Input Sensitivity, 5 mVrms Max at $V_{CC} = 2.7$ to 5.5, $T_A = -40$ to 85°C
- 600 mV Minimum Peak-to-Peak Output Swing
- Differential Outputs

TRUTH TABLE

SEL	Prescaler
L	256
H	64

MAXIMUM RATINGS

Characteristic	Symbol	Range	Unit
Power Supply Voltage	V_{CC}	7.0	Vdc
Operating Temperature Range	T_A	-40 to 85	$^\circ\text{C}$
Storage Temperature Range	T_{stg}	-65 to 175	$^\circ\text{C}$

NOTE: ESD data available upon request.

ELECTRICAL CHARACTERISTICS ($V_{CC} = 2.7$ to 5.5 V;

$T_A = -40$ to 85°C , unless otherwise noted.)

Characteristic	Symbol	Min	Typ ¹	Max	Unit
Toggle Frequency (Sine Wave Input)	f_{max}^2 f_{min}	1.3 –	1.6 –	– 50	GHz MHz
Supply Current at 5.5 V	I_{CC}	–	7.5	12	mA
Output Voltage (Load = 12 pF)	V_{out}	0.6	1.0	–	V_{pp}
Input Voltage Sensitivity 50–200 MHz 200–1300 MHz	$V_{in min}$	– –	2.5 0.5	10 5	mVrms
Input Overload	$V_{in max}$	200	400	–	mVrms
Input HIGH Voltage (SEL)	V_{IH}	$0.7V_{CC}$	–	–	V
Input LOW Voltage (SEL)	V_{IL}	–	–	$0.3V_{CC}$	V

NOTES: 1. Typical measured at 25°C , 5.0 V
2. See Figure 2

MC12066

MECL PLL COMPONENTS $\div 64/256$ PRESCALER

SEMICONDUCTOR TECHNICAL DATA



D SUFFIX
PLASTIC PACKAGE
CASE 751
(SO–8)

PIN CONNECTIONS

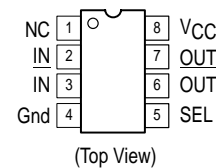

ORDERING INFORMATION

Device	Operating Temperature Range	Package
MC12066D	$T_A = -40^\circ$ to $+85^\circ\text{C}$	SO–8

MC12066

Figure 1. Prescaler Block Diagram

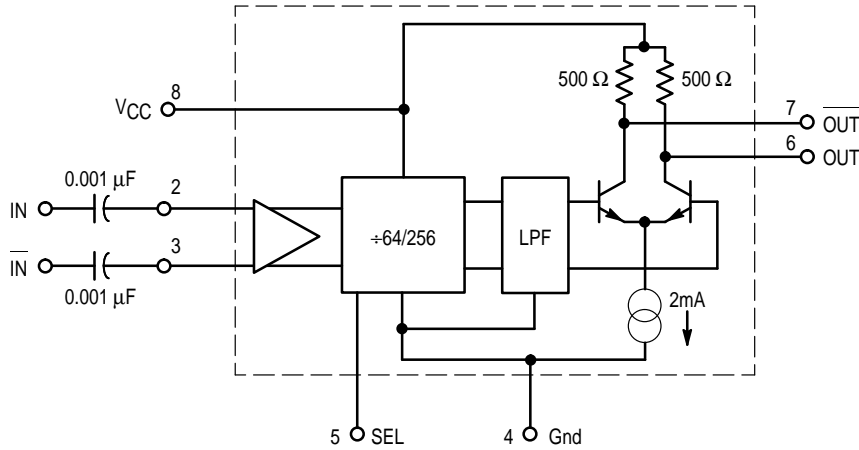
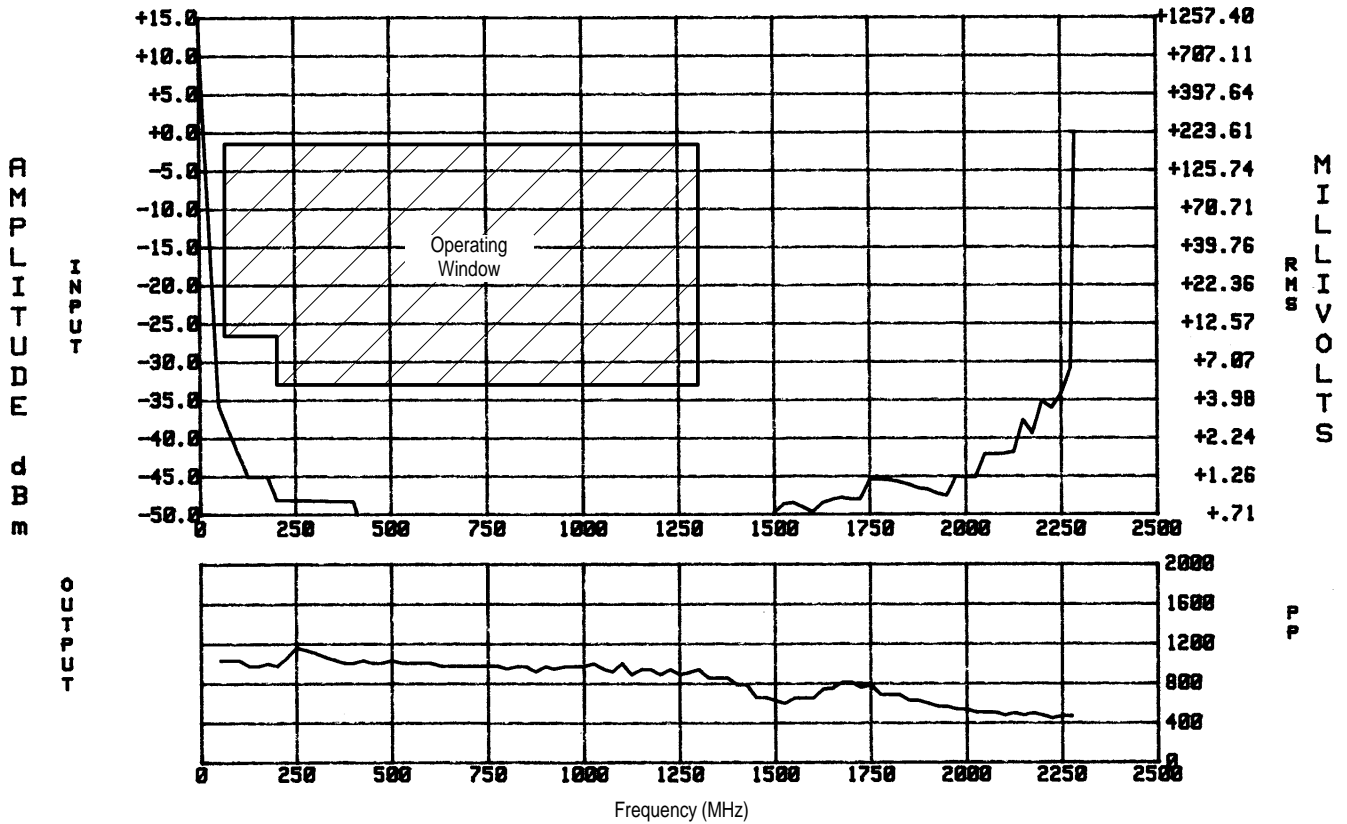

Figure 2. Typical Input Signal Amplitude and Output Peak-to-Peak Amplitude versus Input Frequency With a Divide Ratio of 64



MC12066

Figure 3. Output Spectrum Illustrating Harmonic Suppression, Input Frequency 900 MHz, ÷64 Divide Ratio

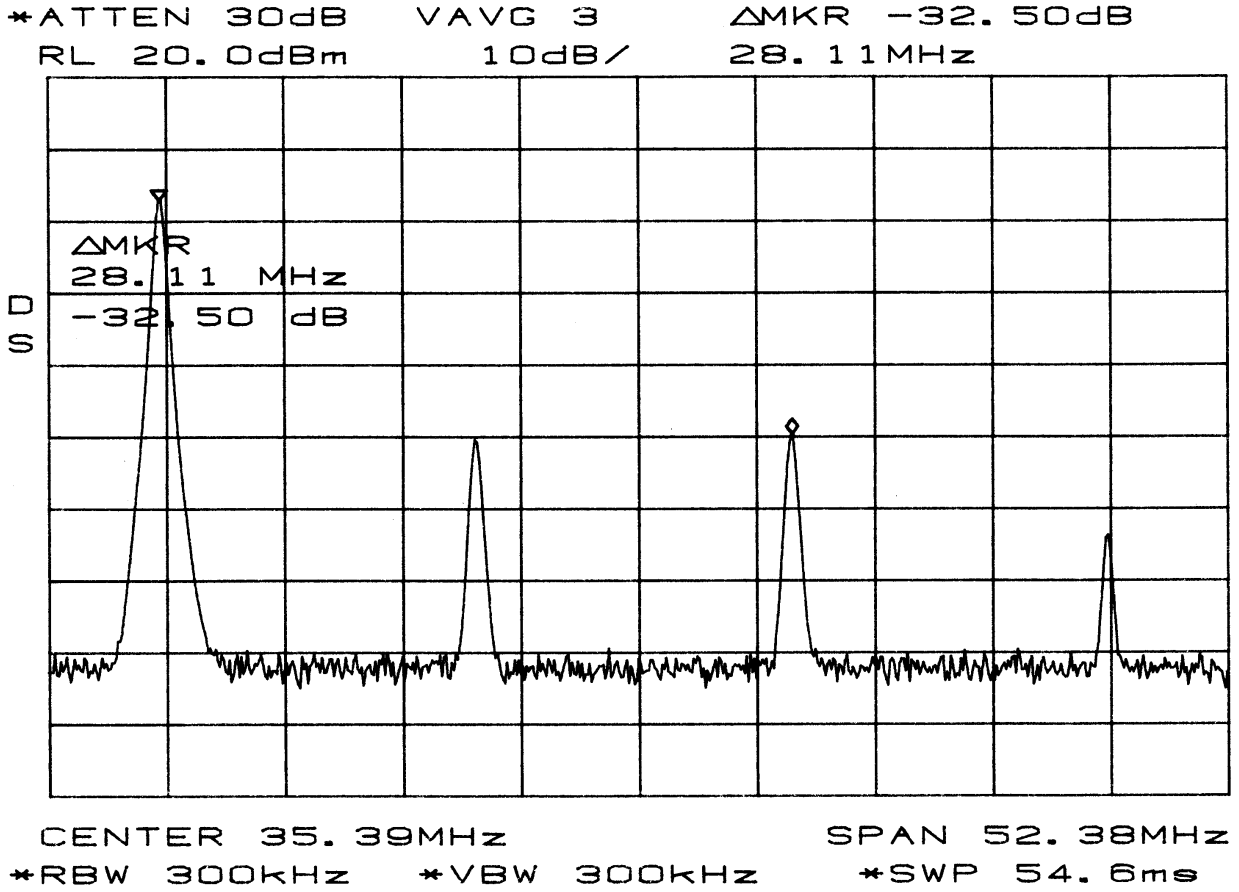
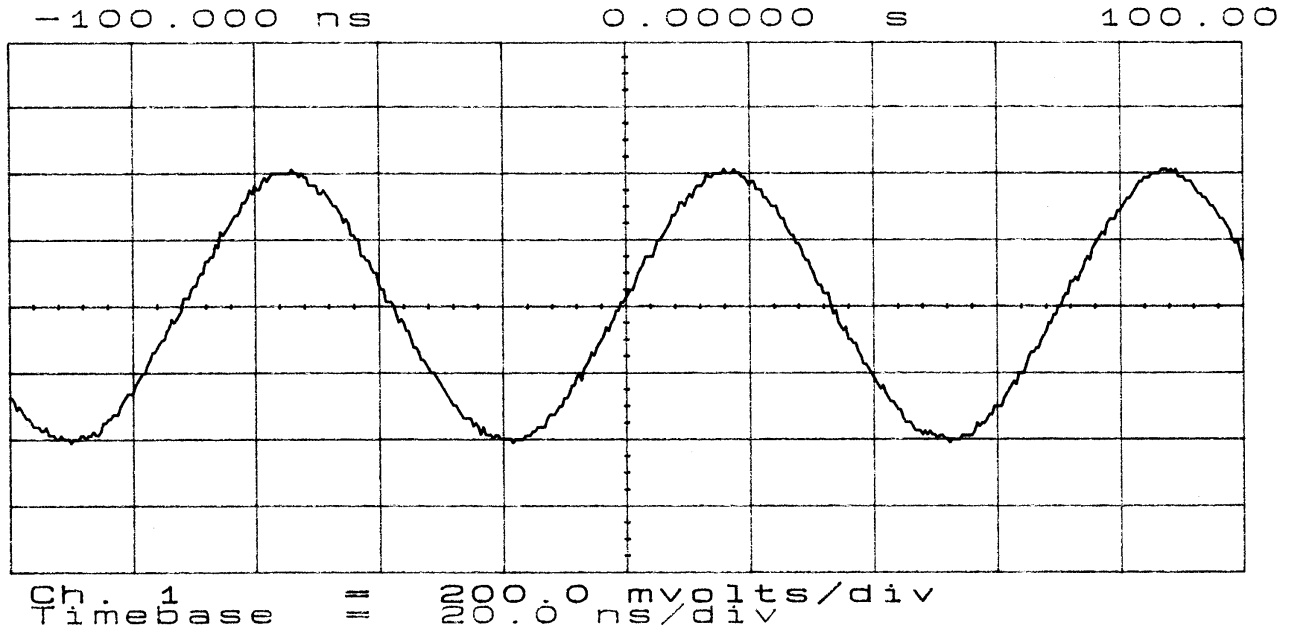

Figure 4. Typical Output Waveform, Input Frequency 900 MHz, ÷64 Divide Ratio



MC12066

OUTLINE DIMENSIONS

D SUFFIX
PLASTIC PACKAGE
CASE 751-06
(SO-8)
ISSUE T

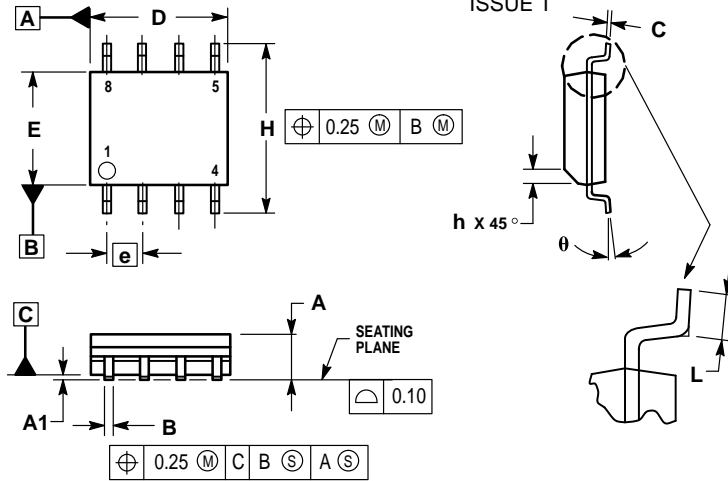

NOTES:

1. DIMENSIONING AND TOLERANCING PER ASME Y14.5M, 1994.
2. DIMENSIONS ARE IN MILLIMETER.
3. DIMENSION D AND E DO NOT INCLUDE MOLD PROTRUSION.
4. MAXIMUM MOLD PROTRUSION 0.15 PER SIDE.
5. DIMENSION B DOES NOT INCLUDE DAMBAR PROTRUSION. ALLOWABLE DAMBAR PROTRUSION SHALL BE 0.127 TOTAL IN EXCESS OF THE B DIMENSION AT MAXIMUM MATERIAL CONDITION.

DIM	MILLIMETERS	
	MIN	MAX
A	1.35	1.75
A1	0.10	0.25
B	0.35	0.49
C	0.19	0.25
D	4.80	5.00
E	3.80	4.00
e	1.27 BSC	
H	5.80	6.20
h	0.25	0.50
L	0.40	1.25
θ	0°	7°

Motorola reserves the right to make changes without further notice to any products herein. Motorola makes no warranty, representation or guarantee regarding the suitability of its products for any particular purpose, nor does Motorola assume any liability arising out of the application or use of any product or circuit, and specifically disclaims any and all liability, including without limitation consequential or incidental damages. "Typical" parameters which may be provided in Motorola data sheets and/or specifications can and do vary in different applications and actual performance may vary over time. All operating parameters, including "Typicals" must be validated for each customer application by customer's technical experts. Motorola does not convey any license under its patent rights nor the rights of others. Motorola products are not designed, intended, or authorized for use as components in systems intended for surgical implant into the body, or other applications intended to support or sustain life, or for any other application in which the failure of the Motorola product could create a situation where personal injury or death may occur. Should Buyer purchase or use Motorola products for any such unintended or unauthorized application, Buyer shall indemnify and hold Motorola and its officers, employees, subsidiaries, affiliates, and distributors harmless against all claims, costs, damages, and expenses, and reasonable attorney fees arising out of, directly or indirectly, any claim of personal injury or death associated with such unintended or unauthorized use, even if such claim alleges that Motorola was negligent regarding the design or manufacture of the part. Motorola and are registered trademarks of Motorola, Inc. Motorola, Inc. is an Equal Opportunity/Affirmative Action Employer.

Mfax is a trademark of Motorola, Inc.

How to reach us:

USA/EUROPE/Locations Not Listed: Motorola Literature Distribution;
P.O. Box 5405, Denver, Colorado 80217. 1-303-675-2140 or 1-800-441-2447

JAPAN: Nippon Motorola Ltd.: SPD, Strategic Planning Office, 141,
4-32-1 Nishi-Gotanda, Shagawa-ku, Tokyo, Japan. 03-5487-8488

Customer Focus Center: 1-800-521-6274

Mfax™: RMFAX0@email.sps.mot.com – TOUCHTONE 1-602-244-6609
Motorola Fax Back System – US & Canada ONLY 1-800-774-1848
– http://sps.motorola.com/mfax/

ASIA/PACIFIC: Motorola Semiconductors H.K. Ltd.; 8B Tai Ping Industrial Park,
51 Ting Kok Road, Tai Po, N.T., Hong Kong. 852-26629298

HOME PAGE: <http://motorola.com/sps/>



MC12066/D