

MC14C89B

Quad Low Power Line Receivers

The MC14C89B and MC14C89AB are low monolithic quad line receivers using bipolar technology, which conform to the EIA-232-E, EIA-562 and CCITT V.28 Recommendations. The outputs feature LSTTL and CMOS compatibility for easy interface to +5.0 V digital systems. Internal time-domain filtering eliminates the need for external filter capacitors in most cases.

The MC14C89B has an input hysteresis of 0.35 V, while the MC14C89AB hysteresis is 0.95 V. The response control pins allow adjustment of the threshold level if desired. Additionally, an external capacitor may be added for additional noise filtering.

The MC14C89B and MC14C89AB are available in both a 14 pin dual-in-line plastic DIP and SOIC package.

Features:

- Low Power Consumption
- Meets EIA-232-E, EIA-562, and CCITT V.28 Recommendations
- TTL/CMOS Compatible Outputs
- Standard Power Supply: + 5.0 V \pm 10%
- Pin Equivalent to MC1489, MC1489A, TI's SN75C189/A, SN75189/A and National Semiconductor's DS14C89/A
- External Filtering Not Required in Most Cases
- Threshold Level Externally Adjustable
- Hysteresis: 0.35 V for MC14C89B, 0.95 V for MC14C89AB
- Available in Plastic DIP, and Surface Mount Packaging
- Operating Ambient Temperature: -40° to +85°C

Representative Block Diagram
(Each Receiver)

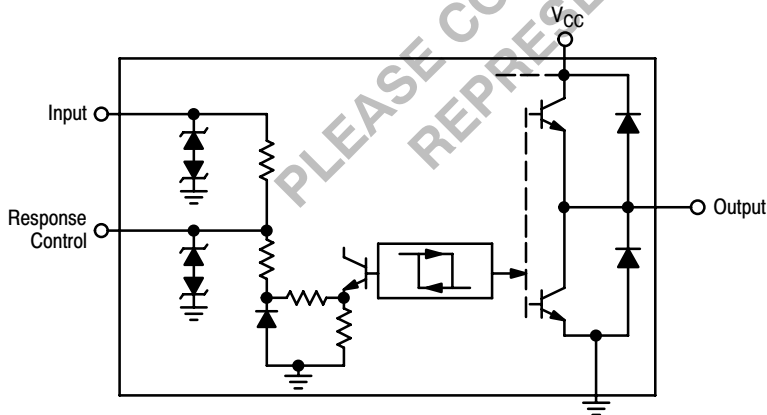

ON Semiconductor®

<http://onsemi.com>

QUAD LOW POWER LINE RECEIVERS SEMICONDUCTOR TECHNICAL DATA

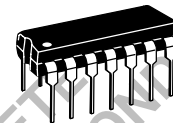

P SUFFIX
PLASTIC PACKAGE
CASE 646



D SUFFIX
PLASTIC PACKAGE
CASE 751A
(SO-14)

PIN CONNECTIONS

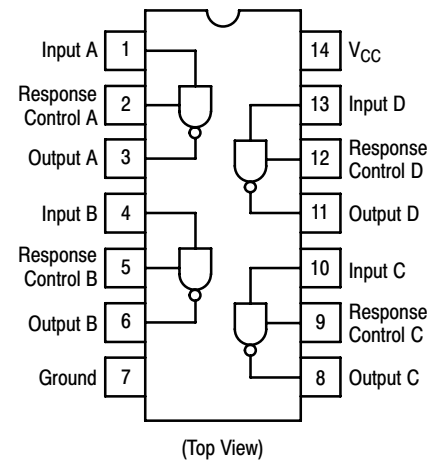

ORDERING INFORMATION

Device	Operating Temperature Range	Package
MC14C89BP	$T_A = -40^\circ \text{ to } +85^\circ \text{C}$	Plastic DIP
MC14C89ABP		Plastic DIP
MC14C89ABD		SO-14

MC14C89B

MAXIMUM RATINGS

Rating	Symbol	Value	Unit
Power Supply Voltage $V_{CC(max)}$ $V_{CC(min)}$	V_{CC}	+ 7.0 - 0.5	Vdc
Input Voltage	V_{in}	± 30	Vdc
Output Load Current	I_O	Self-Limiting	-
Junction Temperature	T_J	-65, +150	°C

Devices should not be operated at these limits. The "Recommended Operating Conditions" table provides for actual device operation.

RECOMMENDED OPERATING CONDITIONS

Characteristic	Symbol	Min	Typ	Max	Unit
Power Supply Voltage	V_{CC}	4.5	5.0	5.5	Vdc
Input Voltage	V_{in}	-25	-	25	Vdc
Output Current Capability	I_O	-7.5	-	6.0	mA
Operating Ambient Temperature	T_A	-40	-	85	°C

All limits are not necessarily functional concurrently.

ELECTRICAL CHARACTERISTICS ($-40^{\circ}\text{C} \leq T_A \leq +85^{\circ}\text{C}$, unless otherwise noted.)*

Characteristic	Symbol	Min	Typ	Max	Unit
Supply Current ($I_{out} = 0$) $I_{CC} @ +4.5\text{ V} \leq V_{CC} \leq +5.5\text{ V}$	I_{CC}	-	330	700	μA
Output Voltage - High, $V_{in} \leq 0.4\text{ V}$ (See Figures 2 and 3) $I_{out} = -20\ \mu\text{A}$ $V_{CC} = 4.5\text{ V}$ $V_{CC} = 5.5\text{ V}$ $I_{out} = -3.2\text{ mA}$ $V_{CC} = 4.5\text{ V}$ $V_{CC} = 5.5\text{ V}$	V_{OH}	3.5 3.5 2.5 2.5	3.8 4.8 3.7 4.7	- - - -	Vdc
Output Voltage - Low, $V_{in} \geq 2.4\text{ V}$ $I_{out} = 3.2\text{ mA}$ $V_{CC} = 4.5\text{ V}$ $V_{CC} = 5.5\text{ V}$	V_{OL}	- -	0.1 0.1	0.4 0.4	
Output Short Circuit Current** ($V_{CC} = 5.5\text{ V}$, see Figure 4) Normally High Output shorted to ground Normally Low Output shorted to V_{CC}	I_{OS}	-35 -	-13.9 +10.3	- 35	mA
Input Threshold Voltage ($V_{CC} = 5.0\text{ V}$) (MC14C89AB, see Figure 5) Low Level High Level (MC14C89B, see Figure 6) Low Level High Level	V_{IL} V_{IH} V_{IL} V_{IH}	0.75 1.6 0.75 1.0	0.95 1.90 0.95 1.3	1.25 2.25 1.25 1.5	Vdc
Input Impedance ($+4.5\text{ V} < V_{CC} < +5.5\text{ V} - 25\text{ V} < V_{in} < +25\text{ V}$)		3.0	5.5	7.0	$\text{k}\Omega$

* Typicals reflect performance @ $T_A = 25^{\circ}\text{C}$

**Only one output shorted at a time, for not more than 1.0 seconds.

TIMING CHARACTERISTICS ($T_A = +25^{\circ}\text{C}$, unless otherwise noted.)

Characteristic	Symbol	Min	Typ	Max	Unit
Output Transition Time (10% to 90%) $4.5\text{ V} \leq V_{CC} \leq 5.5\text{ V}$	t_T	-	0.08	0.30	μs
Propagation Delay Time $4.5\text{ V} \leq V_{CC} \leq 5.5\text{ V}$ Output Low-to-High Output High-to-Low	t_{PLH} t_{PHL}	- -	3.35 2.55	6.0 6.0	μs
Input Noise Rejection (see Figure 9)		1.0	1.5	-	μs

MC14C89B

Figure 1. Timing Diagram

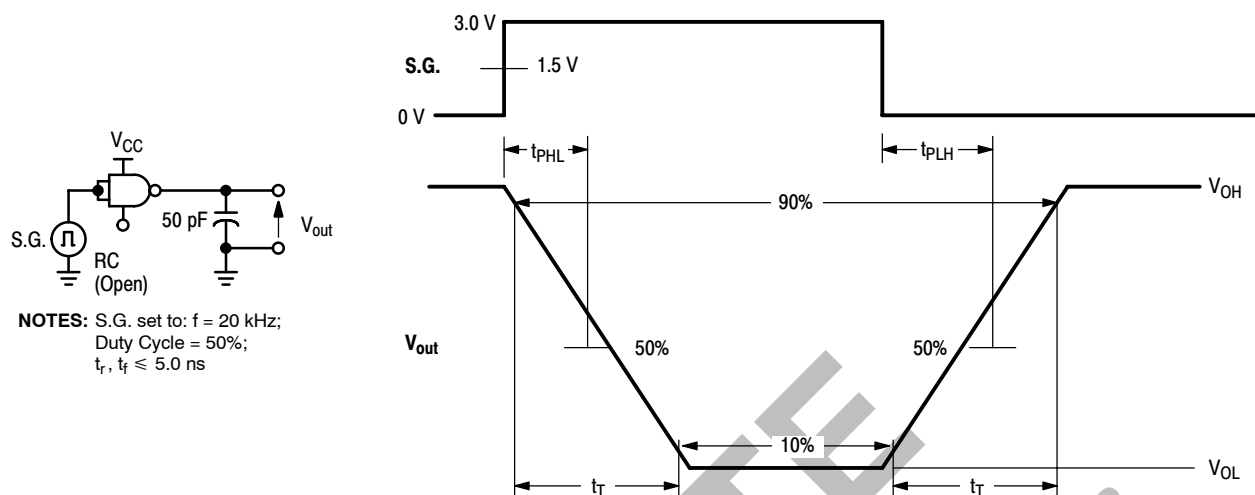

NOTES: S.G. set to: f = 20 kHz;
Duty Cycle = 50%;
t_r, t_f ≤ 5.0 ns

STANDARDS COMPLIANCE

The MC14C89B and MC14C89AB are designed to comply with EIA-232-E (formerly RS-232), the newer EIA-562 (which is a higher speed version of the EIA-232), and CCITT V.28 Recommendations. EIA-562 was written around modern integrated circuit technology, whereas EIA-232 retains many of the specifications written around the electro-mechanical circuitry in use at the time of its creation. Yet the user will find enough similarities to allow a certain amount of compatibility among equipment built to the two standards. Following is a summary of the key specifications relating to the systems and the receivers.

Parameter	EIA-232-E	EIA-562
Max Data Rate	20 kBaud	38.4 kBaud Asynchronous 64 kBaud Synchronous
Max Cable Length	50 feet	Based on cable capacitance/data rate
Transition Region	-3.0 V to +3.0 V	-3.0 V to +3.0 V
MARK (one, off)	More negative than -3.0 V	More negative than -3.3 V
SPACE (zero, on)	More positive than +3.0 V	More positive than +3.3 V
Fail Safe	Output = Binary 1	Output = Binary 1
Open Circuit Input Voltage	≤ 2.0 V	Not Specified
Slew Rate (at the driver)	≤ 30 V/μs anywhere on the waveform	≤ 30 V/μs anywhere on the waveform, ≥ 4.0 V/μs between +3.0 V and -3.0 V
Loaded Output Voltage (at the driver)	5.0 V ≤ V _O ≤ 15 V for loads between 3.0 kΩ and 7.0 kΩ	V _O ≥ 3.7 V for a load of 3.0 kΩ

MC14C89B

Figure 2. Typical Output versus Supply Voltage

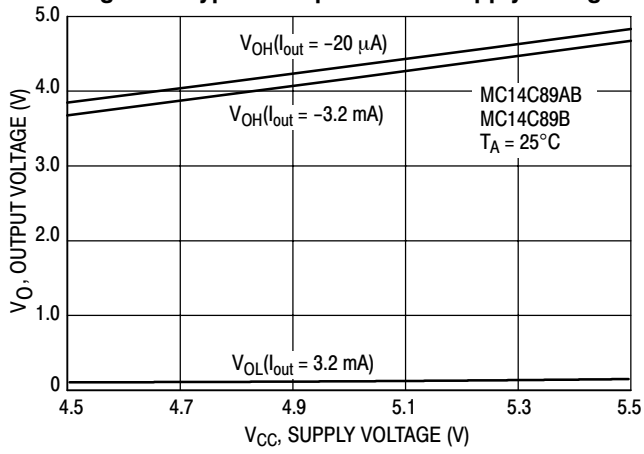
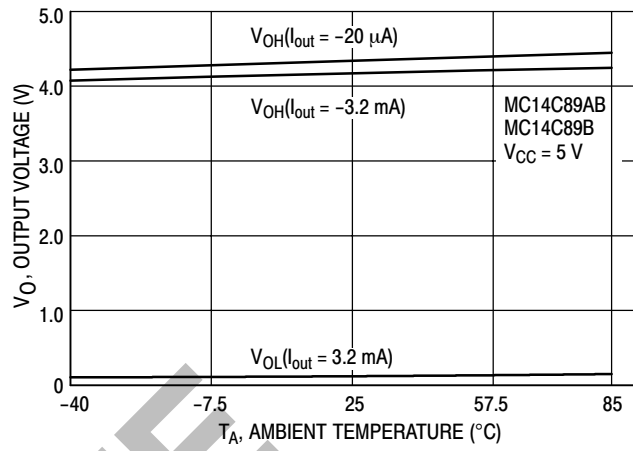

Figure 3. Typical Output Voltage versus Temperature



OBSOLETE
THIS DEVICE IS OBSOLETE
PLEASE CONTACT YOUR ON SEMICONDUCTOR
REPRESENTATIVE FOR INFORMATION

MC14C89B

Figure 4. Typical Short Circuit Current versus Temperature

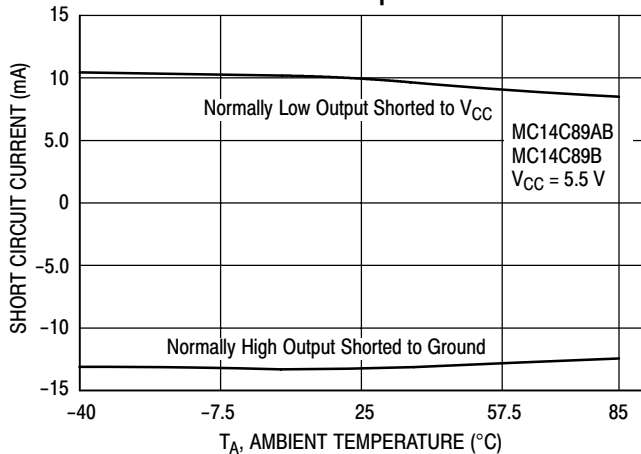

Figure 5. Typical Threshold Voltage versus Temperature

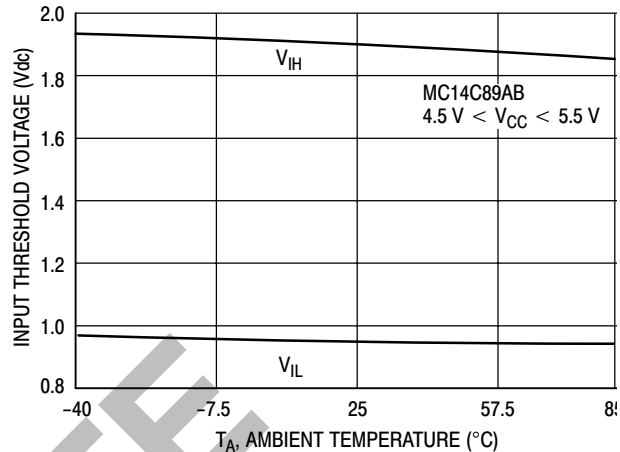

Figure 6. Typical Threshold Voltage versus Temperature

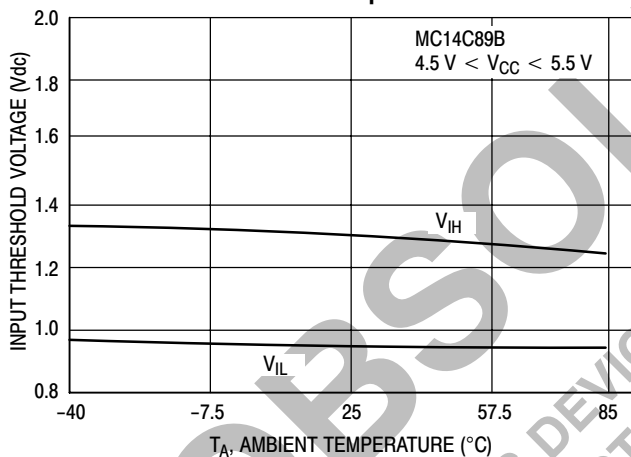

Figure 7. Typical Effect of Response Control Pin Bias

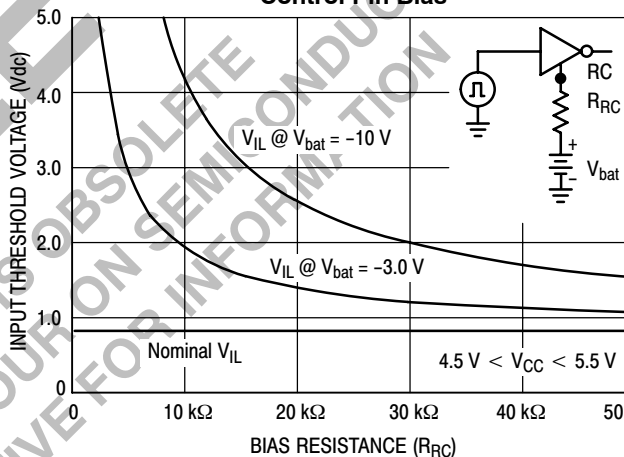
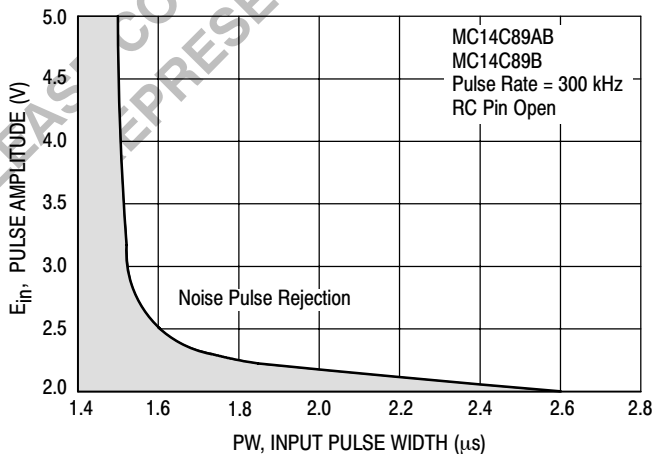

Figure 8. Typical Noise Pulse Rejection



APPLICATIONS INFORMATION

Description

The MC14C89AB and MC14C89B are designed to be direct replacements for the MC1489A and MC1489. Both devices meet all EIA-232 specifications and also the faster EIA-562 and CCITT V.28 specifications. Noise pulse rejection circuitry eliminates the need for most response control filter capacitors but does not exclude the possibility as filtering is still possible at the Response Control (RC) pins. Also, the Response Control pins allow for a user defined selection of the threshold voltages. The MC14C89AB and MC14C89B are manufactured with a bipolar technology using low power techniques and consume at most 700 μA , plus load currents with a +5.0 V supply.

Outputs

The output low or high voltage depends on the state of the inputs, the load current, the bias of the Response Control pins, and the supply voltage. Table 1 applies to each receiver, regardless of how many other receivers within the package are supplying load current.

Table 1. Function Table
Receivers

Input*	Output*
H	L
L	H

*The asterisk denotes A, B, C, or D.

Receiver Inputs and Response Control

The receiver inputs determine the state of the outputs in accordance with Table 1. The nominal V_{IL} and V_{IH} thresholds are 0.95 V and 1.90 V respectively for the MC14C89AB. For the MC14C89B, the nominal V_{IL} and V_{IH} thresholds are 0.95 and 1.30, respectively. The inputs are able to withstand ± 30 V referenced to ground. Should the input voltage exceed ground by more than ± 30 V, excessive currents will flow at the input pin. Open input pins will generate a logic high output, but good design practices dictate that inputs should never be left open.

The Response Control (RC) pins are coupled to the inputs through a resistor string. The RC pins provide for adjustment of the threshold voltages of the IC while preserving the amount of hysteresis. Figure 10 shows a typical application to adjust the threshold voltages. The RC pins also provide access to an internal resistor string which permits low pass filtering of the input signal within the IC. Like the input pins, the RC pins should not be taken above or below ground by more than ± 30 V or excessive currents will flow at these pins. The dependence of the low level threshold voltage (V_{IL}) upon R_{RC} and V_{bat} can be described by the following equation:

$$V_{IL} \approx \left\{ V_{0.09} - V_{bat} \left[\frac{505 \Omega}{R_{RC} (1.6) + 2.02 \text{ k}\Omega} \right] \right\} \left(\frac{5.32 \text{ k}\Omega + \frac{6.67 \times 10^6 \Omega^2}{R_{RC}}}{505 \Omega} \right) \quad (1)$$

MC14C89B

V_{IH} can be found by calculating for V_{IL} using equation (1) then adding the hysteresis for each device (0.35 for the MC14C89B or 0.95 V for the MC14C89AB). Figure 7 plots equation (1) for two values of V_{bat} and a range of R_{RC} .

If an RC pin is to be used for low pass filtering, the capacitor chosen can be calculated by the equation,

$$C_{RC} \approx \frac{1}{2.02 \text{ k}\Omega 2\pi f_{-3\text{dB}}} \quad (2)$$

where $f_{-3\text{dB}}$ represents the desired -3 dB roll-off frequency of the low pass filter.

Another feature of the MC14C89AB and MC14C89B is input noise rejection. The inputs have the ability to ignore pulses which exceed the V_{IH} and V_{IL} thresholds but are less than 1.0 μs in duration. As the duration of the pulse exceeds 1.0 μs , the noise pulse may still be ignored depending on its amplitude. Figure 8 is a graph showing typical input noise rejection as a function of pulse amplitude and pulse duration. Figure 8 reflects data taken for an input with an unconnected RC pin and applied to the MC14C89AB and MC14C89B.

Operating Temperature Range

The ambient operating temperature range is listed as -40°C to $+85^{\circ}\text{C}$, and the devices are designed to meet the EIA-232-E, EIA-562 and CCITT V.28 specifications over this temperature range. The timing characteristics are guaranteed to meet the specifications at $+25^{\circ}\text{C}$. The maximum ambient operating temperature is listed as $+85^{\circ}\text{C}$. However, a lower ambient may be required depending on system use (i.e., specifically how many receivers within a package are used), and at what current levels they are operating. The maximum power which may be dissipated within the package is determined by:

$$P_{D(\text{max})} = \frac{T_{J(\text{max})} - T_A}{R_{\theta JA}}$$

where: $R_{\theta JA}$ = thermal resistance (typ., $100^{\circ}\text{C}/\text{W}$ for the DIP and $125^{\circ}\text{C}/\text{W}$ for the SOIC packages);

$T_{J(\text{max})}$ = maximum operating junction temperature (150°C); and

T_A = ambient temperature.

$$P_D = \{[(V_{CC} - V_{OH}) \times |I_{OH}|] \text{ or } [(V_{OL}) \times |I_{OL}|]\}_{\text{each receiver}} + (V_{CC} \times I_{CC})$$

where: V_{CC} = positive supply voltage;

V_{OH} , V_{OL} = measured or estimated from Figure 2 and 3;

I_{CC} = measured quiescent supply current.

As indicated, the first term (in brackets) must be calculated and summed for each of the four receivers, while the last term is common to the entire package.

Figure 9. Application to Adjust Thresholds

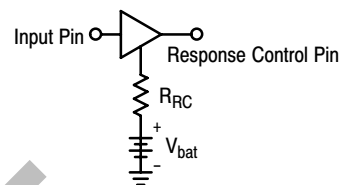

MC14C89B

OUTLINE DIMENSIONS

P SUFFIX PLASTIC PACKAGE CASE 646-06 ISSUE L

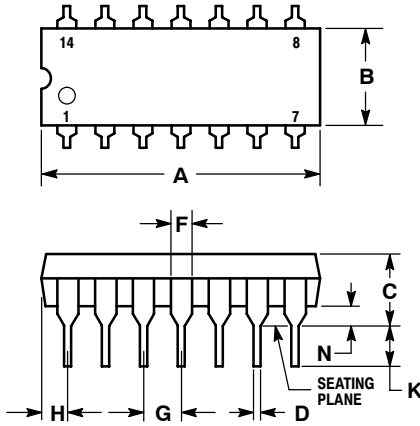

NOTES:

- LEADS WITHIN 0.13 (0.005) RADIUS OF TRUE POSITION AT SEATING PLANE AT MAXIMUM MATERIAL CONDITION.
- DIMENSION L TO CENTER OF LEADS WHEN FORMED PARALLEL.
- DIMENSION B DOES NOT INCLUDE MOLD FLASH.
- ROUNDED CORNERS OPTIONAL

DIM	INCHES		MILLIMETERS	
	MIN	MAX	MIN	MAX
A	0.715	0.770	18.16	19.56
B	0.240	0.260	6.10	6.60
C	0.145	0.185	3.69	4.69
D	0.015	0.021	0.38	0.53
F	0.040	0.070	1.02	1.78
G	0.100 BSC		2.54 BSC	
H	0.052	0.095	1.32	2.41
J	0.008	0.015	0.20	0.38
K	0.115	0.135	2.92	3.43
L	0.300 BSC		7.62 BSC	
M	0°	10°	0°	10°
N	0.015	0.039	0.39	1.01

D SUFFIX PLASTIC PACKAGE CASE 751A-03 (SO-14) ISSUE F

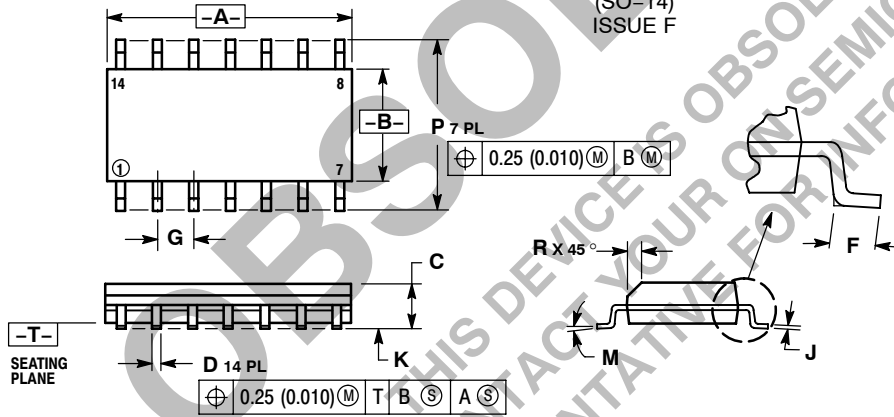

NOTES:

- DIMENSIONING AND TOLERANCING PER ANSI Y14.5M, 1982.
- CONTROLLING DIMENSION: MILLIMETER.
- DIMENSIONS A AND B DO NOT INCLUDE MOLD PROTRUSION.
- MAXIMUM MOLD PROTRUSION 0.15 (0.006) PER SIDE.
- DIMENSION D DOES NOT INCLUDE DAMBAR PROTRUSION. ALLOWABLE DAMBAR PROTRUSION SHALL BE 0.127 (0.005) TOTAL IN EXCESS OF THE D DIMENSION AT MAXIMUM MATERIAL CONDITION.

DIM	MILLIMETERS		INCHES	
	MIN	MAX	MIN	MAX
A	8.55	8.75	0.337	0.344
B	3.80	4.00	0.150	0.157
C	1.35	1.75	0.054	0.068
D	0.35	0.49	0.014	0.019
F	0.40	1.25	0.016	0.049
G	1.27 BSC		0.050 BSC	
J	0.19	0.25	0.008	0.009
K	0.10	0.25	0.004	0.009
M	0°	7°	0°	7°
P	5.80	6.20	0.228	0.244
R	0.25	0.50	0.010	0.019

ON Semiconductor and are registered trademarks of Semiconductor Components Industries, LLC (SCILLC). SCILLC reserves the right to make changes without further notice to any products herein. SCILLC makes no warranty, representation or guarantee regarding the suitability of its products for any particular purpose, nor does SCILLC assume any liability arising out of the application or use of any product or circuit, and specifically disclaims any and all liability, including without limitation special, consequential or incidental damages. "Typical" parameters which may be provided in SCILLC data sheets and/or specifications can and do vary in different applications and actual performance may vary over time. All operating parameters, including "Typicals" must be validated for each customer application by customer's technical experts. SCILLC does not convey any license under its patent rights nor the rights of others. SCILLC products are not designed, intended, or authorized for use as components in systems intended for surgical implant into the body, or other applications intended to support or sustain life, or for any other application in which the failure of the SCILLC product could create a situation where personal injury or death may occur. Should Buyer purchase or use SCILLC products for any such unintended or unauthorized application, Buyer shall indemnify and hold SCILLC and its officers, employees, subsidiaries, affiliates, and distributors harmless against all claims, costs, damages, and expenses, and reasonable attorney fees arising out of, directly or indirectly, any claim of personal injury or death associated with such unintended or unauthorized use, even if such claim alleges that SCILLC was negligent regarding the design or manufacture of the part. SCILLC is an Equal Opportunity/Affirmative Action Employer. This literature is subject to all applicable copyright laws and is not for resale in any manner.

PUBLICATION ORDERING INFORMATION

LITERATURE FULFILLMENT:

Literature Distribution Center for ON Semiconductor
P.O. Box 5163, Denver, Colorado 80217 USA
Phone: 303-675-2175 or 800-344-3860 Toll Free USA/Canada
Fax: 303-675-2176 or 800-344-3867 Toll Free USA/Canada
Email: orderlit@onsemi.com

N. American Technical Support: 800-282-9855 Toll Free
USA/Canada
Europe, Middle East and Africa Technical Support:
Phone: 421 33 790 2910
Japan Customer Focus Center
Phone: 81-3-5773-3850

ON Semiconductor Website: www.onsemi.com
Order Literature: <http://www.onsemi.com/orderlit>

For additional information, please contact your local Sales Representative

MC14C89B/D