



MOTOROLA
Semiconductors

MC1560, MC1561
MC1460, MC1461

MONOLITHIC VOLTAGE REGULATOR

... designed to deliver continuous load current up to 500 mA without use of an external power transistor.

- Electronic "Shut-Down" Control and Short-Circuit Protection
- Excellent Load Regulation (Low Output Impedance = 20 milliohms typ from dc to 100 kHz)
- High Power Capability: To 17.5 Watts
- Excellent Transient Response and Temperature Stability
- High Ripple Rejection = 0.002 %/V typ
- Single External Transistor Can Boost Load Current to Greater than 10 Amperes
- Input Voltages to 40 Volts (MC1561)

**POSITIVE-POWER-SUPPLY
VOLTAGE REGULATOR
INTEGRATED CIRCUIT**

EPITAXIAL PASSIVATED

AUGUST 1971 - DS 9104 R3
(Replaces DS 9104 R2)

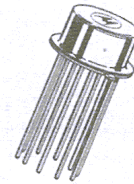

**G SUFFIX
METAL PACKAGE
CASE 602A**

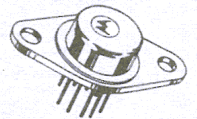

**R SUFFIX
METAL PACKAGE
CASE 614**

TYPICAL APPLICATION

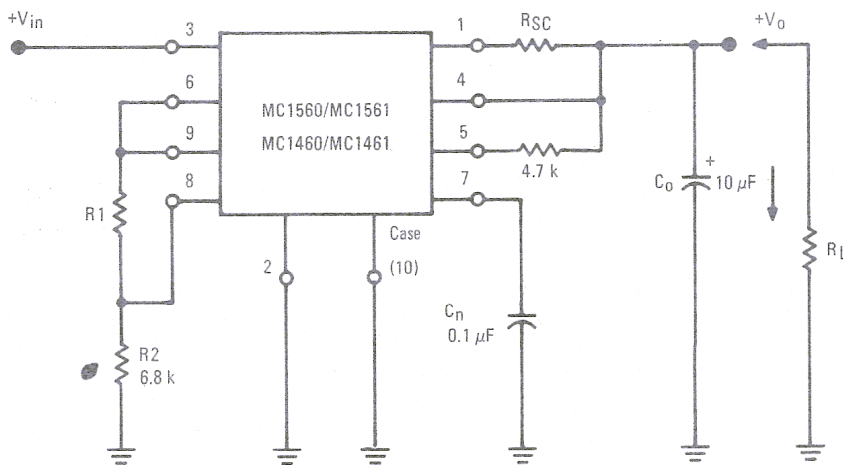

Select R1 to give desired V_0 :

$$R1 \approx (2 V_0 - 7.0) \text{ k}\Omega$$

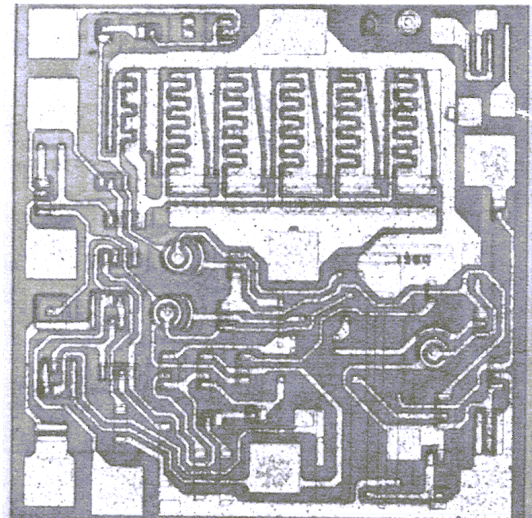

CIRCUIT SCHEMATIC

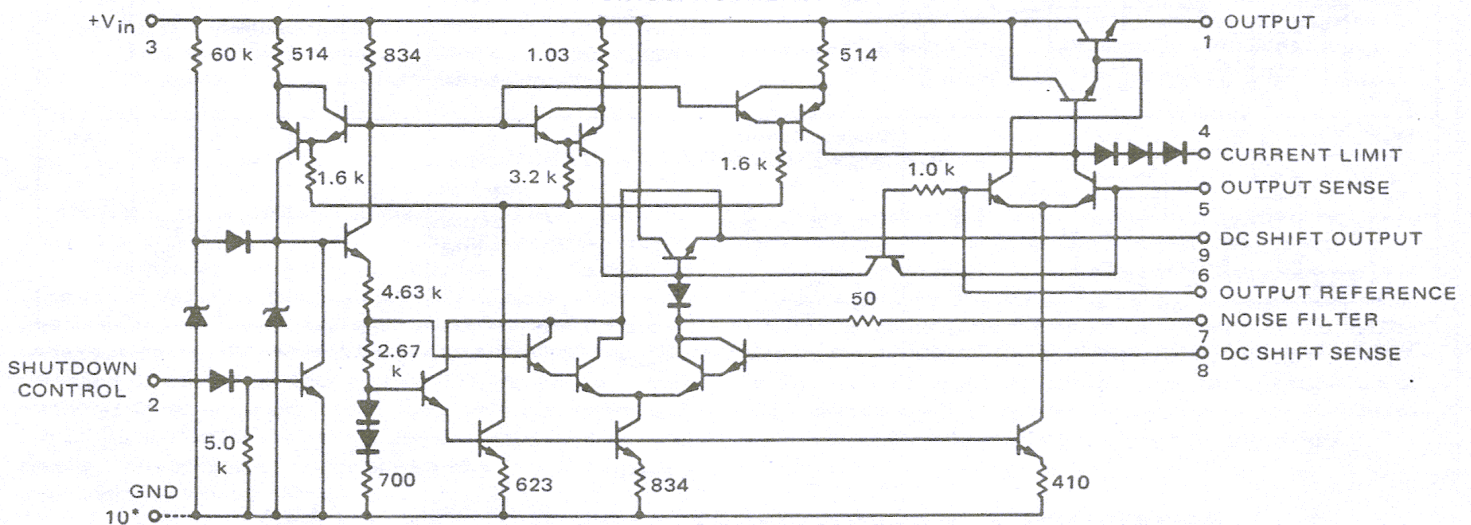

*Pin 10 is ground. "R" package - case is ground.

ELECTRICAL CHARACTERISTICS ($T_C = 25^\circ\text{C}$ unless otherwise noted) (Load Current = 100 mA for "R" Package device, unless otherwise noted) = 10 mA for "G" Package device,

| Characteristic Definitions (linear operation) | Characteristic | Symbol | Min | Typ | Max | Units |
|---|--|--------------|----------------------------|--------------------------|--------------------------|---------------|
| <p>($R_{SC} = 2.7$ ohms unless otherwise noted)</p> <p>CONNECTION FOR $V_O \geq 3.5$ V</p> <p>Select R1 to give desired V_O: $R_1 \approx (2 V_O - 7) \text{ k}\Omega$</p> | Input Voltage (See Note 1) (0 to $+75^\circ\text{C}$) (-55°C to $+125^\circ\text{C}$) | V_{in} | 9.0 8.5 | — | 20 20 | Vdc |
| | Output Voltage Range | V_O | 2.5 2.5 2.5 | — | 17 32 37 | Vdc |
| Reference Voltage ($V_{in} = 15$ V) (Pin 8 to ground) | V_{ref} | 3.2 | 3.5 | 3.8 | Vdc | |
| Minimum Input-Output Voltage Differential (See Note 2) ($R_{SC} = 0$) | $V_{in} - V_O$ | — | 2.1 | 3.0 | Vdc | |
| Bias Current ($V_{in} = 15$ V) ($I_L = 1.0$ mA, $R_2 = 6.8$ k Ω , $I_B = I_{in} - I_L$) | I_B | — | 5.0 4.0 | 12 9.0 | mA | |
| Output Noise ($C_n = 0.1$ μF , $f = 10$ Hz to 5.0 MHz) | v_n | — | 0.150 | — | mV (rms) | |
| Temperature Coefficient of Output Voltage (See Note 3) (0 to $+75^\circ\text{C}$) (-55° to $+125^\circ\text{C}$) | TC_{V_O} | — | ± 0.002 ± 0.002 | — | %/ $^\circ\text{C}$ | |
| Operating Load Current Range* ($R_{SC} \leq 0.3$ ohms) R Package ($R_{SC} \leq 2.0$ ohms) G Package | I_L | 1.0 | — | 500 200 | mA | |
| <p>$+V_{in} = 17$ Vdc</p> <p>$V_{in} = 1.0$ vrms $f = 1.0$ kHz</p> <p>Select R2 to give desired V_O: $R_2 \approx (2 V_O) \text{ k}\Omega$ Select R1: $R_1 \approx (7.0 \text{ k}\Omega - R_2) \text{ k}\Omega$</p> | Input Regulation (% change in output voltage per 1-volt change in input voltage) | Reg_{in} | — | 0.003 0.002 | 0.030 0.015 | %/ V_O |
| <p>$+15$ V</p> | Load Regulation $T_J = \text{Constant}$ ($1.0 \text{ mA} \leq I_L \leq 20 \text{ mA}$) | Reg_{load} | — | 0.5 0.3 0.7 0.4 | 2.0 1.2 2.4 1.6 | mV |
| <p>$+V_{in}$</p> | Output Impedance (See Note 6) ($R_{SC} = 1.0$ ohms, $f = 10$ kHz, $V_{in} = 14$ Vdc) ($I_L = 25$ mA for G Package) | Z_{out} | — | 25 15 35 20 | 100 60 120 80 | milli-ohms |
| <p>$+V_{in}$</p> | Shutdown Current ($V_{in} = 20$ Vdc) ($V_{in} = 35$ Vdc) | I_{sd} | — | 80 20 140 70 | 300 50 500 150 | μA |
| <p>*Operating Load Current is also limited by dc Safe Operating Area (see Figures 15A and 15B). Care must be taken not to exceed the dc Safe Operating Area at any time.</p> | | | | | | |



MAXIMUM RATINGS ($T_C = +25^{\circ}\text{C}$ unless otherwise noted)

| Rating | Symbol | Value | | Unit |
|--|--------------|-----------------|--------------------------------|------------------------------|
| Input Voltage | V_{in} | MC1460, MC1560 | 20 | Vdc |
| | | MC1461 | 35 | |
| | | MC1561 | 40 | |
| Load Current | I_L | G Package | 250 | mA |
| | | R Package | 600 | |
| Current, Pin 2 | $I_{pin\ 2}$ | 10 | 10 | mA |
| Current, Pin 9 | $I_{pin\ 9}$ | 5.0 | 5.0 | |
| Power Dissipation and Thermal Characteristics | | | | |
| $T_A = 25^{\circ}\text{C}$ | | | | |
| Derate above $T_A = 25^{\circ}\text{C}$ | | | | |
| Thermal Resistance, Junction to Air | | θ_{JA} | 184 | $^{\circ}\text{C}/\text{W}$ |
| $T_C = 25^{\circ}\text{C}$ | | | | |
| Derate above $T_C = 25^{\circ}\text{C}$ | | P_D | 1.8 | Watts |
| Thermal Resistance, Junction to Case | | $1/\theta_{JC}$ | 14.4 | $\text{mW}/^{\circ}\text{C}$ |
| | | θ_{JC} | 69.4 | $^{\circ}\text{C}/\text{W}$ |
| Operating and Storage Junction Temperature Range | | T_J, T_{stg} | -65 to +150 $^{\circ}\text{C}$ | |

*The MC1460R and MC1560R are limited to 12 watts maximum by the voltage and current maximum ratings.

OPERATING TEMPERATURE RANGE

| Ambient Temperature | T_A | Range | | Unit |
|----------------------------------|-------|----------|-------------|--------------------|
| MC1460, MC1461 MC1560, MC1561 | T_A | 0 to +75 | -55 to +125 | $^{\circ}\text{C}$ |
| | | | | |

Note 1. "Minimum Input Voltage" is the minimum "total instantaneous input voltage" required to properly bias the internal zener reference diode. For output voltages greater than approximately 5.5 Vdc the minimum "total instantaneous input voltage" must increase to the extent that it will always exceed the output voltage by at least the "input-output voltage differential".

Note 2. This parameter states that the MC1560/1561 and MC1460/1461 will regulate properly with the input-output voltage differential ($V_{in} - V_O$) as low as 2.7 Vdc and 3.0 Vdc respectively. Typical units will regulate properly with ($V_{in} - V_O$) as low as 2.1 Vdc as shown in the typical column.

Note 3. "Temperature Coefficient of Output Voltage" is defined as:

$$\text{MC1560, MC1561 } TC_{V_O} = \frac{\pm (V_{O\ max} - V_{O\ min})(100)}{2 (180^{\circ}\text{C})(V_O @ 25^{\circ}\text{C})} = \%/^{\circ}\text{C}$$

$$\text{MC1460, MC1461 } TC_{V_O} = \frac{\pm (V_{O\ max} - V_{O\ min})(100)}{2 (75^{\circ}\text{C})(V_O @ 25^{\circ}\text{C})} = \%/^{\circ}\text{C}$$

The output-voltage adjusting resistors (R1 and R2) must have matched temperature characteristics in order to maintain a constant ratio independent of temperature.

Note 4. The input signal can be introduced by use of a transformer which will allow the output of an audio oscillator to be coupled in series with the dc input to the regulator. (The large ac input impedance of the regulator will not load the oscillator.) A 24 V, 1.0 ampere filament transformer with the audio oscillator connected to the 110 V primary winding is satisfactory for this test. $V_{in} \approx 1.0\ \text{V (rms)}$.

Note 5. Load regulation is specified for small ($\leq +17^{\circ}\text{C}$) changes in junction temperature. Temperature drift effect must be taken into account separately for conditions of high junction temperature changes due to the thermal feedback that exists on the monolithic chip.

$$\text{Load Regulation} = \frac{V_O | I_L = 1.0\ \text{mA} - V_O | I_L = 50\ \text{mA}}{V_O | I_L = 1.0\ \text{mA}} \times 100$$

Note 6. The resulting low level output signal (v_O) will require the use of a tuned voltmeter to obtain a reading. Special care should be used to insure that the measurement technique does not include connection resistance, wire resistance, and wire lead inductance (i.e., measure close to the case). Note that No. 22 AWG hook-up wire has approximately 4.0 milliohms/in. dc resistance and an inductive reactance of approximately 10 milliohms/in. at 100 kHz. Avoid use of alligator clips or banana plug-jack combination.

GENERAL OPERATING INFORMATION

There is a general tendency to consider a voltage regulator as simply a dc circuit and to prepare breadboard construction accordingly. The excellent high-frequency performance and fast response capability of this integrated-circuit regulator, however, makes extra breadboarding care worthwhile when compared with the limited performance achieved in other regulators when low-frequency transistors are used in the feedback amplifier. Due to the use of VHF transistors in the integrated circuit, some VHF care (short, well-dressed leads) must be exercised in the construction and wiring of circuits ("printed-circuit" boards provide an excellent component interconnection technique).

The circuit must be grounded by a low-inductance connection to the case of the "R" package, or to pin 10 of the "G" package.

A series 4.7-k Ω resistor at Pin 5 (Figure 1) will eliminate any VHF instability problems which may result from lead lengths longer than a few inches at the regulator output. The resistor body should be as close to Pin 5 as physically possible (< 1/2 inch) although the length of the lead to the load is not critical. If temperature stability is of major concern, a 4.7-k Ω resistor should also be placed in series with Pin 6 in order to cancel any drift due to bias current changes.

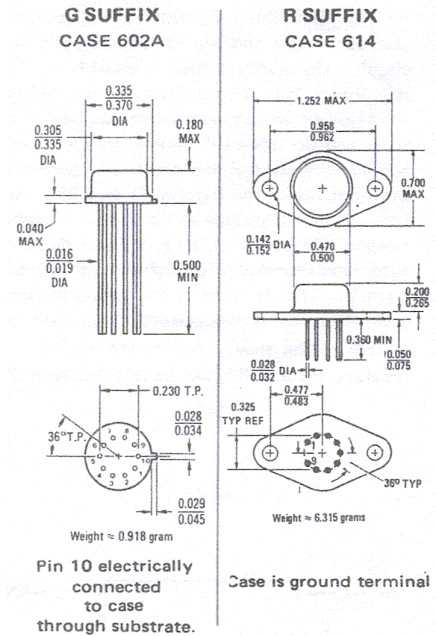

To convert inches to millimeters multiply by 25.4.



MOTOROLA Semiconductor Products Inc.

If long input leads are used, it may be necessary to bypass Pin 3 with a 0.1- μF capacitor (to ground).

The "Shut-Down Control", Pin 2, can be actuated for all possible output voltages and any values of C_0 and C_n with no damage to the circuit. The standard logic levels of RTL, DTL, or TTL can be used (see Figure 20). This control can be used to eliminate power consumption by circuit loads which can be put in a "standby" mode, as an ac and dc "squelch" control for communications circuits, and as a dissipation control to protect the regulator under sustained output short-circuiting (see Figures 21 and 25). As the magnitude of the input-threshold voltage at Pin 2 depends directly upon the junction temperature of the IC chip, a fixed dc voltage at Pin 2 will cause automatic shut-down for high junction temperatures (see Figure 23, a and b). This will protect the chip, independent of the heat sinking used, the ambient temperature, or the input or output voltage levels.

Due to the small value of input current at Pin 8, the external resistors, R1 and R2, can be selected with little regard to their par-

allel resistance. Further, no match to a diffused-resistor temperature coefficient is required; but R1 and R2 should have the same temperature coefficient to keep their ratio independent of temperature.

C_n values in excess of 0.1 μF are rarely needed to reduce noise. In cases where more output noise can be tolerated, a smaller capacitor can be used (C_n min. \approx 0.001 μF).

The connection to Pin 5 can be made by a separate lead directly to the load. Thus "remote sensing" can be achieved and undesired impedances (including that of a milliammeter used to measure I_L) can be greatly reduced in their effect on Z_{OUT} . A 10-ohm resistor placed from pin 1 to pin 5 (close to the IC) will eliminate undesirable lead-inductance effects.

Short-circuit current-limiting is achieved by selecting a value for RSC which will threshold the internal diode string when the desired maximum load current flows (see Figure 5). If the device dissipation and dc safe area limits (Figure 15) are not exceeded, it can be continuously short-circuited at the output without damage.

TYPICAL CONNECTIONS

FIGURE 1 - CONNECTION FOR $V_0 \geq 3.5 \text{ V}$

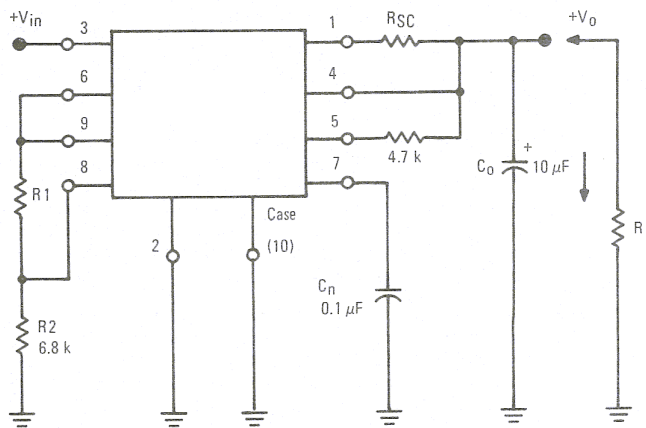

Select R1 to give desired V_0 : $R1 \approx (2 V_0 - 7.0) \text{ k}\Omega$

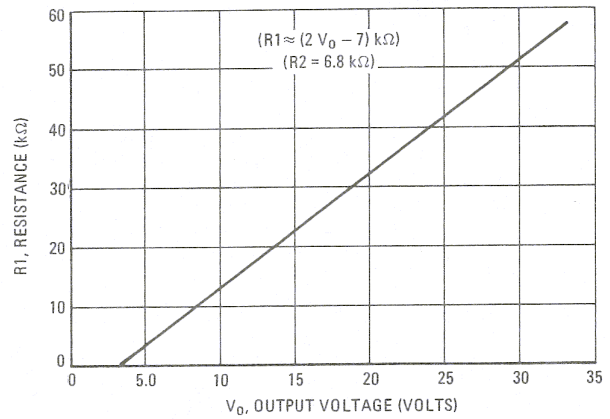
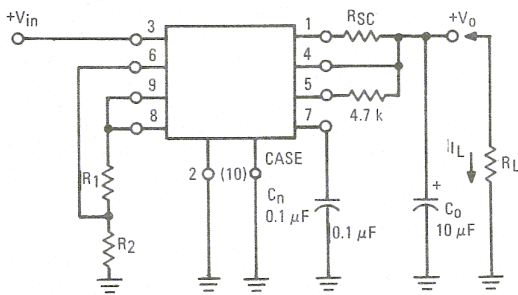
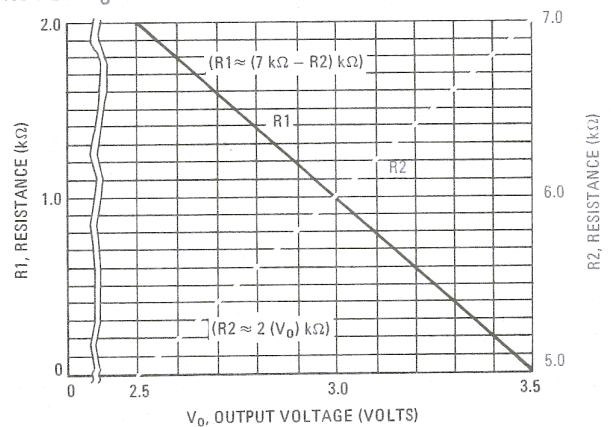

FIGURE 2 - CONNECTIONS FOR $V_0 \leq +3.5 \text{ V}$



Select R2 to give desired V_0 :
 $R2 \approx (2 V_0) \text{ k}\Omega$
 Select R1:
 $R1 \approx 7.0 \text{ k}\Omega - R2$



Circuit diagrams utilizing Motorola products are included as a means of illustrating typical semiconductor applications; consequently, complete information sufficient for construction purposes is not necessarily given. The information has been carefully checked and

is believed to be entirely reliable. However, no responsibility is assumed for inaccuracies. Furthermore, such information does not convey to the purchaser of the semiconductor devices described any license under the patent rights of Motorola Inc. or others.



TYPICAL CHARACTERISTICS

Unless otherwise stated: $C_n = 0.1 \mu F$, $C_o = 10 \mu F$, $V_o \text{ nom} = +5.0 \text{ Vdc}$, $V_{in} \text{ nom} = +9.0 \text{ Vdc}$, $T_C = +25^\circ C$, $I_L > 200 \text{ mA}$ for "R" Package only.

FIGURE 3 – INPUT TRANSIENT RESPONSE

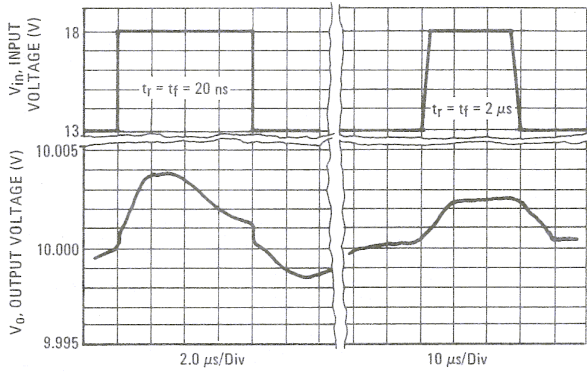

FIGURE 4 – LOAD TRANSIENT RESPONSE

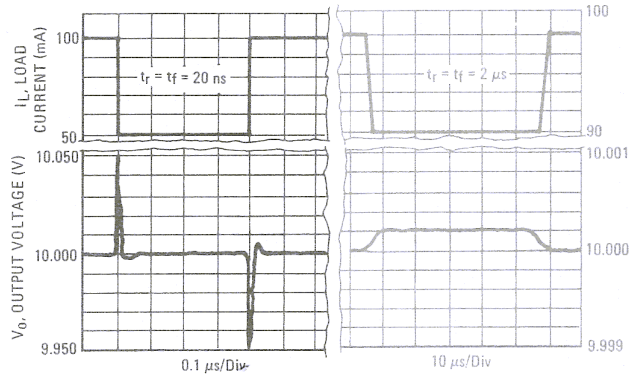

FIGURE 5 – SHORT-CIRCUIT CURRENT versus R_{SC}

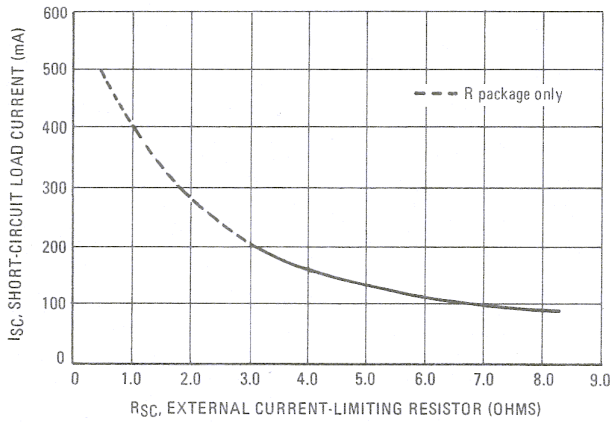

FIGURE 6 – CURRENT-LIMITING CHARACTERISTICS

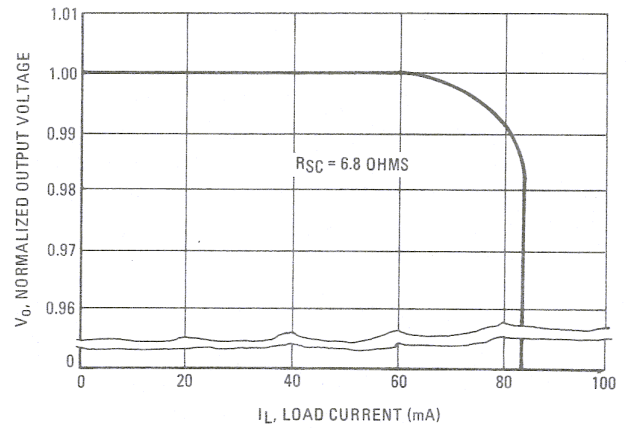

FIGURE 7 – FREQUENCY-DEPENDENCE OF OUTPUT IMPEDANCE

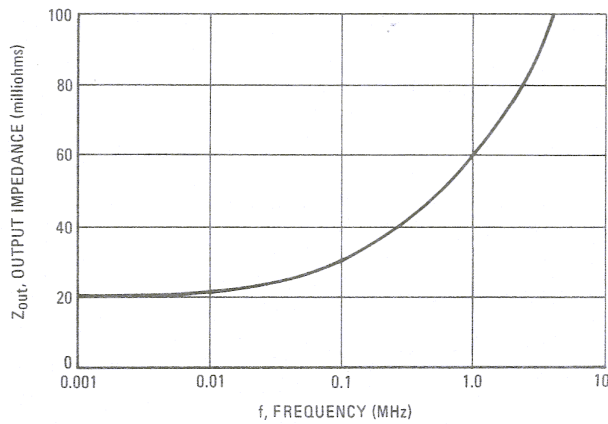
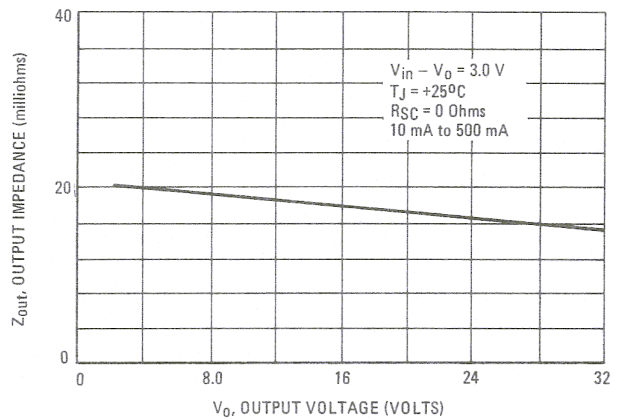

FIGURE 8 – DEPENDENCE OF OUTPUT IMPEDANCE ON OUTPUT VOLTAGE



MOTOROLA Semiconductor Products Inc.

TYPICAL CHARACTERISTICS (continued)

Unless otherwise stated: $C_n = 0.1 \mu\text{F}$, $C_o = 10 \mu\text{F}$, $V_o \text{ nom} = +5.0 \text{ Vdc}$, $V_{in} \text{ nom} = +9.0 \text{ Vdc}$,
 $T_C = +25^\circ\text{C}$, $I_L > 200 \text{ mA}$ for "R" Package only.

FIGURE 9 – OUTPUT IMPEDANCE versus R_{SC}

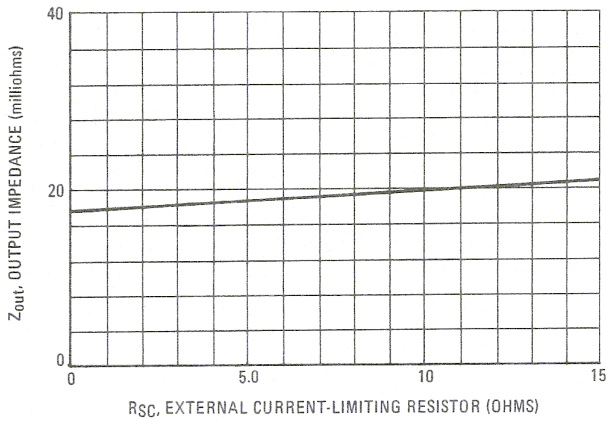

FIGURE 10 – FREQUENCY-DEPENDENCE OF INPUT REGULATION

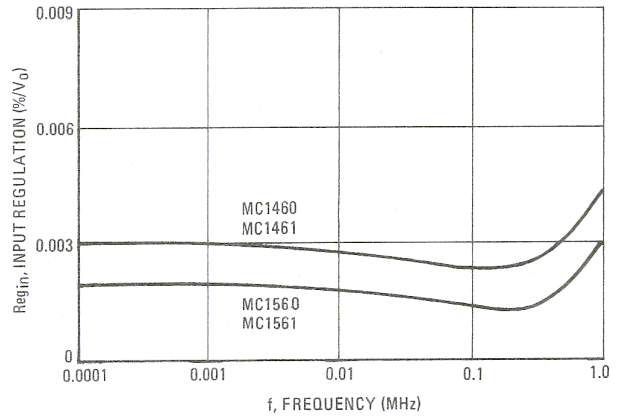

FIGURE 11 – BIAS CURRENT versus INPUT VOLTAGE

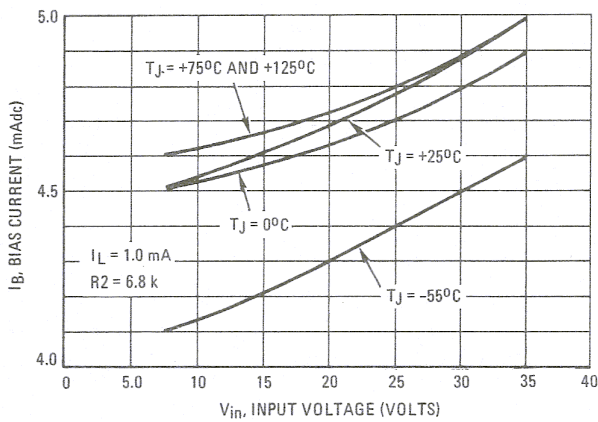

FIGURE 12 – EFFECT OF LOAD CURRENT ON INPUT-OUTPUT VOLTAGE DIFFERENTIAL

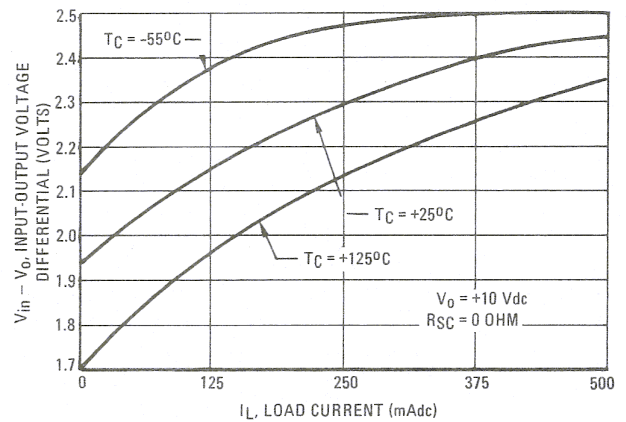

FIGURE 13 – EFFECT OF INPUT-OUTPUT VOLTAGE DIFFERENTIAL ON INPUT REGULATION

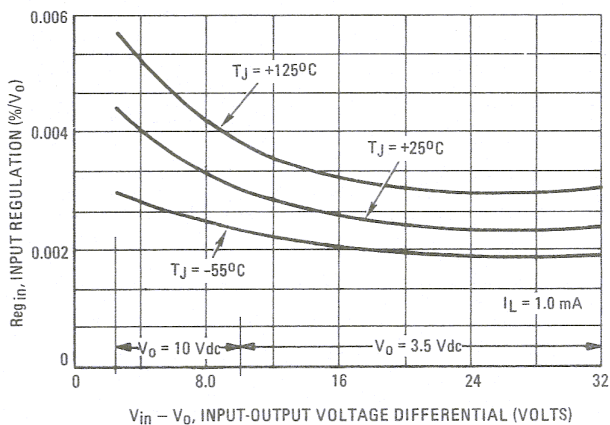
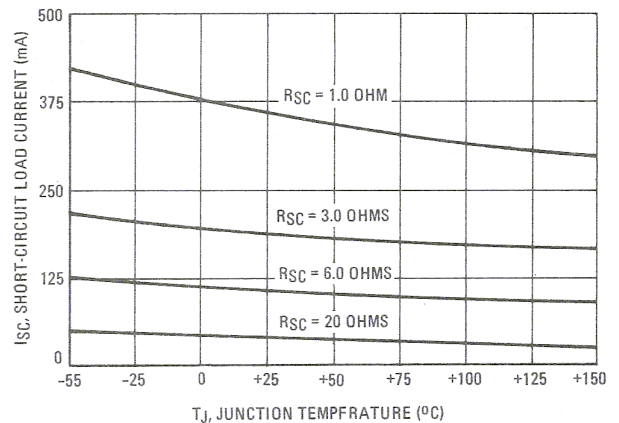

FIGURE 14 – TEMPERATURE DEPENDENCE OF SHORT-CIRCUIT LOAD CURRENT



TYPICAL CHARACTERISTICS (continued)

FIGURE 15a – DC SAFE OPERATING AREA ("G" PACKAGE)

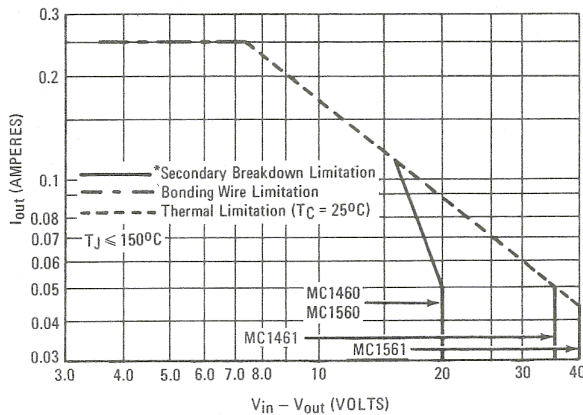
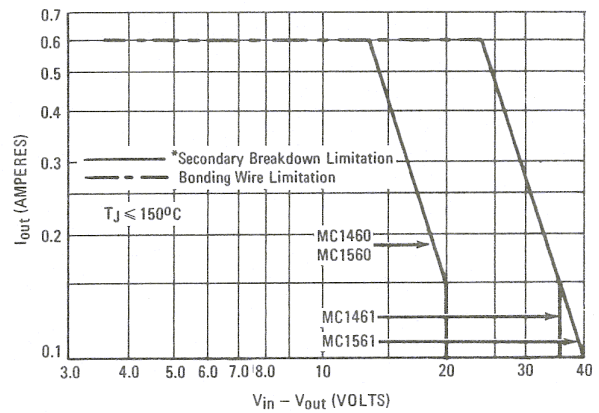

FIGURE 15b – DC SAFE OPERATING AREA ("R" PACKAGE)



*See Application Note AN-415 for an explanation of safe area and second breakdown.

TYPICAL APPLICATIONS

(Circuit shown in blue is added to the basic circuit of Figure 1 to achieve the specified application).

FIGURE 16 – A LABORATORY SUPPLY, 0 TO 25 V

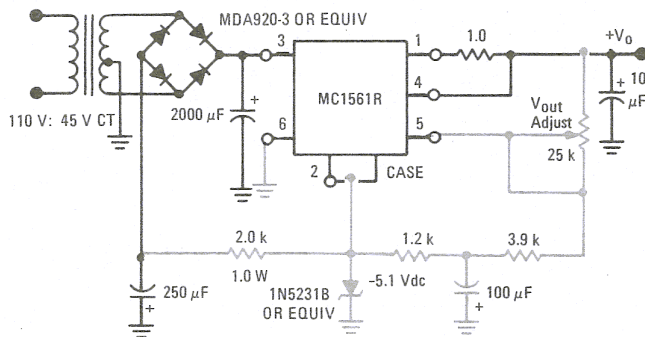

FIGURE 17 – PROVIDING TWO REGULATED OUTPUT VOLTAGES

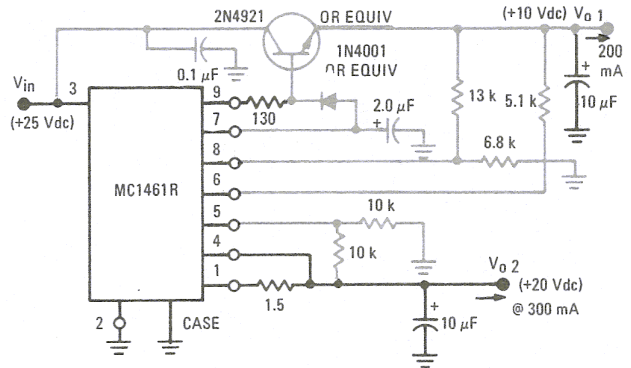
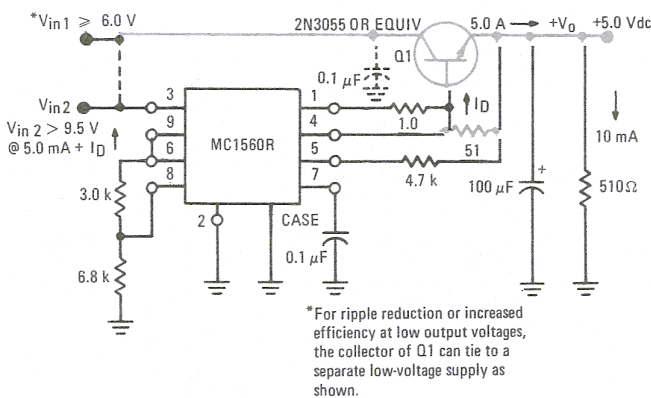
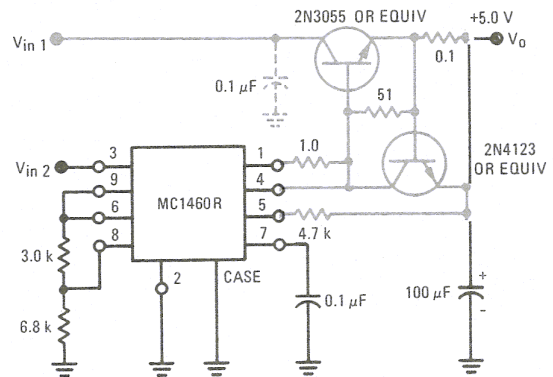

FIGURE 18 – NPN CURRENT BOOST CIRCUITS



*For ripple reduction or increased efficiency at low output voltages, the collector of Q1 can tie to a separate low-voltage supply as shown.



MOTOROLA Semiconductor Products Inc.

TYPICAL APPLICATIONS (continued)

(Circuit shown in blue is added to the basic circuit of Figure 1 to achieve the specified application)

FIGURE 19 – PNP CURRENT BOOST CIRCUIT

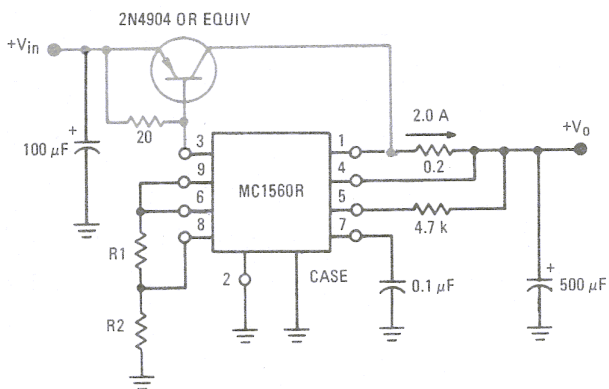
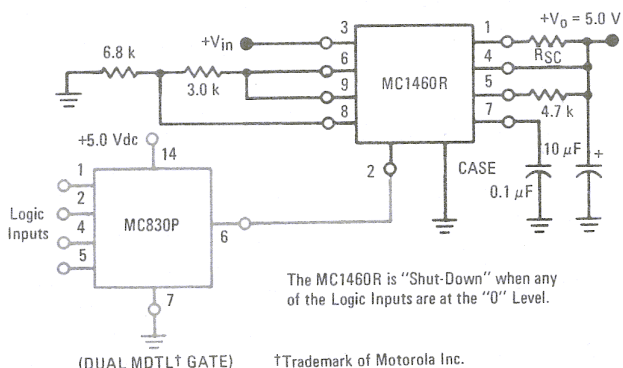

FIGURE 20 – ELECTRONIC SHUT-DOWN USING A MDTL GATE



The MC1460R is "Shut-Down" when any of the Logic Inputs are at the "0" Level.

†Trademark of Motorola Inc.

FIGURE 21 – AUTOMATIC LATCH INTO SHUT-DOWN WHEN OUTPUT IS SHORT-CIRCUITED WITH MANUAL RE-START

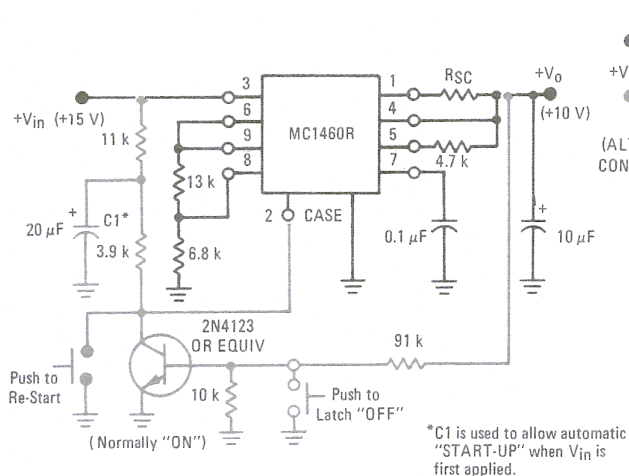

*C1 is used to allow automatic "START-UP" when V_{in} is first applied.

FIGURE 22 – SCR "CROWBAR" OVER VOLTAGE PROTECTION

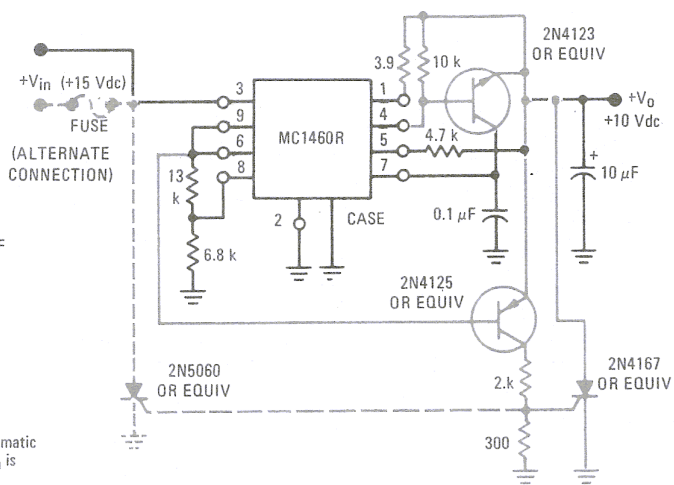
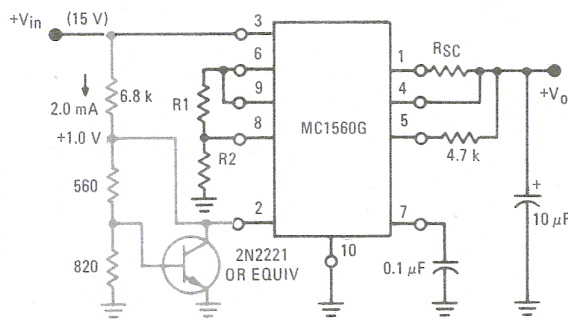
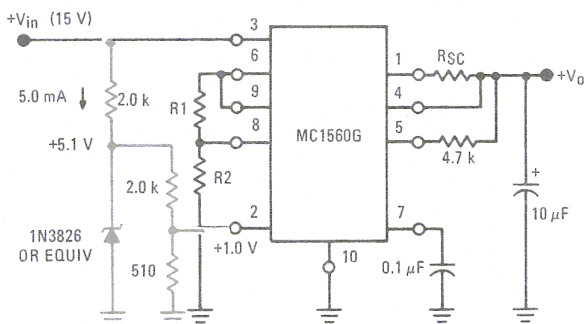

FIGURE 23 – LIMITING MAXIMUM JUNCTION TEMPERATURE

FIGURE a – USING A ZERO TC REFERENCE

FIGURE b – USING A T_A REFERENCE

$$V_{pin 2} \text{ (for shut-down)} \approx 1.38 - 3.4 \times 10^{-3} (T_J - 25^\circ\text{C})$$



TYPICAL APPLICATIONS (continued)

(Circuit shown in blue is added to the basic circuit of Figure 1 to achieve the specified application).

FIGURE 24 – THERMAL SHUTDOWN WHEN USING EXTERNAL PASS TRANSISTOR

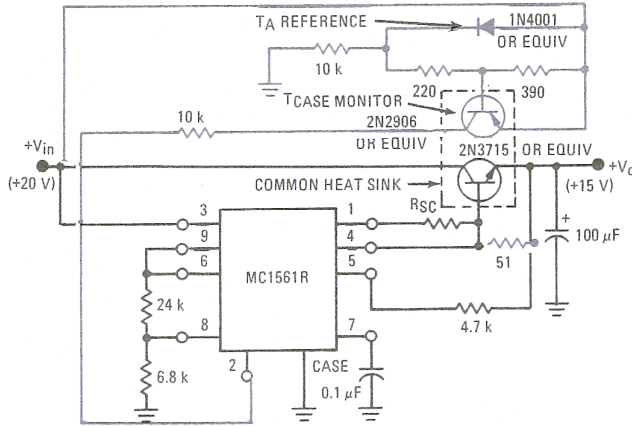

FIGURE 26 – CONNECTION FOR A NEGATIVE OUTPUT VOLTAGE

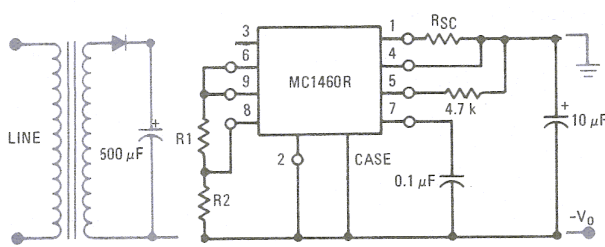

FIGURE 25 – LOW DUTY CYCLE SHORT CIRCUIT PROTECTION WITH AUTOMATIC RESET

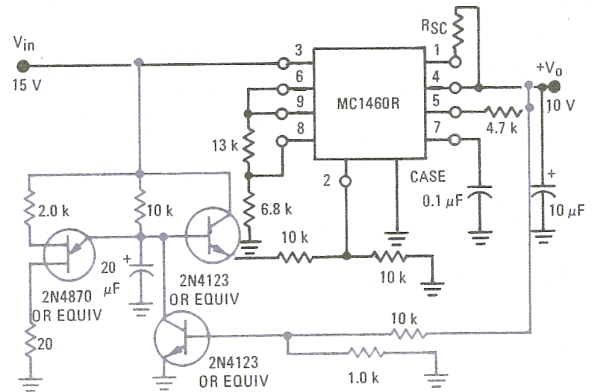

FIGURE 27 – DIGITALLY CONTROLLED 3-TERMINAL NEGATIVE REGULATOR

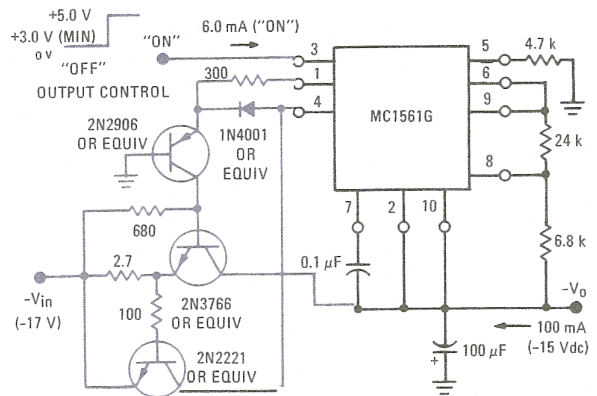
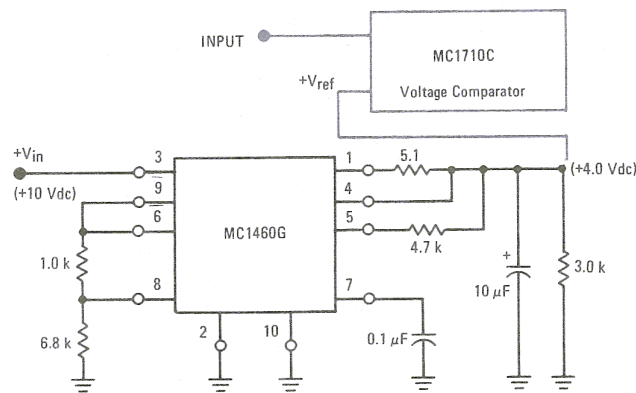

FIGURE 28 – A ZERO TC ADJUSTABLE "ZENER" REFERENCE



MOTOROLA Semiconductor Products Inc.

GENERAL INFORMATION

Latch-up of these and other regulators can occur if:

1. There are plus and minus voltages available
2. A load exists between V_o^+ and V_o^- (This "common load" may be something inconspicuous —e.g. an operational amplifier. Nearly everyone who uses + and - voltages will have a common load from V^+ to V^-).
3. V_{in}^+ and V_{in}^- are not applied at the same time.

The above conditions result in one of the two outputs becoming reverse-biased which prevents the regulator from turning "on". Latch-up can be prevented by the circuit configurations shown in Figure 29 and 30.

FIGURE 29

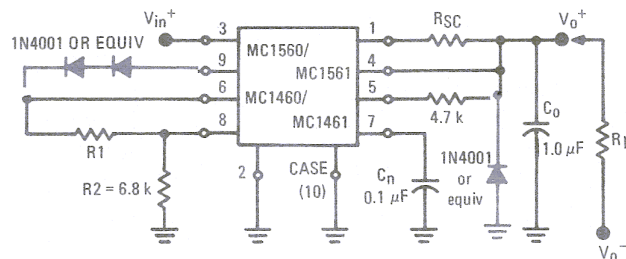
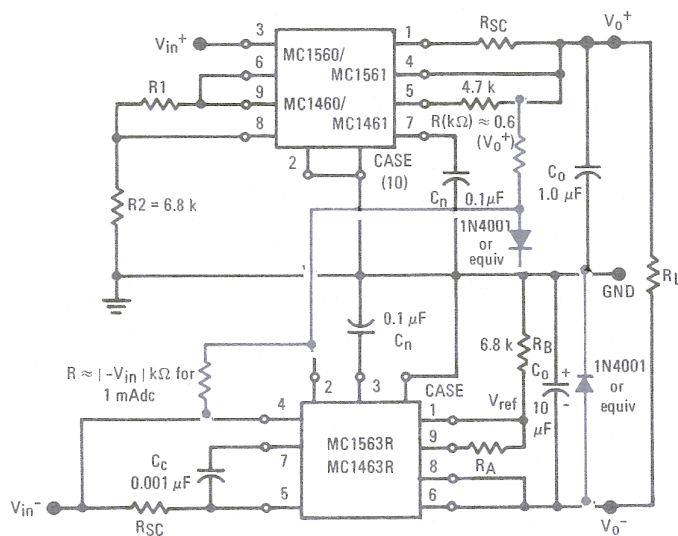

FIGURE 30



MOTOROLA Semiconductor Products Inc.



VOLTAGE REGULATOR CONSTRUCTION USING THE MC1460, MC1461, MC1560, MC1561 INTEGRATED CIRCUITS

FIGURE 31 — Regulator Layout Using Power Package For Load Currents Up To 500 mA

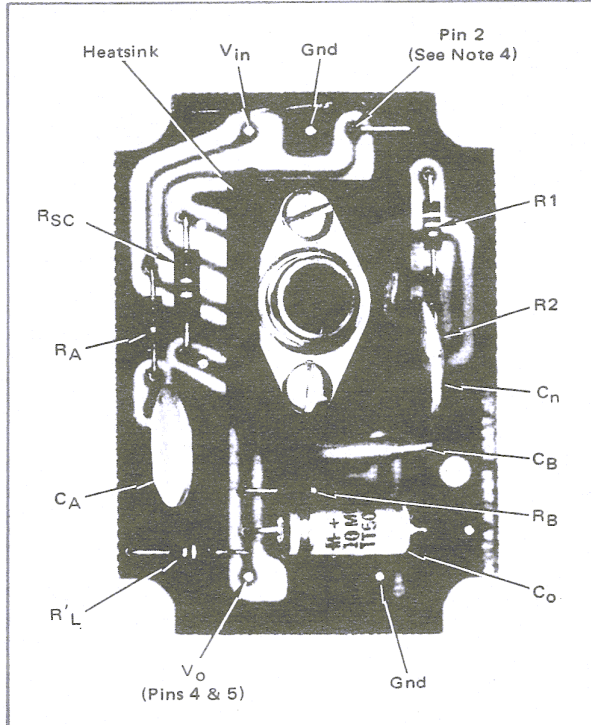
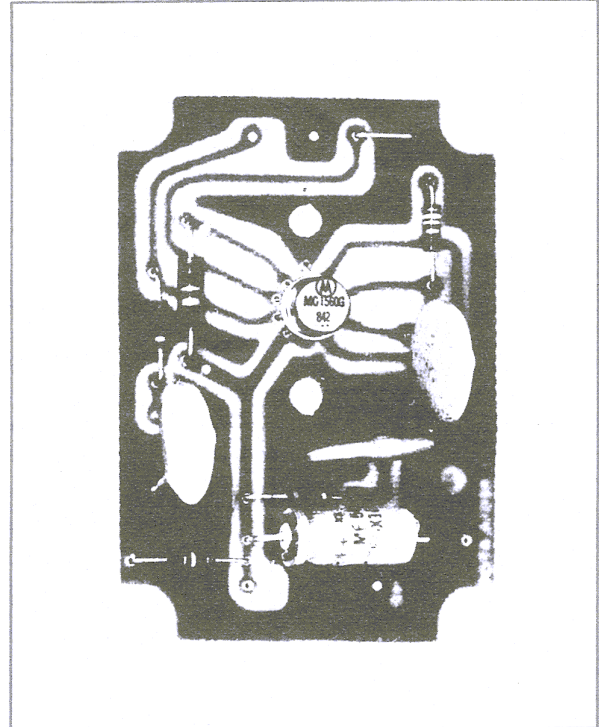

FIGURE 32 — Regulator Layout For Load Currents Up To 200 mA



There is a general tendency to consider a voltage regulator as simply a dc circuit and to prepare circuit layout accordingly. The excellent high-frequency performance and fast response capability of this integrated-circuit regulator, however, makes extra layout care worthwhile. Since short, well-dressed leads must be used, printed-circuit boards provide an excellent component interconnection technique.

The circuit layout, shown in Figure 31 for the "R" or power package IC, applies also to the lower power "G" package circuit shown in Figure 32. The R package circuits will deliver up to 500 mA into a load and the G package, 200 mA.

The circuit schematic, Figure 33, is for output voltages above 3.5 Vdc and the parts list is as follows:

PARTS LIST

| Component | Value | Description |
|-----------------|----------------|--|
| R1 | Select | } 1/4 Watt Carbon — See Note 1 |
| R2 | 6.8 k Ω | |
| R _{SC} | Select | 1/2 Watt Carbon — See Note 2 |
| *R _A | 3 Ω | } 1/4 Watt Carbon |
| *R _B | 3 Ω | |
| *R _L | Select | for current of 1 mA minimum |
| C _O | 10 μ F | Sprague 1500 Series, Dickson D10C Series or Equivalent |
| C _n | 0.1 μ F | Ceramic Disc — |
| *C _A | 0.1 μ F | } Centralab DDA104, Sprague TG-P10, or Equivalent |
| *C _B | 0.1 μ F | |
| *Heatsink | | — Thermalloy #6168 — IERC LB 66B1-77U series |
| *Socket | | (Not Shown) Robinson Nugent #0001306 Electronic Molding Corp. #6341-210-1, 6348-188-1, 6349-188-1 |

*Optional Parts, See Note 3 on next page.



MOTOROLA Semiconductor Products Inc.

VOLTAGE REGULATOR CONSTRUCTION (continued)

Note 1. The value of R1 is approximately $(2 V_O - 7) \text{ k}\Omega$, where V_O is the desired output voltage (3.5 V or greater). Optimum temperature stability can be achieved if R1 and R2 have the same temperature coefficient.

Note 2. R_{SC} is a current sensing resistor for short circuit protection. See Figure 5 for a "Short-Circuit Load Current versus R_{SC} " curve.

Note 3. In cases where long leads are used at the input or output of the regulator, bypass networks $R_A C_A$ and $R_B C_B$ might be necessary to eliminate parasitic oscillation.

With no load, it is possible for a charge to develop on C_O due to leakage currents. R'_L is recommended to insure a minimum load current of 1 mA.

Note 4. It is recommended that Pin 2 (shut-down control) be grounded when not in use. When used, drive current to Pin 2 must be limited to 10 mA maximum.

FIGURE 33 — Schematic of Complete Regulator Showing Both Necessary and Optional Components

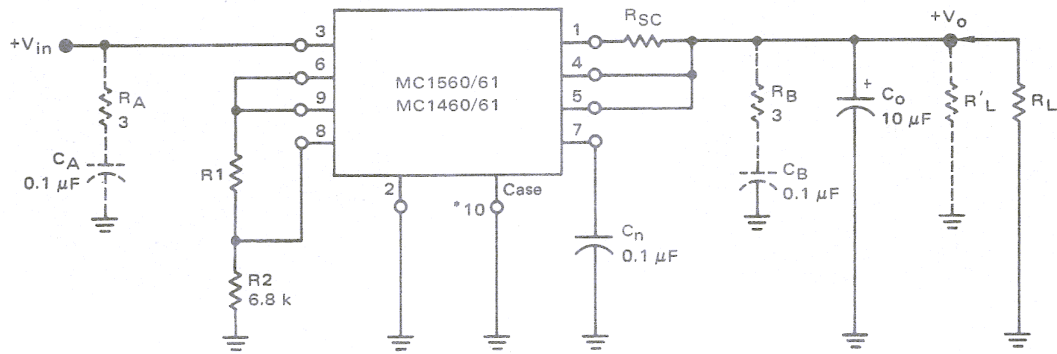

* G-Package Pin 10 is ground, R package Case is ground.

FIGURE 34 — Typical Printed Circuit Board Layout

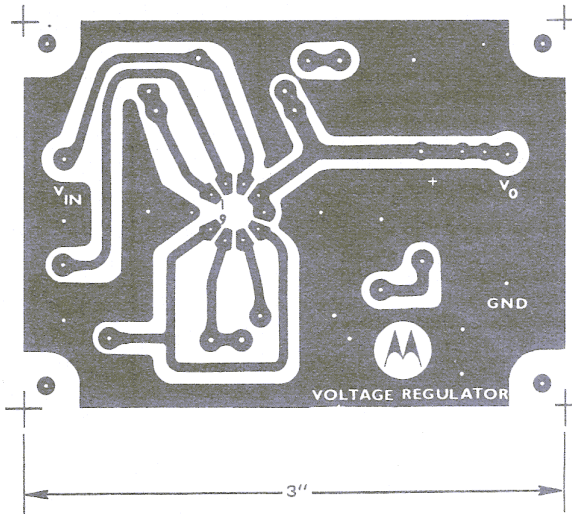

MOTOROLA Semiconductor Products Inc.