

LOW EMI CLOCK GENERATOR

MK1709

Description

The MK1709 generates a low EMI output clock from a clock input. The part is designed to dither the LCD interface clock for flat panel graphics controllers. The device uses ICS' proprietary mix of analog and digital Phase Locked Loop (PLL) technology to spread the frequency spectrum of the output, thereby reducing the frequency amplitude peaks by several dB.

The MK1709 offers centered spread from a high speed clock input. Refer to the MK1714-01/02 for a crystal input and the widest selection of input frequencies and multipliers.

ICS offers many other clocks for computers and computer peripherals. Consult us when you need to remove crystals and oscillators from your board.

Features

- Packaged in 8-pin SOIC (MK1709S) and in 8-pin TSSOP (MK1709AG)
- Available in lead (Pb) free package
- Provides a spread spectrum output clock
- Supports flat panel controllers
- Guaranteed to +85°C operation
- Accepts a clock input, provides same frequency dithered output
- Good for all VGA modes from 40 to 167 MHz
- Peak reduction by 7dB - 14dB typical on 3rd - 19th odd harmonics
- Low EMI feature can be disabled
- Includes power-down
- Operating voltage of 3.3 V
- Advanced, low-power CMOS process

Block Diagram

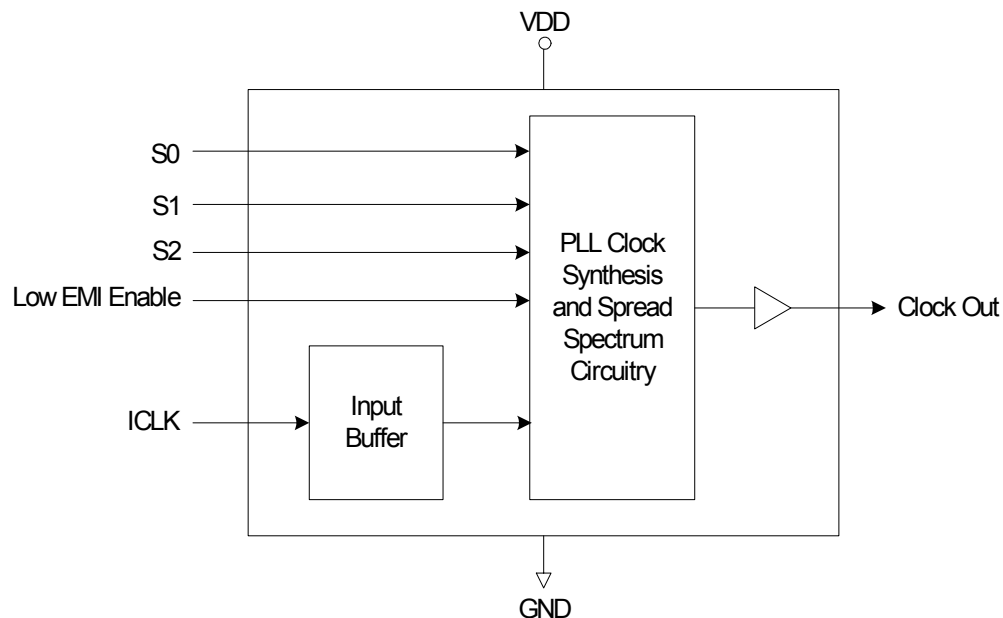

Pin Assignment

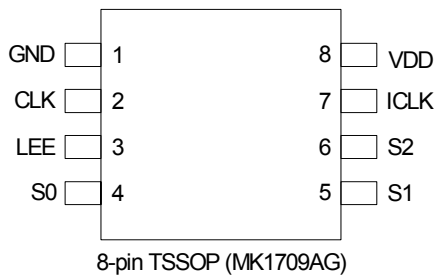
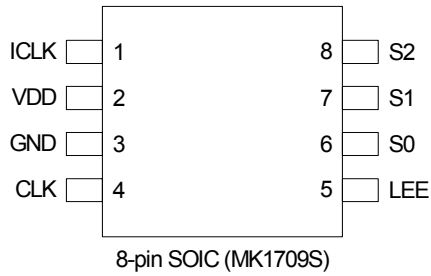

Spread Percentage and Direction Select Table

S2 Pin 8 (1709S) Pin 6 (1709AG)	S1 Pin 7 (1709S) Pin 5 (1709AG)	S0 Pin 6 (1709S) Pin 4 (1709AG)	Frequency Range	Spread Percentage (%)
0	0	0	40-50	±0.9
0	0	M	40-50	±0.7
0	0	1	40-50 (MK1709S) 25-50 (MK1709AG)	±0.8
0	M	0	40-50 (MK1709S) 25-50 (MK1709AG)	±0.6
0	M	M	40-50	±1.1
0	M	1	50 -100	±0.6
0	1	0	50 -100	±0.7
0	1	M	50 -100	±0.8
0	1	1	Power Down	—
1	0	0	50 -100	±0.9
1	0	M	50 -100	±1.1
1	0	1	100-165	±0.7
1	M	0	100-165	±0.6
1	M	M	100-165	±1.1
1	M	1	100-165	±1.35
1	1	0	100-165	±0.8
1	1	M	100-165	±0.9
1	1	1	Power Down	—

0 = connect to GND

M = unconnected (floating) has internal Pull up resistor to VDD and is considered as a 1 state

1 = connect directly to VDD

Pin Descriptions (MK1709S)

Pin Number	Pin Name	Pin Type	Pin Description
1	ICLK	Input	Connect to graphics input clock.
2	VDD	Power	Connect to +3.3 V.
3	GND	Power	Connect to ground.
4	CLK	Output	Spread spectrum clock output per table above.
5	LEE	Input	Low EMI enable. Turns on spread spectrum when high. Internal pull-up resistor.
6	S0	Input	Function select 0 input. Selects spread amount and direction per table above. Internal mid-level.
7	S1	Input	Function select 1 input. Selects spread amount and direction per table above. Internal mid-level.
8	S2	Input	Function select 2 input. Selects spread amount and direction per table above.

Pin Descriptions (MK1709AG)

Pin Number	Pin Name	Pin Type	Pin Description
1	GND	Power	Connect to ground.
2	CLK	Output	Spread spectrum clock output per table above.
3	LEE	Input	Low EMI enable. Turns on spread spectrum when high. Internal pull-up resistor.
4	S0	Input	Function select 0 input. Selects spread amount and direction per table above. Internal mid-level.
5	S1	Input	Function select 1 input. Selects spread amount and direction per table above. Internal mid-level.
6	S2	Input	Function select 2 input. Selects spread amount and direction per table above.
7	ICLK	Input	Connect to graphics input clock.
8	VDD	Power	Connect to +3.3 V.

External Components

The MK1709 requires a minimum number of external components for proper operation.

Decoupling Capacitor

A decoupling capacitor of 0.01 μ F must be connected between VDD and GND on pins 2 and 3 for the MK1709S, or pins 1 and 8 for the MK1709AG. Place the capacitor as close to these pins as possible. For optimum device performance, the decoupling capacitor should be mounted on the component side of the PCB. Avoid the use of vias in the decoupling circuit.

Series Termination Resistor

When the PCB trace between the clock output and the load is over 1 inch, series termination should be used. To series terminate a 50 Ω trace (a commonly used trace impedance), place a 33 Ω resistor in series with the clock line, as close to the clock output pin as possible. The nominal impedance of the clock output is 20 Ω .

Select Pin Operation

The S1, S0 select pins are 2-level, meaning they have three separate states to make the selections shown in the table on page 2.

PCB layout Recommendations

For optimum device performance and lowest output phase noise, the following guidelines should be observed.

- 1) The 0.01 μ F decoupling capacitor should be mounted on the component side of the board as close to the VDD pin as possible. No vias should be used between the decoupling capacitor and VDD pin. The PCB trace to VDD pin should be kept as short as possible, as should the PCB trace to the ground via.
- 2) Place a 33 Ω series termination resistor (if needed) close to the clock output to minimize EMI.
- 3) An optimum layout is one with all components on the same side of the board, minimizing vias through other signal layers. Other signal traces should be routed away from the MK1709. This includes signal traces just underneath the device, or on layers adjacent to the ground plane layer used by the device.

Absolute Maximum Ratings

Stresses above the ratings listed below can cause permanent damage to the MK1709. These ratings, which are standard values for ICS commercially rated parts, are stress ratings only. Functional operation of the device at these or any other conditions above those indicated in the operational sections of the specifications is not implied. Exposure to absolute maximum rating conditions for extended periods can affect product reliability. Electrical parameters are guaranteed only over the recommended operating temperature range. Typical values are at 25°C.

Item	Rating
Supply Voltage, VDD (referenced to GND)	5 V
All Inputs and Outputs (referenced to GND)	-0.5 V to VDD+0.5 V
Ambient Operating Temperature	0 to +85°C
Storage Temperature	-65 to +150°C
Soldering Temperature (maximum of 10 seconds)	260°C

Recommended Operation Conditions

Parameter	Min.	Typ.	Max.	Units
Ambient Operating Temperature	0		+85	°C
Power Supply Voltage (measured in respect to GND)	+3.135		+3.6	V

DC Electrical Characteristics

Unless stated otherwise, **VDD = 3.3 V**, Ambient Temperature 0 to +85°C

Parameter	Symbol	Conditions	Min.	Typ.	Max.	Units
Operating Voltage	VDD		3.135		3.465	V
Supply Current (MK1709S)	IDD	No load, at 3.3 V		20		mA
Supply Current (MK1709AG)	IDD	No load, 50M		13		μA
	IDD	No load, 150M		23		
Input High Voltage (ICLK)	V _{IH}		(VDD/2)+1	VDD/2		V
Input High Voltage (S1, S0)	V _{IH}		VDD-0.5			V
Input High Voltage (other inputs)	V _{IH}		2			V
Input Low Voltage (ICLK)	V _{IL}			VDD/2	(VDD/2)-1	V
Input Low Voltage	V _{IL}				0.5	V
Output High Voltage (CMOS)	V _{OH}	I _{OH} = -4mA	VDD-0.4			V
Output High Voltage	V _{OH}	I _{OH} = -12 mA	2.4			V
Output Low Voltage	V _{OL}	I _{OL} = 12 mA			0.4	V
Input Capacitance	C _{IN}	S0, S1, S2, LEE pins		7		pF

AC Electrical Characteristics (MK1709S)

Unless stated otherwise, VDD = 3.3 V, Ambient Temperature 0 to +85° C

Parameter	Symbol	Conditions	Min.	Typ.	Max.	Units
Input/Output Clock Frequency			80		167	MHz
Input Clock Duty Cycle		Time above VDD/2	20		80	%
Output Clock Duty Cycle		Time above 1.5 V	40	50	60	%
Output Clock Rise Time	t _{OR}	0.8 to 2.0V		1.5		ns
Output Clock Fall Time	t _{OF}	2.0 to 0.8V		1.5		ns
EMI Peak Frequency Reduction		3rd - 19th odd harmonics		7 to 14		dB

AC Electrical Characteristics (MK1709AG)

Unless stated otherwise, VDD = 3.3 V, Ambient Temperature 0 to +85° C

Parameter	Symbol	Conditions	Min.	Typ.	Max.	Units
Input/Output Clock Frequency			25		165	MHz
Input Clock Duty Cycle		Time above VDD/2	20		80	%
Output Clock Duty Cycle		Time above 1.5 V, 40 MHz - 100 MHz	40	50	55	%
		Time above 1.5 V, 100 MHz - 150 MHz		45		%
		Time above 1.5 V, >150 MHz		35		%
Output Clock Rise Time	t _{OR}	0.8 to 2.0V			1.5	ns
Output Clock Fall Time	t _{OF}	2.0 to 0.8V			1.5	ns
EMI Peak Frequency Reduction		3rd - 19th odd harmonics		7 to 14		dB

Spread Spectrum Modulation Rate

For 40 to 50 MHz selections, modulation rate = input frequency/1028; for 50 to 100 MHz selections, modulation rate = input frequency/2056; for 100 to 165 MHz selections, modulation rate = input frequency/4112.

Marking Diagrams

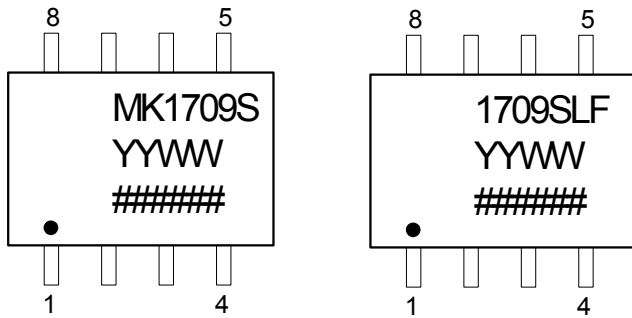

Marking for TSSOP package



Bottom marking:
Lot number and country of origin

Package Outline and Package Dimensions (8-pin SOIC, 150 Mil. Body)

Package dimensions are kept current with JEDEC Publication No. 95

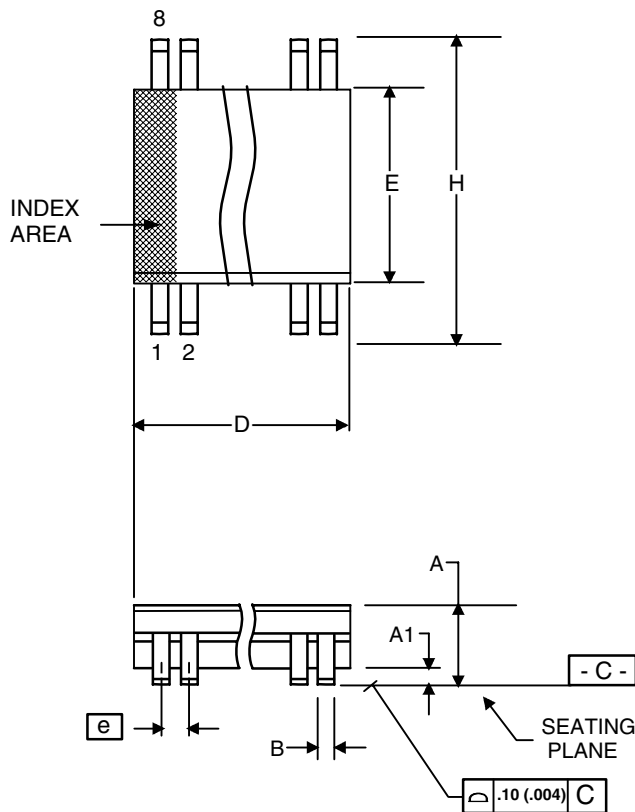

Symbol	Millimeters		Inches	
	Min	Max	Min	Max
A	1.35	1.75	.0532	.0688
A1	0.10	0.25	.0040	.0098
B	0.33	0.51	.013	.020
C	0.19	0.25	.0075	.0098
D	4.80	5.00	.1890	.1968
E	3.80	4.00	.1497	.1574
e	1.27 BASIC		0.050 BASIC	
H	5.80	6.20	.2284	.2440
h	0.25	0.50	.010	.020
L	0.40	1.27	.016	.050
α	0°	8°	0°	8°

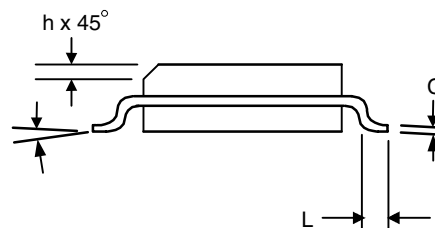

Package Outline and Package Dimensions (8-pin TSSOP, 173 Mil. Body)

Package dimensions are kept current with JEDEC Publication No. 95

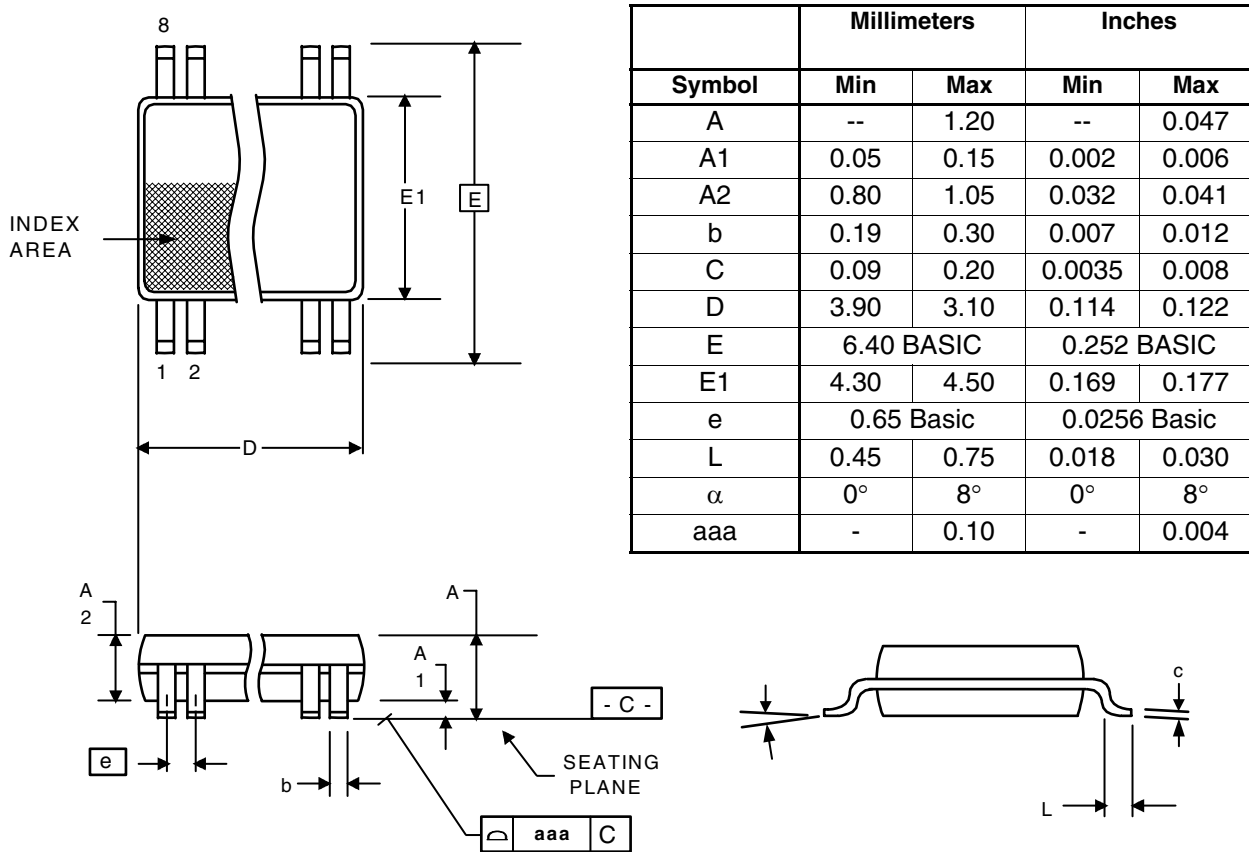

Ordering Information

Part / Order Number	Marking	Shipping Packaging	Package	Temperature
MK1709S	(see page 7)	Tubes	8-pin SOIC	0 to +85° C
MK1709STR		Tape and Reel	8-pin SOIC	0 to +85° C
MK1709SLF		Tubes	8-pin SOIC	0 to +85° C
MK1709SLFTR		Tape and Reel	8-pin SOIC	0 to +85° C
MK1709AG		Tubes	8-pin TSSOP	0 to +85° C
MK1709AGTR		Tape and Reel	8-pin TSSOP	0 to +85° C
MK1709AGLF		Tubes	8-pin TSSOP	0 to +85° C
MK1709AGLFTR		Tape and Reel	8-pin TSSOP	0 to +85° C

Parts that are ordered with a "LF" suffix to the part number are the Pb-Free configuration and are RoHS compliant.

While the information presented herein has been checked for both accuracy and reliability, Integrated Circuit Systems (ICS) assumes no responsibility for either its use or for the infringement of any patents or other rights of third parties, which would result from its use. No other circuits, patents, or licenses are implied. This product is intended for use in normal commercial applications. Any other applications such as those requiring extended temperature range, high reliability, or other extraordinary environmental requirements are not recommended without additional processing by ICS. ICS reserves the right to change any circuitry or specifications without notice. ICS does not authorize or warrant any ICS product for use in life support devices or critical medical instruments.

Innovate with IDT and accelerate your future networks. Contact:

www.IDT.com

For Sales

800-345-7015
408-284-8200
Fax: 408-284-2775

For Tech Support

<product line email>
<product line phone>

Corporate Headquarters

Integrated Device Technology, Inc.
6024 Silver Creek Valley Road
San Jose, CA 95138
United States
800 345 7015
+408 284 8200 (outside U.S.)

Asia Pacific and Japan

Integrated Device Technology
Singapore (1997) Pte. Ltd.
Reg. No. 199707558G
435 Orchard Road
#20-03 Wisma Atria
Singapore 238877
+65 6 887 5505

Europe

IDT Europe, Limited
Prime House
Barnett Wood Lane
Leatherhead, Surrey
United Kingdom KT22 7DE
+44 1372 363 339



www.IDT.com