

# DATA SHEET

For a complete data sheet, please also download:

- The IC04 LOCMOS HE4000B Logic Family Specifications HEF, HEC
- The IC04 LOCMOS HE4000B Logic Package Outlines/Information HEF, HEC

## **HEF4002B** **gates** Dual 4-input NOR gate

Product specification  
File under Integrated Circuits, IC04

January 1995

# Dual 4-input NOR gate

# HEF4002B gates

### DESCRIPTION

The HEF4002B provides the positive dual 4-input NOR function. The outputs are fully buffered for highest noise immunity and pattern insensitivity of output impedance.

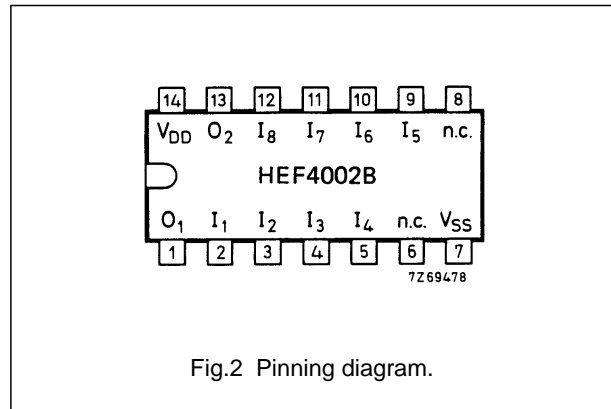
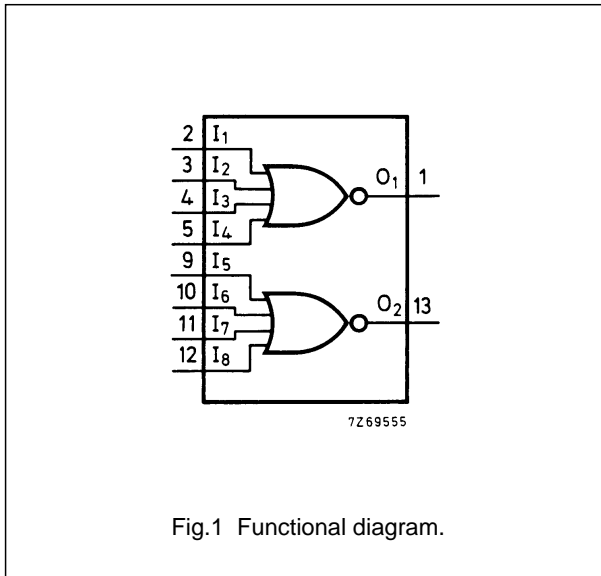

- HEF4002BP(N): 14-lead DIL; plastic (SOT27-1)
  - HEF4002BD(F): 14-lead DIL; ceramic (cerdip) (SOT73)
  - HEF4002BT(D): 14-lead SO; plastic (SOT108-1)
- ( ): Package Designator North America

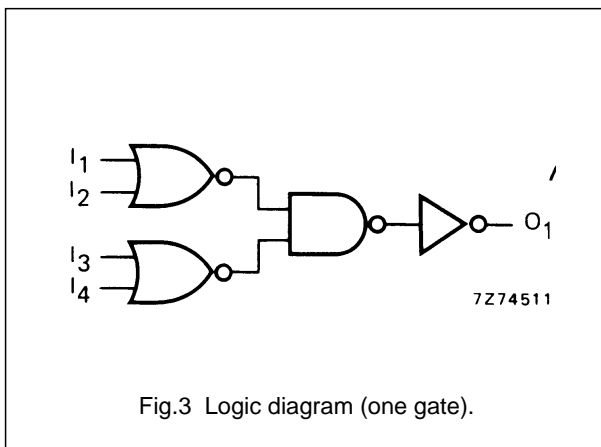

### FAMILY DATA, I<sub>DD</sub> LIMITS category GATES

See Family Specifications

## Dual 4-input NOR gate

HEF4002B  
gates**AC CHARACTERISTICS**

$V_{SS} = 0$  V;  $T_{amb} = 25$  °C;  $C_L = 50$  pF; input transition times  $\leq 20$  ns

	$V_{DD}$ V	SYMBOL	TYP.	MAX.		TYPICAL EXTRAPOLATION FORMULA
Propagation delays $I_n \rightarrow O_n$	5	$t_{PHL}; t_{PLH}$	60	120	ns	$33 \text{ ns} + (0,55 \text{ ns/pF}) C_L$
	10		25	50	ns	$14 \text{ ns} + (0,23 \text{ ns/pF}) C_L$
	15		20	40	ns	$12 \text{ ns} + (0,16 \text{ ns/pF}) C_L$
Output transition times HIGH to LOW	5	$t_{THL}$	60	120	ns	$10 \text{ ns} + (1,0 \text{ ns/pF}) C_L$
	10		30	60	ns	$9 \text{ ns} + (0,42 \text{ ns/pF}) C_L$
	15		20	40	ns	$6 \text{ ns} + (0,28 \text{ ns/pF}) C_L$
LOW to HIGH	5	$t_{TLH}$	60	120	ns	$10 \text{ ns} + (1,0 \text{ ns/pF}) C_L$
	10		30	60	ns	$9 \text{ ns} + (0,42 \text{ ns/pF}) C_L$
	15		20	40	ns	$6 \text{ ns} + (0,28 \text{ ns/pF}) C_L$

	$V_{DD}$ V	TYPICAL FORMULA FOR P ( $\mu$ W)	
Dynamic power dissipation per package (P)	5	$1050 f_i + \sum (f_o C_L) \times V_{DD}^2$	where $f_i$ = input freq. (MHz) $f_o$ = output freq. (MHz) $C_L$ = load capacitance (pF) $\sum (f_o C_L)$ = sum of outputs $V_{DD}$ = supply voltage (V)
	10	$4300 f_i + \sum (f_o C_L) \times V_{DD}^2$	
	15	$11\,700 f_i + \sum (f_o C_L) \times V_{DD}^2$	