

DATA SHEET

For a complete data sheet, please also download:

- The IC06 74HC/HCT/HCU/HCMOS Logic Family Specifications
- The IC06 74HC/HCT/HCU/HCMOS Logic Package Information
- The IC06 74HC/HCT/HCU/HCMOS Logic Package Outlines

74HC/HCT423

**Dual retriggerable monostable
multivibrator with reset**

Product specification
Supersedes data of December 1990
File under Integrated Circuits, IC06

1998 Jul 08

Dual retriggerable monostable multivibrator with reset

74HC/HCT423

FEATURES

- DC triggered from active HIGH or active LOW inputs
- Retriggerable for very long pulses up to 100% duty factor
- Direct reset terminates output pulse
- Schmitt-trigger action on all inputs except for the reset input
- Output capability: standard (except for nR_{EXT}/C_{EXT})
- I_{CC} category: MSI

GENERAL DESCRIPTION

The 74HC/HCT423 are high-speed Si-gate CMOS devices and are pin compatible with low power Schottky TTL (LSTTL). They are specified in compliance with JEDEC standard no. 7A.

The 74HC/HCT423 are dual retriggerable monostable multivibrators with output pulse width control by two methods. The basic pulse time is programmed by selection of an external resistor (R_{EXT}) and capacitor

(C_{EXT}). The external resistor and capacitor are normally connected as shown in Fig.6.

Once triggered, the basic output pulse width may be extended by retriggering the gated active LOW-going edge input (n \bar{A}) or the active HIGH-going edge input (nB). By repeating this process, the output pulse period (nQ = HIGH, n \bar{Q} = LOW) can be made as long as desired. When n \bar{R}_D is LOW, it forces the nQ output LOW, the n \bar{Q} output HIGH and also inhibits the triggering.

Figures 7 and 8 illustrate pulse control by reset. The basic output pulse width is essentially determined by the values of the external timing components R_{EXT} and C_{EXT}.

For pulse widths, when C_{EXT} < 10 000 pF, see Fig.9. When C_{EXT} > 10 000 pF, the typical output pulse width is defined as:

$$t_W = 0.45 \times R_{EXT} \times C_{EXT} \text{ (typ.)},$$

where, t_W = pulse width in ns;

R_{EXT} = external resistor in k Ω ;

C_{EXT} = external capacitor in pF.

Schmitt-trigger action in the n \bar{A} and nB inputs, makes the circuit highly tolerant to slower input rise and fall times.

The "423" is identical to the "123" but cannot be triggered via the reset input.

QUICK REFERENCE DATA

GND = 0 V; T_{amb} = 25 °C; t_r = t_f = 6 ns

SYMBOL	PARAMETER	CONDITIONS	TYPICAL		UNIT
			HC	HCT	
t _{PHL} / t _{PLH}	propagation delay n \bar{A} , nB to nQ, n \bar{Q}	C _L = 15 pF; V _{CC} = 5 V; R _{EXT} = 5 k Ω ; C _{EXT} = 0 pF	25	26	ns
	n \bar{R}_D to nQ, n \bar{Q}		20	22	ns
C _I	input capacitance		3.5	3.5	pF
t _W	minimum output pulse width nQ, n \bar{Q}	notes 1 and 2	75	75	ns

Notes

1. C_{PD} is used to determine the dynamic power dissipation (P_D in μ W):

$$P_D = C_{PD} \times V_{CC}^2 \times f_i + \sum (C_L \times V_{CC}^2 \times f_o) + 0.75 \times C_{EXT} \times V_{CC}^2 \times f_o + D \times 16 \times V_{CC} \text{ where:}$$

f_i = input frequency in MHz

f_o = output frequency in MHz

D = duty factor in %

$\sum (C_L \times V_{CC}^2 \times f_o)$ = sum of outputs

C_L = output load capacitance in pF

V_{CC} = supply voltage in V

C_{EXT} = timing capacitance in pF

2. For HC the condition is V_I = GND to V_{CC}
For HCT the condition is V_I = GND to V_{CC} - 1.5 V

Dual retriggerable monostable multivibrator with reset

74HC/HCT423

ORDERING INFORMATION

TYPE NUMBER	PACKAGE		
	NAME	DESCRIPTION	VERSION
74HC423N; 74HCT423N	DIP16	plastic dual in-line package; 16 leads (300 mil); long body	SOT38-1
74HC423D; 74HCT423D	SO16	plastic small outline package; 16 leads; body width 3.9 mm; low stand-off height	SOT109-1

PIN DESCRIPTION

PIN NO.	SYMBOL	NAME AND FUNCTION
1, 9	$1\bar{A}, 2\bar{A}$	trigger inputs (negative-edge triggered)
2, 10	1B, 2B	trigger inputs (positive-edge triggered)
3, 11	$1\bar{R}_D, 2\bar{R}_D$	direct reset action (active LOW)
4, 12	$1\bar{Q}, 2\bar{Q}$	outputs (active LOW)
7	$2R_{EXT}/C_{EXT}$	external resistor/capacitor connection
8	GND	ground (0 V)
13, 5	1Q, 2Q	outputs (active HIGH)
14, 6	$1C_{EXT}, 2C_{EXT}$	external capacitor connection
15	$1R_{EXT}/C_{EXT}$	external resistor/capacitor connection
16	V_{CC}	positive supply voltage

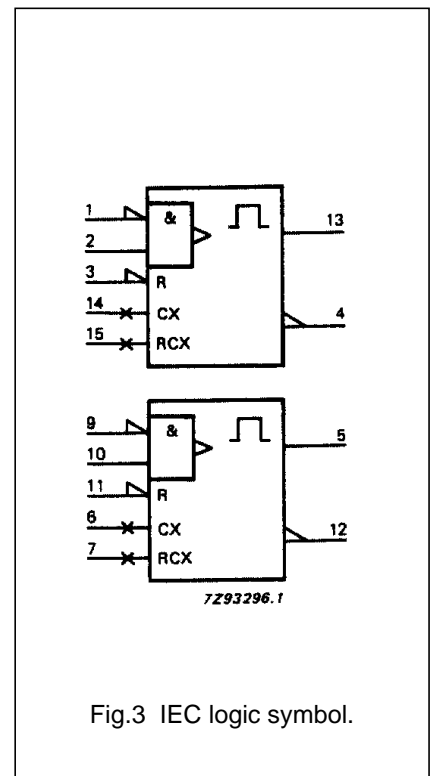
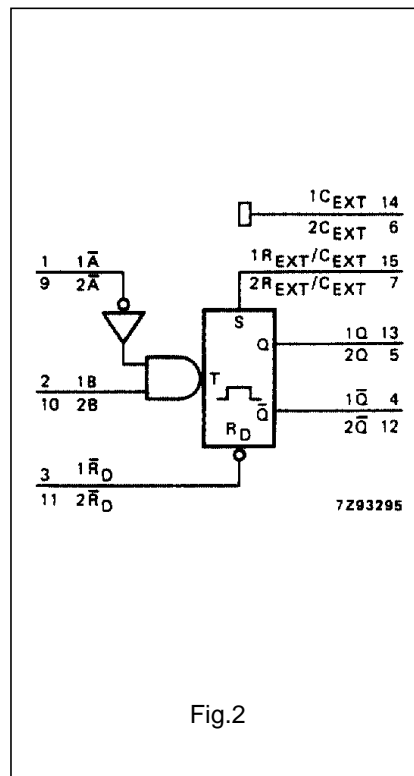
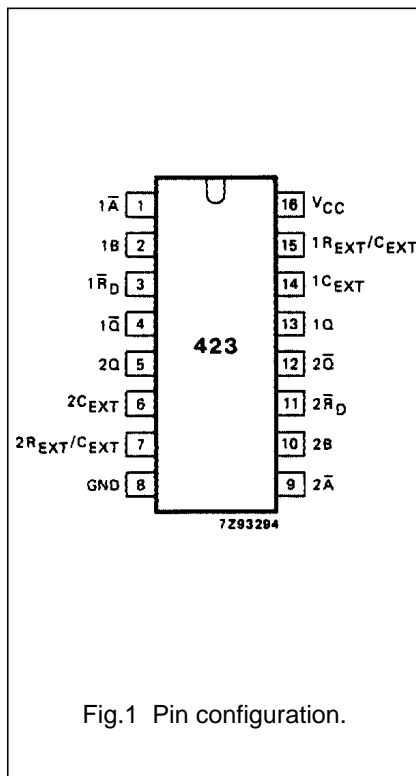

Dual retriggerable monostable
multivibrator with reset

74HC/HCT423

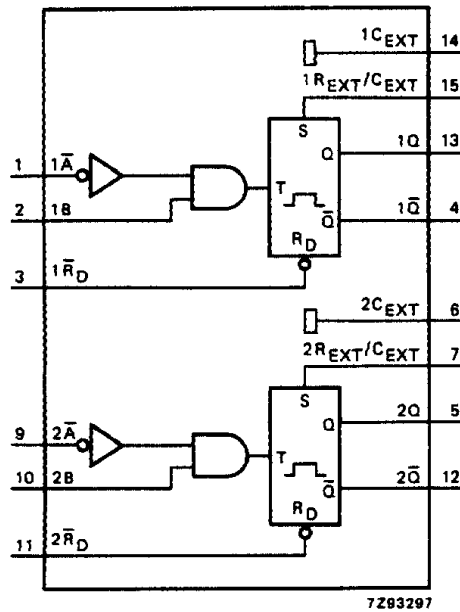

Fig.4 Functional diagram.

FUNCTION TABLE

INPUTS			OUTPUTS	
$n\bar{R}_D$	$n\bar{A}$	nB	nQ	$n\bar{Q}$
L	X	X	L	H
X	H	X	L ⁽²⁾	H ⁽²⁾
X	X	L	L ⁽²⁾	H ⁽²⁾
H	L	↑		
H	↓	H		

Notes

- H = HIGH voltage level
 L = LOW voltage level
 X = don't care
 ↑ = LOW-to-HIGH transition
 ↓ = HIGH-to-LOW transition

= one HIGH level output pulse

= one LOW level output pulse
- If the monostable was triggered before this condition was established, the pulse will continue as programmed.

Dual retriggerable monostable
multivibrator with reset

74HC/HCT423

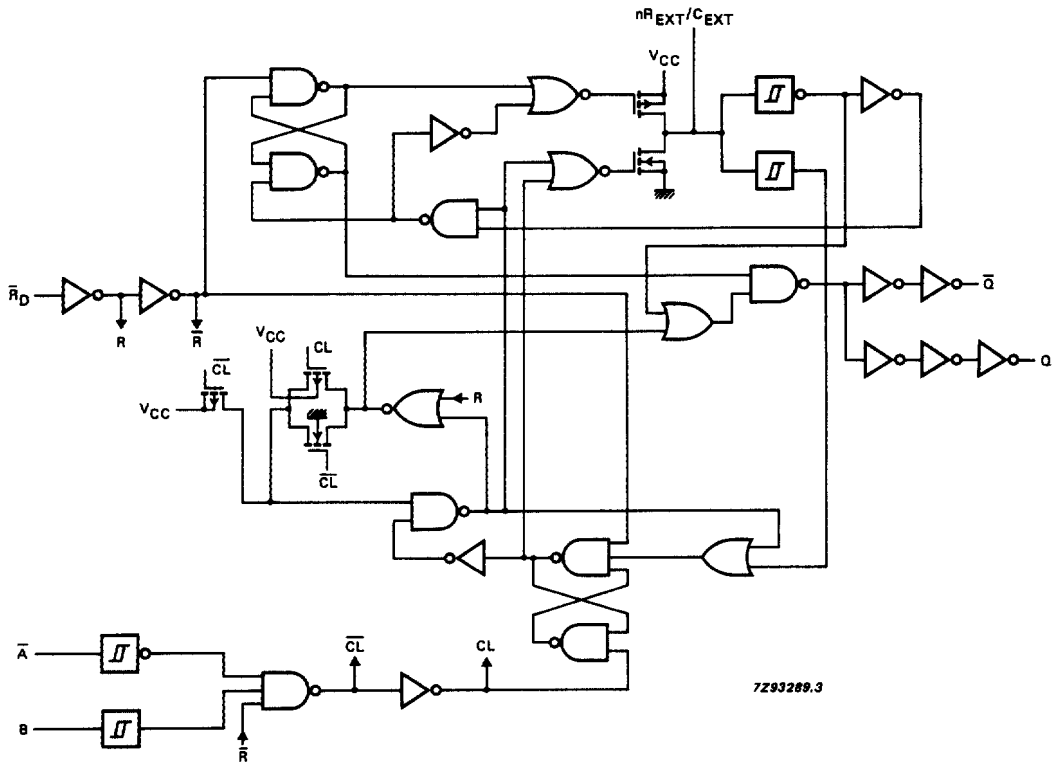

It is recommended to ground pins 6 ($2C_{EXT}$) and 14 ($1C_{EXT}$) externally to pin 8 (GND).

Fig.5 Logic diagram.

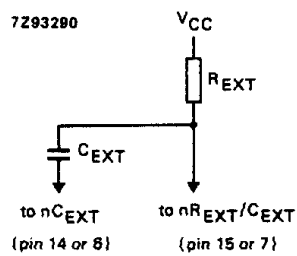

Fig.6 Timing component connections.

Dual retriggerable monostable multivibrator with reset

74HC/HCT423

DC CHARACTERISTICS FOR 74HC

For the DC characteristics see *"74HC/HCT/HCU/HCMOS Logic Family Specifications"*.

Output capability: standard (except for nR_{EXT}/C_{EXT})

I_{CC} category: MSI

AC CHARACTERISTICS FOR 74HC

$GND = 0 V$; $t_r = t_f = 6 ns$; $C_L = 50 pF$

SYMBOL	PARAMETER	$T_{amb} (°C)$							UNIT	TEST CONDITIONS	
		74HC								V_{CC} (V)	WAVEFORMS/ NOTES
		+25			-40 to +85		-40 to +125				
		min.	typ.	max.	min.	max.	min.	max.			
t_{PHL}/t_{PLH}	propagation delay $n\bar{A}$, nB to $n\bar{Q}$, nQ		80 29 23	255 51 43		320 64 54		385 77 65	ns	2.0 4.5 6.0	$C_{EXT} = 0 pF$; $R_{EXT} = 5 k\Omega$
t_{PHL}/t_{PLH}	propagation delay $n\bar{R}_D$ to nQ , $n\bar{Q}$		66 24 19	215 43 37		270 54 46		325 65 55	ns	2.0 4.5 6.0	$C_{EXT} = 0 pF$; $R_{EXT} = 5 k\Omega$
t_{THL}/t_{TLH}	output transition time		19 7 6	75 15 13		95 19 16		110 22 19	ns	2.0 4.5 6.0	
t_w	trigger pulse width $n\bar{A} = LOW$	100 20 17	11 4 3		125 25 21		150 30 26		ns	2.0 4.5 6.0	Fig.7
t_w	trigger pulse width $nB = HIGH$	100 20 17	17 6 5		125 25 21		150 30 26		ns	2.0 4.5 6.0	Fig.7
t_w	reset pulse width $n\bar{R}_D = LOW$	100 20 17	14 5 4		125 25 21		150 30 26		ns	2.0 4.5 6.0	Fig.8
t_w	output pulse width $nQ = HIGH$ $n\bar{Q} = LOW$		450		–		–		μs	5.0	$C_{EXT} = 100 nF$; $R_{EXT} = 10 k\Omega$; Figs 7 and 8
t_w	output pulse width $nQ = HIGH$ $n\bar{Q} = LOW$		75		–		–		ns	5.0	$C_{EXT} = 0 pF$; $R_{EXT} = 5 k\Omega$; note 1; Figs 7 and 8
t_{rt}	retrigger time $n\bar{A}$, nB		110		–		–		ns	5.0	$C_{EXT} = 0 pF$; $R_{EXT} = 5 k\Omega$; note 2; Fig. 7
R_{EXT}	external timing resistor	10 2		1000 1000	–		–		$k\Omega$	2.0 5.0	Fig.9
C_{EXT}	external timing capacitor	no limits							pF	5.0	Fig.9; note 3

Dual retriggerable monostable multivibrator with reset

74HC/HCT423

DC CHARACTERISTICS FOR 74HCT

For the DC characteristics see *"74HC/HCT/HCU/HCMOS Logic Family Specifications"*.

Output capability: standard (except for nR_{EXT}/C_{EXT})

I_{CC} category: MSI

Note to HCT types

The value of additional quiescent supply current (ΔI_{CC}) for a unit load of 1 is given in the family specifications. To determine ΔI_{CC} per input, multiply this value by the unit load coefficient shown in the table below.

INPUT	UNIT LOAD COEFFICIENT
$n\bar{A}$, nB	0.35
$n\bar{R}_D$	0.50

AC CHARACTERISTICS FOR 74HCT

$GND = 0\text{ V}$; $t_r = t_f = 6\text{ ns}$; $C_L = 50\text{ pF}$

SYMBOL	PARAMETER	$T_{amb} (\text{°C})$							UNIT	TEST CONDITIONS	
		74HCT								V_{CC} (V)	WAVEFORMS/ NOTES
		+25			-40 to +85		-40 to +125				
		min.	typ.	max.	min.	max.	min.	max.			
t_{PHL}/t_{PLH}	propagation delay nA , nB to nQ , nQ		30	51		64		77	ns	4.5	$C_{EXT} = 0\text{ pF}$; $R_{EXT} = 5\text{ k}\Omega$
t_{PHL}/t_{PLH}	propagation delay $n\bar{R}_D$ to nQ , nQ		26	48		60		72	ns	4.5	$C_{EXT} = 0\text{ pF}$; $R_{EXT} = 5\text{ k}\Omega$
t_{THL}/t_{TLH}	output transition time		7	15		19		22	ns	4.5	
t_W	trigger pulse width $nA = \text{LOW}$	20	5		25		30		ns	4.5	Fig.7
t_W	trigger pulse width $nB = \text{HIGH}$	20	5		25		30		ns	4.5	Fig.7
t_W	reset pulse width $n\bar{R}_D = \text{LOW}$	20	7		25		30		ns	4.5	Fig.8
t_W	output pulse width $nQ = \text{HIGH}$ $nQ = \text{LOW}$		450		–		–		μs	5.0	$C_{EXT} = 100\text{ nF}$; $R_{EXT} = 10\text{ k}\Omega$; Figs 7 and 8
t_W	output pulse width $nQ = \text{HIGH}$ $nQ = \text{LOW}$		75		–		–		ns	5.0	$C_{EXT} = 0\text{ pF}$; $R_{EXT} = 5\text{ k}\Omega$; note 1; Figs 7 and 8
t_{rt}	retrigger time nA , nB		110		–		–		ns	5.0	$C_{EXT} = 0\text{ pF}$; $R_{EXT} = 5\text{ k}\Omega$; note 2; Fig.7
R_{EXT}	external timing resistor	2		1000	–		–		$\text{k}\Omega$	5.0	Fig.9
C_{EXT}	external timing capacitor	no limits							pF	5.0	Fig.9; note 3

Dual retriggerable monostable multivibrator with reset

74HC/HCT423

Notes

- For other R_{EXT} and C_{EXT} combinations see Fig.9.
 If $C_{EXT} > 10$ pF, the next formula is valid:
 $t_W = K \times R_{EXT} \times C_{EXT}$ (typ.)
 where: t_W = output pulse width in ns;
 R_{EXT} = external resistor in k Ω ; C_{EXT} = external capacitor in pF;
 K = constant = 0.45 for $V_{CC} = 5.0$ V and 0.55 for $V_{CC} = 2.0$ V.
 The inherent test jig and pin capacitance at pins 15 and 7 (nR_{EXT}/C_{EXT}) is approximately 7 pF.
- The time to retrigger the monostable multivibrator depends on the values of R_{EXT} and C_{EXT} .
 The output pulse width will only be extended when the time between the active-going edges of the trigger input pulses meets the minimum retrigger time.
 If $C_{EXT} > 10$ pF, the next formula (at $V_{CC} = 5.0$ V) for the set-up time of a retrigger pulse is valid:
 $t_{rt} = 30 + 0.19 \times R_{EXT} \times C_{EXT}^{0.9} + 13 \times R_{EXT}^{1.05}$ (typ.)
 where, t_{rt} = retrigger time in ns;
 C_{EXT} = external capacitor in pF;
 R_{EXT} = external resistor in k Ω .
 The inherent test jig and pin capacitance at pins 15 and 7 (nR_{EXT}/C_{EXT}) is 7 pF.
- When the device is powered-up, initiate the device via a reset pulse, when $C_{EXT} < 50$ pF.

AC WAVEFORMS

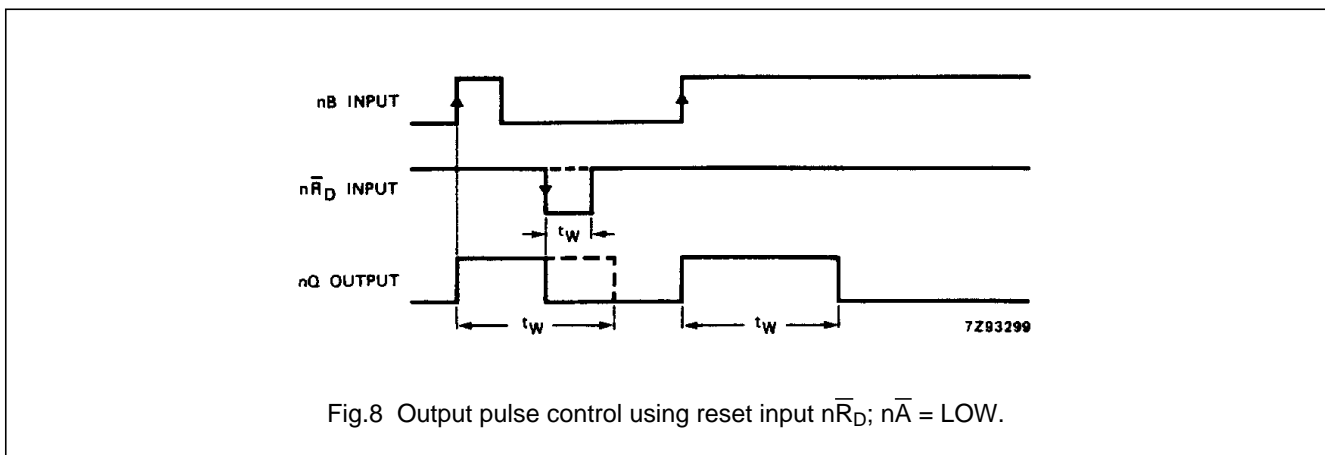
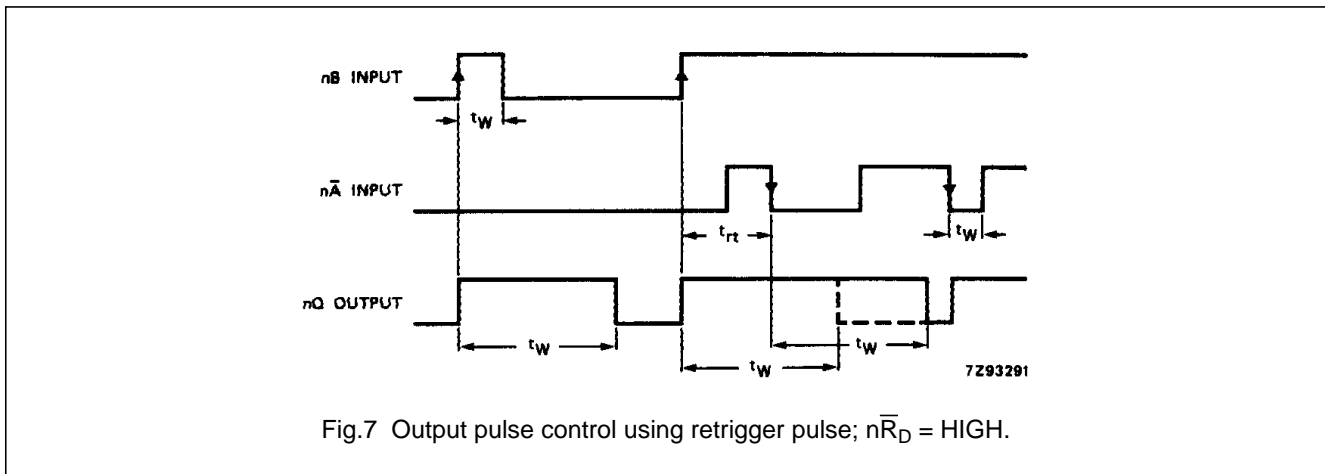

Dual retriggerable monostable
multivibrator with reset

74HC/HCT423

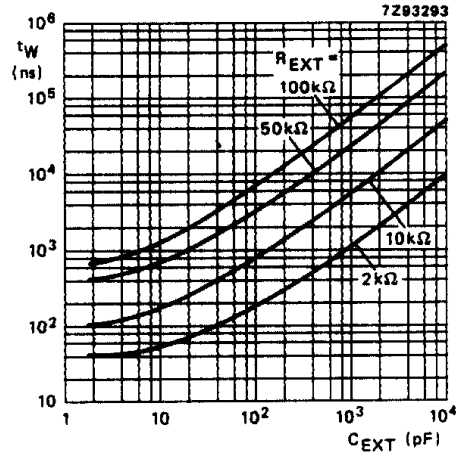

Fig.9 Typical output pulse width as a function of the external capacitor values at $V_{CC} = 5.0$ V and $T_{amb} = 25$ °C.

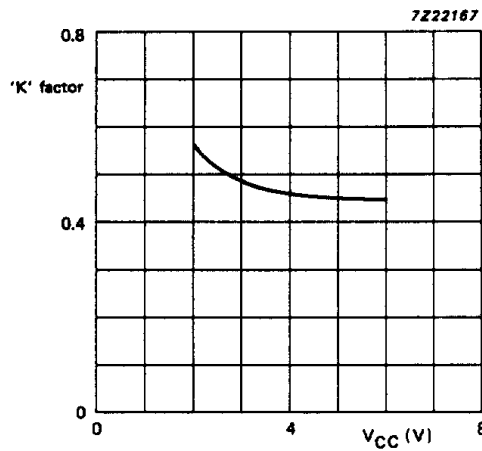

Fig.10 Typical 'K' factor; external capacitance = 10 nF, external resistance = 10 k Ω to 100 k Ω and $T_{amb} = 25$ °C.

Dual retriggerable monostable multivibrator with reset

74HC/HCT423

APPLICATION INFORMATION

Power-up considerations

When the monostable is powered-up it may produce an output pulse, with a pulse width defined by the values of R_X and C_X , this output pulse can be eliminated using the circuit shown in Fig.11.

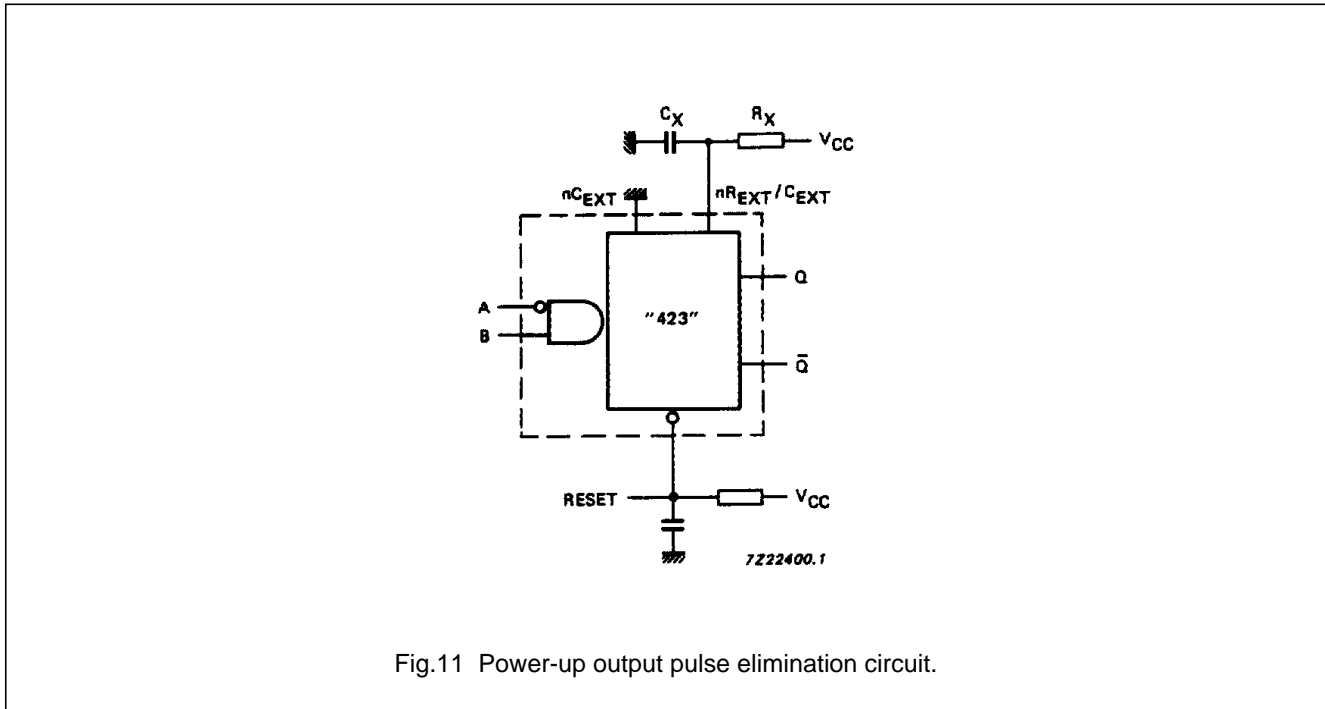

Power-down considerations

A large capacitor (C_X) may cause problems when powering-down the monostable due to the energy stored in this capacitor. When a system containing this device is powered-down or a rapid decrease of V_{CC} to zero occurs, the monostable may sustain damage, due to the capacitor discharging through the input protection diodes. To avoid this possibility, use a damping diode (D_X) preferably a germanium or Schottky-type diode able to withstand large current surges and connect as shown in Fig.12.

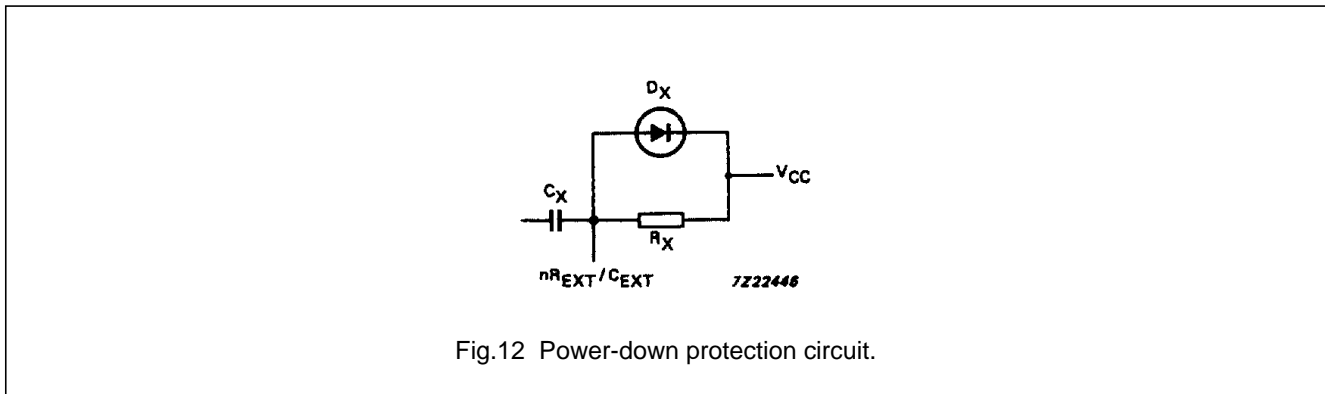

Dual retriggerable monostable multivibrator with reset

74HC/HCT423

PACKAGE OUTLINES

DIP16: plastic dual in-line package; 16 leads (300 mil); long body

SOT38-1

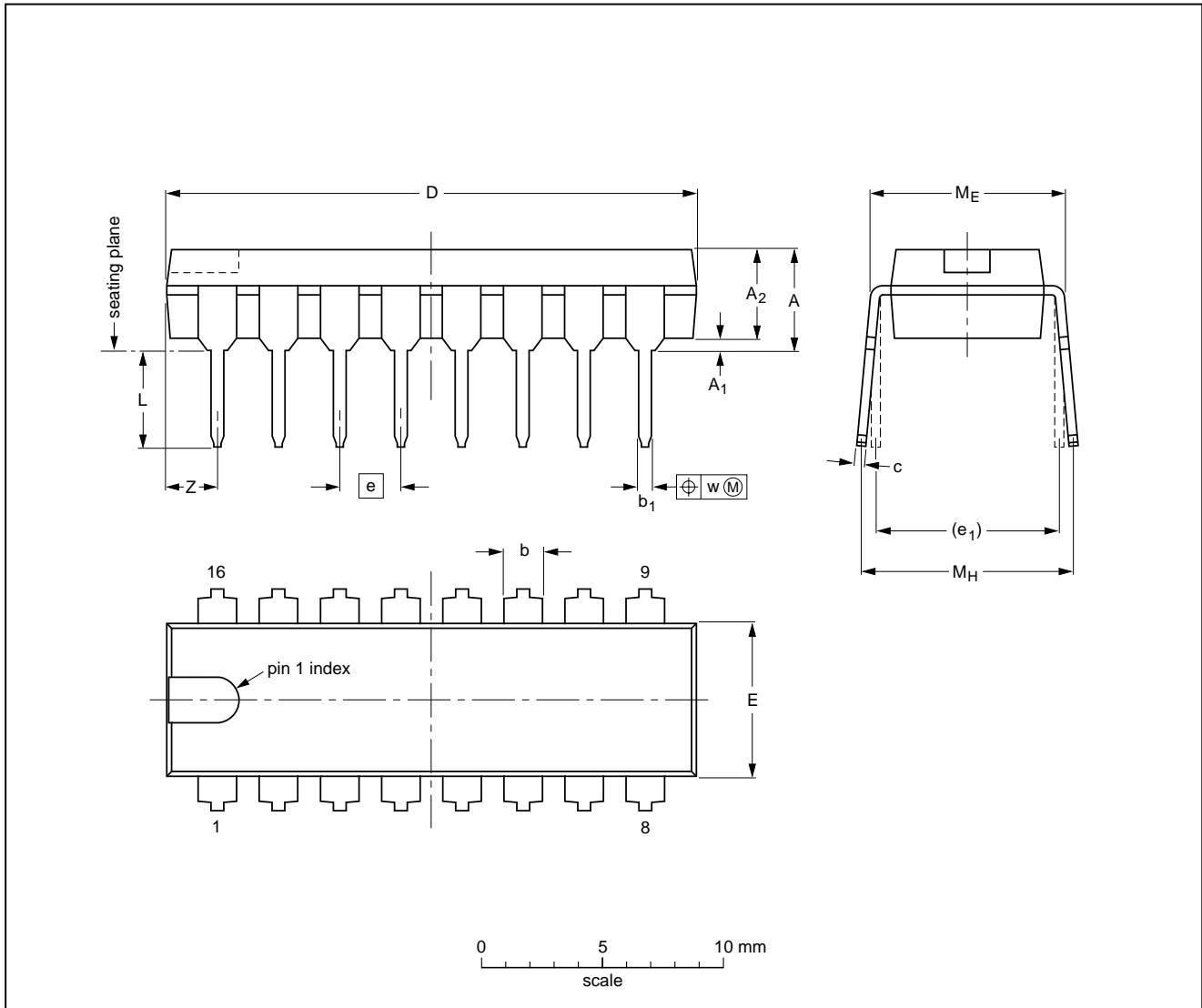

DIMENSIONS (inch dimensions are derived from the original mm dimensions)

UNIT	A max.	A ₁ min.	A ₂ max.	b	b ₁	c	D ⁽¹⁾	E ⁽¹⁾	e	e ₁	L	M _E	M _H	w	Z ⁽¹⁾ max.
mm	4.7	0.51	3.7	1.40 1.14	0.53 0.38	0.32 0.23	21.8 21.4	6.48 6.20	2.54	7.62	3.9 3.4	8.25 7.80	9.5 8.3	0.254	2.2
inches	0.19	0.020	0.15	0.055 0.045	0.021 0.015	0.013 0.009	0.86 0.84	0.26 0.24	0.10	0.30	0.15 0.13	0.32 0.31	0.37 0.33	0.01	0.087

Note

1. Plastic or metal protrusions of 0.25 mm maximum per side are not included.

OUTLINE VERSION	REFERENCES				EUROPEAN PROJECTION	ISSUE DATE
	IEC	JEDEC	EIAJ			
SOT38-1	050G09	MO-001AE				92-10-02 95-01-19

Dual retriggerable monostable
multivibrator with reset

74HC/HCT423

SO16: plastic small outline package; 16 leads; body width 3.9 mm

SOT109-1

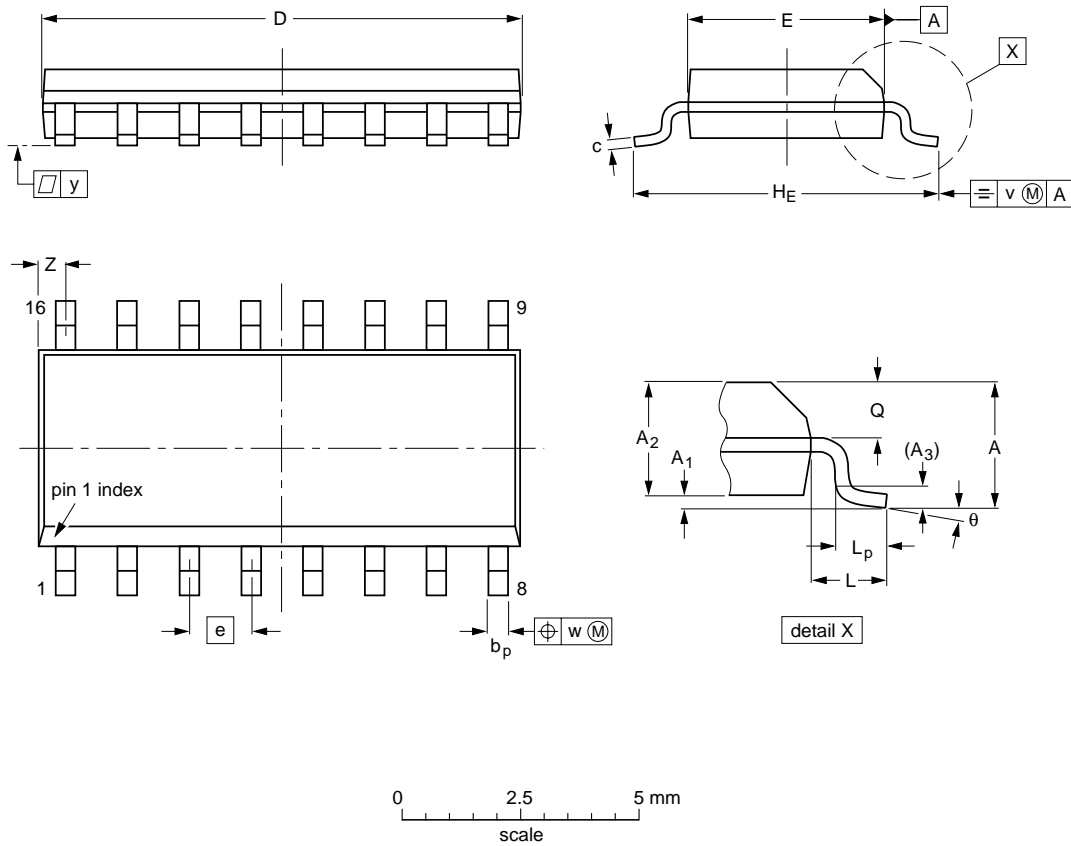

DIMENSIONS (inch dimensions are derived from the original mm dimensions)

UNIT	A max.	A ₁	A ₂	A ₃	b _p	c	D ⁽¹⁾	E ⁽¹⁾	e	H _E	L	L _p	Q	v	w	y	Z ⁽¹⁾	θ
mm	1.75	0.25 0.10	1.45 1.25	0.25	0.49 0.36	0.25 0.19	10.0 9.8	4.0 3.8	1.27	6.2 5.8	1.05	1.0 0.4	0.7 0.6	0.25	0.25	0.1	0.7 0.3	8° 0°
inches	0.069	0.010 0.004	0.057 0.049	0.01	0.019 0.014	0.0100 0.0075	0.39 0.38	0.16 0.15	0.050	0.244 0.228	0.041	0.039 0.016	0.028 0.020	0.01	0.01	0.004	0.028 0.012	

Note

1. Plastic or metal protrusions of 0.15 mm maximum per side are not included.

OUTLINE VERSION	REFERENCES				EUROPEAN PROJECTION	ISSUE DATE
	IEC	JEDEC	EIAJ			
SOT109-1	076E07S	MS-012AC				95-01-23 97-05-22

Dual retriggerable monostable multivibrator with reset

74HC/HCT423

SOLDERING

Introduction

There is no soldering method that is ideal for all IC packages. Wave soldering is often preferred when through-hole and surface mounted components are mixed on one printed-circuit board. However, wave soldering is not always suitable for surface mounted ICs, or for printed-circuits with high population densities. In these situations reflow soldering is often used.

This text gives a very brief insight to a complex technology. A more in-depth account of soldering ICs can be found in our *"Data Handbook IC26; Integrated Circuit Packages"* (order code 9398 652 90011).

DIP

SOLDERING BY DIPPING OR BY WAVE

The maximum permissible temperature of the solder is 260 °C; solder at this temperature must not be in contact with the joint for more than 5 seconds. The total contact time of successive solder waves must not exceed 5 seconds.

The device may be mounted up to the seating plane, but the temperature of the plastic body must not exceed the specified maximum storage temperature ($T_{stg\ max}$). If the printed-circuit board has been pre-heated, forced cooling may be necessary immediately after soldering to keep the temperature within the permissible limit.

REPAIRING SOLDERED JOINTS

Apply a low voltage soldering iron (less than 24 V) to the lead(s) of the package, below the seating plane or not more than 2 mm above it. If the temperature of the soldering iron bit is less than 300 °C it may remain in contact for up to 10 seconds. If the bit temperature is between 300 and 400 °C, contact may be up to 5 seconds.

SO

REFLOW SOLDERING

Reflow soldering techniques are suitable for all SO packages.

Reflow soldering requires solder paste (a suspension of fine solder particles, flux and binding agent) to be applied to the printed-circuit board by screen printing, stencilling or pressure-syringe dispensing before package placement.

Several techniques exist for reflowing; for example, thermal conduction by heated belt. Dwell times vary between 50 and 300 seconds depending on heating method. Typical reflow temperatures range from 215 to 250 °C.

Preheating is necessary to dry the paste and evaporate the binding agent. Preheating duration: 45 minutes at 45 °C.

WAVE SOLDERING

Wave soldering techniques can be used for all SO packages if the following conditions are observed:

- A double-wave (a turbulent wave with high upward pressure followed by a smooth laminar wave) soldering technique should be used.
- The longitudinal axis of the package footprint must be parallel to the solder flow.
- The package footprint must incorporate solder thieves at the downstream end.

During placement and before soldering, the package must be fixed with a droplet of adhesive. The adhesive can be applied by screen printing, pin transfer or syringe dispensing. The package can be soldered after the adhesive is cured.

Maximum permissible solder temperature is 260 °C, and maximum duration of package immersion in solder is 10 seconds, if cooled to less than 150 °C within 6 seconds. Typical dwell time is 4 seconds at 250 °C.

A mildly-activated flux will eliminate the need for removal of corrosive residues in most applications.

REPAIRING SOLDERED JOINTS

Fix the component by first soldering two diagonally-opposite end leads. Use only a low voltage soldering iron (less than 24 V) applied to the flat part of the lead. Contact time must be limited to 10 seconds at up to 300 °C. When using a dedicated tool, all other leads can be soldered in one operation within 2 to 5 seconds between 270 and 320 °C.

Dual retriggerable monostable multivibrator with reset

74HC/HCT423

DEFINITIONS

Data sheet status	
Objective specification	This data sheet contains target or goal specifications for product development.
Preliminary specification	This data sheet contains preliminary data; supplementary data may be published later.
Product specification	This data sheet contains final product specifications.
Limiting values	
Limiting values given are in accordance with the Absolute Maximum Rating System (IEC 134). Stress above one or more of the limiting values may cause permanent damage to the device. These are stress ratings only and operation of the device at these or at any other conditions above those given in the Characteristics sections of the specification is not implied. Exposure to limiting values for extended periods may affect device reliability.	
Application information	
Where application information is given, it is advisory and does not form part of the specification.	

LIFE SUPPORT APPLICATIONS

These products are not designed for use in life support appliances, devices, or systems where malfunction of these products can reasonably be expected to result in personal injury. Philips customers using or selling these products for use in such applications do so at their own risk and agree to fully indemnify Philips for any damages resulting from such improper use or sale.