

MM74C925 • MM74C926 • MM74C927 • MM74C928 4-Digit Counters with Multiplexed 7-Segment Output Drivers

General Description

The MM74C925, MM74C926, MM74C927 and MM74C928 CMOS counters consist of a 4-digit counter, an internal output latch, NPN output sourcing drivers for a 7-segment display, and an internal multiplexing circuitry with four multiplexing outputs. The multiplexing circuit has its own free-running oscillator, and requires no external clock. The counters advance on negative edge of clock. A HIGH signal on the Reset input will reset the counter to zero, and reset the carry-out LOW. A LOW signal on the Latch Enable input will latch the number in the counters into the internal output latches. A HIGH signal on Display Select input will select the number in the counter to be displayed; a LOW level signal on the Display Select will select the number in the output latch to be displayed.

The MM74C925 is a 4-decade counter and has Latch Enable, Clock and Reset inputs.

The MM74C926 is like the MM74C925 except that it has a display select and a carry-out used for cascading counters. The carry-out signal goes HIGH at 6000, goes back LOW at 0000.

The MM74C927 is like the MM74C926 except the second most significant digit divides by 6 rather than 10. Thus, if the clock input frequency is 10 Hz, the display would read tenths of seconds and minutes (i.e., 9:59.9).

The MM74C928 is like the MM74C926 except the most significant digit divides by 2 rather than 10 and the carry-out is an overflow indicator which is HIGH at 2000, and it goes

back LOW only when the counter is reset. Thus, this is a 3½-digit counter.

Features

- Wide supply voltage range: 3V to 6V
- Guaranteed noise margin: 1V
- High noise immunity: 0.45 V_{CC} (typ.)
- High segment sourcing current: 40 mA
@ V_{CC} = 1.6V, V_{CC} = 5V
- Internal multiplexing circuitry

Design Considerations

Segment resistors are desirable to minimize power dissipation and chip heating. The DS75492 serves as a good digit driver when it is desired to drive bright displays. When using this driver with a 5V supply at room temperature, the display can be driven without segment resistors to full illumination. The user must use caution in this mode however, to prevent overheating of the device by using too high a supply voltage or by operating at high ambient temperatures.

The input protection circuitry consists of a series resistor, and a diode to ground. Thus input signals exceeding V_{CC} will not be clamped. This input signal should not be allowed to exceed 15V.

Ordering Code:

Order Number	Package Number	Package Description
MM74C925N	N16E	16-Lead Plastic Dual-In-Line Package (PDIP), JEDEC MS-001, 0.300" Wide
MM74C926N	N18A	18-Lead Plastic Dual-In-Line Package (PDIP), JEDEC MS-001, 0.300" Wide
MM74C927N	N18A	18-Lead Plastic Dual-In-Line Package (PDIP), JEDEC MS-001, 0.300" Wide
MM74C928N	N18A	18-Lead Plastic Dual-In-Line Package (PDIP), JEDEC MS-001, 0.300" Wide

Connection Diagrams

Pin Assignments for DIP

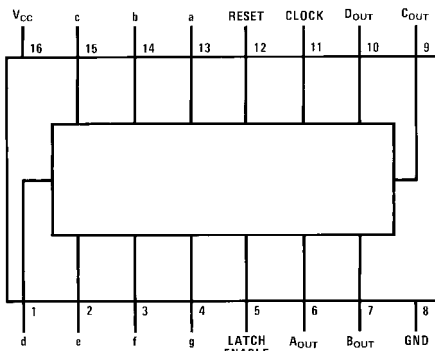

Top View
MM74C925

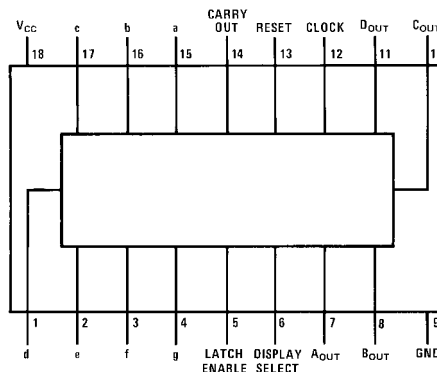

Top View
MM74C926, MM74C927, MM74C928

Functional Description

Reset — Asynchronous, active high

Display Select — High, displays output of counter
Low, displays output of latch

Latch Enable — High, flow through condition
Low, latch condition

Clock — Negative edge sensitive

Segment Output — Current sourcing with 40 mA @ $V_{OUT} = V_{CC} - 1.6V$ (typ.) Also, sink capability = 2 LTTL loads

Digit Output — Current sourcing with 1 mA @ $V_{OUT} = 1.75V$. Also, sink capability = 2 LTTL loads

Carry-Out — 2 LTTL loads. See carry-out waveforms.

Logic Diagrams

MM74C925

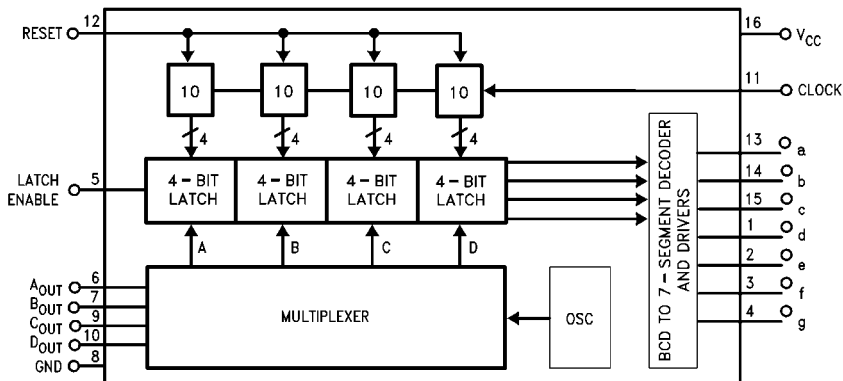

Logic Diagrams (Continued)

MM74C926

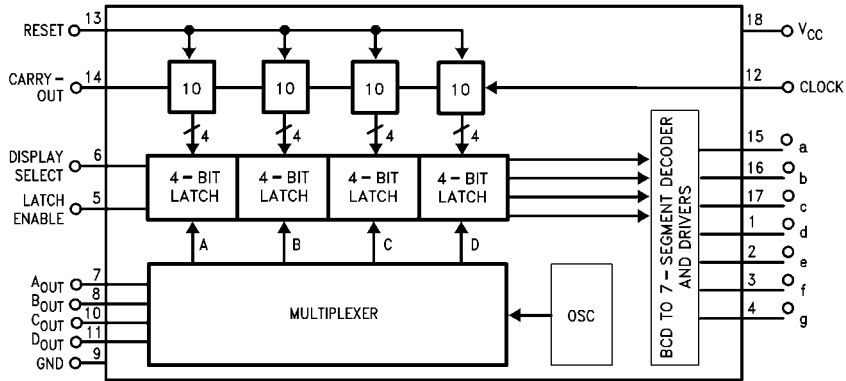

MM74C927

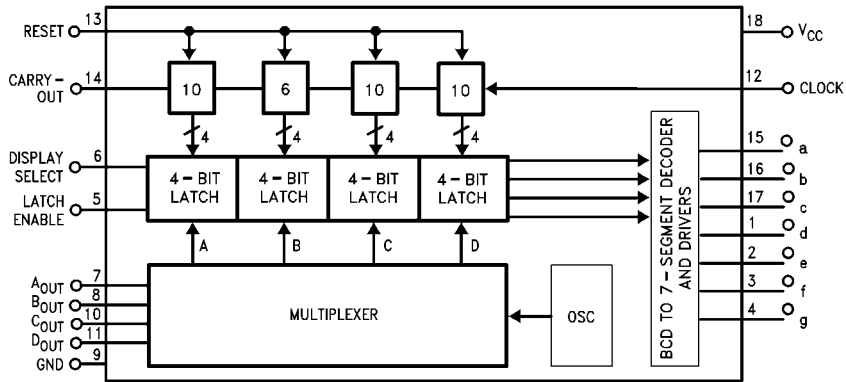

MM74C928

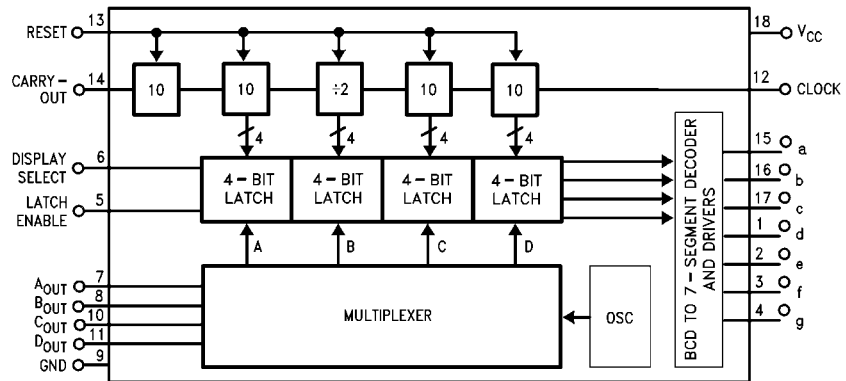

MM74C925 • MM74C926 • MM74C927 • MM74C928

Absolute Maximum Ratings (Note 1)		Operating V_{CC} Range	3V to 6V
Voltage at Any Output Pin	GND – 0.3V to $V_{CC} + 0.3V$	V_{CC}	6.5V
Voltage at Any Input Pin	GND – 0.3V to +15V	Lead Temperature	260°C
Operating Temperature Range (T_A)	–40°C to +85°C	(Soldering, 10 seconds)	
Storage Temperature Range	–65°C to +150°C		
Power Dissipation (P_D)	Refer to $P_{D(MAX)}$ vs T_A Graph		

Note 1: "Absolute Maximum Ratings" are those values beyond which the safety of the device cannot be guaranteed. Except for "Operating Temperature Range" they are not meant to imply that the devices should be operated at these limits. The Electrical Characteristics table provides conditions for actual device operation.

DC Electrical Characteristics

Min/Max limits apply at $-40^\circ\text{C} \leq t \leq +85^\circ\text{C}$, unless otherwise noted

Symbol	Parameter	Conditions	Min	Typ	Max	Units
CMOS TO CMOS						
$V_{IN(1)}$	Logical "1" Input Voltage	$V_{CC} = 5V$	3.5			V
$V_{IN(0)}$	Logical "0" Input Voltage	$V_{CC} = 5V$			1.5	V
$V_{OUT(1)}$	Logical "1" Output Voltage (Carry-Out and Digit Output Only)	$V_{CC} = 5V, I_O = -10 \mu A$	4.5			V
$V_{OUT(0)}$	Logical "0" Output Voltage	$V_{CC} = 5V, I_O = 10 \mu A$			0.5	V
$I_{IN(1)}$	Logical "1" Input Current	$V_{CC} = 5V, V_{IN} = 15V$		0.005	1	μA
$I_{IN(0)}$	Logical "0" Input Current	$V_{CC} = 5V, V_{IN} = 0V$	–1	–0.005		μA
I_{CC}	Supply Current	$V_{CC} = 5V$, Outputs Open Circuit, $V_{IN} = 0V$ or 5V		20	1000	μA
CMOS/LPTTL INTERFACE						
$V_{IN(1)}$	Logical "1" Input Voltage	$V_{CC} = 4.75V$	$V_{CC} - 2$			V
$V_{IN(0)}$	Logical "0" Input Voltage	$V_{CC} = 4.75V$			0.8	V
$V_{OUT(1)}$	Logical "1" Output Voltage (Carry-Out and Digit Output Only)	$V_{CC} = 4.75V$, $I_O = -360 \mu A$	2.4			V
$V_{OUT(0)}$	Logical "0" Output Voltage	$V_{CC} = 4.75V, I_O = 360 \mu A$			0.4	V
OUTPUT DRIVE						
V_{OUT}	Output Voltage (Segment Sourcing Output)	$I_{OUT} = -65 \text{ mA}, V_{CC} = 5V, T_j = 25^\circ\text{C}$ $I_{OUT} = -40 \text{ mA}, V_{CC} = 5V, T_j = 100^\circ\text{C}$ $T_j = 150^\circ\text{C}$	$V_{CC} - 2$ $V_{CC} - 1.6$ $V_{CC} - 2$	$V_{CC} - 1.3$ $V_{CC} - 1.2$ $V_{CC} - 1.4$		V V V
R_{ON}	Output Resistance (Segment Sourcing Output) Output Resistance (Segment Output) Temperature Coefficient	$I_{OUT} = -65 \text{ mA}, V_{CC} = 5V, T_j = 25^\circ\text{C}$ $I_{OUT} = -40 \text{ mA}, V_{CC} = 5V, T_j = 100^\circ\text{C}$ $T_j = 150^\circ\text{C}$		20 30 35 0.6	32 40 50 0.8	Ω Ω Ω %/°C
I_{SOURCE}	Output Source Current (Digit Output)	$V_{CC} = 4.75V, V_{OUT} = 1.75V, T_j = 150^\circ\text{C}$	–1	–2		mA
I_{SOURCE}	Output Source Current (Carry-Out)	$V_{CC} = 5V, V_{OUT} = 0V, T_j = 25^\circ\text{C}$	–1.75	–3.3		mA
I_{SINK}	Output Sink Current (All Outputs)	$V_{CC} = 5V, V_{OUT} = V_{CC}, T_j = 25^\circ\text{C}$	1.75	3.6		mA
θ_{JA}	Thermal Resistance	MM74C925: (Note 2) MM74C926, MM74C927, MM74C928		75 70	100 90	°C/W °C/W

Note 2: θ_{JA} measured in free-air with device soldered into printed circuit board.

AC Electrical Characteristics (Note 3)

T_A = 25°C, C_L = 50 pF, unless otherwise noted

Symbol	Parameter	Conditions	Min	Typ	Max	Units
f _{MAX}	Maximum Clock Frequency	V _{CC} = 5V, T _J = 25°C Square Wave Clock T _J = 100°C	2 1.5	4 3		MHz MHz
t _r , t _f	Maximum Clock Rise or Fall Time	V _{CC} = 5V			15	μs
t _{WR}	Reset Pulse Width	V _{CC} = 5V T _J = 25°C T _J = 100°C	250 320	100 125		ns ns
t _{WLE}	Latch Enable Pulse Width	V _{CC} = 5V T _J = 25°C T _J = 100°C	250 320	100 125		ns ns
t _{SET(CK, LE)}	Clock to Latch Enable Set-Up Time	V _{CC} = 5V T _J = 25°C T _J = 100°C	2500 3200	1250 1600		ns ns
t _{LR}	Latch Enable to Reset Wait Time	V _{CC} = 5V T _J = 25°C T _J = 100°C	0 0	-100 -100		ns ns
t _{SET(R, LE)}	Reset to Latch Enable Set-Up Time	V _{CC} = 5V T _J = 25°C T _J = 100°C	320 400	160 200		ns ns
f _{MUX}	Multiplexing Output Frequency	V _{CC} = 5V	1000			Hz
C _{IN}	Input Capacitance	Any Input (Note 4)	5			pF

Note 3: AC Parameters are guaranteed by DC correlated testing.

Note 4: Capacitance is guaranteed by periodic testing.

Typical Performance Characteristics

Typical Segment Current vs Output Voltage

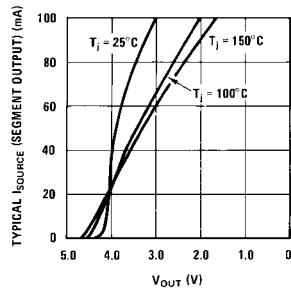

Maximum Power Dissipation vs Ambient Temperature

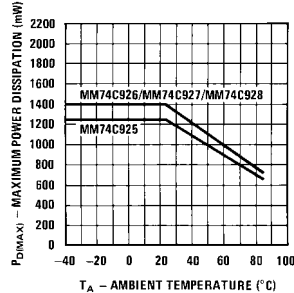

Note: V_D = Voltage across digit driver

Typical Average Segment Current vs Segment Resistor Value

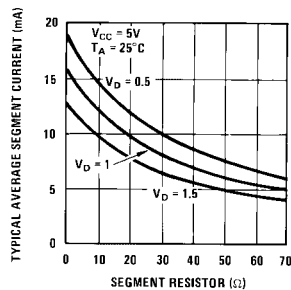

Typical Performance Characteristics (Continued)

Segment Output Driver

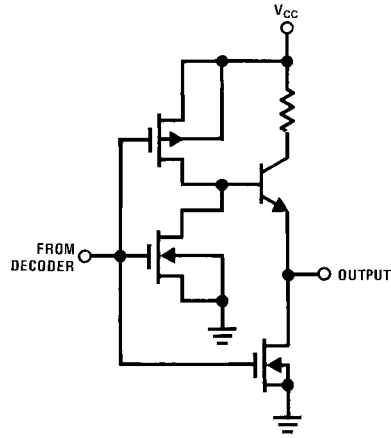

Input Protection

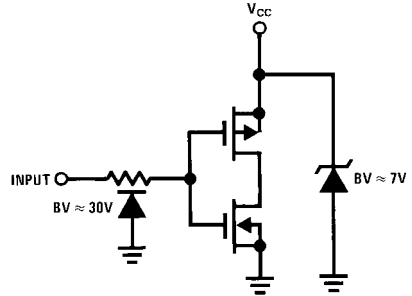

Common Cathode LED Display

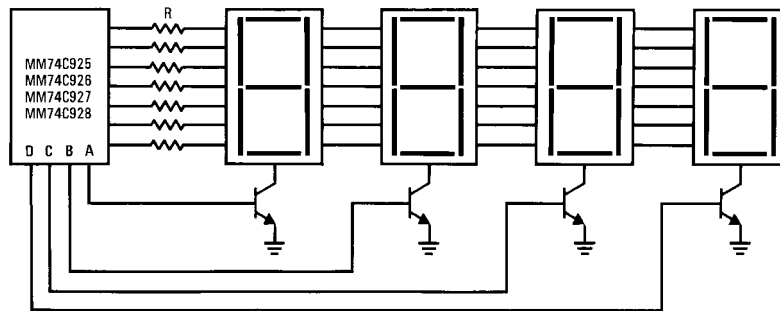

Segment Identification

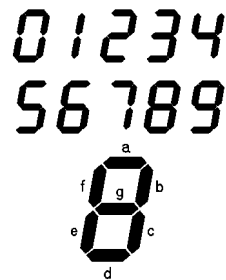

Switching Time Waveforms

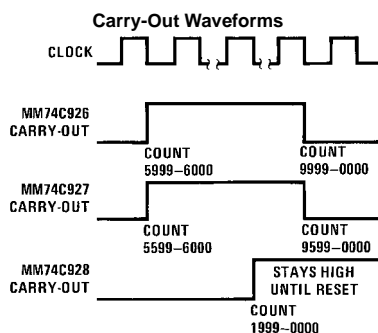
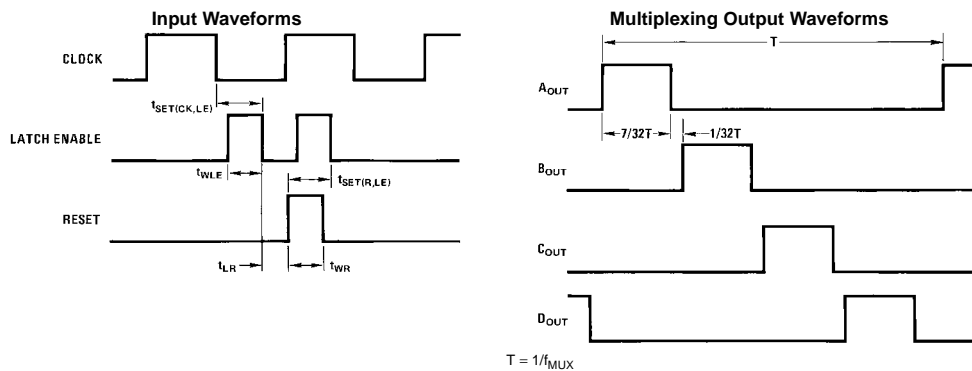

Physical Dimensions inches (millimeters) unless otherwise noted

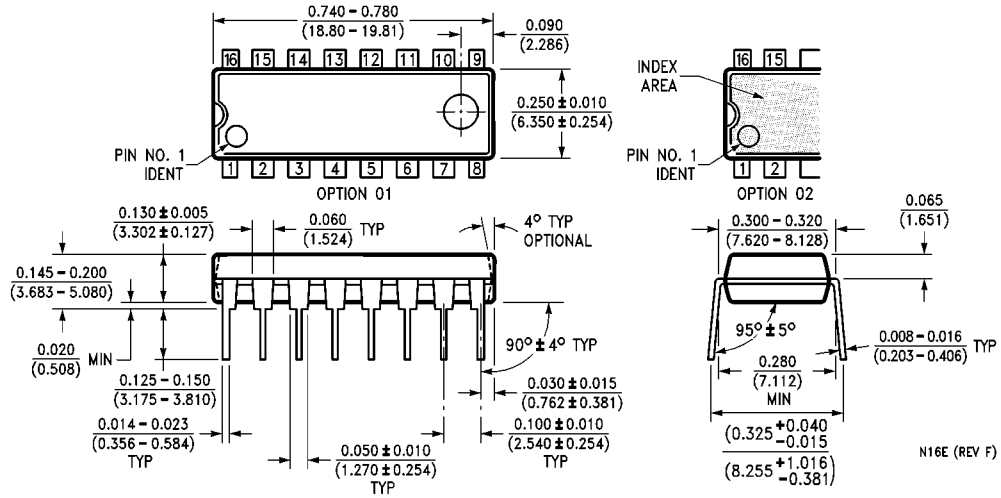

**16-Lead Plastic Dual-In-Line Package (PDIP), JEDEC MS-001, 0.300" Wide
Package Number N16E**

Physical Dimensions inches (millimeters) unless otherwise noted (Continued)

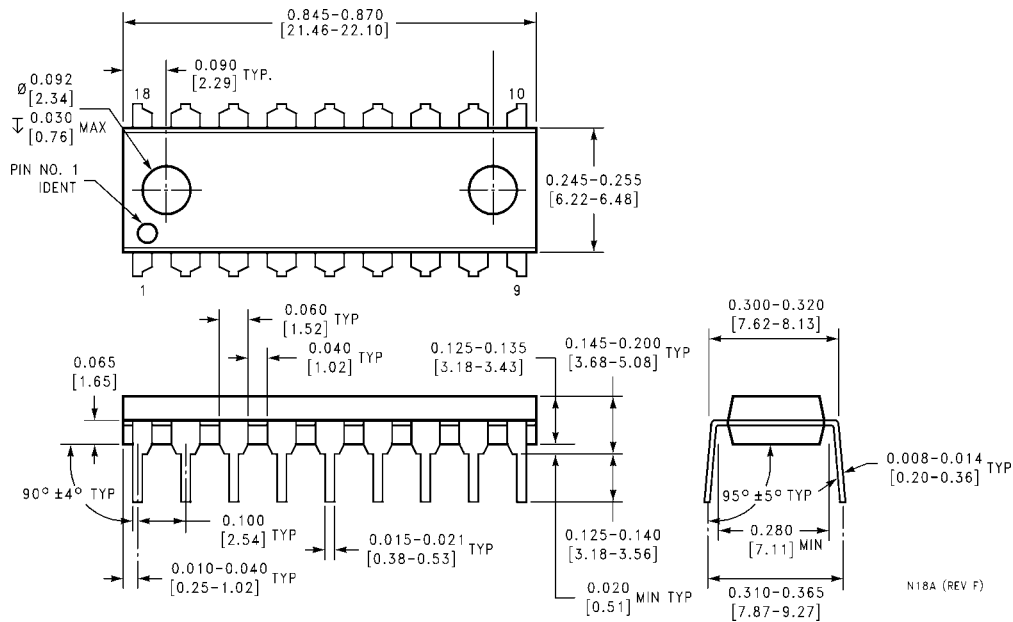

**18-Lead Plastic Dual-In-Line Package (PDIP), JEDEC MS-001, 0.300" Wide
Package Number N18A**

LIFE SUPPORT POLICY

FAIRCHILD'S PRODUCTS ARE NOT AUTHORIZED FOR USE AS CRITICAL COMPONENTS IN LIFE SUPPORT DEVICES OR SYSTEMS WITHOUT THE EXPRESS WRITTEN APPROVAL OF THE PRESIDENT OF FAIRCHILD SEMICONDUCTOR CORPORATION. As used herein:

1. Life support devices or systems are devices or systems which, (a) are intended for surgical implant into the body, or (b) support or sustain life, and (c) whose failure to perform when properly used in accordance with instructions for use provided in the labeling, can be reasonably expected to result in a significant injury to the user.
2. A critical component in any component of a life support device or system whose failure to perform can be reasonably expected to cause the failure of the life support device or system, or to affect its safety or effectiveness.

www.fairchildsemi.com

Fairchild does not assume any responsibility for use of any circuitry described, no circuit patent licenses are implied and Fairchild reserves the right at any time without notice to change said circuitry and specifications.