

MM74HC175 Quad D-Type Flip-Flop With Clear

General Description

The MM74HC175 high speed D-type flip-flop with complementary outputs utilizes advanced silicon-gate CMOS technology to achieve the high noise immunity and low power consumption of standard CMOS integrated circuits, along with the ability to drive 10 LS-TTL loads.

Information at the D inputs of the MM74HC175 is transferred to the Q and \bar{Q} outputs on the positive going edge of the clock pulse. Both true and complement outputs from each flip flop are externally available. All four flip-flops are controlled by a common clock and a common CLEAR. Clearing is accomplished by a negative pulse at the CLEAR input. All four Q outputs are cleared to a logical "0" and all four \bar{Q} outputs to a logical "1."

The 74HC logic family is functionally as well as pin-out compatible with the standard 74LS logic family. All inputs are protected from damage due to static discharge by internal diode clamps to V_{CC} and ground.

Features

- Typical propagation delay: 15 ns
- Wide operating supply voltage range: 2–6V
- Low input current: 1 μ A maximum
- Low quiescent supply current: 80 μ A maximum (74HC)
- High output drive current: 4 mA minimum (74HC)

Ordering Code:

Order Number	Package Number	Package Description
MM74HC175M	M16A	16-Lead Small Outline Integrated Circuit (SOIC), JEDEC MS-012, 0.150" Narrow
MM74HC175SJ	M16D	16-Lead Small Outline Package (SOP), EIAJ TYPE II, 5.3mm Wide
MM74HC175MTC	MTC16	16-Lead Thin Shrink Small Outline Package (TSSOP), JEDEC MO-153, 4.4mm Wide
MM74HC175N	N16E	16-Lead Plastic Dual-In-Line Package (PDIP), JEDEC MS-001, 0.300" Wide

Devices also available in Tape and Reel. Specify by appending the suffix letter "X" to the ordering code.

Connection Diagram

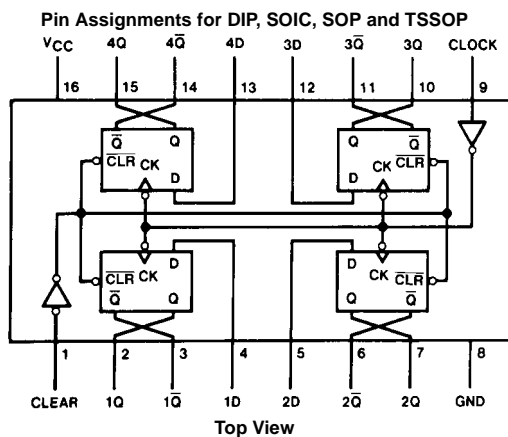

Truth Table

(Each Flip-Flop)

Inputs			Outputs	
Clear	Clock	D	Q	\bar{Q}
L	X	X	L	H
H	↑	H	H	L
H	↑	L	L	H
H	L	X	Q_0	\bar{Q}_0

H = HIGH Level (steady state)
L = LOW Level (steady state)
X = Irrelevant
↑ = Transition from LOW-to-HIGH level
 Q_0 = The level of Q before the indicated steady-state input conditions were established

Logic Diagram

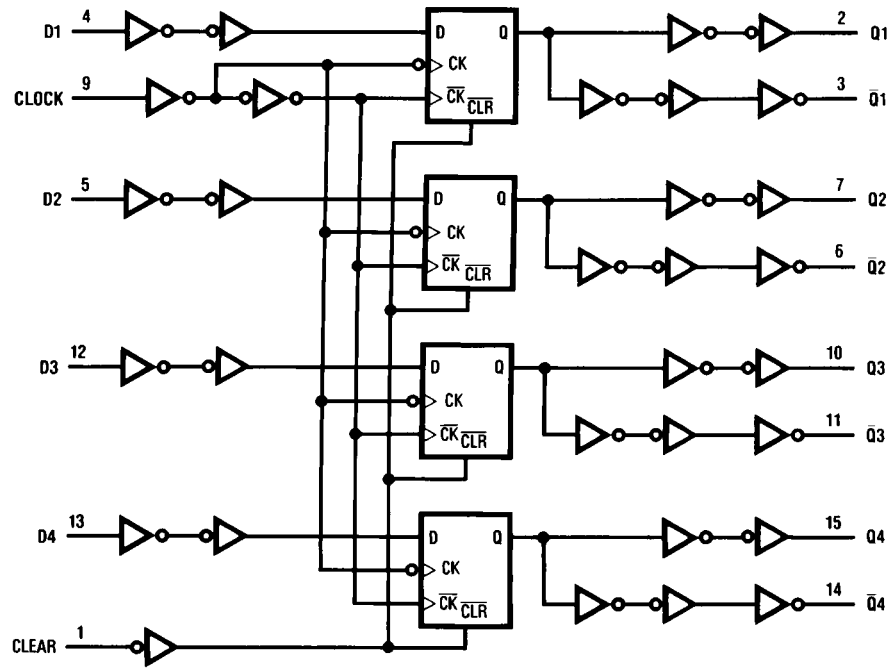

Absolute Maximum Ratings (Note 1)				Recommended Operating Conditions				
(Note 2)								
Supply Voltage (V_{CC})	-0.5 to +7.0V			Min	Max	Units		
DC Input Voltage (V_{IN})	-1.5 to $V_{CC} + 1.5V$			2	6	V		
DC Output Voltage (V_{OUT})	-0.5 to $V_{CC} + 0.5V$							
Clamp Diode Current (I_{IK}, I_{OK})	± 20 mA			0	V_{CC}	V		
DC Output Current, per pin (I_{OUT})	± 25 mA			Operating Temperature Range (T_A)				
DC V_{CC} or GND Current, per pin (I_{CC})	± 50 mA			-40	+85	$^{\circ}C$		
Storage Temperature Range (T_{STG})	-65 $^{\circ}C$ to +150 $^{\circ}C$			Input Rise or Fall Times				
Power Dissipation (P_D)				(t_r, t_f) $V_{CC} = 2.0V$		1000	ns	
(Note 3)	600 mW			$V_{CC} = 4.5V$		500	ns	
S.O. Package only	500 mW			$V_{CC} = 6.0V$		400	ns	
Lead Temperature (T_L)				Note 1: Absolute Maximum Ratings are those values beyond which damage to the device may occur.				
(Soldering 10 seconds)	260 $^{\circ}C$			Note 2: Unless otherwise specified all voltages are referenced to ground.				
				Note 3: Power Dissipation temperature derating — plastic "N" package: -12 mW/ $^{\circ}C$ from 65 $^{\circ}C$ to 85 $^{\circ}C$.				
DC Electrical Characteristics (Note 4)								
Symbol	Parameter	Conditions	V_{CC}	$T_A = 25^{\circ}C$			Units	
				Guaranteed Limits				
V_{IH}	Minimum HIGH Level Input Voltage		2.0V		1.5	1.5	1.5	V
			4.5V		3.15	3.15	3.15	V
			6.0V		4.2	4.2	4.2	V
V_{IL}	Maximum LOW Level Input Voltage		2.0V		0.5	0.5	0.5	V
			4.5V		1.35	1.35	1.35	V
			6.0V		1.8	1.8	1.8	V
V_{OH}	Minimum HIGH Level Output Voltage	$V_{IN} = V_{IH}$ or V_{IL} $ I_{OUT} \leq 20 \mu A$	2.0V	2.0	1.9	1.9	1.9	V
			4.5V	4.5	4.4	4.4	4.4	V
			6.0V	6.0	5.9	5.9	5.9	V
	Maximum LOW Level Output Voltage	$V_{IN} = V_{IH}$ or V_{IL} $ I_{OUT} \leq 4.0$ mA $ I_{OUT} \leq 5.2$ mA	4.5V	4.2	3.98	3.84	3.7	V
			6.0V	5.7	5.48	5.34	5.2	V
V_{OL}	Maximum LOW Level Output Voltage	$V_{IN} = V_{IH}$ or V_{IL} $ I_{OUT} \leq 20 \mu A$	2.0V	0	0.1	0.1	0.1	V
			4.5V	0	0.1	0.1	0.1	V
			6.0V	0	0.1	0.1	0.1	V
	Maximum Input Current	$V_{IN} = V_{CC}$ or GND	4.5V	0.2	0.26	0.33	0.4	V
			6.0V	0.2	0.26	0.33	0.4	V
I_{IN}	Maximum Input Current	$V_{IN} = V_{CC}$ or GND	6.0V		± 0.1	± 1.0	± 1.0	μA
I_{CC}	Maximum Quiescent Supply Current	$V_{IN} = V_{CC}$ or GND $I_{OUT} = 0 \mu A$	6.0V		8	80	160	μA
Note 4: For a power supply of 5V $\pm 10\%$ the worst case output voltages (V_{OH} , and V_{OL}) occur for HC at 4.5V. Thus the 4.5V values should be used when designing with this supply. Worst case V_{IH} and V_{IL} occur at $V_{CC} = 5.5V$ and 4.5V respectively. (The V_{IH} value at 5.5V is 3.85V.) The worst case leakage current (I_{IN} , I_{CC} , and I_{OZ}) occur for CMOS at the higher voltage and so the 6.0V values should be used.								

AC Electrical Characteristics						
$V_{CC} = 5V, T_A = 25^\circ C, C_L = 15 \text{ pF}, t_r = t_f = 6 \text{ ns}$						
Symbol	Parameter	Conditions	Typ	Guaranteed Limit	Units	
f_{MAX}	Maximum Operating Frequency		60	35	MHz	
t_{PHL}, t_{PLH}	Maximum Propagation Delay, Clock to Q or \bar{Q}		15	25	ns	
t_{PHL}, t_{PLH}	Maximum Propagation Delay, Reset to Q or \bar{Q}		13	21	ns	
t_{REC}	Minimum Removal Time, Clear to Clock			20	ns	
t_S	Minimum Setup Time, Data to Clock			20	ns	
t_H	Minimum Hold Time, Data from Clock			0	ns	
t_W	Minimum Pulse Width, Clock or Clear		10	16	ns	

AC Electrical Characteristics								
$V_{CC} = 2.0V \text{ to } 6.0V, C_L = 50 \text{ pF}, t_r = t_f = 6 \text{ ns}$ (unless otherwise specified)								
Symbol	Parameter	Conditions	V_{CC}	$T_A = 25^\circ C$		$T_A = -40 \text{ to } 85^\circ C$	$T_A = -55 \text{ to } 125^\circ C$	Units
				Typ	Guaranteed Limits			
f_{MAX}	Maximum Operating Frequency		2.0V	12	6	5	4	MHz
			4.5V	60	30	24	20	MHz
			6.0V	70	35	28	24	MHz
t_{PHL}, t_{PLH}	Maximum Propagation Delay, Clock to Q or \bar{Q}		2.0V	80	150	190	225	ns
			4.5V	15	30	38	45	ns
			6.0V	13	26	32	38	ns
t_{PHL}, t_{PLH}	Maximum Propagation Delay, Reset to Q or \bar{Q}		2.0V	64	125	158	186	ns
			4.5V	14	25	32	37	ns
			6.0V	12	21	27	32	ns
t_{REM}	Minimum Removal Time Clear to Clock		2.0V		100	125	150	ns
			4.5V		20	25	30	ns
			6.0V		17	21	25	ns
t_S	Minimum Setup Time Data to Clock		2.0V		100	125	150	ns
			4.5V		20	25	30	ns
			6.0V		17	21	25	ns
t_H	Minimum Hold Time Data from Clock		2.0V		0	0	0	ns
			4.5V		0	0	0	ns
			6.0V		0	0	0	ns
t_W	Minimum Pulse Width Clear or Clock		2.0V	30	80	100	120	ns
			4.5V	9	16	20	24	ns
			6.0V	8	14	17	20	ns
t_r, t_f	Maximum Input Rise and Fall Time		2.0V		1000	1000	1000	ns
			4.5V		500	500	500	ns
			6.0V		400	400	400	ns
t_{TLH}, t_{THL}	Maximum Output Rise and Fall Time		2.0V	30	75	95	110	ns
			4.5V	9	15	19	22	ns
			6.0V	8	13	16	19	ns
C_{PD}	Power Dissipation Capacitance (Note 5)	(per package)		150				pF
C_{IN}	Maximum Input Capacitance			5	10	10	10	pF

Note 5: C_{PD} determines the no load dynamic power consumption, $P_D = C_{PD} V_{CC}^2 f + I_{CC} V_{CC}$, and the no load dynamic current consumption, $I_S = C_{PD} V_{CC} f + I_{CC}$.

Physical Dimensions inches (millimeters) unless otherwise noted

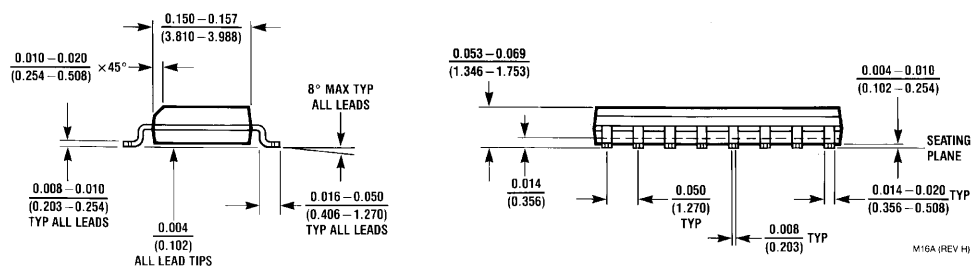
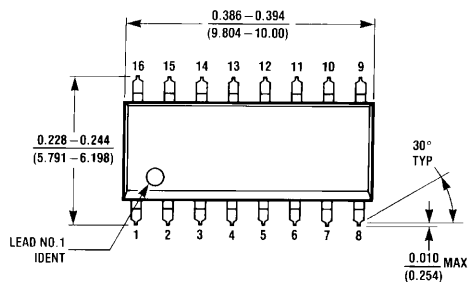

**16-Lead Small Outline Integrated Circuit (SOIC), JEDEC MS-012, 0.150" Narrow
Package Number M16A**

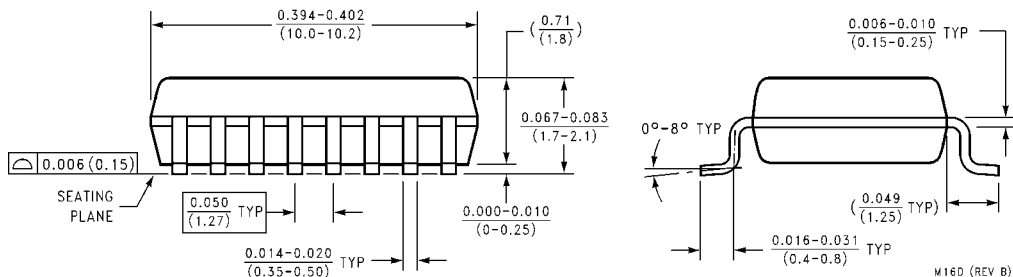
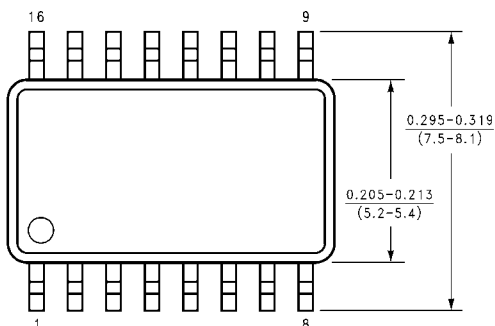

**16-Lead Small Outline Package (SOP), EIAJ TYPE II, 5.3mm Wide
Package Number M16D**

Physical Dimensions inches (millimeters) unless otherwise noted (Continued)

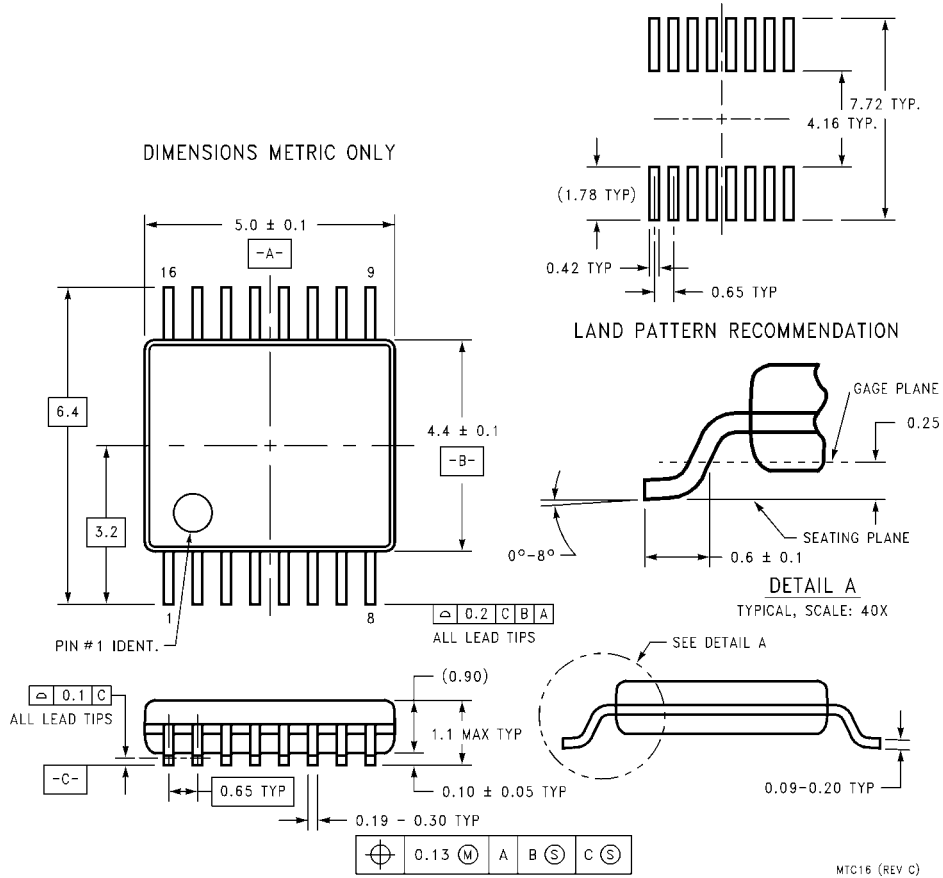

**16-Lead Thin Shrink Small Outline Package (TSSOP), JEDEC MO-153, 4.4mm Wide
Package Number MTC16**

Physical Dimensions inches (millimeters) unless otherwise noted (Continued)

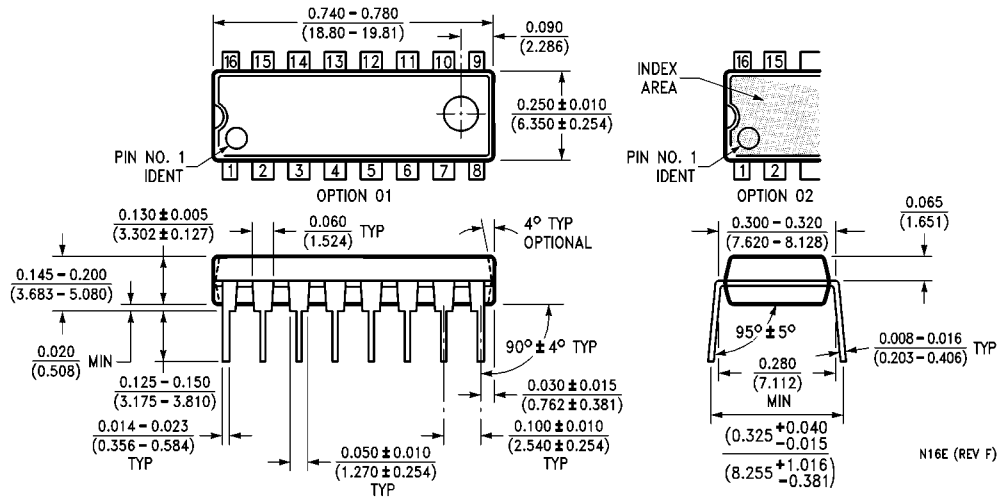

16-Lead Plastic Dual-In-Line Package (PDIP), JEDEC MS-001, 0.300" Wide Package Number N16E

LIFE SUPPORT POLICY

FAIRCHILD'S PRODUCTS ARE NOT AUTHORIZED FOR USE AS CRITICAL COMPONENTS IN LIFE SUPPORT DEVICES OR SYSTEMS WITHOUT THE EXPRESS WRITTEN APPROVAL OF THE PRESIDENT OF FAIRCHILD SEMICONDUCTOR CORPORATION. As used herein:

1. Life support devices or systems are devices or systems which, (a) are intended for surgical implant into the body, or (b) support or sustain life, and (c) whose failure to perform when properly used in accordance with instructions for use provided in the labeling, can be reasonably expected to result in a significant injury to the user.
2. A critical component in any component of a life support device or system whose failure to perform can be reasonably expected to cause the failure of the life support device or system, or to affect its safety or effectiveness.

www.fairchildsemi.com

Fairchild does not assume any responsibility for use of any circuitry described, no circuit patent licenses are implied and Fairchild reserves the right at any time without notice to change said circuitry and specifications.