

# NB7L111M

## 2.5V / 3.3V, 6.125Gb/s 1:10 Differential Clock/Data Driver with CML Output

### Description

The NB7L111M is a low skew 1-to-10 differential clock/data driver, designed with clock/data distribution in mind. It accepts two clock/data sources into multiplexer input and reproduces ten identical CML differential outputs. This device is ideal for clock/data distribution across the backplane or a board, and redundant clock switchover applications.

The input signals can be either differential or single-ended (if the external reference voltage is provided). Differential inputs incorporate internal 50 Ω termination resistors and accept Negative ECL (NECL), Positive ECL (PECL), LVCMOS, LVTTTL, CML, or LVDS (using appropriate power supplies). The differential 16 mA CML output provides matching internal 50 Ω termination, and 400 mV output swing when externally terminated 50 Ω to V<sub>CC</sub>.

The NB7L111M operates from a 2.5 V ±5% supply or a 3.3 V ±5% supply and is guaranteed over the full industrial temperature range of -40°C to +85°C. This device is packaged in a low profile 8x8 mm, QFN-52 package with 0.5 mm pitch (see package dimension on the back of the datasheet).

Application notes, models, and support documentation are available at [www.onsemi.com](http://www.onsemi.com).

### Features

- Maximum Input Clock Frequency > 5.5 GHz Typical
- Maximum Input Data Rate > 6.125 Gb/s Typical
- < 0.5 ps Maximum Clock RMS Jitter
- < 15 ps Maximum Data Dependent Jitter at 3.125 Gb/s
- 50 ps Typical Rise and Fall Times
- 240 ps Typical Propagation Delay
- 2 ps Typical Duty Cycle Skew
- 10 ps Typical Within Device Skew
- 15 ps Typical Device-to-Device Skew
- Operating Range: V<sub>CC</sub> = 2.5 V ±5 and 3.3 V ±5
- 400 mV Differential CML Output Swing
- 50 Ω Internal Input and Output Termination Resistors
- Pb-Free Packages are Available\*



ON Semiconductor®

<http://onsemi.com>

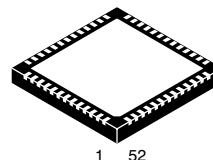

QFN-52  
MN SUFFIX  
CASE 485M

### MARKING DIAGRAM\*

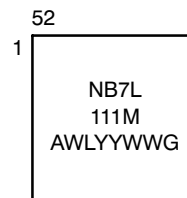

A = Assembly Site  
WL = Wafer Lot  
YY = Year  
WW = Work Week  
G = Pb-Free Package

\*For additional marking information, refer to Application Note AND8002/D.

### ORDERING INFORMATION

See detailed ordering and shipping information in the package dimensions section on page 12 of this data sheet.

\*For additional information on our Pb-Free strategy and soldering details, please download the ON Semiconductor Soldering and Mounting Techniques Reference Manual, SOLDERRM/D.

# NB7L111M

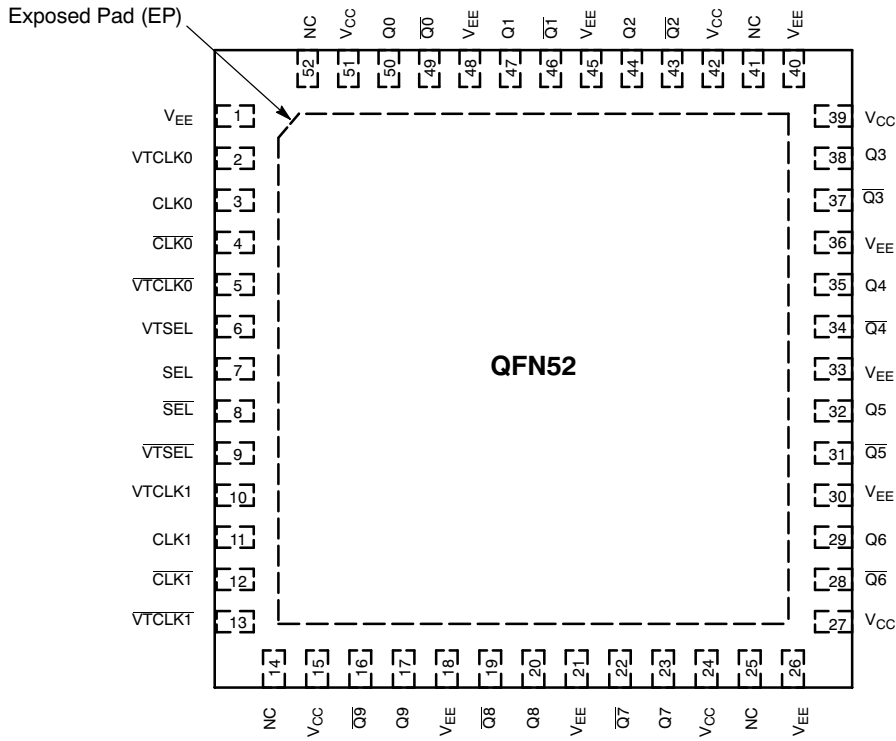

Figure 1. Pinout (Top View)

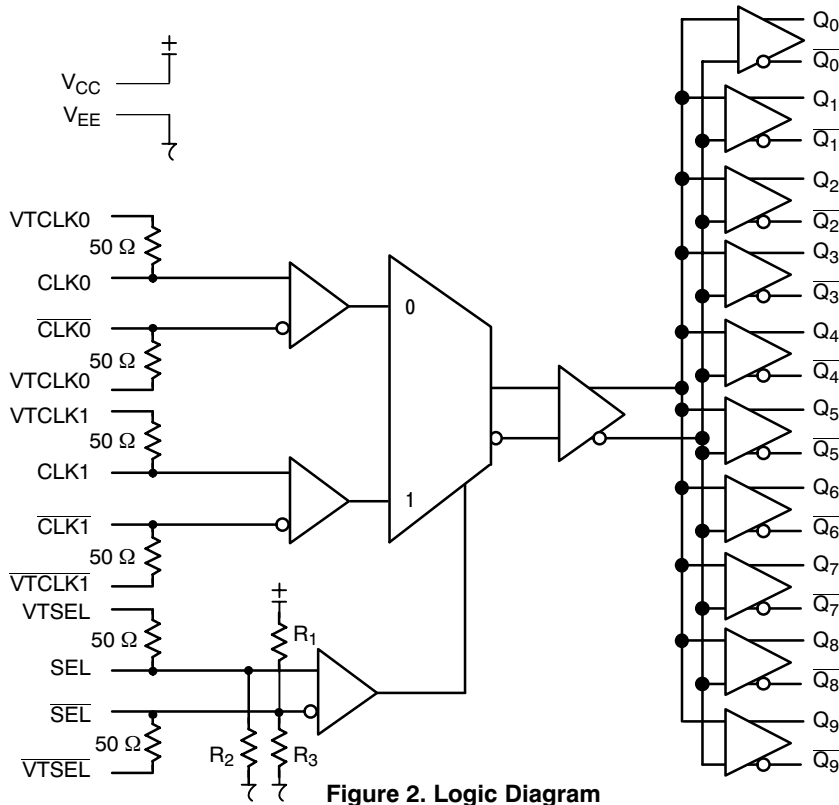

Figure 2. Logic Diagram

Table 1. FUNCTION TABLE

SEL	SEL	CLK0/CLK0	CLK1/CLK1
LOW	HIGH	ON	OFF
HIGH	LOW	OFF	ON

# NB7L111M

**Table 2. PIN DESCRIPTION**

Pin	Name	I/O	Description
15, 24, 27, 39, 42, 51	V <sub>CC</sub>	-	Positive supply voltage. All V <sub>CC</sub> pins must be externally connected to power supply to guarantee proper operation.
1, 18, 21, 26, 30, 33, 36, 40, 45, 48	V <sub>EE</sub>	-	Negative supply voltage. All V <sub>EE</sub> pins must be externally connected to power supply to guarantee proper operation.
2	VTCLK0	-	Internal 50 Ω termination pin for CLK0. (Note 2)
3	CLK0	LVPECL, CML, LVC MOS, LV TTL, LVDS Input	Non-inverted differential clock/data input 0 (Note 2).
4	$\overline{\text{CLK}}_0$	LVPECL, CML, LVC MOS, LV TTL, LVDS Input	Inverted differential clock/data input 0 (Note 2).
5	$\overline{\text{VTCLK}}_0$	-	Internal 50 Ω termination pin for $\overline{\text{CLK}}_0$ . (Note 2)
6	VTSEL	-	Internal 50 Ω termination pin for SEL. (Note 2)
7	SEL	LVPECL, CML, LVC MOS, LV TTL, LVDS Input	Non-inverted differential clock/data select input. Internal 75 kΩ to V <sub>EE</sub> .
8	$\overline{\text{SEL}}$	LVPECL, CML, LVC MOS, LV TTL, LVDS Input	Inverted differential clock/data select input. Internal 56 kΩ to V <sub>CC</sub> and 56 kΩ to V <sub>EE</sub> bias this pin to (V <sub>CC</sub> -V <sub>EE</sub> )/2.
9	$\overline{\text{VTSEL}}$	LVPECL, CML, LVC MOS, LV TTL, LVDS Input	Internal 50 Ω termination pin for $\overline{\text{SEL}}$ . (Note 2)
10	VTCLK1	-	Internal 50 Ω termination pin for CLK1. (Note 2)
11	CLK1	LVPECL, CML, LVC MOS, LV TTL, LVDS Input	Non-inverted differential clock/data input 1 (Note 2).
12	$\overline{\text{CLK}}_1$	LVPECL, CML, LVC MOS, LV TTL, LVDS Input	Inverted differential clock/data input 1 (Note 2).
13	$\overline{\text{VTCLK}}_1$	-	Internal 50 Ω termination pin for $\overline{\text{CLK}}_1$ . (Note 2)
14, 25, 41, 52	NC	-	
17, 20, 23, 29, 32, 35, 38, 44, 47, 50	Q[0-9]	CML Outputs	Non-inverted CML outputs [0-9] with internal 50 Ω source termination resistor (Note 1).
16, 19, 22, 28, 31, 34, 37, 43, 46, 49	$\overline{\text{Q}}[0-9]$	CML Outputs	Inverted CML outputs [0-9] with internal 50 Ω source termination resistor (Note 1).
EP	-	-	Exposed Pad (EP). The thermally exposed pad on package bottom (see case drawing) must be attached to a heat-sinking conduit on the printed circuit board.

1. CML output requires 50 Ω receiver termination resistor to V<sub>CC</sub> for proper operation.
2. In the differential configuration when the input termination pin (VTCLK,  $\overline{\text{VTCLK}}$ ) are connected to a common termination voltage or left open, and if no signal is applied on CLK and  $\overline{\text{CLK}}$  then the device will be susceptible to self-oscillation.

# NB7L111M

**Table 3. ATTRIBUTES**

Characteristics		Value	
Input Default State Resistors	R1, R3 R2	56 kΩ 75 kΩ	
ESD Protection	Human Body Model Machine Model	> 1400 V > 80 V	
Moisture Sensitivity (Note 3)		Pb Pkg	Pb-Free Pkg
	QFN-52	Level 2	Level 1
Flammability Rating	Oxygen Index: 28 to 34	UL 94 V-0 @ 0.125 in	
Transistor Count		339	
Meets or exceeds JEDEC Spec EIA/JESD78 IC Latchup Test			

3. For additional information, see Application Note AND8003/D.

**Table 4. MAXIMUM RATINGS** (Note 4)

Symbol	Parameter	Condition 1	Condition 2	Rating	Unit
V <sub>CC</sub>	Positive Power Supply	V <sub>EE</sub> = 0 V		3.6	V
V <sub>I</sub>	Input Voltage	V <sub>EE</sub> = 0 V	V <sub>EE</sub> ≤ V <sub>I</sub> ≤ V <sub>CC</sub>	3.6	V
V <sub>INPP</sub>	Differential Input Voltage  CLK - $\overline{\text{CLK}}$	V <sub>CC</sub> - V <sub>EE</sub> ≥ 2.8 V V <sub>CC</sub> - V <sub>EE</sub> < 2.8 V		2.8  V <sub>CC</sub> - V <sub>EE</sub>	V V
I <sub>in</sub>	Input Current Through R <sub>T</sub> (50 Ω Resistor)	Continuous Surge		25 50	mA mA
I <sub>out</sub>	Output Current	Continuous Surge		25 50	mA mA
T <sub>A</sub>	Operating Temperature Range	QFN52		-40 to +85	°C
T <sub>stg</sub>	Storage Temperature Range			-65 to +150	°C
θ <sub>JA</sub>	Thermal Resistance (Junction-to-Ambient) (Note 5)	0 lfpm 500 lfpm	QFN52	25 19.6	°C/W °C/W
θ <sub>JC</sub>	Thermal Resistance (Junction-to-Case)	1S2P (Note 8)	QFN52	21	°C/W
T <sub>sol</sub>	Wave Solder	Pb Pb-Free		265 265	°C

Stresses exceeding Maximum Ratings may damage the device. Maximum Ratings are stress ratings only. Functional operation above the Recommended Operating Conditions is not implied. Extended exposure to stresses above the Recommended Operating Conditions may affect device reliability.

4. Maximum Ratings are those values beyond which device damage may occur.  
 5. JEDEC standard multilayer board - 1S2P (1 signal, 2 power).

# NB7L111M

**Table 5. DC CHARACTERISTICS**  $V_{CC} = 2.375\text{ V}$   $2.625\text{ V}$  and  $3.135\text{ V}$  to  $3.465\text{ V}$ ,  $V_{EE} = 0\text{ V}$ ,  $T_A = -40^\circ\text{C}$  to  $+85^\circ\text{C}$  (Notes 6 and 7)

Symbol	Characteristic	Min	Typ	Max	Unit
$I_{CC}$	Power Supply Current (Inputs and Outputs Open) $V_{CC} = 2.375\text{ V}$ to $2.625\text{ V}$ $V_{CC} = 3.135\text{ V}$ to $3.465\text{ V}$	255 270	290 305	325 340	mA
$V_{OH}$	Output HIGH Voltage (Notes 6 and 7)	$V_{CC} - 40$	$V_{CC} - 20$	$V_{CC}$	mV
$V_{OL}$	Output LOW Voltage (Notes 6 and 7) $V_{CC} = 2.375\text{ V}$ to $2.625\text{ V}$ $V_{CC} = 3.135\text{ V}$ to $3.465\text{ V}$	$V_{CC} - 440$ $V_{CC} - 490$	$V_{CC} - 350$ $V_{CC} - 400$	$V_{CC} - 290$ $V_{CC} - 340$	mV

**DIFFERENTIAL INPUT DRIVEN SINGLE-ENDED** (See Figures 13 and 15)

$V_{th}$	Input Threshold Reference Voltage Range (Note 8)	1125		$V_{CC} - 75$	mV
$V_{IH}$	Single-ended Input HIGH Voltage (Note 7)	$V_{th} + 75$		$V_{CC}$	mV
$V_{IL}$	Single-ended Input LOW Voltage (Note 7)	$V_{EE}$		$V_{CC} - 150$	mV

**DIFFERENTIAL INPUTS DRIVEN DIFFERENTIALLY** (See Figures 14 and 16)

$V_{IHD}$	Differential Input HIGH Voltage	1200		$V_{CC}$	mV
$V_{ILD}$	Differential Input LOW Voltage	$V_{EE}$		$V_{CC} - 75$	mV
$V_{CMR}$	Input Common Mode Range (Differential Configuration) (Note 9)	1163		$V_{CC} - 37$	mV
$V_{ID}$	Differential Input Voltage ( $V_{IHD} - V_{ILD}$ )	75		2500	mV
$I_{IH}$	Input HIGH Current (Termination Pins Open)	$\frac{CLK[0-1]}{SEL/SEL}$ -100 -150	5	100 150	$\mu\text{A}$
$I_{IL}$	Input LOW Current (Termination Pins Open)	$\frac{CLK[0-1]}{SEL/SEL}$ -100 -150	5	100 150	$\mu\text{A}$
$R_{TIN}$	Internal Input Termination Resistor	45	50	55	$\Omega$
$R_{TOUT}$	Internal Output Termination Resistor	45	50	55	$\Omega$
$R_{Temp}$ Coef	Internal I/O Termination Resistor Temperature Coefficient		-3.75		m $\Omega$ /C

NOTE: Device will meet the specifications after thermal equilibrium has been established when mounted in a test socket or printed circuit board with maintained transverse airflow greater than 500 lfpm. Electrical parameters are guaranteed only over the declared operating temperature range. Functional operation of the device exceeding these conditions is not implied. Device specification limit values are applied individually under normal operating conditions and not valid simultaneously.

6. CML outputs require 50  $\Omega$  receiver termination resistors to  $V_{CC}$  for proper operation.
7. Input and output parameters vary 1:1 with  $V_{CC}$ .
8.  $V_{th}$  is applied to the complementary input when operating in single-ended mode.
9.  $V_{CMR(MIN)}$  varies 1:1 with  $V_{EE}$ ,  $V_{CMR(MAX)}$  varies 1:1 with  $V_{CC}$ .

# NB7L111M

**Table 6. AC CHARACTERISTICS**  $V_{CC} = 2.375\text{ V to }2.625\text{ V}$  and  $3.135\text{ V to }3.465\text{ V}$ ,  $V_{EE} = 0\text{ V}$ ; (Note 10)

Symbol	Characteristic	-40 °C			25 °C			85 °C			Unit
		Min	Typ	Max	Min	Typ	Max	Min	Typ	Max	
$V_{OUTPP}$	Output Voltage Amplitude (@ $V_{inppmin}$ ) (See Figures 3, 4, 5, and 6) $V_{CC} = 2.375\text{ V to }2.625\text{ V}$ $f_{in} \leq 3\text{ GHz}$ $f_{in} \leq 5.5\text{ GHz}$ $V_{CC} = 3.135\text{ V to }3.465\text{ V}$ $f_{in} \leq 3\text{ GHz}$ $f_{in} \leq 5.5\text{ GHz}$	240 115	330 220		240 115	330 220		240 115	330 220		mV
$f_{DATA}$	Maximum Operating Data Rate	5	6		5	6		5	6		Gb/s
$t_{PLH}$ , $t_{PHL}$	Differential Input-to-Output Propagation Delay @ 1 GHz (See Figures 7 and 11) CLK-Q SEL-Q	200 290	240 340	280 390	200 290	240 340	280 390	200 290	240 340	280 390	ps
$t_{SKEW}$	Duty Cycle Skew (Note 11) Within Device Skew Device-to-Device Skew (Note 15)		2 10 15	15 20 80		2 10 15	15 20 80		2 10 15	15 20 80	ps
$t_{JITTER}$	RMS Random Clock Jitter (Note 13) $f_{in} = 3\text{ GHz}$ $f_{in} = 5.5\text{ GHz}$ Peak-to-Peak Data Dependent Jitter (Note 14) $f_{DATA} = 3.125\text{ Gb/s}$ $f_{DATA} = 5\text{ Gb/s}$ $f_{DATA} = 6.125\text{ Gb/s}$		0.2 0.2 6 15 15	0.5 0.5 15 25 25		0.2 0.2 6 15 15	0.5 0.5 15 25 25		0.2 0.2 6 15 15	0.5 0.5 15 25 25	ps
$V_{INPP}$	Input Voltage Swing/Sensitivity (Differential Configuration) (Note 12 and Figures 3, 4, 5, and 6)	75	400	2500	75	400	2500	75	400	2500	mV
$t_r$ , $t_f$	Output Rise/Fall Times @ 1 GHz (20% - 80%)		50	75		50	75		50	75	ps

NOTE: Device will meet the specifications after thermal equilibrium has been established when mounted in a test socket or printed circuit board with maintained transverse airflow greater than 500 lfpm. Electrical parameters are guaranteed only over the declared operating temperature range. Functional operation of the device exceeding these conditions is not implied. Device specification limit values are applied individually under normal operating conditions and not valid simultaneously.

10. Measured by forcing  $V_{INPP(MIN)}$  from a 50% duty cycle clock source. All loading with an external  $R_L = 50\ \Omega$  to  $V_{CC}$ . Input edge rates 40 ps (20% - 80%).

11. Duty cycle skew is measured between differential outputs using the deviations of the sum of  $T_{pw-}$  and  $T_{pw+}$  @ 1 GHz.

12.  $V_{INPP(MAX)}$  cannot exceed  $V_{CC} - V_{EE}$ . Input voltage swing is a single-ended measurement operating in differential mode.

13. Additive RMS jitter with 50% duty cycle clock signal.

14. Additive peak-to-peak data dependent jitter with input NRZ data at PRBS 2<sup>23</sup>-1.

15. Device-to-device skew is measured between outputs under identical transition and conditions @ 1 GHz.

# NB7L111M

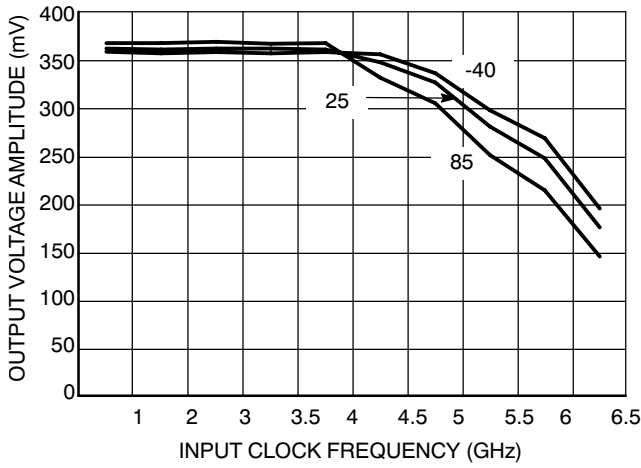

**Figure 3. Output Voltage Amplitude vs. Input Clock Frequency and Temperature**  
 $(V_{inpp} = 400 \text{ mV}; V_{CC} = 3.3 \text{ V})$

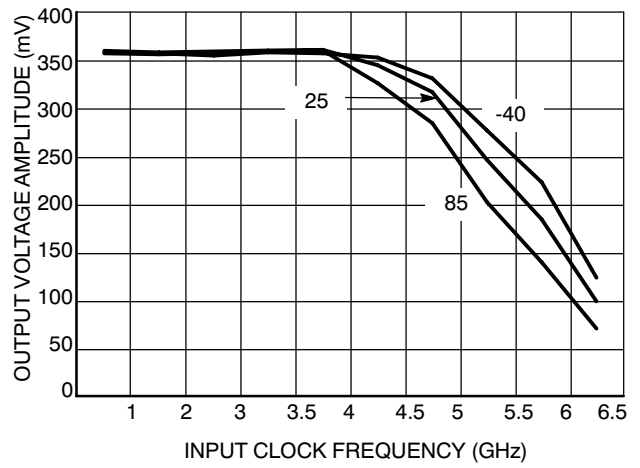

**Figure 4. Output Voltage Amplitude vs. Input Clock Frequency and Temperature**  
 $(V_{inpp} = 75 \text{ mV}; V_{CC} = 3.3 \text{ V})$

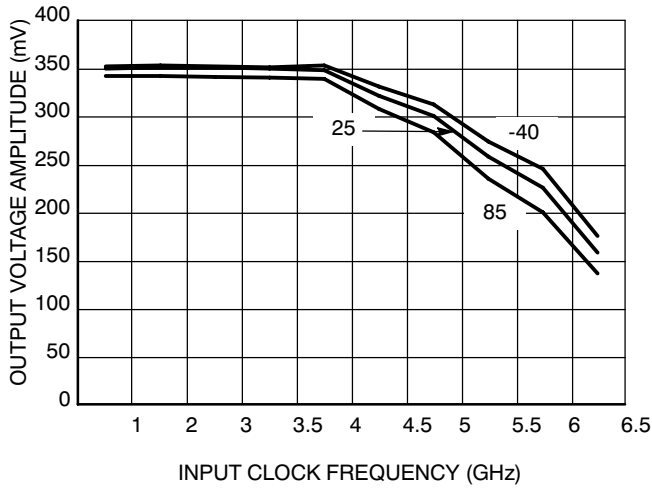

**Figure 5. Output Voltage Amplitude vs. Input Clock Frequency and Temperature**  
 $(V_{inpp} = 400 \text{ mV}; V_{CC} = 2.5 \text{ V})$

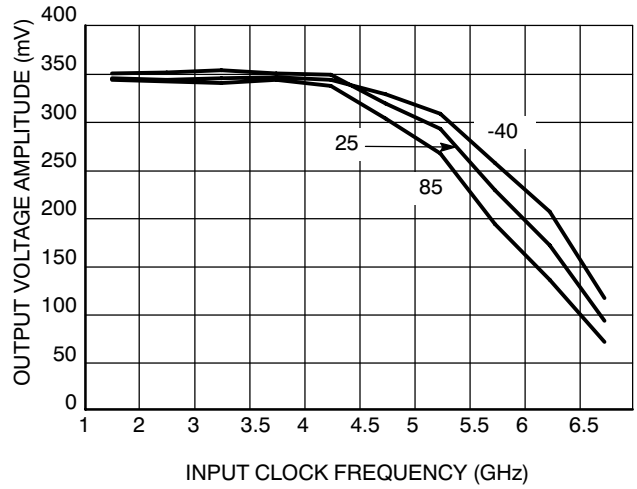

**Figure 6. Output Voltage Amplitude vs. Input Clock Frequency and Temperature**  
 $(V_{inpp} = 75 \text{ mV}; V_{CC} = 2.5 \text{ V})$

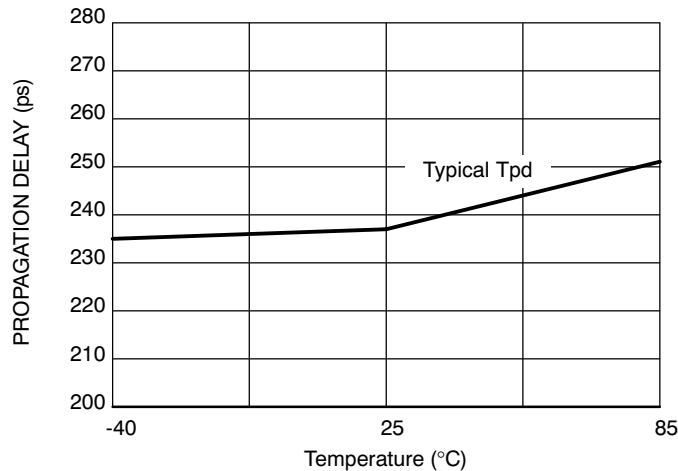

**Figure 7. Propagation Delay versus Temperature**

# NB7L111M

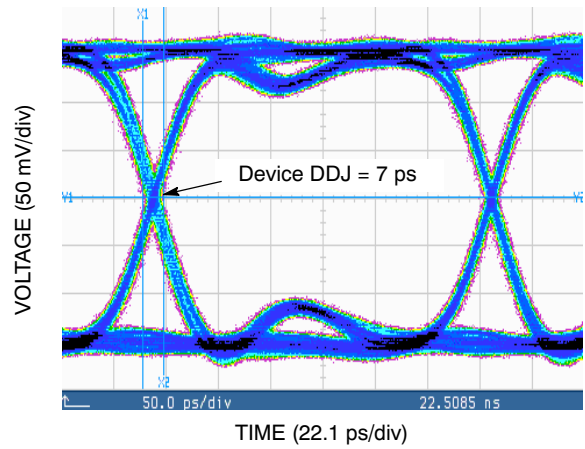
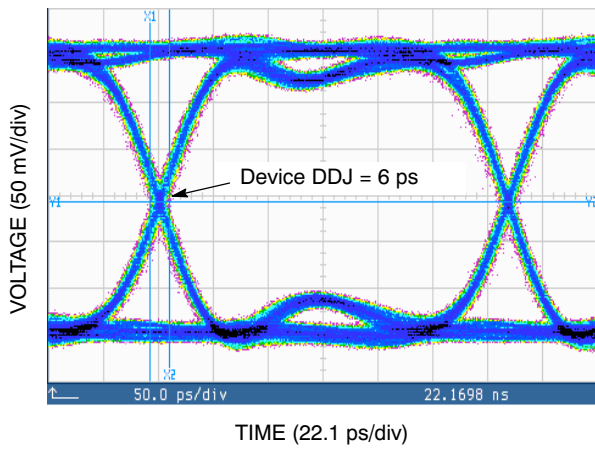

Figure 8. Typical Output Waveform at 3.125 Gb/s with PRBS 2<sup>23</sup>-1 ( $V_{inpp} = 75$  mV-left and 400 mV-right)

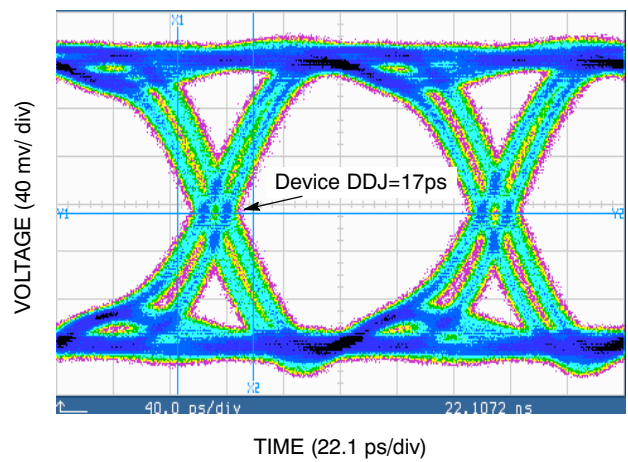
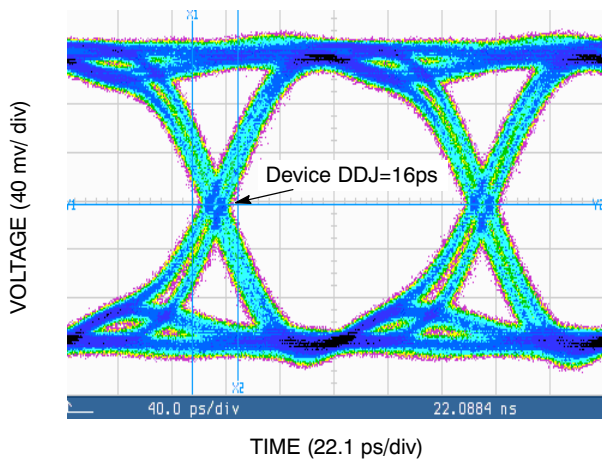

Figure 9. Typical Output Waveform at 5 Gb/s with PRBS 2<sup>23</sup>-1 ( $V_{inpp}=75$  mV-left and 400 mV-right)

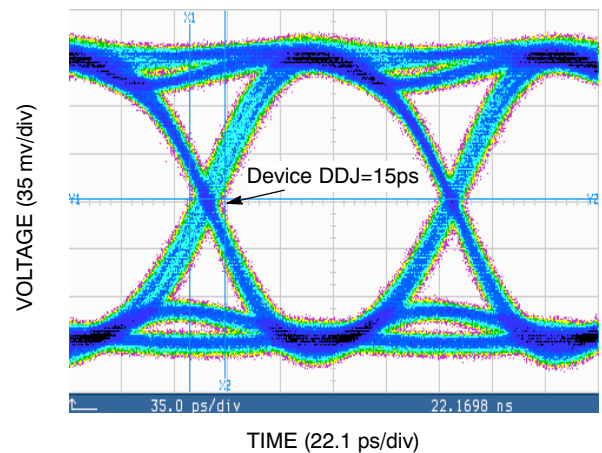
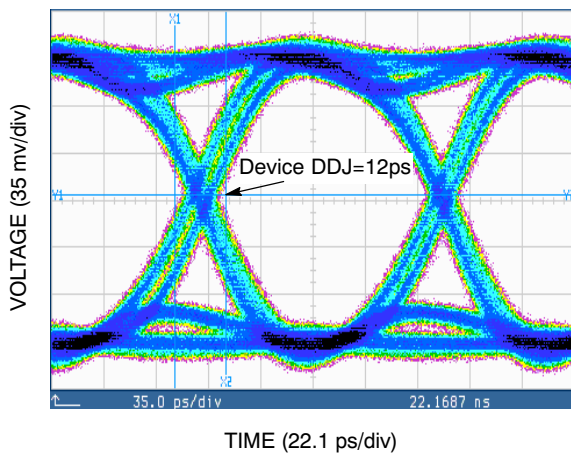

Figure 10. Typical Output Waveform at 6.125 Gb/s with PRBS 2<sup>23</sup>-1 ( $V_{inpp} = 75$  mV-left and 400 mV-right)



# NB7L111M

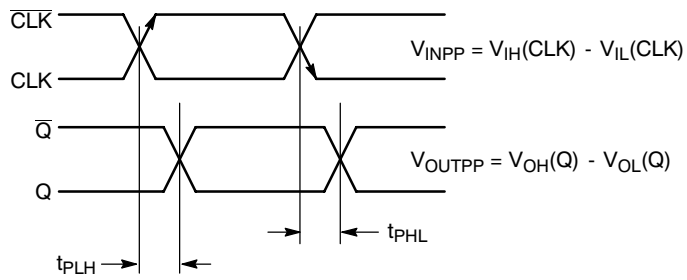

Figure 11. AC Reference Measurement

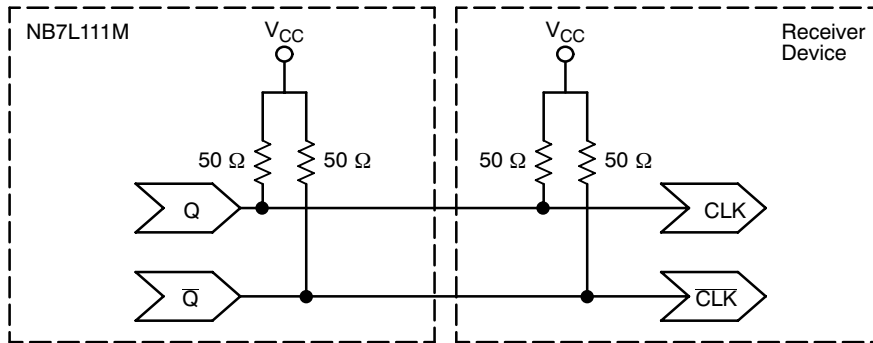

Figure 12. Typical Termination for 16 mA Output Drive and Device Evaluation

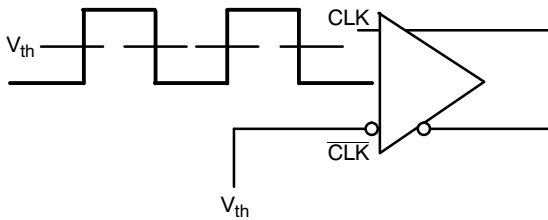

Figure 13. Differential Input Driven Single-Ended

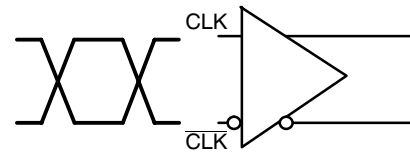

Figure 14. Differential Inputs Driven Differentially

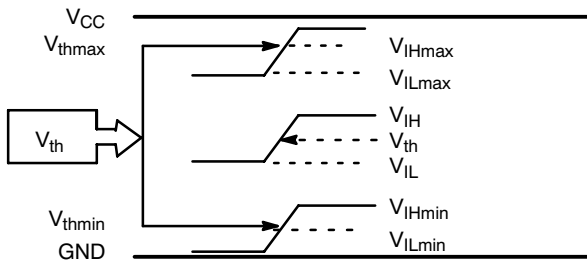

Figure 15.  $V_{th}$  Diagram

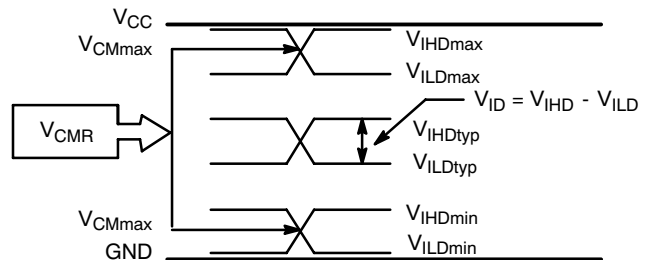

Figure 16.  $V_{CMR}$  Diagram

## NB7L111M

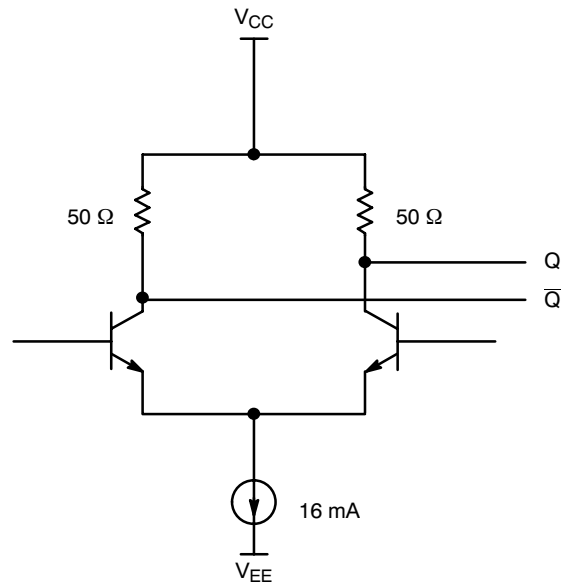

Figure 17. CML Output Structure

Table 7. Interfacing Options

INTERFACING OPTIONS	CONNECTIONS
CML	Connect VTCLK0, $\overline{\text{VTCLK0}}$ , VTCLK1, $\overline{\text{VTCLK1}}$ , VTSEL, $\overline{\text{VTSEL}}$ to V <sub>CC</sub>
LVDS	Connect VTCLK0, $\overline{\text{VTCLK0}}$ together for CLK0 input; Connect VTCLK1, $\overline{\text{VTCLK1}}$ together for CLK1 input; Connect VTSEL, $\overline{\text{VTSEL}}$ together for SEL control input.
AC-COUPLED	Bias VTCLK0, $\overline{\text{VTCLK0}}$ , VTSEL, $\overline{\text{VTSEL}}$ and VTCLK1, $\overline{\text{VTCLK1}}$ inputs within (VCMR) Common Mode Range.
RSECL, LVPECL	Standard ECL termination techniques. See AND8020.
LVTTL, LVCMOS	An external voltage should be applied to the unused complementary differential input. Nominal voltage 1.5 V for LVTTL and V <sub>CC</sub> /2 for LVCMOS inputs.

# NB7L111M

## Application Information

All NB7L111M inputs can accept PECL, CML, LVTTTL, LVCMOS and LVDS signal levels. The limitations for differential input signal (LVDS, PECL, or CML) are

minimum input swing of 100 mV and the maximum input swing of 450 mV. Within these conditions, the input voltage can range from  $V_{CC}$  to 1.2 V. Examples interfaces are illustrated below in a 50  $\Omega$  environment ( $Z = 50 \Omega$ ).

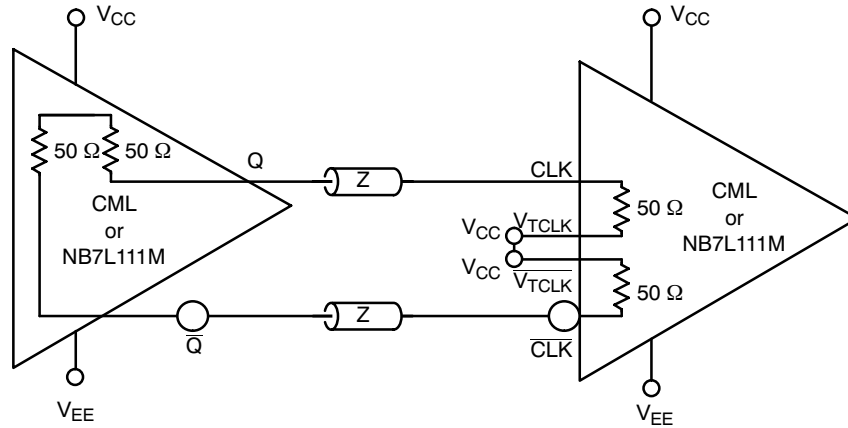

Figure 18. CML to CML Interface

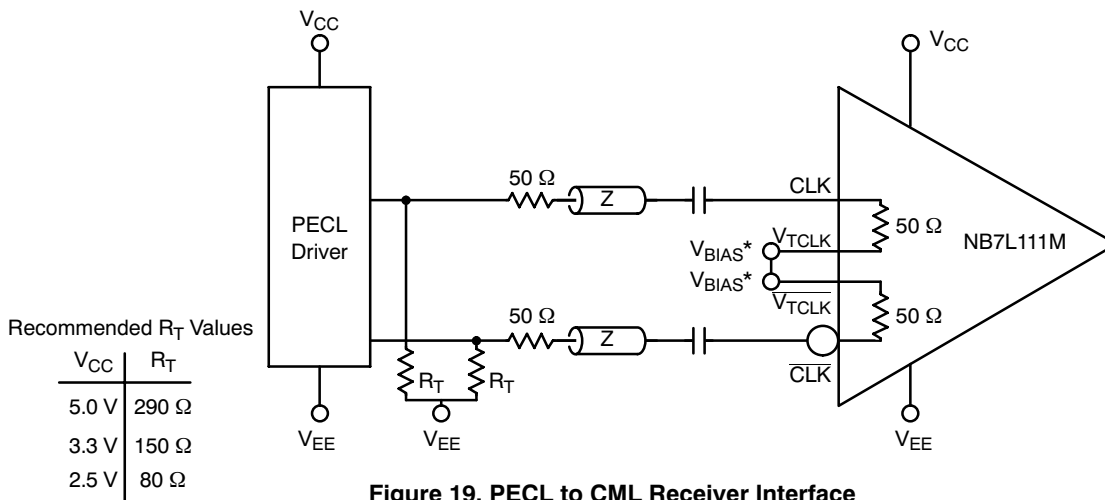

Figure 19. PECL to CML Receiver Interface

\* $V_{BIAS}$  is within  $V_{CMR}$  Range.

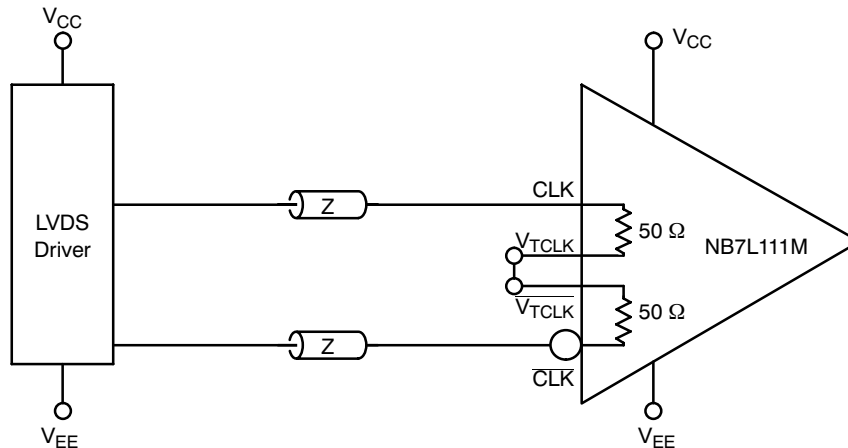
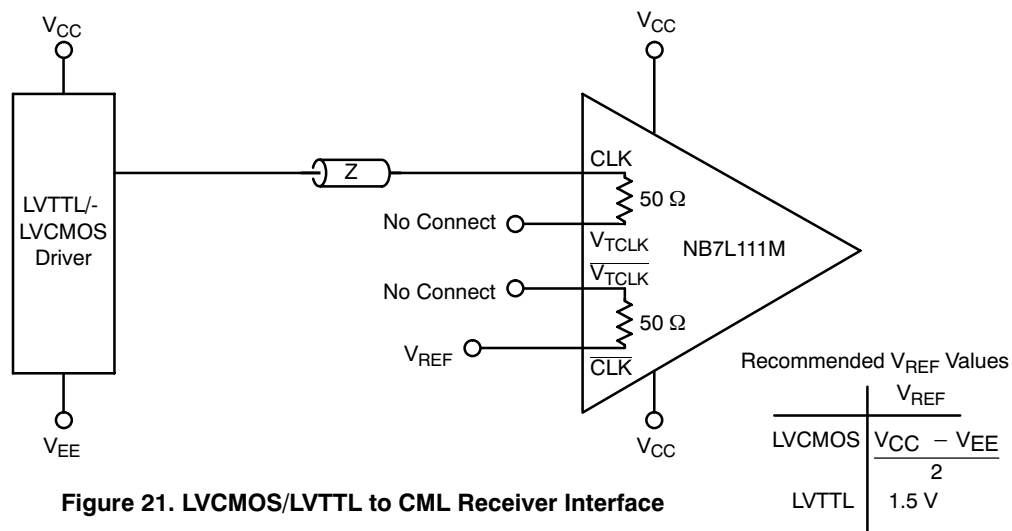

Figure 20. LVDS to CML Receiver Interface

# NB7L111M



## ORDERING INFORMATION

Device	Package	Shipping <sup>†</sup>
NB7L111MMN	QFN-52	260 Units / Tray
NB7L111MMNG	QFN-52 (Pb-Free)	260 Units / Tray
NB7L111MMNR2	QFN-52	2000 / Tape & Reel
NB7L111MMNR2G	QFN-52 (Pb-Free)	2000 / Tape & Reel

<sup>†</sup>For information on tape and reel specifications, including part orientation and tape sizes, please refer to our Tape and Reel Packaging Specifications Brochure, BRD8011/D.

# NB7L111M

## PACKAGE DIMENSIONS

52 PIN QFN 8x8  
CASE 485M-01  
ISSUE A

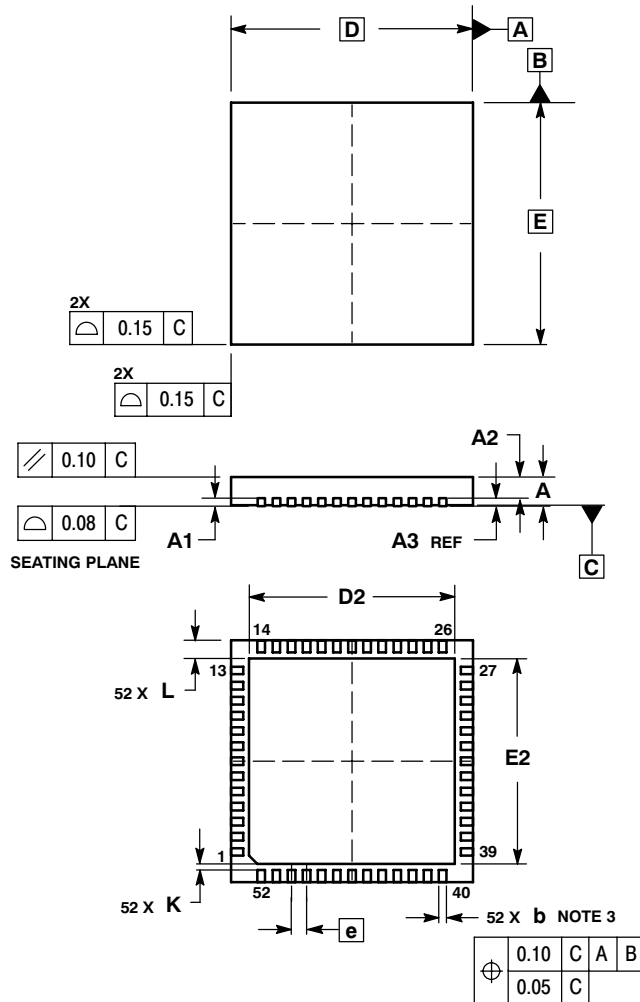

- NOTES:
1. DIMENSIONING AND TOLERANCING PER ASME Y14.5M, 1994.
  2. CONTROLLING DIMENSION: MILLIMETERS
  3. DIMENSION b APPLIES TO PLATED TERMINAL AND IS MEASURED BETWEEN 0.25 AND 0.30 MM FROM TERMINAL.
  4. COPLANARITY APPLIES TO THE EXPOSED PAD AS WELL AS THE TERMINALS.

DIM	MILLIMETERS	
	MIN	MAX
A	0.80	1.00
A1	0.00	0.05
A2	0.60	0.80
A3	0.20	REF
b	0.18	0.30
D	8.00	BSC
D2	6.50	6.80
E	8.00	BSC
E2	6.50	6.80
e	0.50	BSC
K	0.20	--
L	0.30	0.50

GigaComm is a trademark of Semiconductor Components Industries, LLC (SCILLC).

**ON Semiconductor** and  are registered trademarks of Semiconductor Components Industries, LLC (SCILLC). SCILLC reserves the right to make changes without further notice to any products herein. SCILLC makes no warranty, representation or guarantee regarding the suitability of its products for any particular purpose, nor does SCILLC assume any liability arising out of the application or use of any product or circuit, and specifically disclaims any and all liability, including without limitation special, consequential or incidental damages. "Typical" parameters which may be provided in SCILLC data sheets and/or specifications can and do vary in different applications and actual performance may vary over time. All operating parameters, including "Typicals" must be validated for each customer application by customer's technical experts. SCILLC does not convey any license under its patent rights nor the rights of others. SCILLC products are not designed, intended, or authorized for use as components in systems intended for surgical implant into the body, or other applications intended to support or sustain life, or for any other application in which the failure of the SCILLC product could create a situation where personal injury or death may occur. Should Buyer purchase or use SCILLC products for any such unintended or unauthorized application, Buyer shall indemnify and hold SCILLC and its officers, employees, subsidiaries, affiliates, and distributors harmless against all claims, costs, damages, and expenses, and reasonable attorney fees arising out of, directly or indirectly, any claim of personal injury or death associated with such unintended or unauthorized use, even if such claim alleges that SCILLC was negligent regarding the design or manufacture of the part. SCILLC is an Equal Opportunity/Affirmative Action Employer. This literature is subject to all applicable copyright laws and is not for resale in any manner.

### PUBLICATION ORDERING INFORMATION

**LITERATURE FULFILLMENT:**  
Literature Distribution Center for ON Semiconductor  
P.O. Box 5163, Denver, Colorado 80217 USA  
**Phone:** 303-675-2175 or 800-344-3860 Toll Free USA/Canada  
**Fax:** 303-675-2176 or 800-344-3867 Toll Free USA/Canada  
**Email:** orderlit@onsemi.com

**N. American Technical Support:** 800-282-9855 Toll Free  
USA/Canada  
**Europe, Middle East and Africa Technical Support:**  
Phone: 421 33 790 2910  
**Japan Customer Focus Center**  
Phone: 81-3-5773-3850

**ON Semiconductor Website:** [www.onsemi.com](http://www.onsemi.com)  
**Order Literature:** <http://www.onsemi.com/orderlit>

For additional information, please contact your local Sales Representative

NB7L111M/D