

3V/5V, 6dB Video Amplifiers with High Output-Current Capability

General Description

The MAX9504A/MAX9504B 3V/5V, ground-sensing amplifiers with a fixed gain of 6dB provide high output current while consuming only 10nA of current in shutdown mode. The MAX9504A/MAX9504B are ideal for amplifying DC-coupled video inputs from current digital-to-analog converters (DACs). The output can drive two DC-coupled 150Ω back-terminated video loads in portable media players, security cameras, and automotive video applications. The MAX9504B features an internal 160mV input offset to prevent output sync tip clipping when the input signal is close to ground.

The MAX9504A/MAX9504B have -3dB large-signal bandwidth of 42MHz and -3dB small-signal bandwidth of 47MHz.

The MAX9504A/MAX9504B operate from a single +2.7V to +5.5V supply and consume only 5mA of supply current. The low-power shutdown mode reduces supply current to 10nA, making the MAX9504A/MAX9504B ideal for low-voltage, battery-powered video applications.

The MAX9504A/MAX9504B are available in tiny 6-pin μDFN (2mm x 2mm) and 6-pin SOT23 packages, and are specified over the -40°C to +85°C extended temperature range.

Applications

- Car Navigation Systems
- Security Cameras
- Portable Media Players
- Low-Power Video Applications
- Y/C-to-CVBS Mixer

Pin Configurations

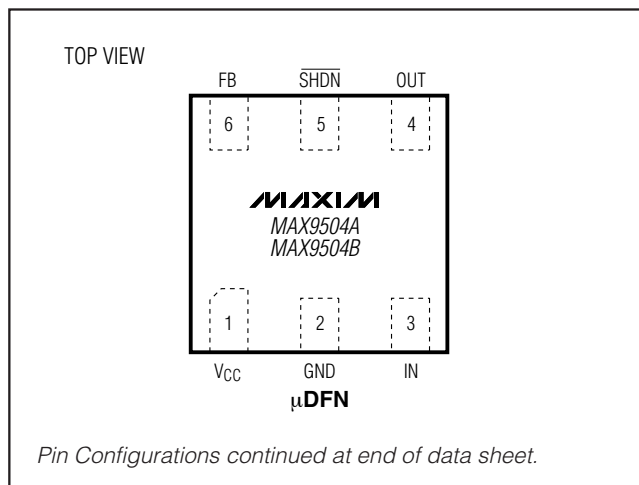

Features

- ◆ DC-Coupled Input/Output
- ◆ Drives Two DC-Coupled Video Loads
- ◆ Direct Connection to Ground-Referenced DAC
- ◆ 42MHz Large-Signal Bandwidth
- ◆ 47MHz Small-Signal Bandwidth
- ◆ Internal 160mV Input Offset (MAX9504B)
- ◆ Single-Supply Operation from +2.7V to +5.5V
- ◆ 10nA Shutdown Supply Current
- ◆ Small μDFN (2mm x 2mm) and SOT23 Packages

Ordering Information

PART	PIN-PACKAGE	PKG CODE	OFFSET (mV)	TOP MARK
MAX9504AELT-T	6 μDFN-6	L622-1	0	AAJ
MAX9504AEUT+T	6 SOT23-6	U65-3	0	ABWC
MAX9504BELT-T	6 μDFN-6	L622-1	160	AAK
MAX9504BEUT+	6 SOT23-6	U65-3	160	ABWD

Note: All devices specified over the -40°C to +85°C operating range.

+Denotes lead-free package.

Block Diagram

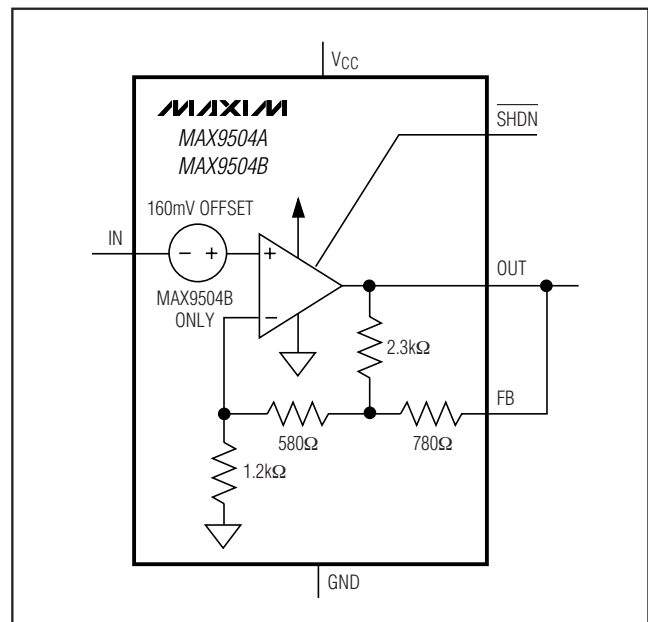

3V/5V, 6dB Video Amplifiers with High Output-Current Capability

ABSOLUTE MAXIMUM RATINGS

V_{CC} to GND-0.3V to +6V
 IN, OUT, FB, $\overline{\text{SHDN}}$ to GND-0.3V to (V_{CC} + 0.3V)
 OUT Short-Circuit Duration to V_{CC} or GNDContinuous
 Continuous Power Dissipation (T_A = +70°C)
 6-Pin SOT23 (derate 8.7mW/°C above +70°C).....695mW
 6-Pin μ DFN (derate 4.7mW/°C above +70°C)377mW

Operating Temperature Range-40°C to +85°C
 Junction Temperature+150°C
 Storage Temperature Range-65°C to +150°C
 Lead Temperature (soldering, 10s)+300°C

Stresses beyond those listed under "Absolute Maximum Ratings" may cause permanent damage to the device. These are stress ratings only, and functional operation of the device at these or any other conditions beyond those indicated in the operational sections of the specifications is not implied. Exposure to absolute maximum rating conditions for extended periods may affect device reliability.

DC ELECTRICAL CHARACTERISTICS

(V_{CC} = 3.0V, GND = 0V, V_{IN} = 0.5V, R_L = infinity to GND, FB connected to OUT, $\overline{\text{SHDN}}$ = V_{CC}, T_A = -40°C to +85°C. Typical values are at T_A = +25°C, unless otherwise noted.) (Note 1)

PARAMETER	SYMBOL	CONDITIONS		MIN	TYP	MAX	UNITS
Supply Voltage Range	V _{CC}	Guaranteed by PSRR		2.7		5.5	V
Quiescent Supply Current	I _{CC}	V _{CC} = 3V			5	9	mA
		V _{CC} = 5V			5	9	
Shutdown Supply Current	I $\overline{\text{SHDN}}$	$\overline{\text{SHDN}}$ = 0V			0.01	1	μ A
Input Voltage Range	V _{IN}	Inferred from voltage gain	MAX9504A	0.10		1.25	V
			MAX9504B	0		1.10	
Input Offset Voltage	V _{OS}	MAX9504A		-25	0	+25	mV
		MAX9504B		120	160	200	
Input Bias Current	I _{BIAS}	V _{IN} = 0V			5	20	μ A
Input Resistance	R _{IN}	0 < V _{IN} < 1.45V			4		M Ω
Voltage Gain	A _v	R _L = 150 Ω (Note 2), MAX9504A	V _{CC} = 2.7V, 0.1V < V _{IN} < 1.10V	1.9	2.0	2.1	V/V
			V _{CC} = 3.0V, 0.1V < V _{IN} < 1.25V	1.9	2.0	2.1	
			V _{CC} = 4.5V, 0.1V < V _{IN} < 1.90V		2		
		R _L = 150 Ω (Note 2), MAX9504B	V _{CC} = 2.7V, 0 < V _{IN} < 0.95V	1.9	2.0	2.1	
			V _{CC} = 3.0V, 0 < V _{IN} < 1.10V	1.9	2.0	2.1	
			V _{CC} = 4.5V, 0 < V _{IN} < 1.75V		2		
Power-Supply Rejection Ratio	PSRR	2.7V < V _{CC} < 5.5V		MAX9504A	60	80	dB
				MAX9504B	50	61	
Output Current	I _{OUT}	Sourcing, R _L = 20 Ω to GND		45	85	mA	
		Sinking, R _L = 20 Ω to V _{CC}		40	110		
Output Short-Circuit Current	I _{SC}	OUT shorted to V _{CC} or GND			130	mA	
$\overline{\text{SHDN}}$ Logic-Low Threshold	V _{IL}					V _{CC} x 0.3	V
$\overline{\text{SHDN}}$ Logic-High Threshold	V _{IH}			V _{CC} x 0.7			V
$\overline{\text{SHDN}}$ Input Current	I _{IN}	$\overline{\text{SHDN}}$ = 0V or V _{CC}			0.003	1.000	μ A
Shutdown Output Impedance	R _{OUT} (Disabled)	$\overline{\text{SHDN}}$ = 0V			4		k Ω

3V/5V, 6dB Video Amplifiers with High Output-Current Capability

MAX9504A/MAX9504B

AC ELECTRICAL CHARACTERISTICS

($V_{CC} = 3.0V$, $GND = 0V$, $V_{IN} = 0.5V$, $R_L = 150\Omega$ to GND, FB connected to OUT, $\overline{SHDN} = V_{CC}$, $T_A = +25^\circ C$, unless otherwise noted.)

PARAMETER	SYMBOL	CONDITIONS		MIN	TYP	MAX	UNITS
Small-Signal -3dB Bandwidth	BW _{SS}	$V_{OUT} = 100mV_{P-P}$			47		MHz
Large-Signal -3dB Bandwidth	BW _{LS}	$V_{OUT} = 2V_{P-P}$			42		MHz
Small-Signal 0.1dB Gain Flatness	BW _{0.1dBSS}	$V_{OUT} = 100mV_{P-P}$			10		MHz
Large-Signal 0.1dB Gain Flatness	BW _{0.1dBLS}	$V_{OUT} = 2V_{P-P}$			12		MHz
Slew Rate	SR	$V_{OUT} = 2V$ step			165		V/ μs
Settling Time to 1%	t _s	$V_{OUT} = 2V$ step			25		ns
Power-Supply Rejection Ratio	PSRR	f = 100kHz	MAX9504A		75		dB
			MAX9504B		49		
Output Impedance	Z _{OUT}	f = 5MHz			2.5		Ω
Differential Gain	DG	NTSC	$V_{CC} = 3V$		0.1		%
			$V_{CC} = 5V$		0.1		
Differential Phase	DP	NTSC	$V_{CC} = 3V$		0.3		degrees
			$V_{CC} = 5V$		0.3		
2T Pulse-to-Bar K Rating		2T = 250ns, bar time is 18 μs , the beginning 2.5% and the ending 2.5% of the bar time are ignored			0.2		K%
2T Pulse Response		2T = 250ns			0.1		K%
2T Bar Response		2T = 250ns, bar time is 18 μs , the beginning 2.5% and the ending 2.5% of the bar time are ignored			0.1		K%
Nonlinearity		5-step staircase			0.1		%
Group Delay Distortion	D/dT	f = 100kHz to 5.5MHz			2		ns
Peak Signal-to-RMS Noise	SNR	$V_{IN} = 1V_{P-P}$, 100kHz < f < 5MHz			65		dB
Enable Time	t _{ON}	$V_{IN} = 1V$, V_{OUT} settled to 1% of nominal			300		ns
Disable Time	t _{OFF}	$V_{IN} = 1V$, V_{OUT} settled to 1% of nominal			85		ns

Note 1: All devices are 100% production tested at $T_A = +25^\circ C$. Specifications over temperature limits are guaranteed by design.

Note 2: Voltage gain (A_V) is referenced to the input offset voltage; i.e., an input voltage of V_{IN} would produce an output voltage of $V_{OUT} = A_V \times (V_{IN} + V_{OS})$.

3V/5V, 6dB Video Amplifiers with High Output-Current Capability

Typical Operating Characteristics

($V_{CC} = 3.0V$, $GND = 0V$, $V_{IN} = 0.5V$, $R_L = 150\Omega$ to GND , FB connected to OUT , $\overline{SHDN} = V_{CC}$, $T_A = +25^\circ C$, unless otherwise noted.)

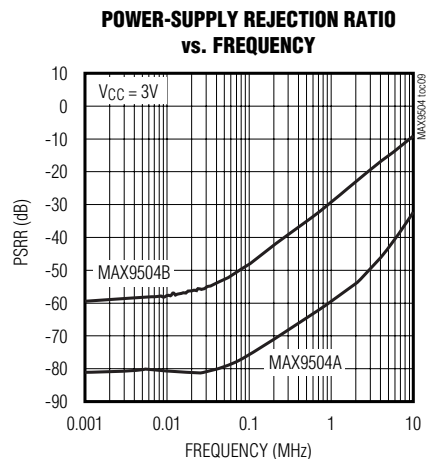
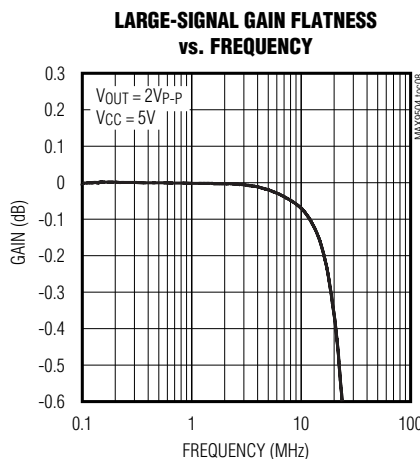
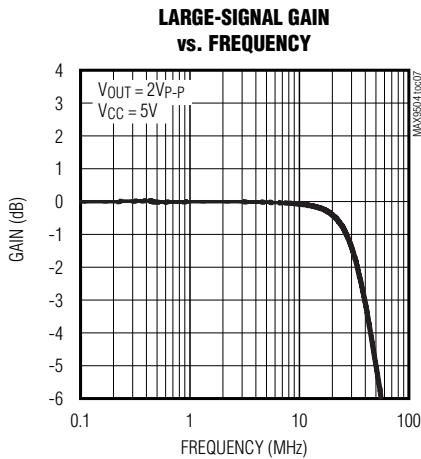
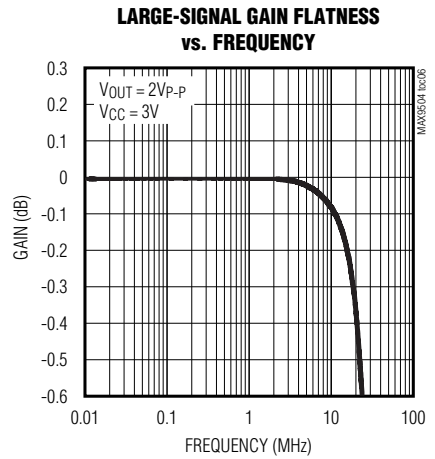
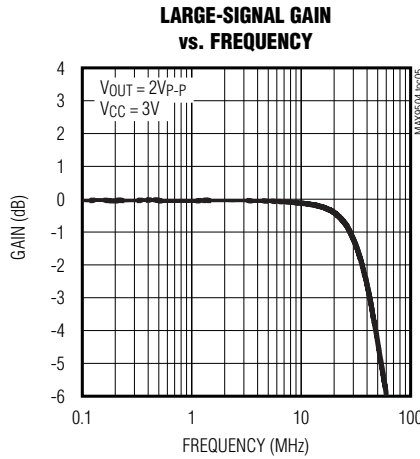
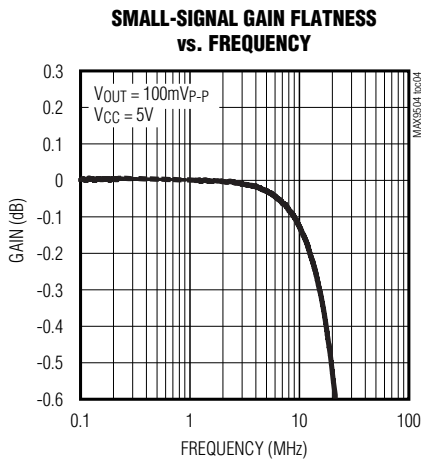
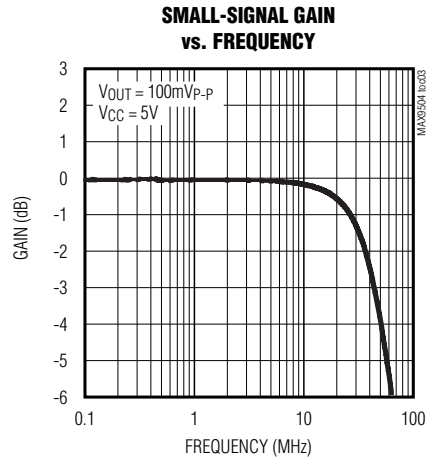
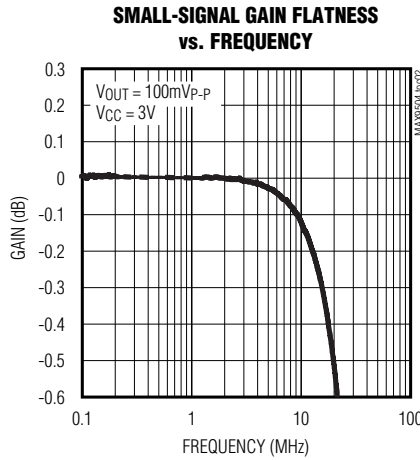
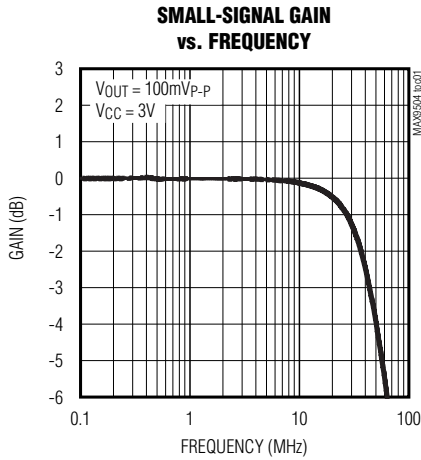

3V/5V, 6dB Video Amplifiers with High Output-Current Capability

Typical Operating Characteristics (continued)

($V_{CC} = 3.0V$, $GND = 0V$, $V_{IN} = 0.5V$, $R_L = 150\Omega$ to GND , FB connected to OUT , $\overline{SHDN} = V_{CC}$, $T_A = +25^\circ C$, unless otherwise noted.)

MAX9504A/MAX9504B

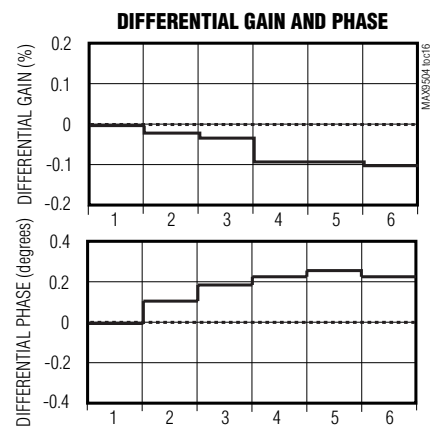
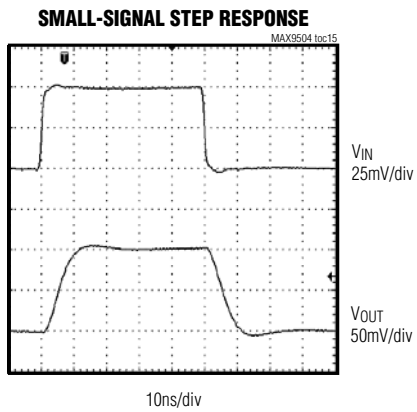
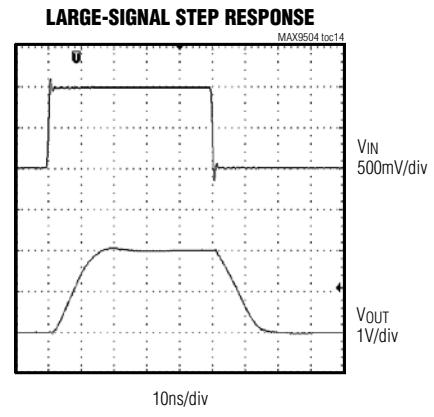
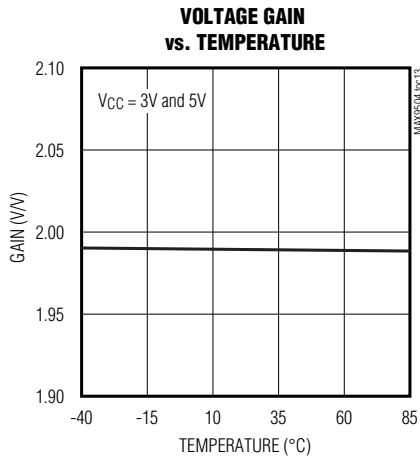
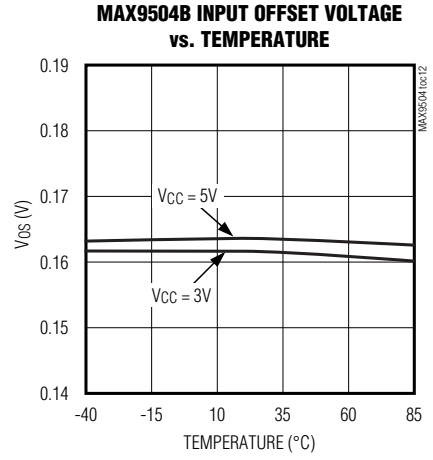
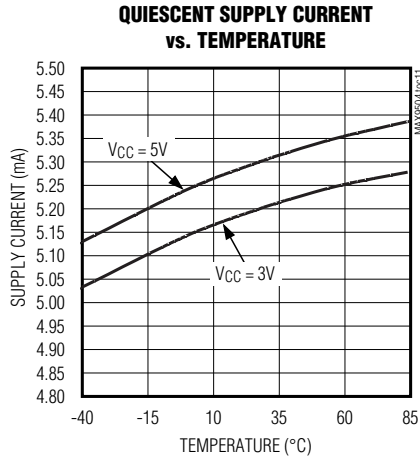
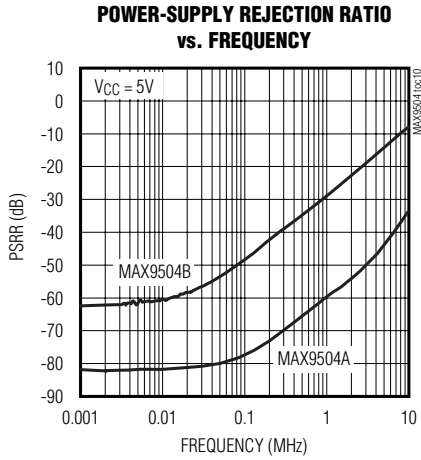

3V/5V, 6dB Video Amplifiers with High Output-Current Capability

Typical Operating Characteristics (continued)

($V_{CC} = 3.0V$, $GND = 0V$, $V_{IN} = 0.5V$, $R_L = 150\Omega$ to GND , FB connected to OUT , $\overline{SHDN} = V_{CC}$, $T_A = +25^\circ C$, unless otherwise noted.)

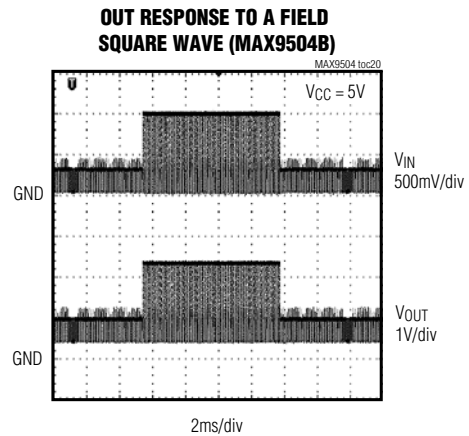
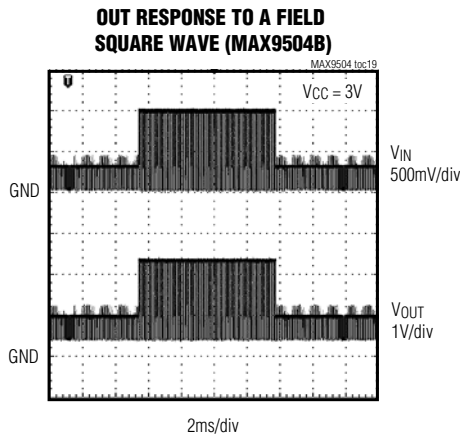
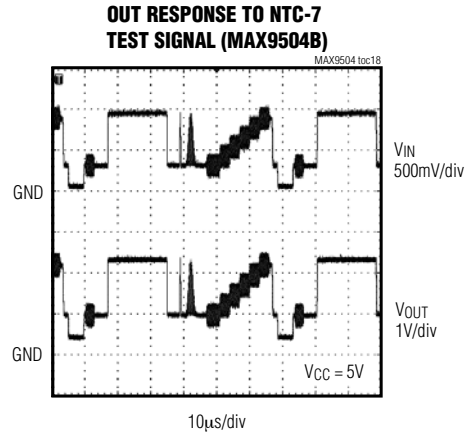
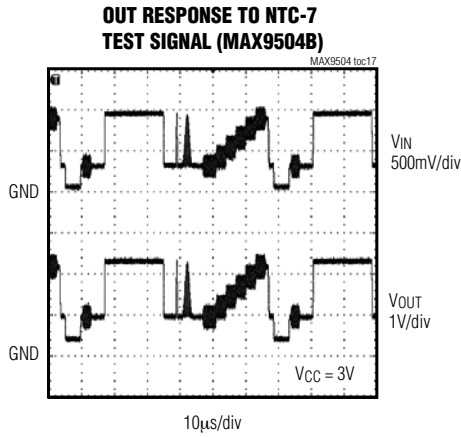

Pin Description

PIN		NAME	FUNCTION
SOT23	µDFN		
1	4	OUT	Video Output
2	2	GND	Ground
3	3	IN	Video Input
4	1	V_{CC}	Power-Supply Input. Bypass V_{CC} with a 0.1µF capacitor to ground as close as possible to V_{CC} .
5	5	\overline{SHDN}	Shutdown Input. Pull \overline{SHDN} low to place the device in low-power shutdown mode.
6	6	FB	Feedback. Connect FB to OUT.

3V/5V, 6dB Video Amplifiers with High Output-Current Capability

Typical Application Circuit

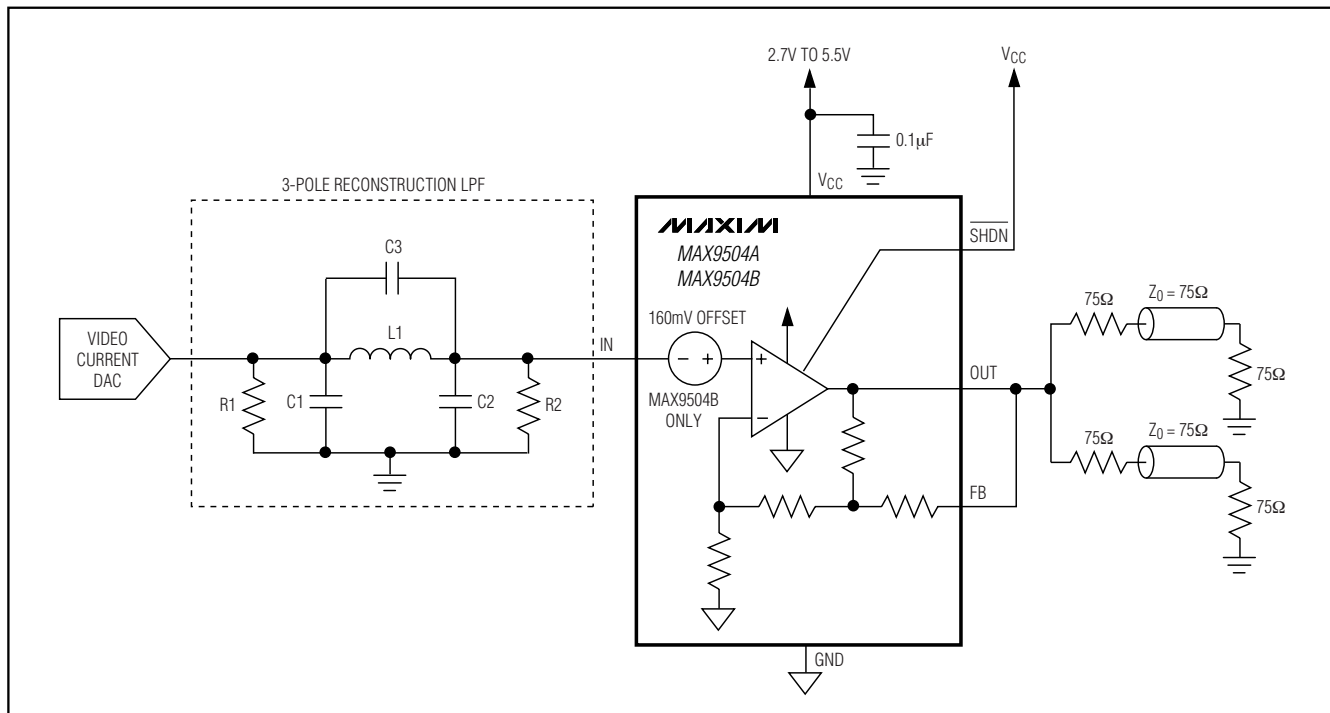

MAX9504A/MAX9504B

Detailed Description

The MAX9504A/MAX9504B 3V/5V, 6dB video amplifiers with low-power shutdown mode accept DC-coupled inputs and drive up to two DC-coupled, 150Ω back-terminated video loads. The MAX9504B provides an internal input offset voltage of 160mV, which allows DC-coupled input signals down to ground without clipping the output sync tip.

The MAX9504A/MAX9504B operate from a single +2.7V to +5.5V supply and consume only 5mA of supply current. The low-power shutdown mode reduces supply current to less than 1µA, making the MAX9504A/MAX9504B ideal for low-voltage, battery-powered video applications.

Output Current Capability

As shown in the *Typical Application Circuit*, the MAX9504A/MAX9504B can drive up to two 150Ω loads to ground at the same time because the outputs can source guaranteed 45mA (min) current. Two 150Ω loads to ground is the same as a single 75Ω load to ground.

Since the MAX9504A/MAX9504B can also sink guaranteed 40mA (min) current, they can also drive two, AC-coupled 150Ω loads. When $V_{CC} > 3V$, the output can swing 2.4V_{P-P}. When $V_{CC} > 4.5V$, the output can swing 2.8V_{P-P}.

Input Offset (MAX9504B)

The MAX9504A/MAX9504B amplify DC-coupled video signals with a gain of +2V/V (+6dB). The MAX9504B features a 160mV input offset voltage (V_{OS}) that allows a video signal input range to ground without clipping the output sync tip. The MAX9504B output voltage is the sum of the input voltage and the input offset voltage gained up by a factor of 2.

$$V_{OUT} = 2 \times (V_{IN} + V_{OS})$$

For example, if $V_{IN} = 1V$ and $V_{OS} = 0.16V$ then:

$$V_{OUT} = 2 \times (1V + 0.16V) = 2.32V$$

Shutdown Mode

The MAX9504A/MAX9504B feature a low-power shutdown mode ($I_{SHDN} < 1\mu A$) for battery-powered/portable applications. Driving \overline{SHDN} high enables the output. Driving \overline{SHDN} low disables the output and places the MAX9504A/MAX9504B into a low-power shutdown mode. In shutdown, the output resistance is 4kΩ (typ) due to the combination of feedback resistors from OUT to ground with FB connected to OUT.

3V/5V, 6dB Video Amplifiers with High Output-Current Capability

Applications Information

Using the MAX9504A/MAX9504B with Video Current DACs

Video current DACs source current into a resistor connected to ground. The output voltage range for composite video and luma (Y) is usually from ground up to 1V (see Figure 1). Notice that the sync tip is quite close to ground. Standard single-supply amplifiers with rail-to-rail outputs have difficulty amplifying input signals at or near ground because their output stages enter a nonlinear mode of operation when the output is pulled close to ground.

The MAX9504B level shifts the input signal up by 160mV so that the output has a positive DC offset of

320mV. As a result, the MAX9504B output stage always operates in the linear mode. Even if the input signal is at ground, the MAX9504B output is at 320mV.

At the output of a video current DAC, the blank level of the chroma signal is usually between 500mV to 650mV. The voltage swing above and below the blank level is approximately $\pm 350\text{mV}$ (see Figure 1). If the blank level is 550mV, then the lowest voltage for the chroma signal is 200mV. For the case of chroma signals, no input level shift is needed because 200mV gained up by two is 400mV, which is well within the linear output range of the MAX9504A or MAX9504B. Since the MAX9504A does not have an input level shift, the MAX9504A should be used with chroma signals. In summary, use the MAX9504B with composite video and luma signals from a DAC, and use the MAX9504A with chroma signals from a DAC.

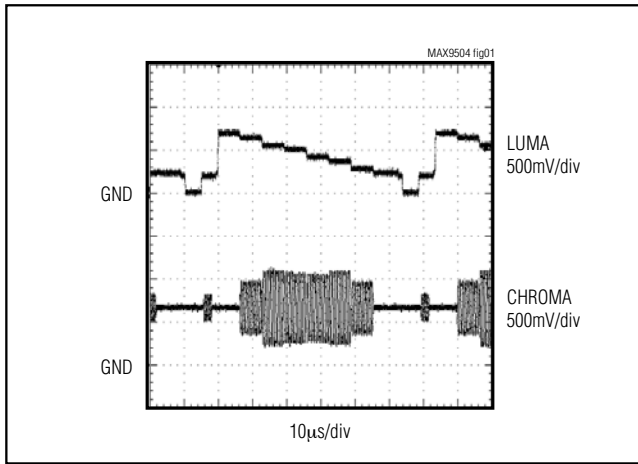

Figure 1. Oscilloscope Trace of Luma and Chroma Signals from Video Current DAC

Using the MAX9504A/MAX9504B with a Video Reconstruction Filter

In most video applications, the video signal generated from the DAC requires a reconstruction filter to smooth out the steps and reduce the spikes. The MAX9504 has a high-impedance, DC-coupled input that can be connected directly to the reconstruction filter.

For standard-definition video, the video passband is approximately 6MHz, and the DAC sampling clock is 27MHz. Normally, a 9MHz lowpass filter can be used for the reconstruction filter. This section demonstrates the methods to build simple 2nd- and 3rd-order passive Butterworth lowpass filters with 9MHz cutoff frequency. See Figures 2 and 3.

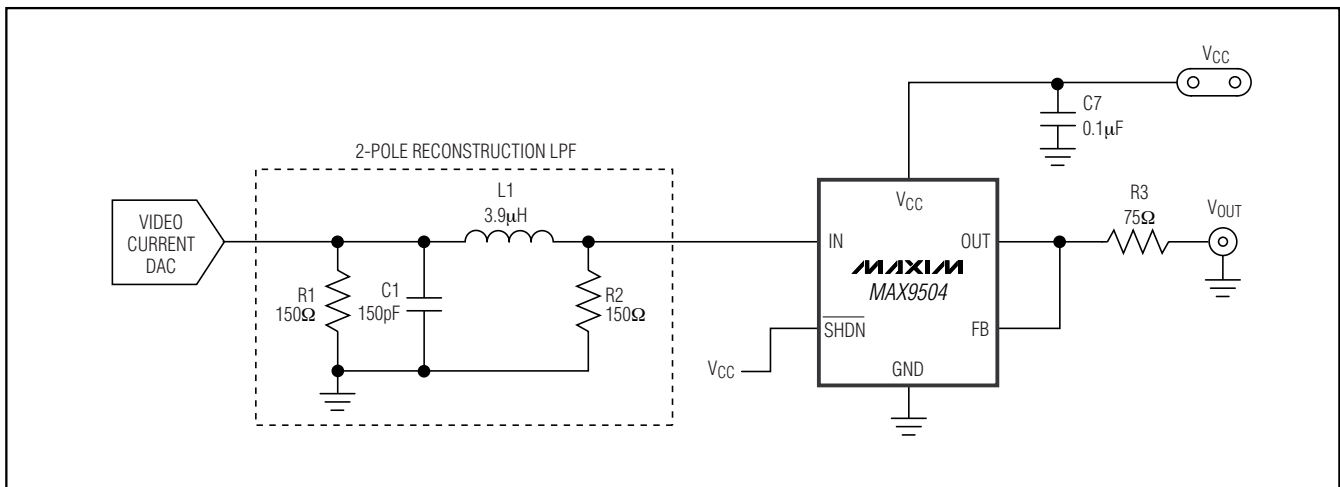

Figure 2. 2nd-Order Butterworth LPF with MAX9504

3V/5V, 6dB Video Amplifiers with High Output-Current Capability

MAX9504A/MAX9504B

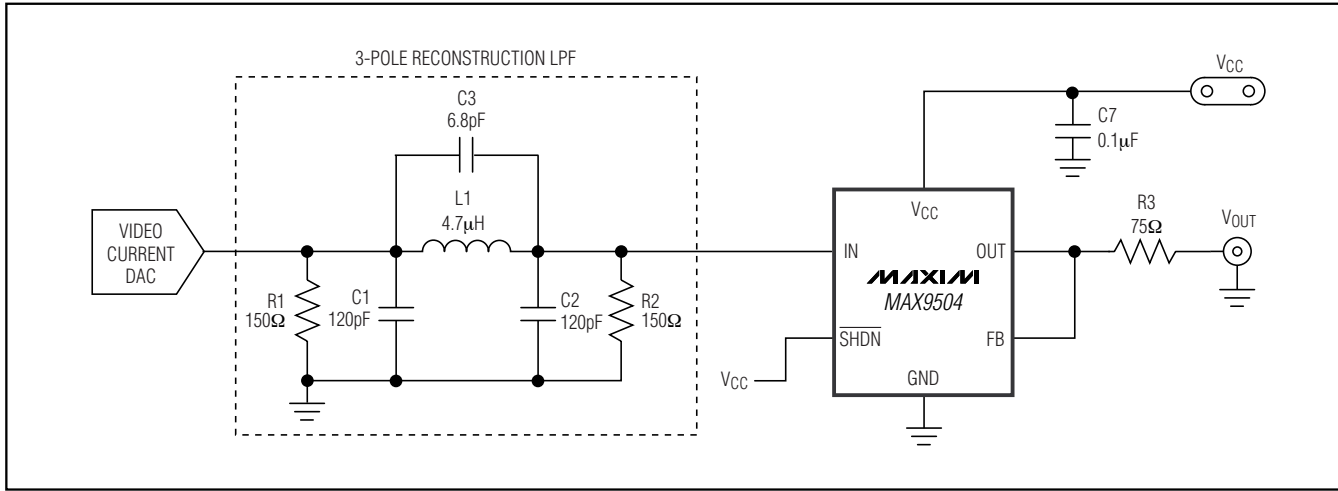

Figure 3. 3rd-Order Butterworth LPF with MAX9504

2nd-Order Butterworth Lowpass Filter Realization

Table 1 shows the normalized 2nd-order Butterworth LPF component values at 1 rad/s with a source/load impedance of 1Ω.

With the following equations, the L and C can be calculated for the cutoff frequency (f_c) at 9MHz. Table 2 shows the appropriate L and C values for different source/load impedances, the bench measurement values for the -3dB frequency and the attenuation at 27MHz. There is approximately 20dB attenuation at 27MHz, which decreases the spikes at the sampling frequency.

$$C1 = \frac{Cn1}{2\pi f_c R1}$$

$$L1 = \frac{Ln1 R1}{2\pi f_c}$$

Figure 4 shows the frequency response for $R1 = R2 = 150\Omega$. At 6MHz, the attenuation is about 1.4dB. The attenuation at 27MHz is about 20dB. Figure 5 shows the multiburst response for $R1 = R2 = 150\Omega$.

Table 1. 2nd-Order Butterworth Lowpass Filter Normalized Values

Rn1 = Rn2 (Ω)	Cn1 (F)	Ln1 (H)
1	1.414	1.414

Table 2. Bench Measurement Values (2nd-Order LPF)

R1 = R2 (Ω)	C1 (pF)	L1 (μH)	3dB FREQUENCY (MHz)	ATTENUATION AT 27MHz (dB)
75	330	1.8	8.7	20
150	150	3.9	9.0	20
200	120	4.7	9.3	22
300	82	8.2	8.7	20

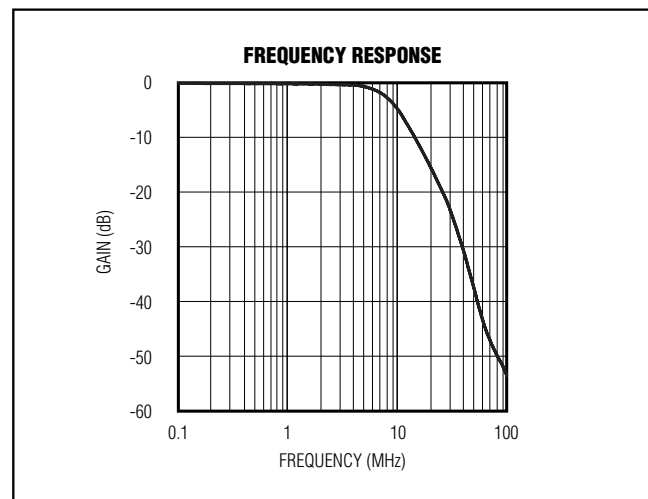

Figure 4. Frequency Response for 2nd-Order Lowpass Filter

3V/5V, 6dB Video Amplifiers with High Output-Current Capability

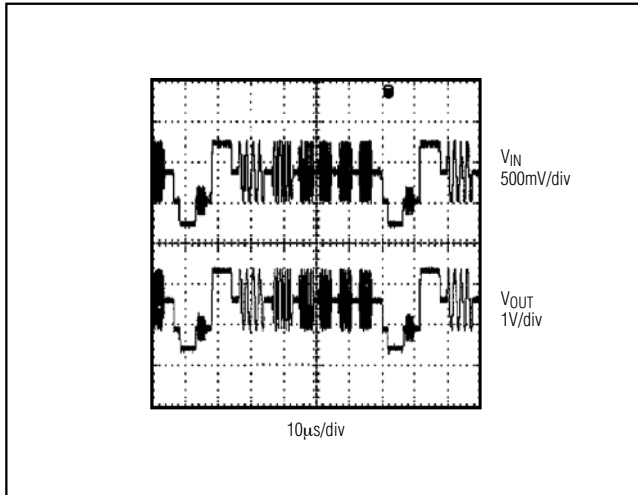

Figure 5. Multiburst Response

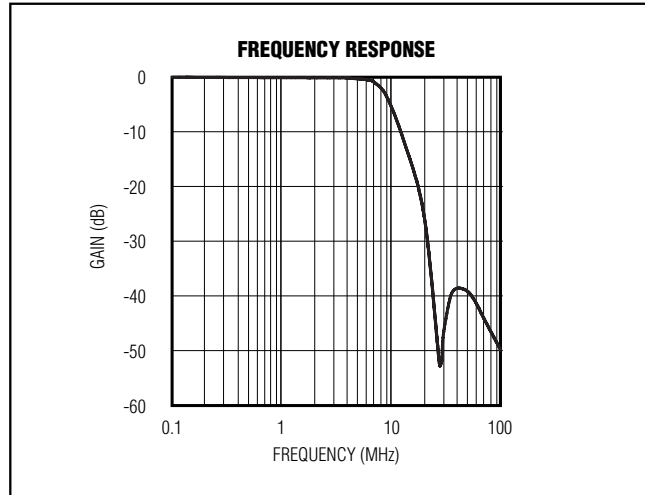

Figure 6. Frequency Response for 3rd-Order Lowpass Filter

3rd-Order Butterworth Lowpass Filter Realization

If a flatter passband and more stopband attenuation are desired, a 3rd-order lowpass filter can be used. The design procedures are similar to the 2nd-order Butterworth lowpass filter.

Table 3 shows the normalized 3rd-order Butterworth lowpass filter with the cutoff frequency at 1 rad/s and the stopband frequency at 3 rad/s. Table 4 shows the appropriate L and C values for different source/load impedances, the bench measurement values for the -3dB frequency and the attenuation at 27MHz. The attenuation is over 40dB at 27MHz. At 6MHz, the attenuation is approximately 0.6dB for $R_1 = R_2 = 150\Omega$ (Figure 6).

Table 3. 3rd-Order Butterworth Lowpass Filter Normalized Values

Rn1 = Rn2 (Ω)	Cn1 (F)	Cn2 (F)	Cn3 (F)	Ln1 (H)
1	0.923	0.923	0.06	1.846

Table 4. Bench Measurement Values—3rd Order LPF

R1 = R2 (Ω)	C1 (pF)	C2 (pF)	C3 (pF)	L (µH)	3dB FREQUENCY (MHz)	ATTENUATION AT 27MHz (dB)
75	220	220	15.0	2.2	9.3	43
150	120	120	6.8	4.7	8.9	50
300	56	56	3.3	10.0	9.0	45

Y/C-to-Composite Mixer and Driver Circuit

The Y/C-to-composite mixer and driver use two low-pass filters, the MAX9504A and the MAX9504B. In Figure 7, the top video DAC generates a luma signal, which is filtered through the passive RLC network and then amplified by the MAX9504B. The bottom video DAC generates a chroma signal, which is filtered and then amplified by the MAX9504A.

LUMA OUT is directly connected to the output of the MAX9504B through a 75Ω back-termination resistor; likewise, CHROMA OUT to the output of the MAX9504A. CVBS OUT (the composite video with blanking and sync output) is created by AC-coupling the chroma signal to the luma signal through the 470pF capacitor, which looks like an AC short at the color subcarrier frequency of 3.58MHz for NTSC or 4.43MHz for PAL.

This circuit relies upon the feature that the MAX9504A/MAX9504B can drive two loads at the same time.

3V/5V, 6dB Video Amplifiers with High Output-Current Capability

MAX9504A/MAX9504B

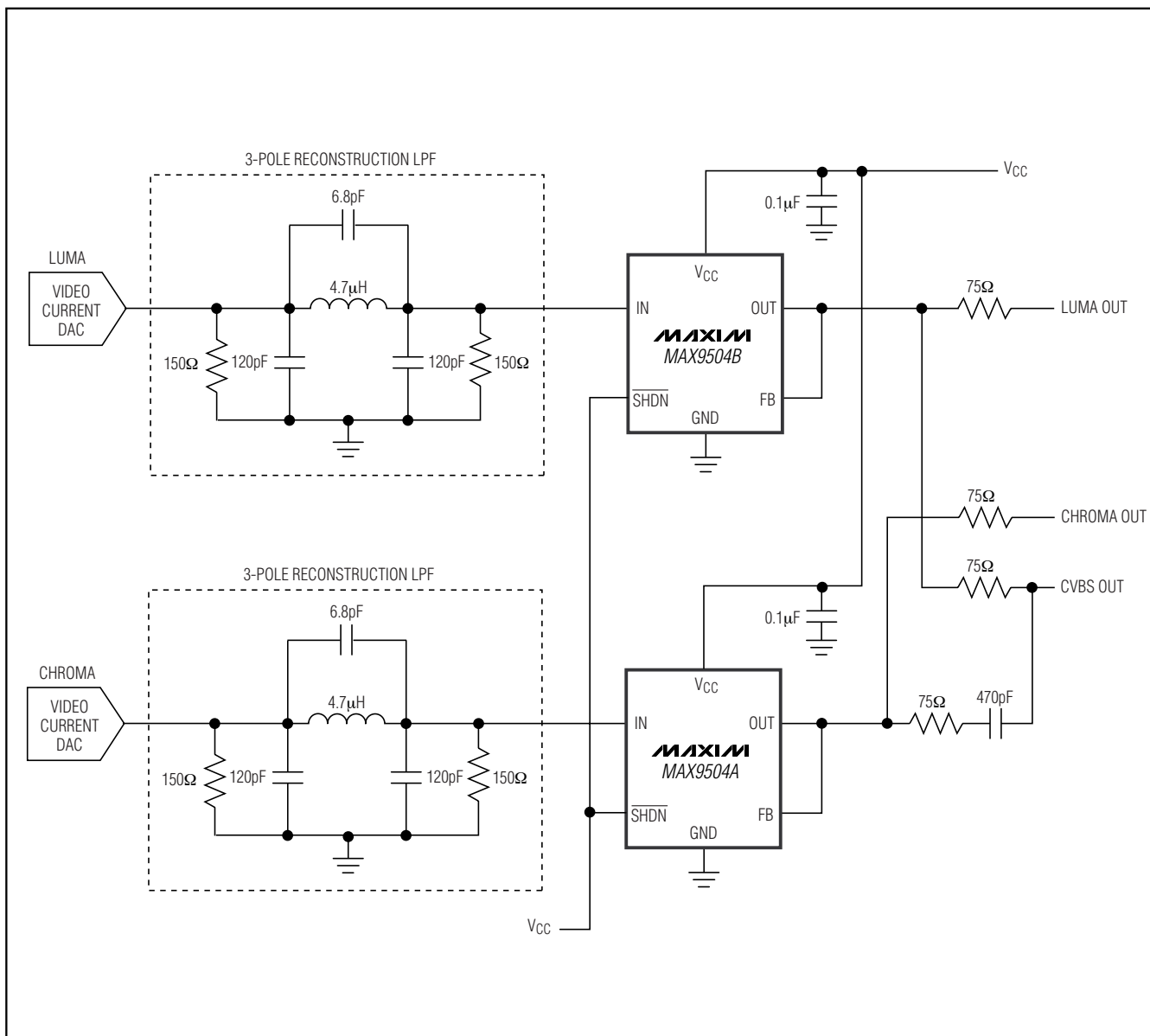

Figure 7. Y/C-to-Composite Mixer and Driver Circuit

3V/5V, 6dB Video Amplifiers with High Output-Current Capability

AC Output Coupling and Sag Correction

The MAX9504 can use the sag configuration if the output requires AC-coupling and $V_{CC} \geq 4.5V$. Sag correction refers to the low-frequency compensation for the highpass filter formed by the 150Ω load and the output capacitor. In video applications, the cutoff frequency must be less than 5Hz in order to pass the vertical sync interval and avoid field time distortion (field tilt). In the simplest configuration, a very large coupling capacitor ($> 220\mu F$ typically) is used to achieve the 5Hz cutoff frequency. In the sag configuration, two smaller capacitors are used to replace the very large coupling capacitor (see Figure 8). For $V_{CC} \geq 4.5V$, C5 and C6 are $22\mu F$ capacitors.

Layout and Power-Supply Bypassing

The MAX9504A/MAX9504B operate from a single 2.7V to 5.5V supply. Bypass the supply with a $0.1\mu F$ capacitor as close to V_{CC} possible. Maxim recommends using

microstrip and stripline techniques to obtain full bandwidth. To ensure that the PC board does not degrade the device's performance, design it for a frequency greater than 1GHz. Pay careful attention to inputs and outputs to avoid large parasitic capacitance. Whether or not you use a constant-impedance board, observe the following design guidelines:

- Do not use wire-wrap boards; they are too inductive.
- Do not use IC sockets; they increase parasitic capacitance and inductance.
- Use surface-mount instead of through-hole components for better, high-frequency performance.
- Use a PC board with at least two layers; it should be as free from voids as possible.
- Keep signal lines as short and as straight as possible. Do not make 90° turns; round all corners.

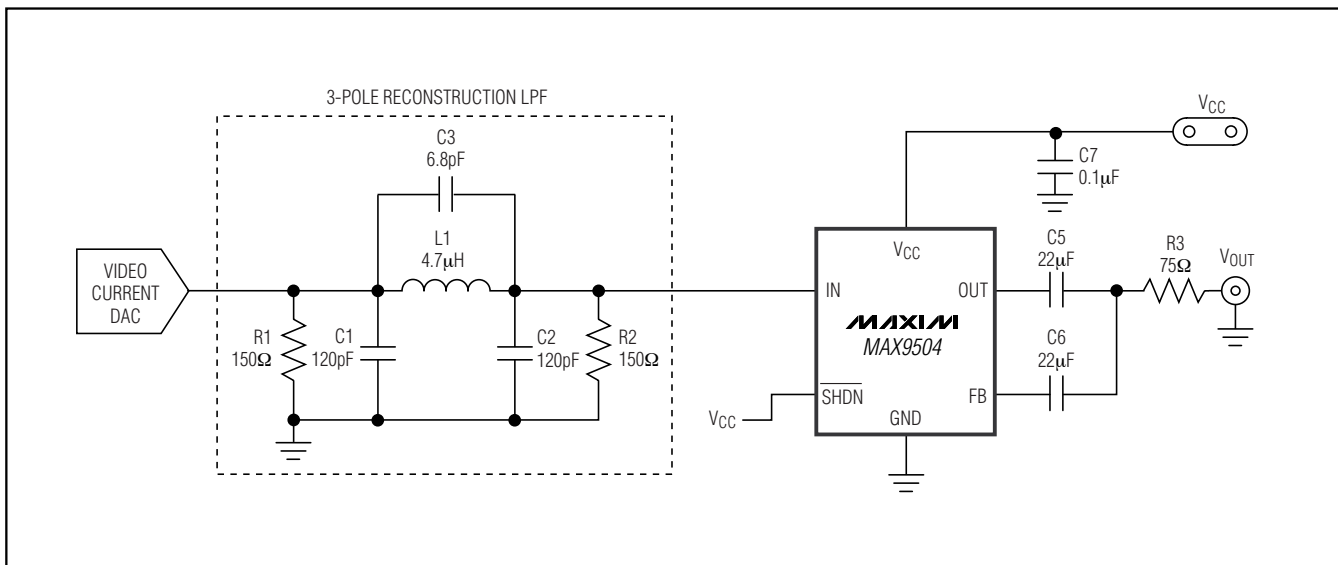
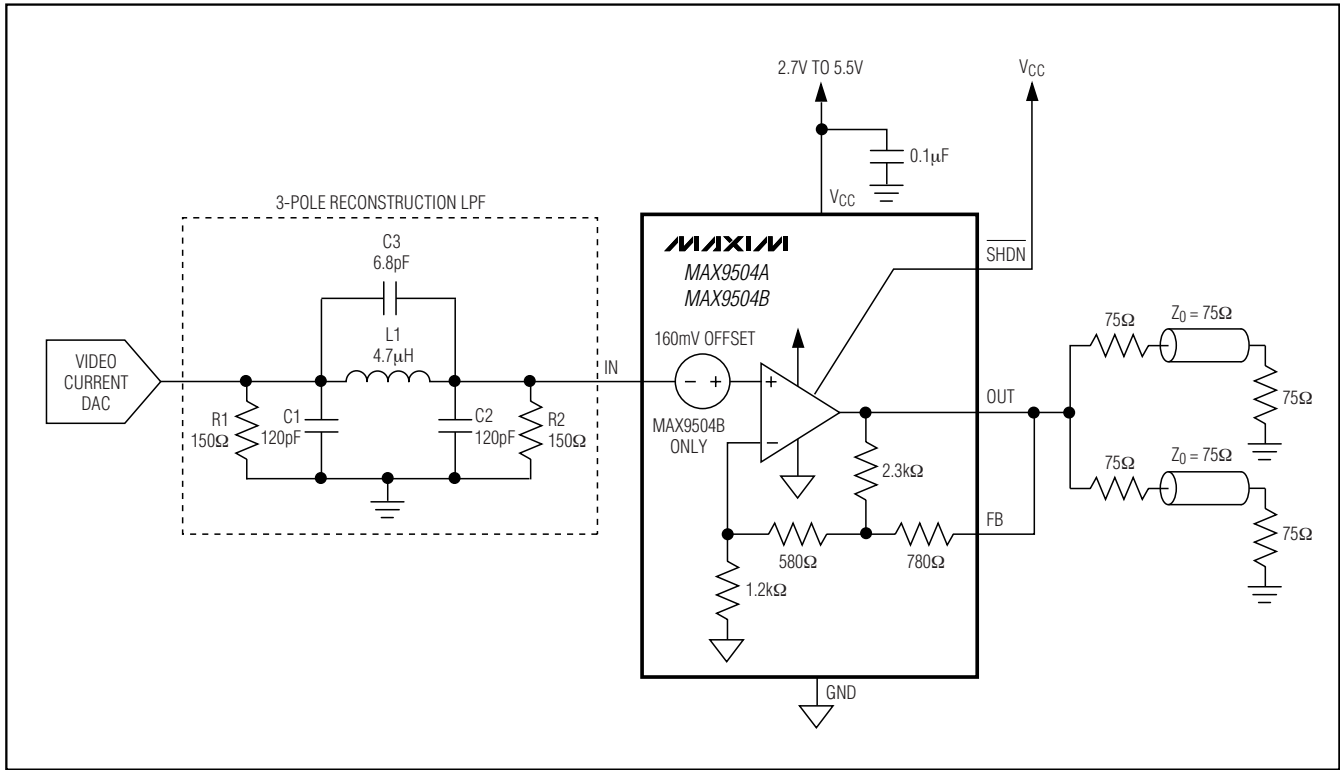

Figure 8. SAG Correction Configuration

3V/5V, 6dB Video Amplifiers with High Output-Current Capability

Typical Operating Circuit



MAX9504A/MAX9504B

Pin Configurations (continued)

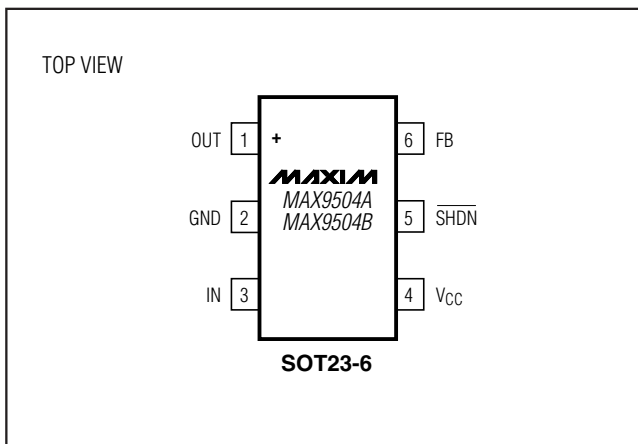

Chip Information

PROCESS: BiCMOS

3V/5V, 6dB Video Amplifiers with High Output-Current Capability

Package Information

(The package drawing(s) in this data sheet may not reflect the most current specifications. For the latest package outline information, go to www.maxim-ic.com/packages.)

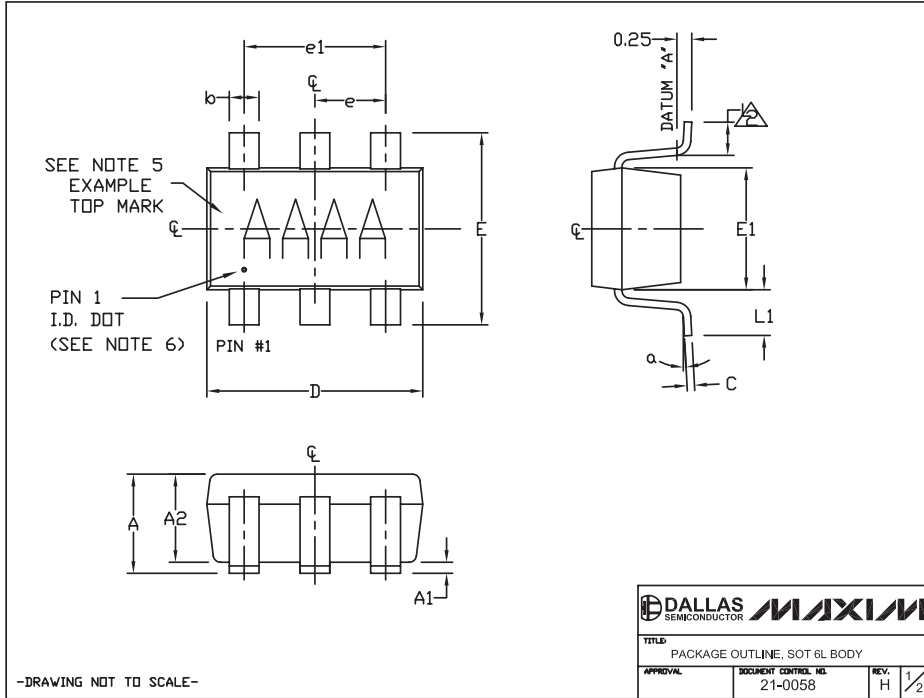

NOTES:

- ALL DIMENSIONS ARE IN MILLIMETERS.
- FOOT LENGTH MEASURED AT INTERCEPT POINT BETWEEN DATUM A & LEAD SURFACE.
- PACKAGE OUTLINE EXCLUSIVE OF MOLD FLASH & METAL BURR. MOLD FLASH, PROTRUSION OR METAL BURR SHOULD NOT EXCEED 0.25 MM.
- PACKAGE OUTLINE INCLUSIVE OF SOLDER PLATING.
- PIN 1 IS LOWER LEFT PIN WHEN READING TOP MARK FROM LEFT TO RIGHT. (SEE EXAMPLE TOP MARK)
- PIN 1 I.D. DOT IS 0.3 MM Ø MIN. LOCATED ABOVE PIN 1.
- MEETS JEDEC MO17B, VARIATION AB.
- SOLDER THICKNESS MEASURED AT FLAT SECTION OF LEAD BETWEEN 0.08mm AND 0.15mm FROM LEAD TIP.
- LEAD TO BE COPLANAR WITHIN 0.1 MM.

SYMBOL	MIN	NOMINAL	MAX
A	0.90	1.25	1.45
A1	0.00	0.05	0.15
A2	0.90	1.10	1.30
b	0.35	0.40	0.50
C	0.08	0.15	0.20
D	2.80	2.90	3.00
E	2.60	2.80	3.00
E1	1.50	1.625	1.75
L	0.35	0.45	0.60
L1		0.60 REF.	

3V/5V, 6dB Video Amplifiers with High Output-Current Capability

Package Information (continued)

(The package drawing(s) in this data sheet may not reflect the most current specifications. For the latest package outline information, go to www.maxim-ic.com/packages.)

MAX9504A/MAX9504B

6, 8, 10L UDFN.EPS

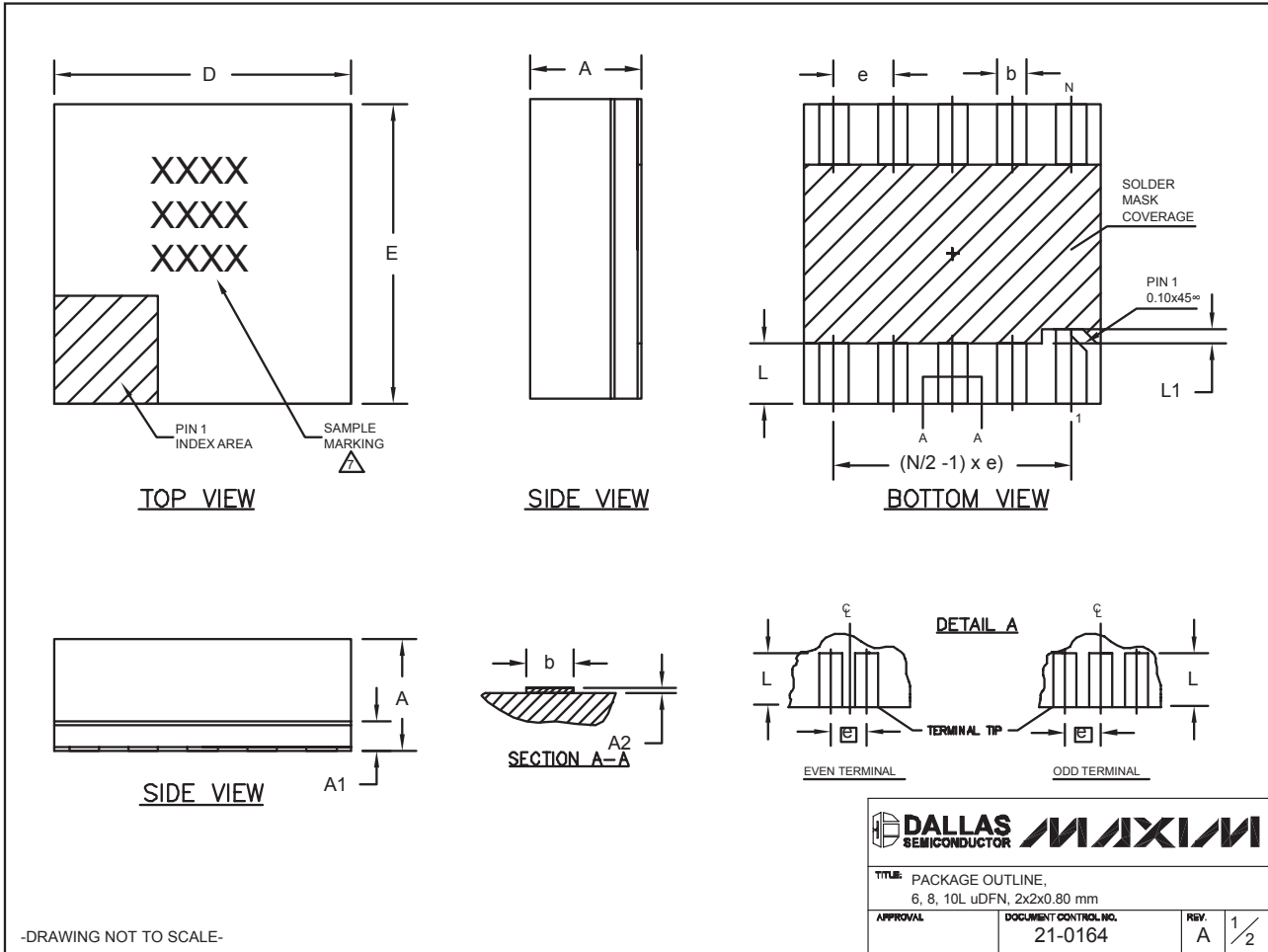

3V/5V, 6dB Video Amplifiers with High Output-Current Capability

Package Information (continued)

(The package drawing(s) in this data sheet may not reflect the most current specifications. For the latest package outline information, go to www.maxim-ic.com/packages.)

COMMON DIMENSIONS			
SYMBOL	MIN.	NOM.	MAX.
A	0.70	0.75	0.80
A1	0.15	0.20	0.25
A2	0.020	0.025	0.035
D	1.95	2.00	2.05
E	1.95	2.00	2.05
L	0.30	0.40	0.50
L1	0.10 REF.		

PACKAGE VARIATIONS				
PKG. CODE	N	e	b	(N/2 - 1) x e
L622-1	6	0.65 BSC	0.30±0.05	1.30 REF.
L822-1	8	0.50 BSC	0.25±0.05	1.50 REF.
L1022-1	10	0.40 BSC	0.20±0.03	1.60 REF.

NOTES:

1. ALL DIMENSIONS ARE IN mm. ANGLES IN DEGREES.
 2. COPLANARITY SHALL NOT EXCEED 0.08mm.
 3. WARPAGE SHALL NOT EXCEED 0.10mm.
 4. PACKAGE LENGTH/PACKAGE WIDTH ARE CONSIDERED AS SPECIAL CHARACTERISTIC(S).
 5. "N" IS THE TOTAL NUMBER OF LEADS.
 6. NUMBER OF LEADS SHOWN ARE FOR REFERENCE ONLY.
- ▲ MARKING IS FOR PACKAGE ORIENTATION REFERENCE ONLY.

-DRAWING NOT TO SCALE-

			
TITLE: PACKAGE OUTLINE, 6, 8, 10L uDFN, 2x2x0.80 mm			
APPROVAL	DOCUMENT CONTROL NO.	REV.	
	21-0164	A	2/2

Maxim cannot assume responsibility for use of any circuitry other than circuitry entirely embodied in a Maxim product. No circuit patent licenses are implied. Maxim reserves the right to change the circuitry and specifications without notice at any time.

16 _____ **Maxim Integrated Products, 120 San Gabriel Drive, Sunnyvale, CA 94086 408-737-7600**