

Features

- Meets and Exceeds the Requirements of ANSI TIA/EIA-644-1995
- Designed for clocking rates up to 320MHz
- Operates from a single 3.3V Supply
- Low Voltage Differential Signaling (LVDS) with Output Voltages of $\pm 350\text{mV}$ into a 100Ω load
- Choice between LVDS or TTL clock input
- Synchronous Enable/Disable
- Clock outputs default LOW when inputs open
- Multiplexed clock input
 - Internal $300\text{k}\Omega$ pullup resistor on input pins
 - CLK and $\overline{\text{CLK}}$ have 110Ω internal termination (PI90LVT14)
- 50ps Output-to-Output Skew
- 475ps typical propagation delay
- Bus Pins are high impedance when disabled or with V_{CC} less than 1.5V
- TTL inputs are 5V Tolerant
- Power Dissipation at 400Mbps/s of 150mW
- Function compatible to Motorola (PECL) MC100EL14 and Micrel/Synergy (PECL) SY100EL14V
- >9kV ESD Protection
- 20-pin TSSOP (L) and QSOP (Q) packages

Pin Descriptions

Pin	Function
CLK, $\overline{\text{CLK}}$	Differential Clock Outputs
SCLK	LVTTTL Clock Input
$\overline{\text{EN}}$	Synchronous Enable
SEL	Clock Select Input
CLK1-5 $\text{OUT}\pm$	Differential Clock Inputs

Function Table

CLK	SCLK	SEL	$\overline{\text{EN}}^*$	CLKOUT+
L	X	L	L	L
H	X	L	L	H
X	L	H	L	L
X	H	H	L	H
\downarrow	\downarrow	X	H	Z*

* On next negative transition of CLK, or SCLK

Description

The PI90LV14 implements low voltage differential signaling (LVDS) to achieve clocking rates as high as 320MHz with low skew.

The PI90LV14 is a low-skew 1:5 clock distribution chip which incorporates multiplexed clock inputs to allow for distribution of a lower-speed, single-ended clock or a high-speed system clock. When LOW the SEL pin will select the differential clock input.

The common enable ($\overline{\text{EN}}$) is synchronous so that the outputs will only be enabled/disabled when they are already in the LOW state. This avoids any chance of generating a runt clock pulse when the device is enabled/disabled as can happen with an asynchronous control. Because the internal flip-flop is clocked on the falling edge of the input clock, all associated specification limits are referenced to the negative edge of the clock input.

The intended application of these devices and signaling technique is for high-speed clock distribution between boards.

PI90LV14 Block Diagram

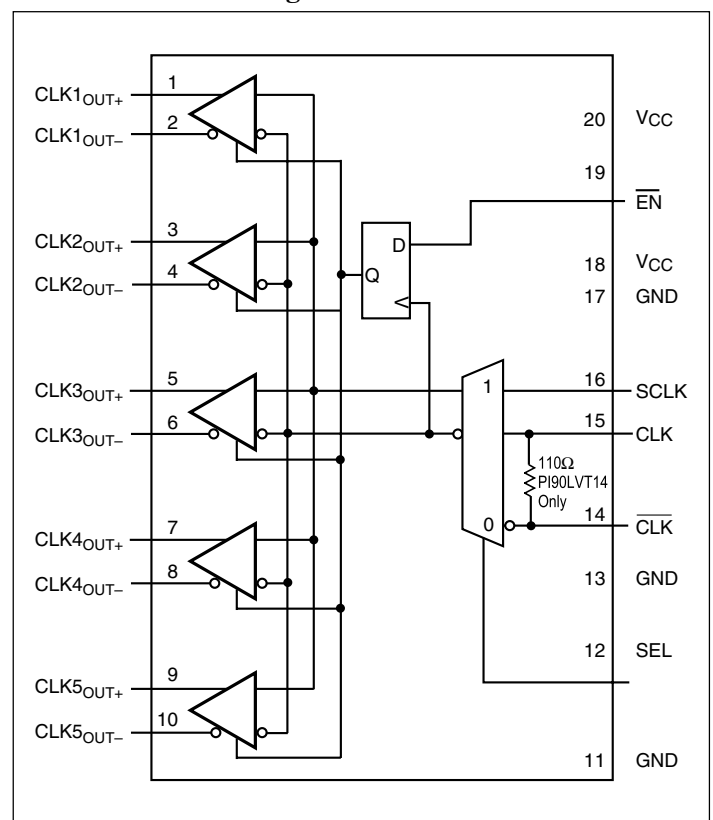

Electrical Characteristics over Recommended Operating Conditions (unless otherwise noted).

Symbol	Parameter	Test Conditions	Min.	Typ. ⁽¹⁾	Max.	Units
$ V_{OD} $	Differential output voltage magnitude	$R_L = 100\Omega$ See Figures 1 and 2	247	340	454	mV
$\Delta V_{OD} $	Change in differential output voltage magnitude between logic states		-50		50	
$V_{OC(SS)}$	Steady-state common-mode output voltage	See Figure 3	1.125	1.40	1.7	V
$\Delta V_{OC(SS)}$	Change in steady-state common-mode output voltage between logic states		-50		50	
$V_{OC(PP)}$	Peak-to-peak common-mode output voltage			60	100	
I_{CC}	Supply Current	Enabled, $R_L = 100\Omega$ $V_{IN} = V_{CC}$ or GND		21	35	mA
		Disabled, $V_{IN} = V_{CC}$ or GND	0.5	2.5	4.0	
I_{IH}	High-level input current	$V_{IH} = 2V$		3.0	20	μA
I_{IL}	Low-level input current	$V_{IL} = 0.8V$		5.0	20	
I_{OS}	Short-circuit output current	V_{ODOUT+} or $V_{ODOUT-} = 0V$			± 7.4	mA
		$V_{OD} = 0V$			± 4.7	
I_{OZ}	High-impedance output current	$V_O = 0V$ or V_{CC}			1	μA
$I_{O(OFF)}$	Power-off output current	$V_{CC} = 1.5V$, $V_O = 2.4V$			1	
C_{IN}	Input capacitance,	$V_I = 0.4 \sin(4E6\pi t) + 0.5V$		9		pF
C_O	Output capacitance	$V_I = 0.4 \sin(4E6\pi t) + 0.5V$, Disabled		10		
R_{TERM}	Termination Resistor	PI90LVT14	90	110	132	Ω

Switching Characteristics over Recommended Operating Conditions (unless otherwise noted)^(8,9).

Characteristic	Symbol	Min.	Typ.	Max.	Units	Condition
Propagation Delay to Output CLK to CLKOUT ± SCLK to CLKOUT ± SEL to CLKOUT ±	t _{PLH} t _{PHL}		3.0 2.5 2.6	4.0 3.5 3.6	ns	
Disable Time CLK or SCLK to CLKOUT ±	t _{PHZ} t _{PLZ} t _{PZH} t _{PZL}		2.7 2.7 4.7 3.7	3.5 3.5 6.0 6.0	ns	2
Part-to-Part Skew CLK (Diff) to Q CLK (SE), SCLK to Q With Device Skew	t _{skew} t _{skew} t _{skew}			TBD TBD TBD		1
Setup Time EN _x to CLK CEN to CLK	t _s t _s	100 100	-100 -100		ps	2
Hold Time EN _x , CEN to SCLK EN _x , CEN to CLK _x	t _h t _h		550 500	720 720		2
Minimum Input Swing (CLK)	V _{PP}	0.20		0.800	V	3
Com. Mode Range (CLK)	V _{CMR}	0.125	1.5	V _{CC} - 0.20		4
Rise/Fall Times (20 – 80%) SCLK to CLKOUT± SCLK to CLKOUT±	t _r t _f	150 150		1200 1200	ps	
Duty Cycle Distortion Pulse Skew (t_{PLH} - t_{PHL})	t _{SK1R}		200	300		5
Channel-to-Channel Skew, same edge	t _{SK2R}		70	190		6
Maximum Operating Frequency			250		MHz	7

Notes:

1. Within-Device skew is defined for identical transitions on similar paths through a device.
2. Setup, Hold, and Disable times are all relative to a falling edge on CLK or SCLK.
3. Minimum input swing for which AC parameters are guaranteed. Full DC LVDS output swings will be generated with only 50mV input swings.
4. The range in which the high level of the input swing must fall while meeting the V_{PP} spec.
5. t_{SK1R} is the difference in receiver propagation delay (t_{PLH}-t_{PHL}) of one device, and is the duty cycle distortion of the output at any given temperature and V_{CC}. The propagation delay specification is a device-to-device worst case over process, voltage, and temperature.
6. t_{SK2R} is the difference in receiver propagation delay between channels in the same device of any outputs switching in the same direction. This parameter is guaranteed by design and characterization.
7. Generator input conditions: t_rt_f < 1ns, 50% duty cycle, differential (1.10V to 1.35V peak-peak).
Output Criteria: 60%/40% duty cycle, V_{OL}(max) 0-4V, V_{OH}(min) 2.7V, Load - 7pF (stray plus probes).
8. C_L includes probe and fixture capacitance.
9. Generator waveform for all tests unless otherwise specified: f = 25 MHz, Z₀ = 50Ω, t_r = 1ns, t_f = 1ns (35%-65%). To ensure fastest propagation delay and minimum skew, clock input edge rates should not be slower than 1ns/V; control signals not slower than 3ns/V.

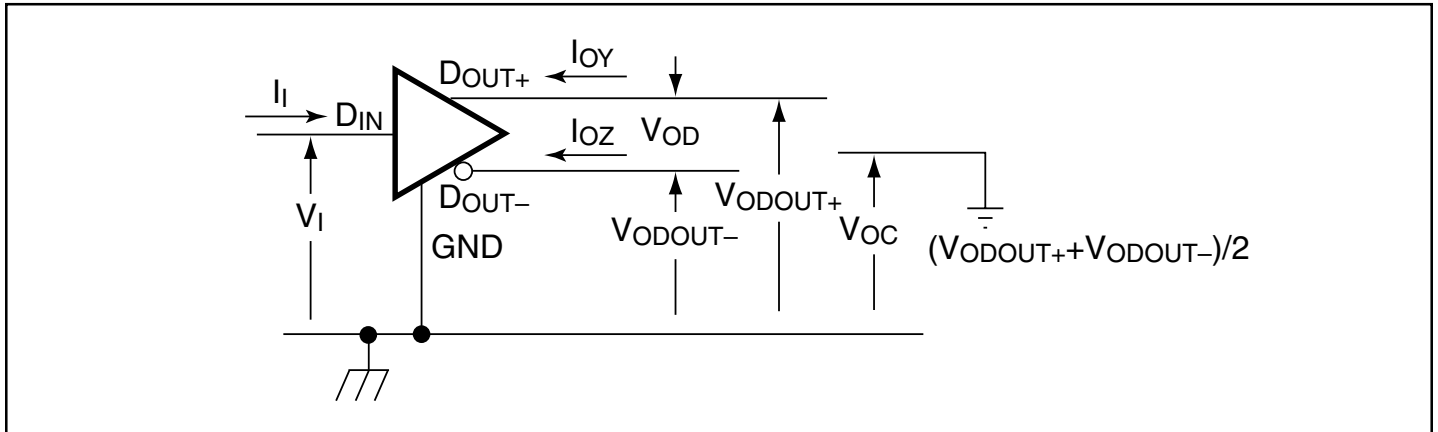
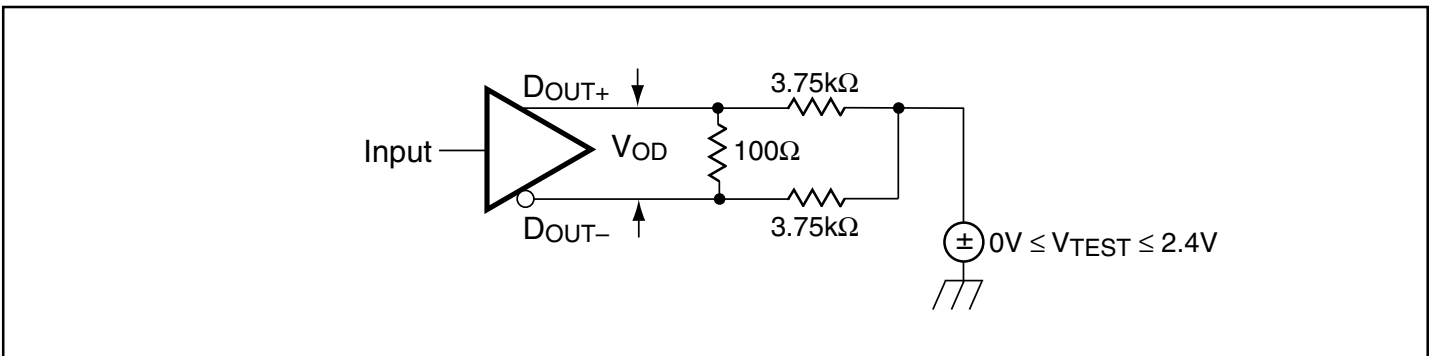
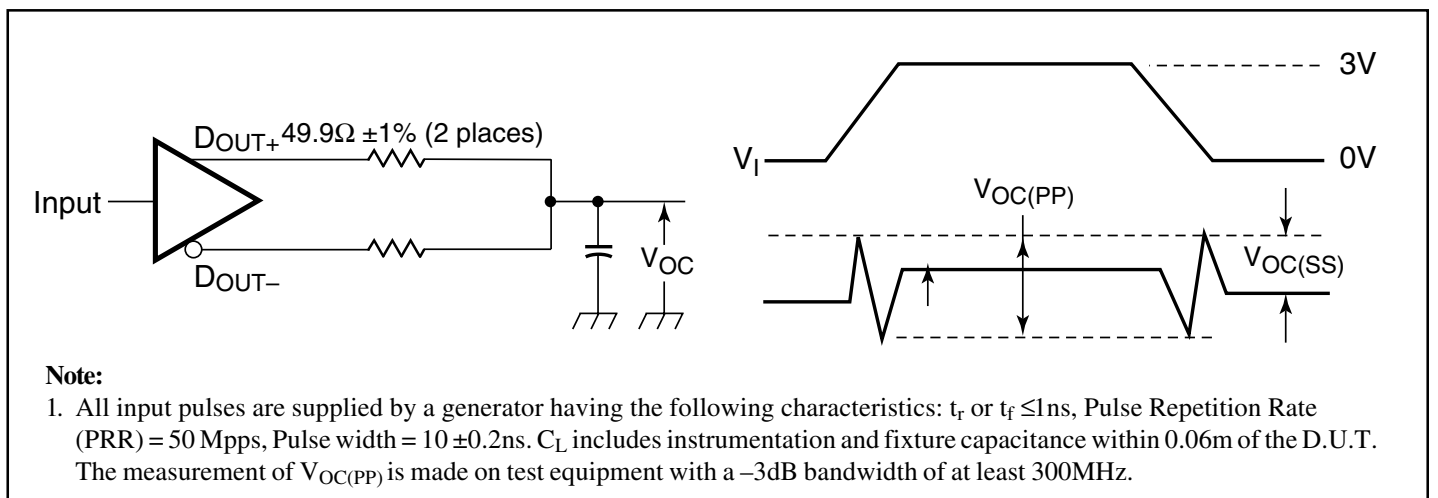
Parameter Measurement Information

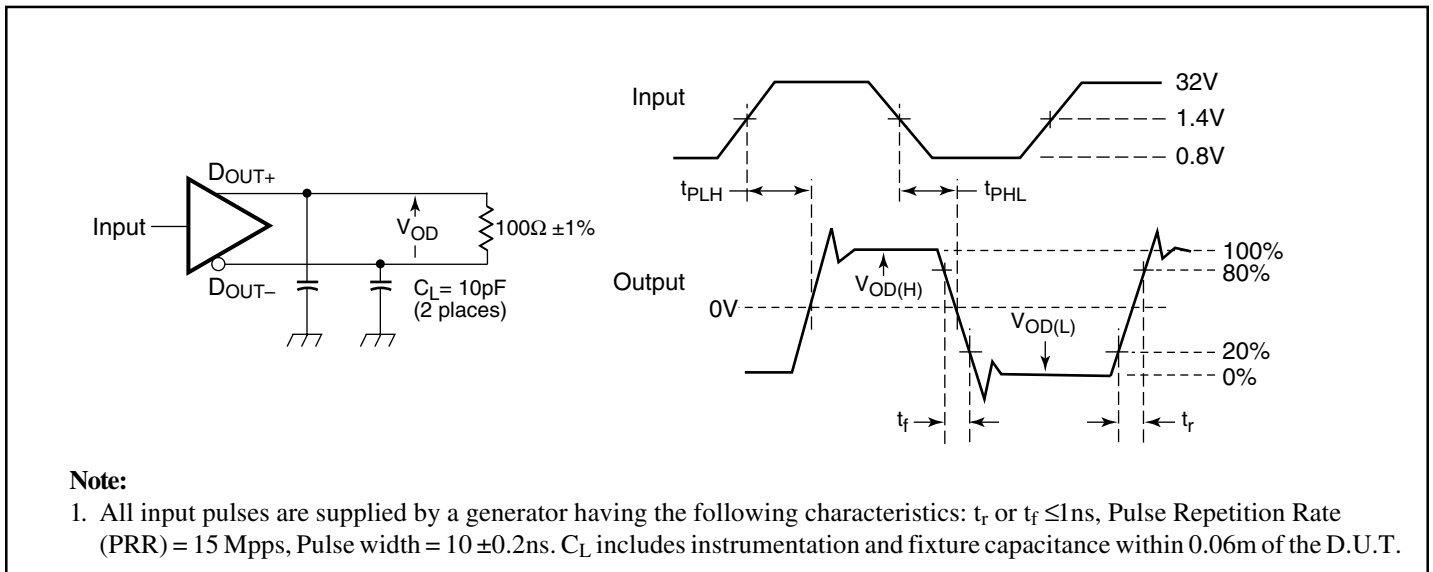
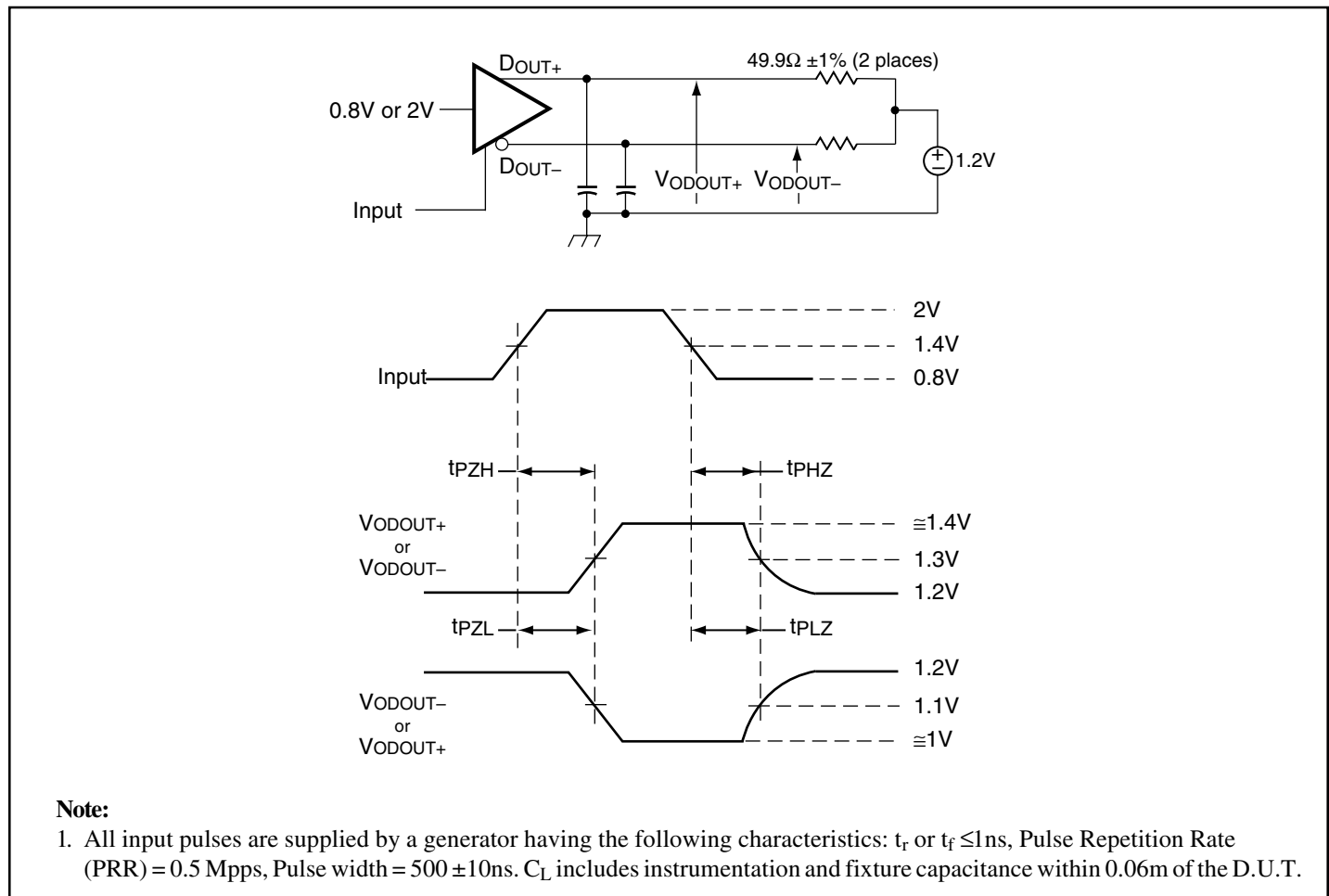
Figure 1. Voltage and Current Definitions

Figure 2. V_{OD} Test Circuit

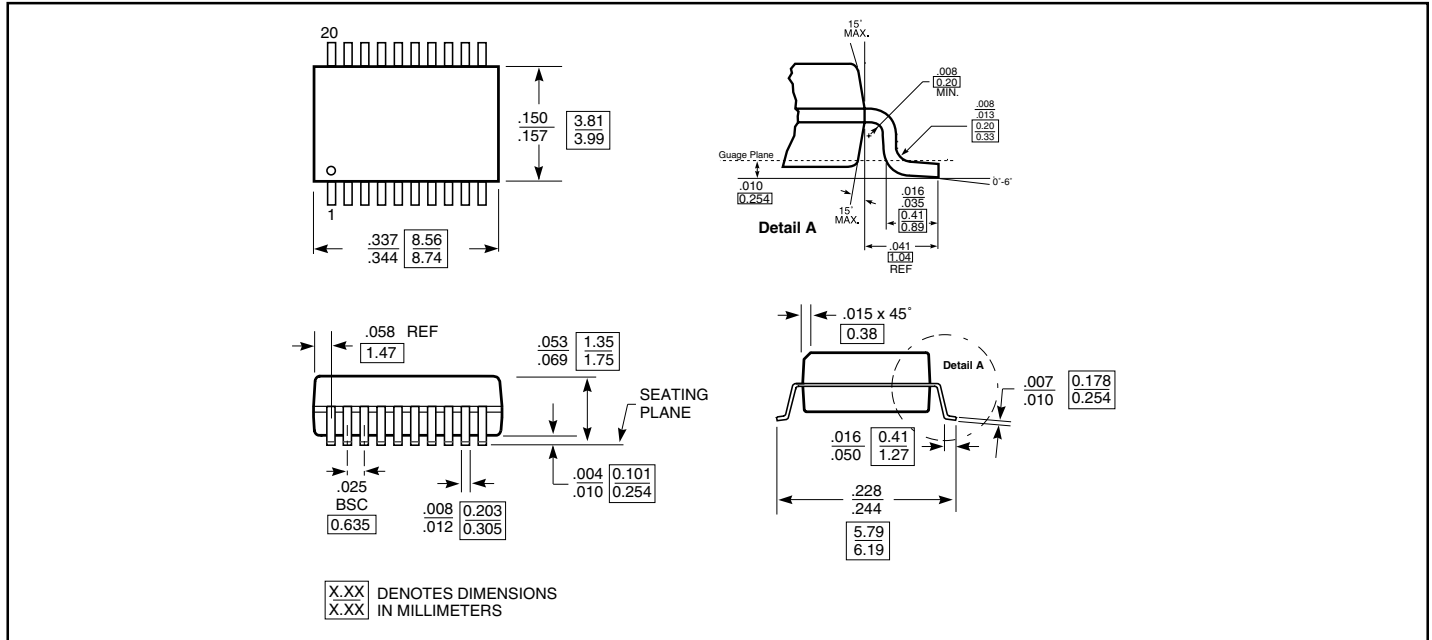
Figure 3. Test Circuit & Definitions for the Driver Common-Mode Output Voltage

Parameter Measurement Information (continued)

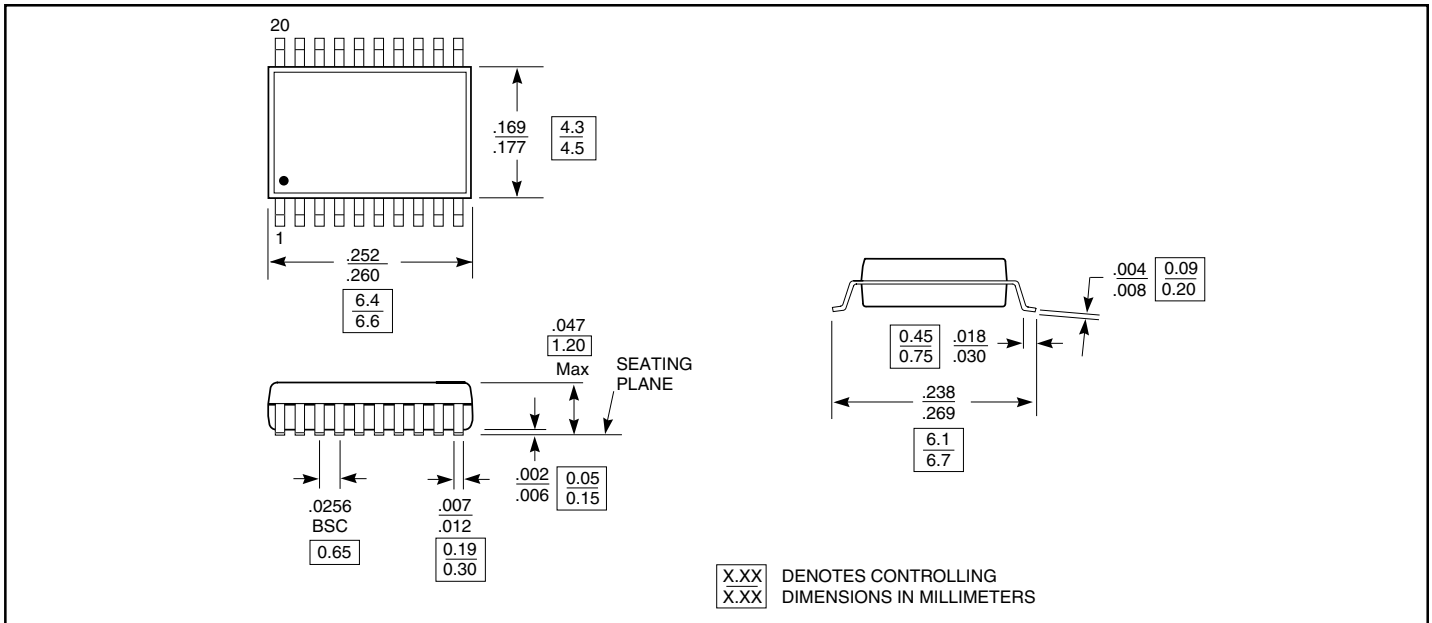
Figure 4. Test Circuit, Timing, & Voltage Definitions for the Differential Output Signal

Figure 5. Enable & Disable Time Circuit & Definitions

20-Pin QSOP (Q) Package



20-Pin TSSOP (L) Package



Ordering Information

Ordering Code	Package Type	Ordering Range
PI90LV14L	20-Pin 173-mil TSSOP	-40°C to 85°C
PI90LVT14L		
PI90LV14Q	20-Pin 150-mil QSOP	
PI90LVT14Q		

Pericom Semiconductor Corporation

2380 Bering Drive • San Jose, CA 95131 • 1-800-435-2336 • Fax (408) 435-1100 • <http://www.pericom.com>