



SANYO Semiconductors

DATA SHEET

An ON Semiconductor Company

LV8162TT — Bi-CMOS IC Fan Motor Driver Single-Phase Full-Wave Driver

Overview

The LV8162TT is a driver IC for single-phase fan motors that achieves low-noise operation by using BTL linear output system. As it has a variable speed function in response to the external PWM input signal, it is best suited for driving CPU cooling fans in notebook PCs and other applications that require low power consumption, low noise, and a variable speed function.

Functions

- Single-phase full-wave operating by BTL output
- Hall bias output pin
- Standby mode and quick start function
- FG (rotation speed detection) signal pin and RD (lock detection) signal pin
- Built-in thermal-shutdown (TSD) circuit
- Speed control available by PWM pin
- Built-in lock protection and automatic return circuit
- Start auxiliary function (50% duty start)

Specifications

Absolute Maximum Ratings at Ta = 25°C

Parameter	Symbol	Conditions	Ratings	Unit
Maximum supply voltage	V _{CC} max		7	V
Maximum output current	I _{OUT} max		0.7	A
OUT pin output withstand voltage	V _{OUT} max		7	V
HB pin maximum output current	I _{HB} max		10	mA
PWM pin withstand voltage	V _{PWM} max		7	V
FG/RD pin maximum sink current	I _{FG/RD} max		5	mA
FG/RD pin output withstand voltage	V _{FG/VRD} max		7	V
Allowable dissipation	Pd max1	Independent IC	200	mW
	Pd max2	With specified substrate *1	400	mW
Operating temperature	T _{opr}	*2	-30 to +95	°C
Storage temperature	T _{stg}		-55 to +150	°C

Continued on next page.

■ Any and all SANYO Semiconductor Co.,Ltd. products described or contained herein are, with regard to "standard application", intended for the use as general electronics equipment. The products mentioned herein shall not be intended for use for any "special application" (medical equipment whose purpose is to sustain life, aerospace instrument, nuclear control device, burning appliances, transportation machine, traffic signal system, safety equipment etc.) that shall require extremely high level of reliability and can directly threaten human lives in case of failure or malfunction of the product or may cause harm to human bodies, nor shall they grant any guarantee thereof. If you should intend to use our products for new introduction or other application different from current conditions on the usage of automotive device, communication device, office equipment, industrial equipment etc. , please consult with us about usage condition (temperature, operation time etc.) prior to the intended use. If there is no consultation or inquiry before the intended use, our customer shall be solely responsible for the use.

■ Specifications of any and all SANYO Semiconductor Co.,Ltd. products described or contained herein stipulate the performance, characteristics, and functions of the described products in the independent state, and are not guarantees of the performance, characteristics, and functions of the described products as mounted in the customer's products or equipment. To verify symptoms and states that cannot be evaluated in an independent device, the customer should always evaluate and test devices mounted in the customer's products or equipment.

LV8162TT

Continued from preceding page.

* 1: Specified substrate : 20mm × 10mm × 0.8mm, Paper phenol

* 2: Tj max=150°C must not be exceeded

Caution 1) Absolute maximum ratings represent the value which cannot be exceeded for any length of time.

Caution 2) Even when the device is used within the range of absolute maximum ratings, as a result of continuous usage under high temperature, high current, high voltage, or drastic temperature change, the reliability of the IC may be degraded. Please contact us for the further details.

Recommended Operating Conditions at Ta = 25°C

Parameter	Symbol	Conditions	Ratings	Unit
Recommended supply voltage	V _{CC}		5.0	V
Operating supply voltage range	V _{CC op}		2.0 to 6.0	V
Hall input voltage range	V _{ICM}		0.2 to V _{CC} -1.2	V
PWM input frequency	f _{PWM IN}		20 to 60	kHz

Electrical Characteristics at Ta = 25°C, V_{CC} = 5V

Parameter	Symbol	Conditions	Ratings			Unit
			min	typ	max	
Circuit current	I _{CC}		0.95	1.3	1.6	mA
	I _{CC st}			10	30	μA
HB pin voltage	V _{HB}	When I _{REG} = 5mA	0.9	1.03	1.2	V
OUT pin high voltage	V _{OH}			0.16	0.23	V
OUT pin low voltage	V _{OL}	I _O = 250mA, source + sink		0.1	0.15	V
Hall amplifier input offset voltage	V _{IN OFS}		-6		6	mV
Hall amplifier voltage gain	GH		44	45.5	47	dB
PWM pin input low level	V _{PWML}	V _{SET} = 0.5V	0		V _{CC} ×0.2	V
PWM pin input high level	V _{PWMH}	V _{SET} = 0.5V	V _{CC} ×0.8		6	V
FG/RD pin low voltage	V _{FG L} /V _{RD L}	ICPRTO = ICPC/ICPD			0.3	V
FG/RD pin leakage current	I _{FG L} /I _{RD L}				10	μA
FG comparator hysteresis width	FGHYS	V _{SET} = 0.5V		±8	±16	sec
Lock detection output ON time	LT1		0.4	0.6	0.8	μsec
Lock detection output OFF time	LT2	I _{FG} = 3mA	4	6	8	V
Lock detection output ON/OFF ratio	LRTO	V _{FG} = 5V	8	10	12	
Thermal shutdown operating temperature	TSD	Design guarantee *		180		°C
Thermal shutdown hysteresis width	ΔTSD	Design guarantee *		30		°C

* Design guaranteed value (No measurement is performed.)

Package Dimensions

unit : mm (typ)

3375

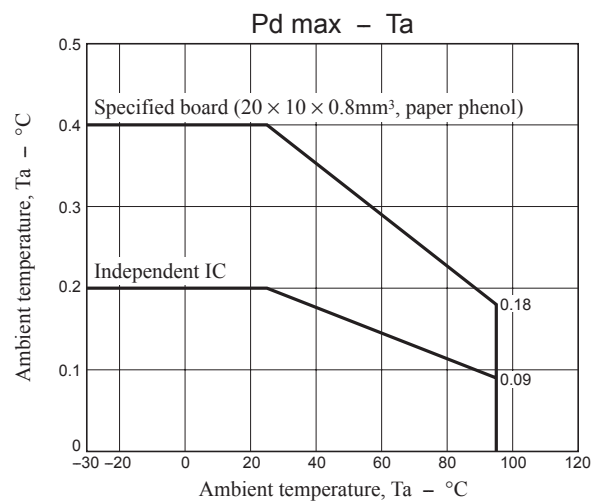
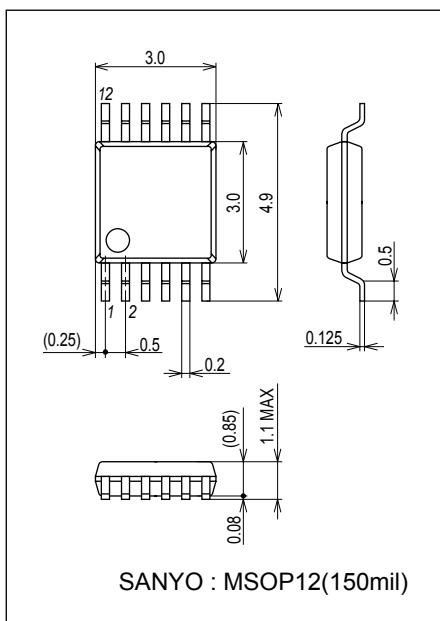

LV8162TT

Pin Assignment

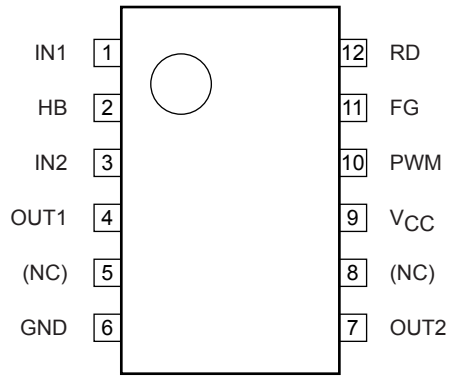

Top view

Truth value table

IN1	IN2	PWM	OUT1	OUT2	FG	RD	Mode
H	L	H	L	H	OFF	L	Drive (OUT2 → OUT1)
		L		L		Regeneration	
		*		OFF		Lock protection. See *1	
L	H	H	H	L	L	L	Drive (OUT1 → OUT2)
		L	L			Regeneration	
		*	OFF			Lock protection. See *1	
*		L	L	L	OFF	L	Standby mode. See *2

*1: If no FG pulse switching occurs while the lock detection output is on, the IC enters lock protection mode.

*2: If "lock protection operation + PWM input low time" is 750μs or longer is satisfied, the IC enters standby mode.

The IC enters standby mode at a low time of 750μs only when the IC is started with low PWM input when the power is turned on.

Block Diagram

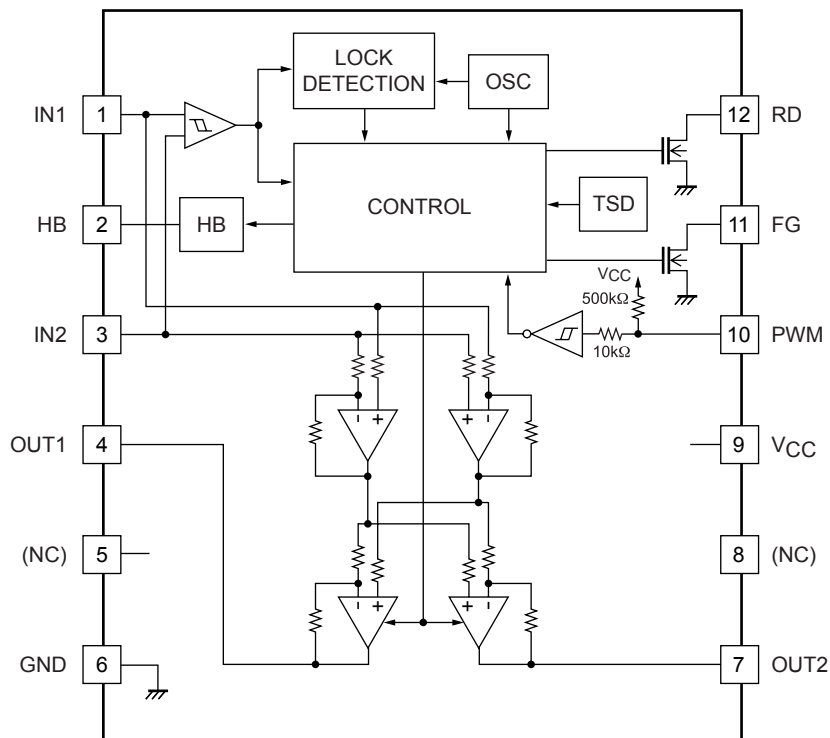

Application Circuit Example

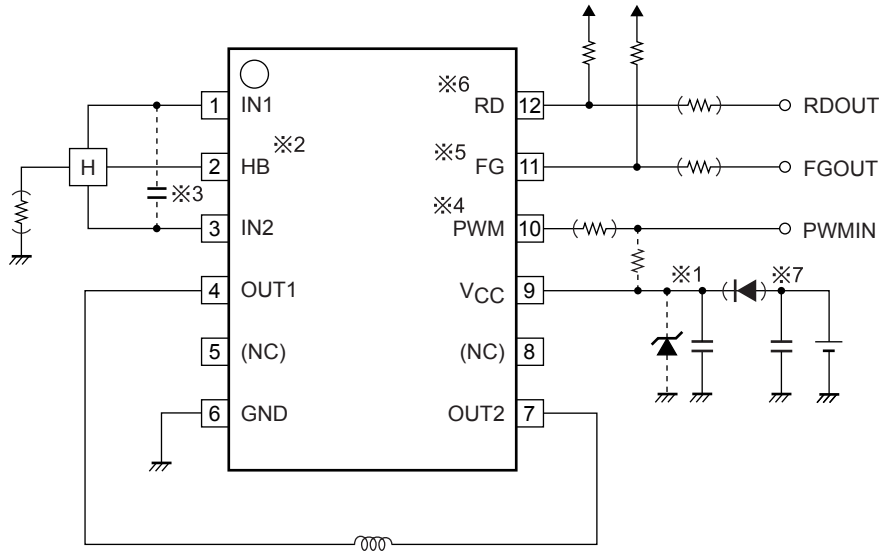

*1 [Power stabilization capacitor]

Be sure to use the power stabilization capacitor with a capacitance of 1μF or higher. It cannot be removed.

The VCC and GND are connected using a pattern that is thick and short as possible.

When a reverse-connection breakdown prevention diode is used and the supply voltage rises due to a coil kickback or other cause, increase the capacitance of the capacitor or use a zener diode between the power supply and GND to ensure that the absolute maximum rating is not exceeded.

This IC performs synchronous rectification for reducing heat generation and improving efficiency. The synchronous rectification can return the current to the power supply side under certain operating conditions.

- When the output duty drops suddenly
- When the PWM input frequency is low

The amount of increase in the supply voltage varies depending on whether a reverse-connection breakdown prevention diode is used, on the size of the power supply capacitor, and fan type, and so these factors must be fully taken into consideration.

When the supply voltage rises, in the same way as above, increase the capacitance of the capacitor or use a zener diode between the power supply and GND to ensure that the absolute maximum rating is not exceeded.

*2 [HB pin]

Constant-voltage output pin. This is used for Hall element bias purposes.

If the HB pin is not needed because the bias current to the Hall element is supplied from the power supply, pull this pin down to GND with a resistor of about 1kΩ.

The power supply bias and HB pin bias cannot be used at the same time.

To adjust the amplitude of the Hall element, insert a resistor between the Hall element and GND.

*3 [IN1 and IN2 pins]

Hall element signal input pin.

The wiring must be made as short as possible to prevent carrying of noise.

If noise is carried, insert a capacitor between IN1 and IN2 pins.

The Hall input level must satisfy the following condition:

Difference voltage between IN1 and IN2 > Operating voltage / Hall amplifier gain + Hall amplifier input offset.

*4 [PWM pin]

Speed control signal input pin.

The PWM pin is pulled up with a 500k Ω resistor inside the IC.

The 500k Ω is used for setting full speed when the PWM pin is open, and if speed control is to be performed by open collector (open drain) input, it is necessary to pull up the pin using a resistor of an appropriate value.

If speed control is performed using a push-pull input, a pull-up resistor is not required.

When the speed control is performed using the open collector input above, or when push-pull input is used and no pull-up resistor is used, the IC can be used without a sequence (power supply and PWM input can be turned on in any order).

It is recommended that a resistor of 1k Ω or more is connected in series to protect the pin against misconnection such as ground open and reverse connection.

*5 [FG pin]

Rotational speed detection pin.

This is open drain output that can detect the rotational speed by the FG output in response to the phase switching signal.

This pin is held off when in standby mode.

Keep this pin open when it is not to be used.

It is recommended that a resistor of 1k Ω or more is connected in series to protect the pin against misconnection such as ground open and reverse connection.

*6 [RD pin]

Lock detection pin.

This is open drain output that is low during rotation, off when lockup is detected, and low when in standby mode.

Keep this pin open when it is not to be used.

It is recommended that a resistor of 1k Ω or more is connected in series to protect the pin against misconnection such as ground open and reverse connection.

*7 [Low current consumption during standby]

The fan motor controlled using this IC can be set to a current consumption of 10 μ A (room temperature, typ.) when in standby mode. However, note that it will not become 10 μ A under any of the following conditions.

- When the Hall element bias current is fed from the power supply
→ The current flowing to the Hall element is increased
- When connecting a pull-up resistor to the PWM pin.
→ Because the PWM pin must be set to low when in standby mode, the current flowing to the pull-up resistor is increased.
- When using an RD pin.
→ Because the RD pin is held low when in standby mode, the current flowing to the pull-up resistor is increased.

Timing Chart

Standby/Operate switchover

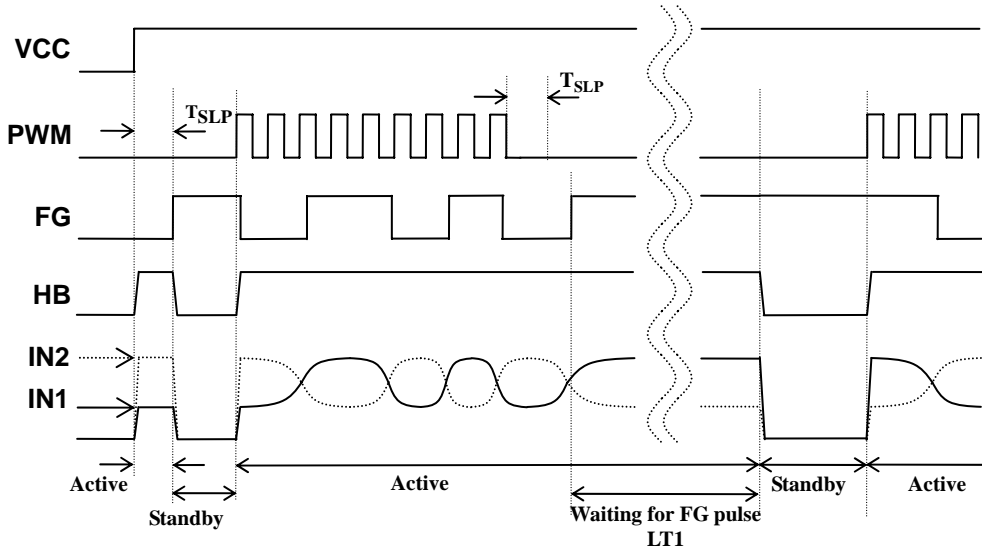

*1 $T_{SLP}=750\mu s(Typ)$

*2 If the PWM signal is held low during the TSLP period and no FG signal switching occurs during the LT1 period, the IC enters standby mode.

Only when the power is turned on, if the PWM signal is held low during the TSLP period, the IC enters standby mode.

*3 The FG pin is off and the RD pin is low in standby mode.

Lock protection

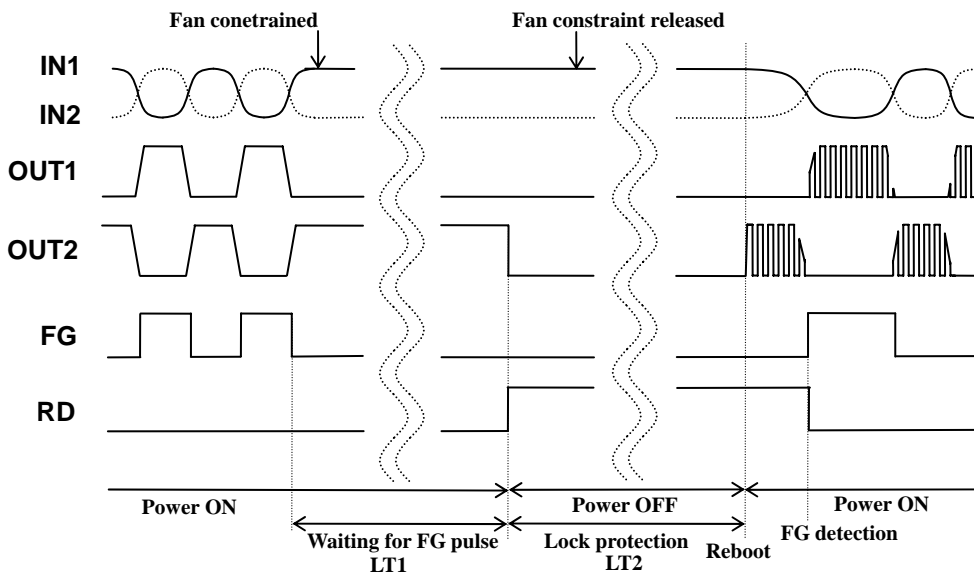

*1 Both OUT1 and OUT2 are low when lock protection mode is established.

*2 In the lock protection period, RD is set to off. After lock protection mode is released, RD is set to low when FG signal is switched (OFF → L or L → OFF)

*3 If PWM is held low for a period longer than the TSLP when lock protection mode is established, the IC enters standby mode.

*4 Driving starts at 50% duty cycle when the power is turned on, lock protection mode is released, or the IC is returned from standby mode. (period during which FG switches 5 or 6 times)

- SANYO Semiconductor Co.,Ltd. assumes no responsibility for equipment failures that result from using products at values that exceed, even momentarily, rated values (such as maximum ratings, operating condition ranges, or other parameters) listed in products specifications of any and all SANYO Semiconductor Co.,Ltd. products described or contained herein.
- SANYO Semiconductor Co.,Ltd. strives to supply high-quality high-reliability products, however, any and all semiconductor products fail or malfunction with some probability. It is possible that these probabilistic failures or malfunction could give rise to accidents or events that could endanger human lives, trouble that could give rise to smoke or fire, or accidents that could cause damage to other property. When designing equipment, adopt safety measures so that these kinds of accidents or events cannot occur. Such measures include but are not limited to protective circuits and error prevention circuits for safe design, redundant design, and structural design.
- In the event that any or all SANYO Semiconductor Co.,Ltd. products described or contained herein are controlled under any of applicable local export control laws and regulations, such products may require the export license from the authorities concerned in accordance with the above law.
- No part of this publication may be reproduced or transmitted in any form or by any means, electronic or mechanical, including photocopying and recording, or any information storage or retrieval system, or otherwise, without the prior written consent of SANYO Semiconductor Co.,Ltd.
- Any and all information described or contained herein are subject to change without notice due to product/technology improvement, etc. When designing equipment, refer to the "Delivery Specification" for the SANYO Semiconductor Co.,Ltd. product that you intend to use.
- Upon using the technical information or products described herein, neither warranty nor license shall be granted with regard to intellectual property rights or any other rights of SANYO Semiconductor Co.,Ltd. or any third party. SANYO Semiconductor Co.,Ltd. shall not be liable for any claim or suits with regard to a third party's intellectual property rights which has resulted from the use of the technical information and products mentioned above.

This catalog provides information as of September, 2011. Specifications and information herein are subject to change without notice.