

LMH2190

Quad Channel 27 MHz Clock Tree Driver with I²C Interface

General Description

The LMH2190 is a quad channel configurable clock tree driver which supplies a digital system clock to peripherals in mobile handsets or other applications. It provides a solution to clocking issues such as limited drive capability for fanout or longer traces, protection of the master clock from varying loads and frequency pulling effects, isolation buffering from noisy modules, and crosstalk isolation. It has very low phase noise which enables it to drive sensitive modules such as Wireless LAN and Bluetooth.

The LMH2190 can be clocked up to 27 MHz, and has an independent clock request pin for each clock output which allows the peripheral to control the clock. It features an integrated LDO which provides an ultra low noise voltage supply with 10 mA external load current which can be used to supply the TCXO or other clock source.

The I²C serial interface can be used to override the default configuration of the device to optimize the LMH2190 for the application. Some of these programmable features include setting the polarity of both the clock and the clock request inputs. In addition, the clock outputs have programmable output drive current to optimize for the connected load. EMI switching noise can be controlled by configuring output drive and skew settings.

The LMH2190 quad clock distributor is offered in a tiny 1.615mm x 1.615mm 16 bump microSMD package. Its small size and low supply current make it ideal for portable applications.

Features

- 1 input clock, 4 output clocks
- Supports both square or sine wave input
- 1.8V square wave clock outputs
- Skewed clock outputs
- Independent clock request
- High isolation of supply noise to clock input
- High output to output Isolation
- Output Drive up to 50 pF
- EMI controlled output edges and EMI filtering
- Integrated 1.8V Low-Dropout Regulator
 - Low Output Noise Voltage
 - 10 mA load current
- I²C Configurable up to 400 kHz (Fast Mode)
- Ultra low standby current
- V_{BAT} range = 2.5V to 5.5V

Applications

- Mobile handsets
- PDAs
- Portable Equipment

Typical Application

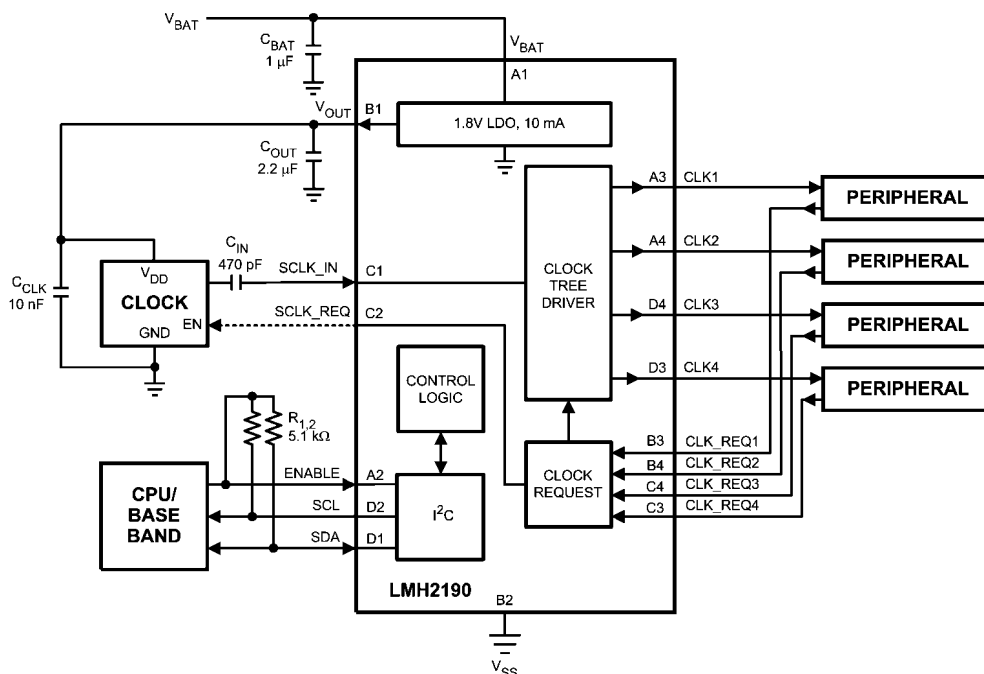

30083802

Absolute Maximum Ratings (Note 1)

If Military/Aerospace specified devices are required, please contact the National Semiconductor Sales Office/ Distributors for availability and specifications.

Supply Voltage		
$V_{BAT} - V_{SS}$		-0.3V to 6V
LVCMOS port IO voltage		-0.3V to ($V_{OUT} + 0.3V$)
Current on CLKx pins		+/- 65 mA
ESD Tolerance (Note 2)		
Human Body Model		2000V
Machine Model		200V
Storage Temperature Range		-65°C to 150°C
Junction Temperature (Note 3)		150°C
Maximum Lead Temperature (Soldering, 10 sec)		230°C

Operating Ratings (Note 1)

Supply Voltage ($V_{BAT} - V_{SS}$)	2.5V to 5.5V
V_{ENABLE}	0 to 2V
Input Clock, SCLK_IN	
DC Mode	32 kHz to 27 MHz
AC Mode	13 MHz to 27 MHz
Duty Cycle	45% to 55%
Temperature Range	-20°C to +85°C
Package Thermal Resistance θ_{JA} (Note 3)	113.6°C/W

3.5 V DC and AC Electrical Characteristics (Note 4, Note 11)

Unless otherwise specified, all limits are guaranteed at $T_A = 25^\circ\text{C}$, $V_{BAT} = 3.5\text{V}$, $f_{SCLK_IN} = 26\text{ MHz}$, $C_{OUT} = 2.2\ \mu\text{F}$, $V_{DD_IO} = 1.8\text{V}$ (See Block Diagram and (Note 9)), $I_{OUT} = 1\text{ mA}$, Registers are in default setting. **Boldface** limits apply at the temperature extremes.

Symbol	Parameter	Condition	Min (Note 6)	Typ (Note 5)	Max (Note 6)	Units
Supply Current (Note 8)						
I_{DD}	Active Supply Current	Clock outputs toggling at 26 MHz without external capacitors on CLK1/2/3/4, LDO is ON, $I_{OUT} = 0\text{ mA}$		3		mA
	Shutdown Supply Current	In Shutdown. No clocks toggling. LDO is OFF		0.1	1	μA
In Shutdown. Input CLK toggling, no Clock outputs toggling. LDO is OFF			0.1	1		
I_{DDQ}	Quiescent Supply Current	No Clock outputs toggling. LDO is ON, $I_{OUT} = 0\text{ mA}$		36	60	μA
		No Clock outputs toggling, LDO is ON, $I_{OUT} = 10\text{ mA}$		50	80	
I_{DDEN}	Current to Enable pin	I ² C port is operational			300	μA
		I ² C port is idle			0.1	
C_{PD}	Power Dissipation Capacitance per CLK output, (Note 7)	Defined with respect to $V_{OUT} = 1.8\text{V}$		15.7	17.5	pF
Clock Outputs (CLK1/2/3/4)						
t_{pLH}	Propagation Delay SCLK_IN to CLK1 - Low to High, Figure 1 (Note 7)	50% to 50%		6.5	10	ns
t_{pHL}	Propagation Delay SCLK_IN to CLK1 - High to Low, Figure 1 (Note 7)	50% to 50%		7.5	11	ns
t_{SKEW}	Skew Between Outputs (Either Edge), Figure 1, (Note 7)	CLK1 to CLK2, 50% to 50%	3	6	8.5	ns
		CLK2 to CLK3 and CLK3 to CLK4, 50% to 50%	1	3.5	7.3	
t_{RISE}	Rise Time, Figure 3, (Note 7, Note 13)	$C_L = 10\text{ pF}$ to 50 pF, 20% to 80%		3	6	ns
t_{FALL}	Fall Time, Figure 3, (Note 7, Note 13)	$C_L = 10\text{ pF}$ to 50 pF, 80% to 20%		2.5	5	
CLK_DC	Output Clock Duty Cycle, Figure 3, (Note 7)	$C_L = 10\text{ pF}$ to 50 pF	42	50	58	%

Symbol	Parameter	Condition	Min (Note 6)	Typ (Note 5)	Max (Note 6)	Units
Jitter _{RMS}	Additive RMS period Jitter	BW = 100 Hz to 1 MHz	CLK1		100	fs
			CLK2		240	
			CLK3		330	
			CLK4		400	
Phase Noise	CLK1 Additive Phase Noise with all Outputs toggling	f = 100 Hz		-130	dBc/Hz	
		f = 1 kHz		-144		
		f = 10 kHz		-152		
		f = 100 kHz		-158		
		f = 1 MHz		-165		
	CLK2 Additive Phase Noise with all Outputs toggling	f = 100 Hz		-128		
		f = 1 kHz		-139		
		f = 10 kHz		-146		
		f = 100 kHz		-151		
		f = 1 MHz		-153		
	CLK3 Additive Phase Noise with all Outputs toggling	f = 100 Hz		-127		
		f = 1 kHz		-138		
		f = 10 kHz		-144		
		f = 100 kHz		-148		
		f = 1 MHz		-150		
	CLK4 Additive Phase Noise with all Outputs toggling	f = 100 Hz		-125		
		f = 1 kHz		-135		
		f = 10 kHz		-142		
		f = 100 kHz		-147		
		f = 1 MHz		-148		
V _{OH}	CLK1/2/3/4 Output Voltage High Level	CLK1/2/3/4 = -2 mA	1.6			V
V _{OL}	CLK1/2/3/4 Output Voltage Low Level	CLK1/2/3/4 = 2 mA			0.2	
System Clock Input (SCLK_IN)						
V _{IH}	SCLK_IN Input Voltage High Level	DC Mode	0.65 x V _{OUT}		2.0	V
		AC Mode	1.2		1.8	
V _{IL}	SCLK_IN Input Voltage Low Level	DC Mode	0		0.35 x V _{OUT}	V
		AC Mode	0		0.6	
I _{IH}	SCLK_IN Input Current High Level	SCLK_IN = 1.8V, Clock path disabled		0	0.1	μA
I _{IL}	SCLK_IN Input Current Low Level	SCLK_IN = V _{SS} , Clock path disabled	-0.1	0		μA
C _{IN}	Input Capacitance (Note 7)			7.5	10	pF
V _{BIAS}	DC Bias Voltage	AC Mode		0.805		V
R _{IN}	Input Resistance	AC Mode, Clock path enabled.		21	30	kΩ

Symbol	Parameter	Condition	Min (Note 6)	Typ (Note 5)	Max (Note 6)	Units
Clock Request Output (SCLK_REQ)						
t_{pLH}	Propagation Delay, Push-Pull and Open Source, Figure 2 , (Note 7)	50% to 50%		21	32	ns
t_{pHL}	Propagation Delay, Push-Pull and Open Drain, Figure 2 , (Note 7)	50% to 50%		15	21	
V_{OH}	SCLK_REQ Output Voltage High Level	SCLK_REQ = -500 μ A, Push-Pull Output	1.52			V
		SCLK_REQ = -500 μ A, Open Source Output	1.52			
V_{OL}	SCLK_REQ Output Voltage Low Level	SCLK_REQ = 500 μ A, Push-Pull Output			0.2	V
		SCLK_REQ = 500 μ A, Open Drain Output			0.2	
Clock Request Inputs (CLK_REQ1/2/3/4)						
t_{SET}	Setup Time from CLK_REQx to SCLK_IN, to enable CLKx, Figure 4 , (Note 7)		16			ns
V_{IH}	CLK_REQ1/2/3/4 Input Voltage High Level		0.8 x V_{DD_IO}			V
V_{IL}	CLK_REQ1/2/3/4 Input Voltage Low Level				0.2 x V_{DD_IO}	V
I_{IH}	CLK_REQ1/2/3/4 Input Current High Level	200 k Ω internal pull down resistor. CLK_REQ1/2/3/4 = 1.8V		8.3	12.7	μ A
		Without internal / external pull down resistor. CLK_REQ1/2/3/4 = 1.8V		0	0.1	
I_{IL}	CLK_REQ1/2/3/4 Input Current Low Level	$V_{IL} = V_{SS}$	-0.1	0		μ A
SCL and SDA Inputs, $V_{ENABLE} = 1.8V$ (Note 10)						
V_{IH}	SCL and SDA Input Voltage High Level		0.8 x V_{ENABLE}			V
V_{IL}	SCL and SDA Input Voltage Low Level				0.2 x V_{ENABLE}	V
I_{IH}	SCL and SDA Input Current High Level	SCL/SDA = V_{ENABLE}		0	0.1	μ A
I_{IL}	SCL and SDA Input Current Low Level	100 k Ω internal Pull-up resistor, SCL/SDA = V_{SS}	-28	-18		μ A
V_{OL}	SDA Output Voltage Low Level	SDA = 3 mA			0.2	V
ENABLE Input						
V_{IH}	ENABLE Input Voltage High Level		1.65		2	V
V_{IL}	ENABLE Input Voltage Low Level				0.5	V
I_{IH}	ENABLE Input Current High Level	ENABLE = V_{OUT}			0.1	μ A
I_{IL}	ENABLE Input Current Low Level	ENABLE = V_{SS}	-0.1			μ A
LDO						
V_{OUT}	Output Voltage	$I_{OUT} = 1$ mA	1.78	1.805	1.82	V
I_{LOAD}	Load Current (Note 12)	$V_{OUT} > 1.74V$	0		10	mA
V_{DO}	Dropout Voltage (Note 14)	$V_{OUT} = 1.7V, I_{OUT} = 10$ mA		100	150	mV
I_{SC}	Short Circuit Current Limit			300		mA

Symbol	Parameter	Condition	Min (Note 6)	Typ (Note 5)	Max (Note 6)	Units	
PSRR	Power Supply Rejection Ratio	V_{BAT} ripple = 200 mV _{PP} , I_{OUT} = 10 mA	f = 100 Hz		93		dB
			f = 217.5 Hz		90		
			f = 1 kHz		78		
			f = 10 kHz		62		
			f = 50 kHz		54		
			f = 100 kHz		50		
			f = 1 MHz		42		
E_N	Output Noise Voltage	BW = 10Hz to 100 kHz, V_{BAT} = 4.2V, C_{OUT} = 2.2 μ F, All Outputs are Off		10		μ V _{RMS}	
T_{SHTDWN}	Thermal Shutdown	Temperature		160		°C	
		Hysteresis		20			
ΔV_{OUT}	Line Transient (Note 7)	V_{BAT} = ($V_{OUT(NOM)}$ + 1.0V) to ($V_{OUT(NOM)}$ + 1.6V) in 30 μ s	-1			mV	
		V_{BAT} = ($V_{OUT(NOM)}$ + 1.6V) to ($V_{OUT(NOM)}$ + 1.0V) in 30 μ s			1		
	Load Transient (Note 7)	I_{OUT} = 0 mA to 10 mA in 10 μ s	-70			mV	
		I_{OUT} = 10 mA to 0 mA in 10 μ s			30		
	Overshoot on Startup (Note 7)				100	mV	
R_{OUT}	DC Output Resistance			5		Ω	
T_{ON}	Turn on Time (Note 7)	to 95% of $V_{OUT(NOM)}$		185	270	μ s	

Note 1: Absolute Maximum Ratings indicate limits beyond which damage to the device may occur. Operating Ratings indicate conditions for which the device is intended to be functional, but specific performance is not guaranteed. For guaranteed specifications and the test conditions, see the Electrical Characteristics Tables.

Note 2: Human body model, applicable std. MIL-STD-883, Method 3015.7. Machine model, applicable std. JESD22-A115-A (ESD MM std of JEDEC). Field-Induced Charge-Device Model, applicable std. JESD22-C101-C. (ESD FICDM std. of JEDEC)

Note 3: The maximum power dissipation is a function of $T_{J(MAX)}$, θ_{JA} and T_A . The maximum allowable power dissipation at any ambient temperature is $P_D = (T_{J(MAX)} - T_A)/\theta_{JA}$. All numbers apply for packages soldered directly onto a PC board.

Note 4: Electrical Table values apply only for factory testing conditions at the temperature indicated. Factory testing conditions result in very limited self-heating of the device such that $T_J = T_A$. No guarantee of parametric performance is indicated in the electrical tables under conditions of internal self-heating where $T_J > T_A$.

Note 5: Typical values represent the most likely parametric norm as determined at the time of characterization. Actual typical values may vary over time and will also depend on the application and configuration. The typical values are not tested and are not guaranteed on shipped production material.

Note 6: Limits are 100% production tested at 25°C. Limits over temperature range are guaranteed through correlations using statistical quality control (SQC) method.

Note 7: This parameter is guaranteed by design and/or characterization and is not tested in production.

Note 8: I_{DD} current depends on switching frequency and load.

Note 9: V_{DD_IO} is equal to V_{OUT} when the LDO is enabled and it is equal to V_{ENABLE} when it is disabled.

Note 10: I²C interface uses IO cells guaranteed for 1.8V typical supply (1.6V Min - 2.0V Max).

Note 11: C_{BAT} , C_{OUT} : Low-ESR Surface-Mount Ceramic Capacitors (MLCCs) used in setting electrical characteristics.

Note 12: The device maintains stable, regulated output voltage without a load.

Note 13: Appropriate output load register must be set.

Note 14: Dropout voltage is the voltage difference between the supply voltage and the output voltage at which the output voltage drops to 100 mV below its nominal value.

Timing Waveforms

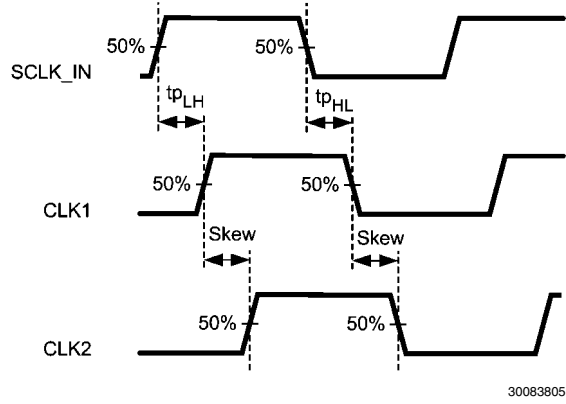

FIGURE 1. Clock Output Timing Waveforms

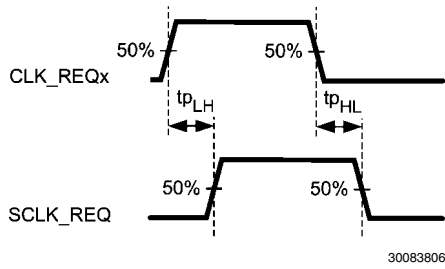

FIGURE 2. Clock Request Timing Waveforms

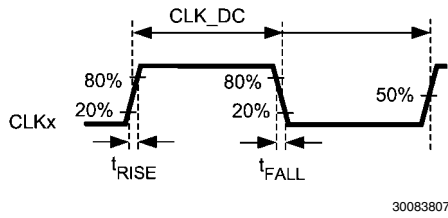

FIGURE 3. Rise / Fall Time and Duty Cycle Waveform for Clock Outputs

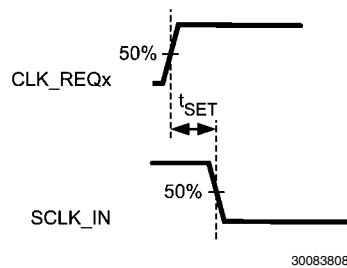
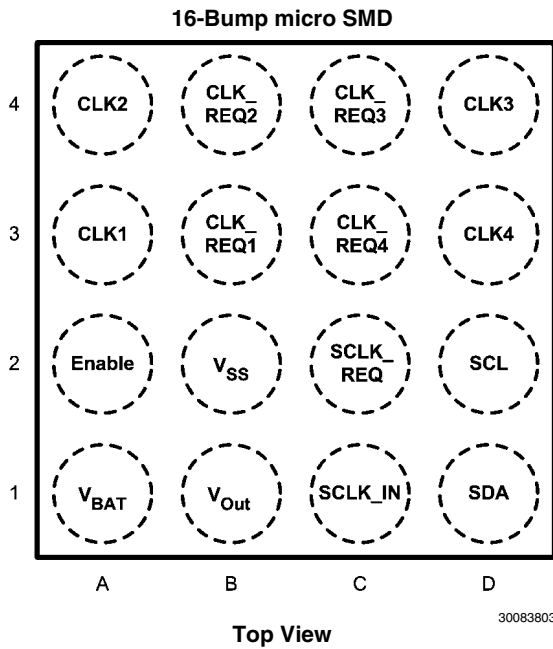
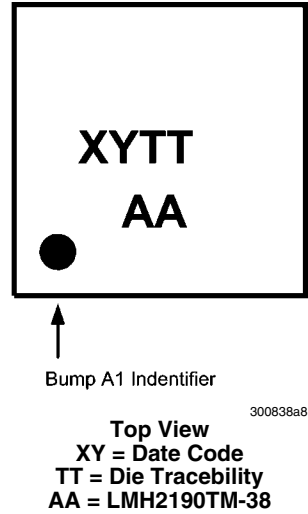

FIGURE 4. Setup Time from SCLK_IN to CLK_REQ

Connection Diagrams



16-Bump micro SMD Marking



Pin Descriptions

Pin	Pin Name	Port / Direction	Type	Description
C1	SCLK_IN	Host	I	Source Clock Input
C2	SCLK_REQ	Host	O	Source Clock Request
A3	CLK1	Peripheral	O	Clock Output 1
B3	CLK_REQ1	Peripheral	I	Clock Request Input 1
A4	CLK2	Peripheral	O	Clock Output 2
B4	CLK_REQ2	Peripheral	I	Clock Request Input 2
D4	CLK3	Peripheral	O	Clock Output 3
C4	CLK_REQ3	Peripheral	I	Clock Request Input 3
D3	CLK4	Peripheral	O	Clock Output 4
C3	CLK_REQ4	Peripheral	I	Clock Request Input 4
A2	ENABLE	Host	I	Enable Device, Active High
D2	SCL	Host	I	I ² C Clock Input, 100 kΩ Pull-up to ENABLE
D1	SDA	Host / Bidirectional	I/O	I ² C Data I/O, 100 kΩ Pull-up to ENABLE
A1	V _{BAT}	Battery / Input	Power	Power Supply
B1	V _{OUT}	LDO / Output	Power	Power Supply to Clock Source and Clock Outputs
B2	V _{SS}	Ground	Ground	Ground Pin

I = Input, O = Output, I/O = Input / Output

Ordering Information

Package	Part Number	I ² C Address	Package Marking	Transport Media	NSC Drawing
16-Bump Thin microSMD	LMH2190TM-38	38	AA	250 Units Tape and Reel	TMD16AAA
	LMH2190TMX-38			3000 Units Tape and Reel	

Note: For other I²C addresses please contact your local sales office.

Block Diagram

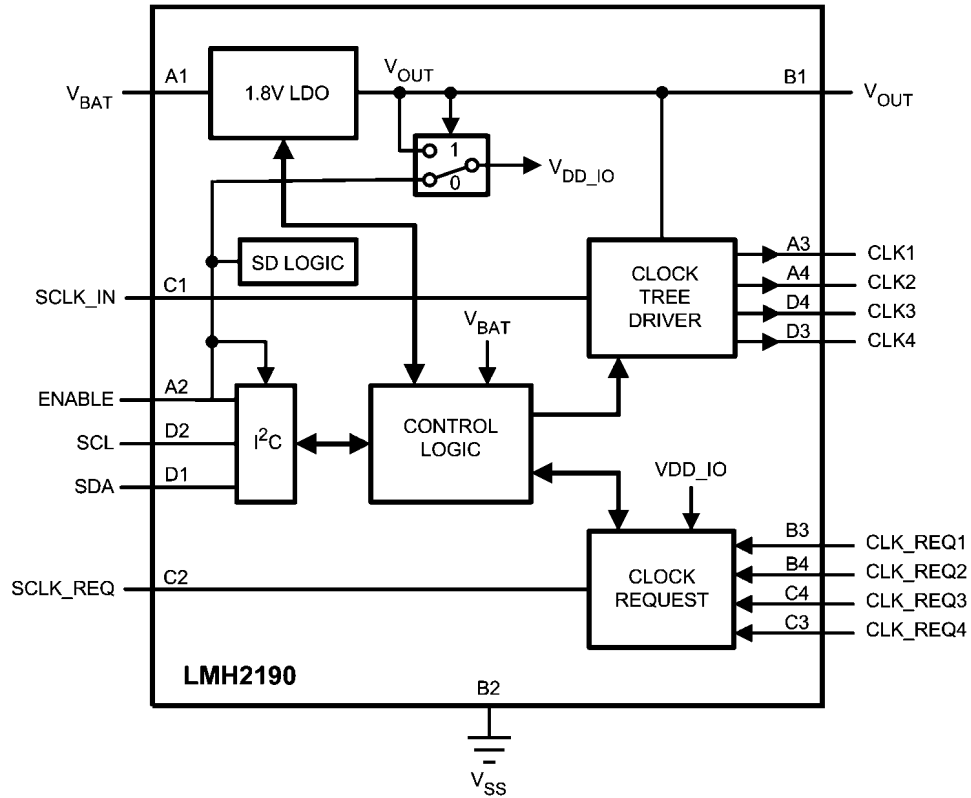

30083804

LMH2190

Typical Performance Characteristics Unless otherwise specified, $T_A = 25^\circ\text{C}$, $V_{\text{BAT}} = 3.5\text{V}$, $f_{\text{SCLK_IN}} = 26\text{ MHz}$, $C_{\text{OUT}} = 2.2\ \mu\text{F}$, $V_{\text{DD_IO}} = 1.8\text{V}$ (See *Block Diagram*), Registers are in default configuration.

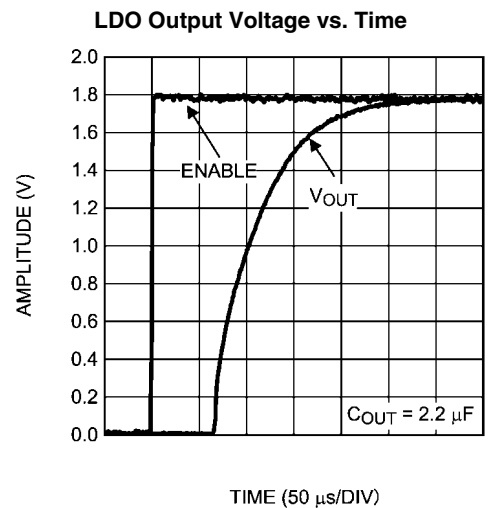
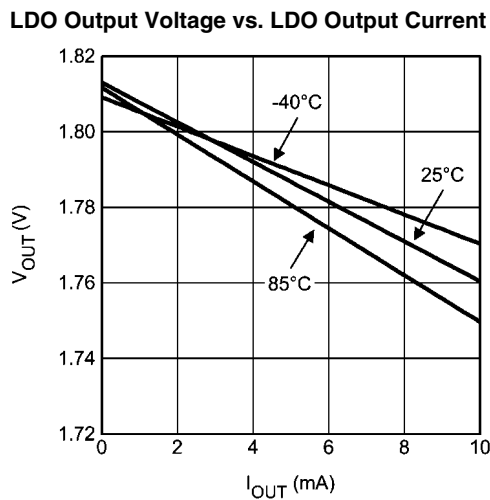
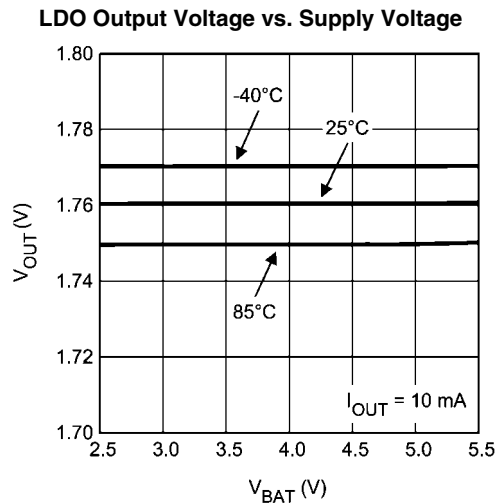
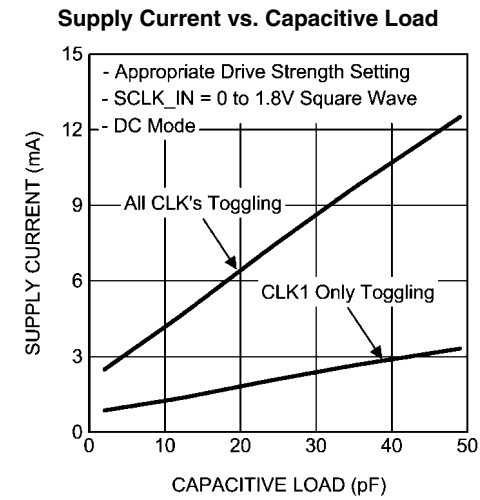
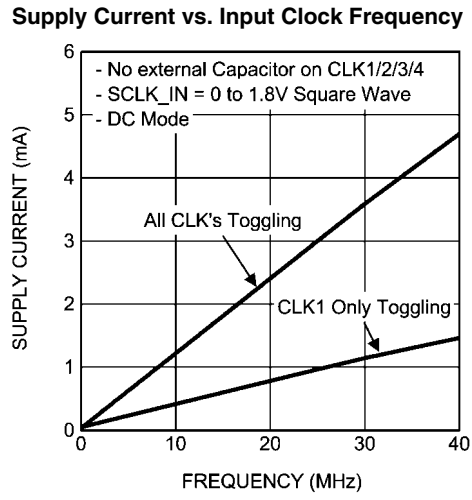
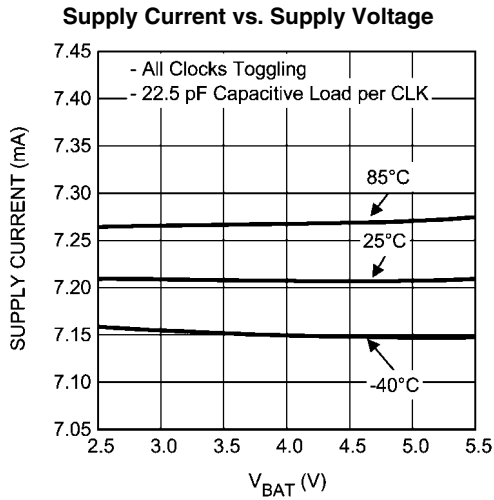

Additive Phase Noise vs. Frequency Offset

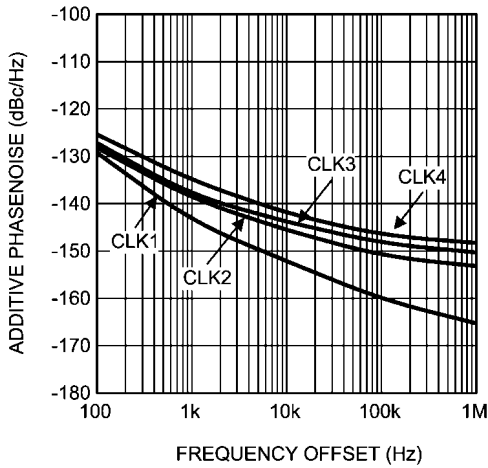

30083830

CLK1 Response, $C_L = 10\text{ pF}$

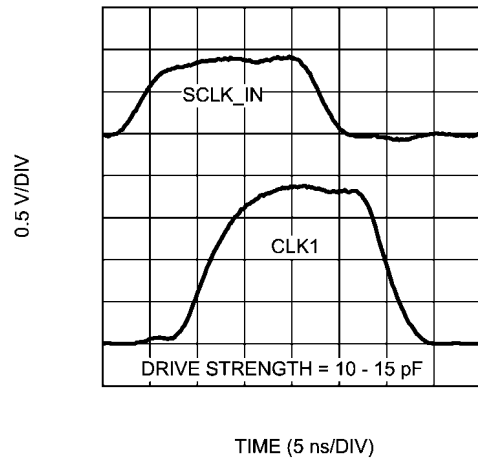

30083834

CLK1 Response, $C_L = 22\text{ pF}$

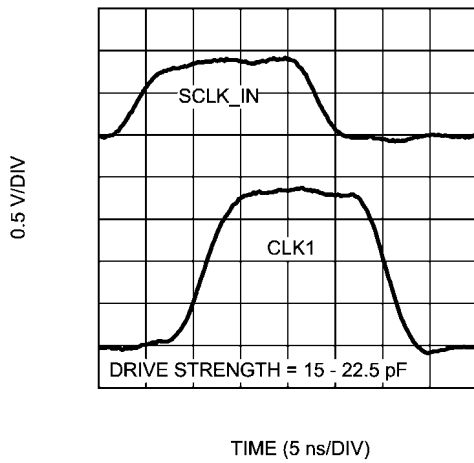

30083835

CLK1 Response, $C_L = 33\text{ pF}$

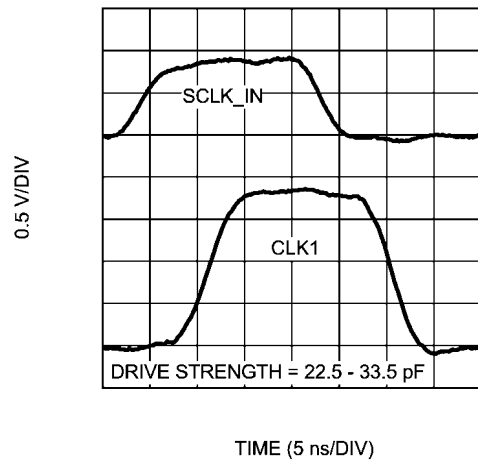

30083836

CLK1 Response, $C_L = 50\text{ pF}$

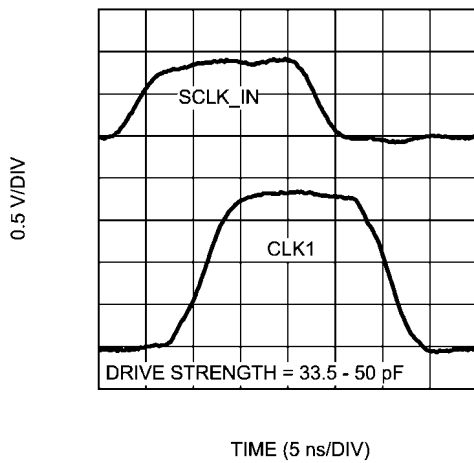

30083837

Power Supply Rejection Ratio vs. Frequency

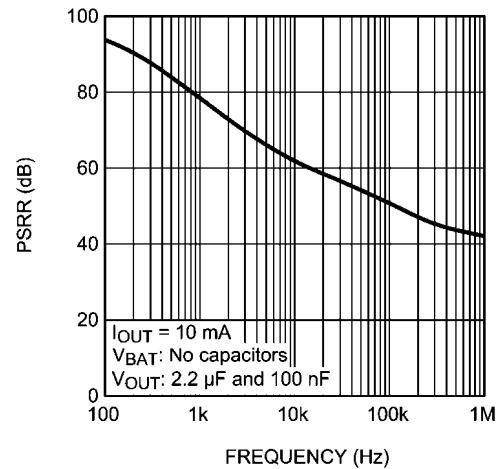

30083838

Application Information

The LMH2190 is a quad channel configurable clock distribution device which supplies a digital system clock to peripherals in mobile handsets or other applications. Examples of peripherals are Bluetooth, Wireless LAN, and/or Digital Video Broadcast-H (DVB-H).

The LMH2190 provides a solution to clocking issues such as limited drive capability, frequency pulling and crosstalk. The drive capability of a TCXO can be insufficient when traces are long and/ or multiple peripherals are connected to one TCXO. The LMH2190's clock outputs can be configured independently to drive capacitive loads up to 50 pF per channel. The buffer function of the LMH2190 prevents frequency pulling of the TCXO. Frequency pulling can occur when the TCXO observes varying loads. A peripheral device that shuts down can cause this load variation for instance. Crosstalk between peripheral devices is minimal since each peripheral has its own LMH2190 digital clock output. Also isolation from peripheral to TCXO is ensured by use of the LMH2190.

Adding a component in the clock path inherently means adding noise. The LMH2190 though has excellent phase noise specifications in order to minimize degradation of the clock quality. A typical LMH2190 application is depicted in Figure 5.

The LMH2190 clock tree driver can be divided into 4 blocks:

- Clock tree driver
The clock tree driver provides a clean clock to a maximum of 4 separately connected peripheral devices.
- Clock request logic
Independent clock request inputs allow the peripheral to control when the particular clock should be enabled. Further, the clock request inputs control the source clock request (SCLK_REQ) and enabling of the LDO.
- Low Dropout regulator (LDO)
The LDO provides a low noise, high PSRR supply voltage that enables low phase noise on the clock outputs, and low quiescent current for portable applications. It can also be used to provide a low noise supply to the TCXO eliminating the need for a separate LDO.
- I²C Control logic
An I²C control port enables re-configuration of settings of many features of the device in order to optimize the device performance based on the application. For these settings see Tables 2, 3, 4, 5, 6 in section *I²C Registers*.

All the blocks can be switched into a low power-consumption mode to save energy. This functionality is controlled via the ENABLE pin.

The following sections provide an explanation on phase noise and a detailed description of each block.

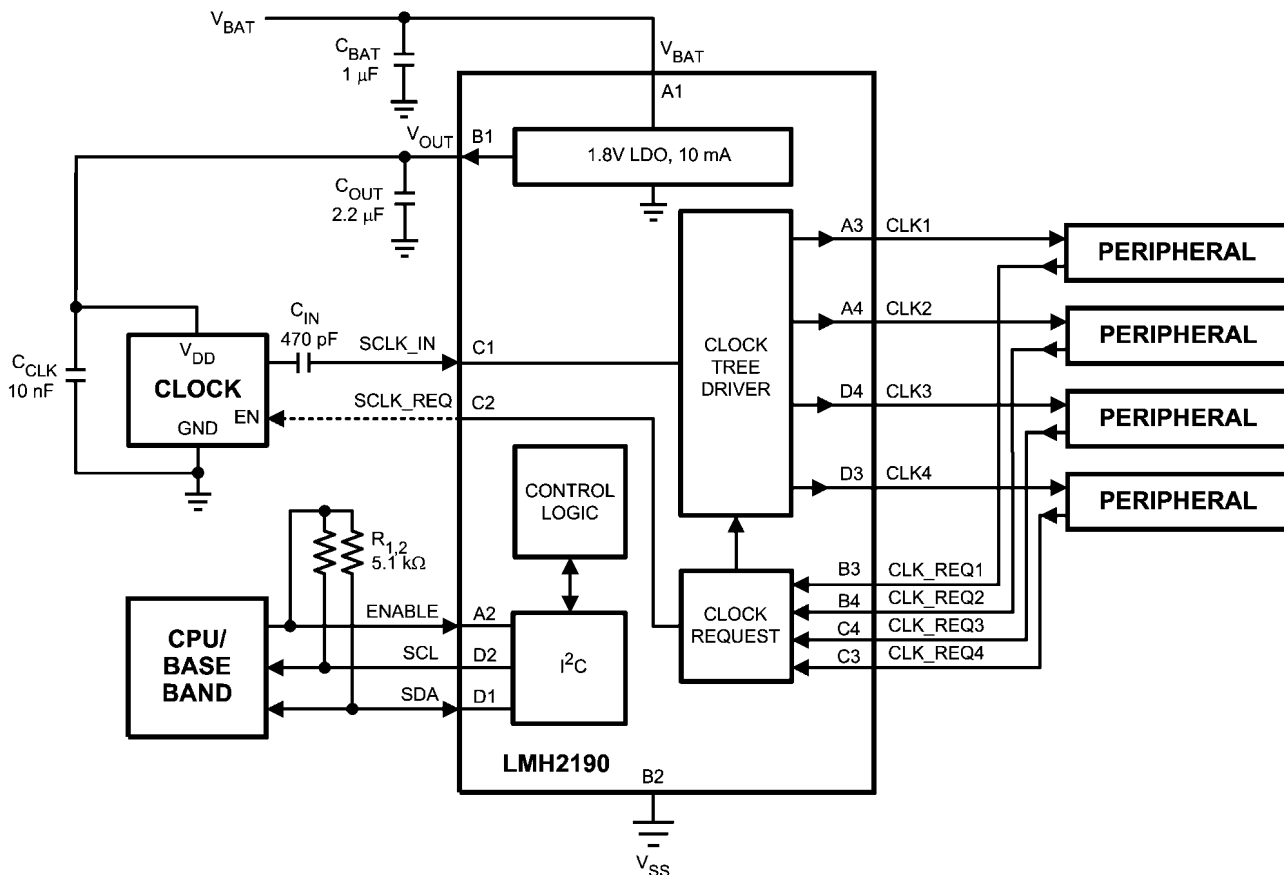

30083802

FIGURE 5. Typical LMH2190 Setup

PHASE NOISE

An important specification for oscillators and clock buffers is phase noise. It determines the timing and thus accuracy of various peripheral devices in a cell phone such as Bluetooth, WLAN and DVB-H.

Phase noise is expressed in the frequency domain and is usually specified at a number of offset frequencies from the carrier frequency. The phase noise of the oscillator and the LMH2190 together determine the phase noise of the clock that is distributed to the peripheral devices. Therefore an additive phase noise is specified for the LMH2190 rather than its total output phase noise since that depends on the TCXO connected to the LMH2190.

Knowing the TCXO phase noise and the additive phase noise of the LMH2190, the total phase noise to the peripheral can be calculated:

$$PN = 10 \text{ LOG} \left[10^{\frac{PN_TCXO}{10}} + 10^{\frac{\text{add.PN_LMH2190}}{10}} \right]$$

30083842

Where, PN is the total phase noise at the output of the LMH2190, PN_TCXO is the TCXO's phase noise and add.PN_LMH2190 is the additive phase noise of the LMH2190, all in dBc/Hz.

CLOCK TREE DRIVER

The clock tree driver consists of one input that drives 4 outputs (Figure 6). It is supplied by the highly accurate 1.8V LDO. In default configuration the outputs are switched on when the clock request inputs are high. The input as well as the output can be configured in several ways through I²C programming.

Clock Tree Driver Input

The source clock input (SCLK_IN) is the input for the clock tree driver. It can be configured to DC or AC coupled mode.

In shutdown mode, the input stage is completely switched off to prevent unnecessary power consumption when the source clock is still present.

In the DC coupled mode, the clock input may range from 32 kHz to 27 MHz. DC coupling mode requires that the input is a square wave.

In AC mode an external capacitor needs to be connected in series with the clock source and the SCLK_IN pin to block external DC. Internally, a DC bias network centers it at about V_{OUT}/2. This enables the use of a sine wave clock source with a amplitude between 0.8 V_{PP} and 1.8 V_{PP}. The bias voltage is enabled only when the clock request output is activated in order to eliminate the DC power. In the AC coupled mode, the clock input may range from 13 MHz up to 27 MHz. It is assumed to be a sine wave. Signals with sharp edges, such as square wave signals, should be prevented as the DC control loop will not be able to maintain its internal DC level.

Clock Tree Driver Outputs

The LMH2190's clock tree driver outputs have many modes of operation to reduce power consumption and minimize EMI. The output drive strength of the LMH2190 can be selected in 4 steps based on the load capacitance it needs to drive. The configuration can be done via the I²C interface.

There are two dedicated methods for reducing EMI that can be selected through the I²C interface. As shown in Figure 7 the first method (default) skews all of the clock edges individually, so that the EMI generated by the switching is spread out over time. The second method inverts two of the outputs and also skews one pair from the other.

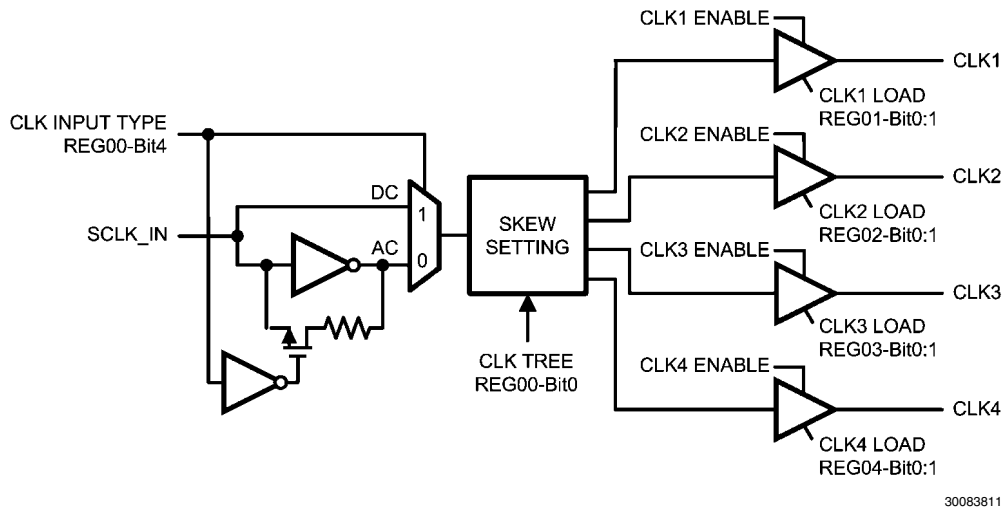

FIGURE 6. Clock Tree Driver

30083811

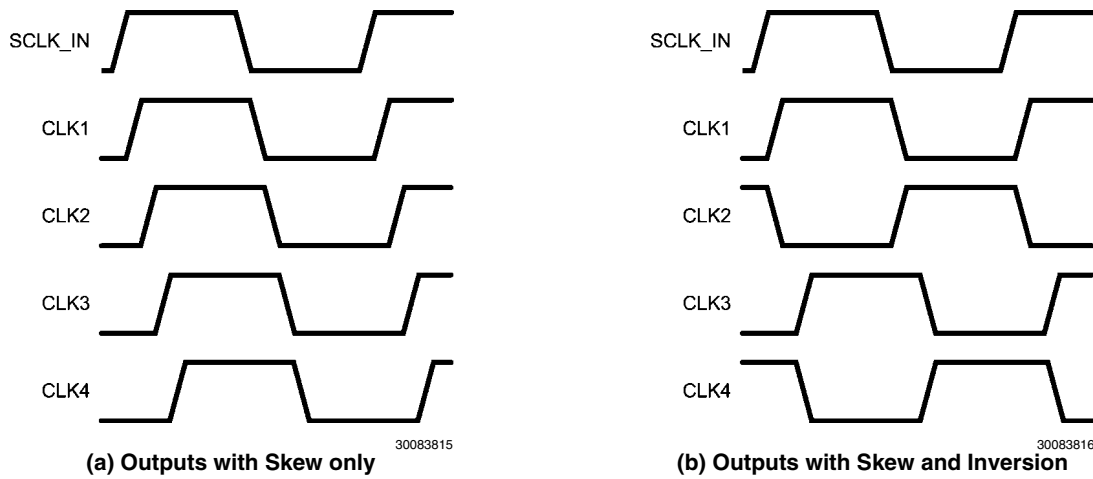

FIGURE 7. Clock Outputs Timing

CLOCK REQUEST LOGIC

The clock request logic enables an independent control of the clock tree driver outputs (CLK1 to CLK4) as well as an overall source clock request (SCLK_REQ) and LDO enabling. Since the clock request logic always needs to be active, it is supplied by either the output of the LDO (V_{OUT}) or by the external ENABLE. Further details about the selection between V_{OUT} and ENABLE can be found in the *LOW DROPOUT REGULATOR* section later in the datasheet.

Clock Request Inputs

A clock request input is provided for each clock output (Figure 8). This allows the peripheral device to control the LMH2190 when it wants to receive a clock. In case the peripheral device does not have clock request functionality, the CLK_x_REQ can

be wired to a logic high level to enable the clock output (in default register setting). Alternatively, it can be controlled through I²C. The CLK_x_REQ input can be configured to be active high or active low. When the LDO is off, the clock request logic still need to be powered such that it can turn on the LDO. This is why the ENABLE input is used to power the Clock Request Logic in case the LDO is off. Although the CLK_REQ logic is supplied with 1.8V LDO voltage (or ENABLE), the CLK_x_REQ input can tolerate voltages up to V_{BAT} .

To prevent glitches on CLK outputs, enabling of the outputs is done synchronously. A latch is used to ensure that the CLK outputs will be enabled on the falling edge of the source clock input (SCLK_IN).

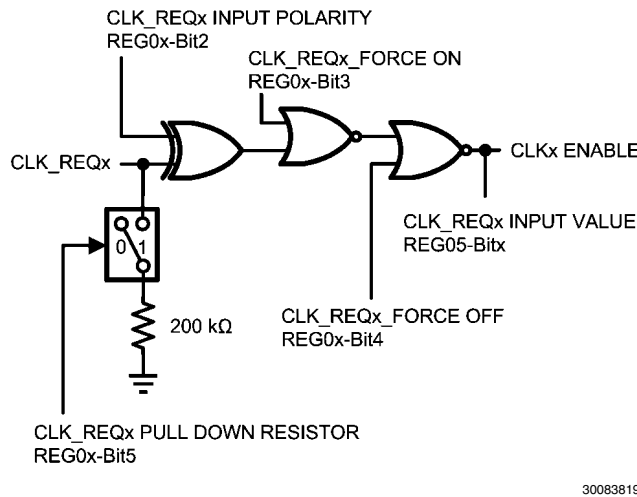

FIGURE 8. Clock Request Input

System Clock Request Output

In the typical mode of operation, the clock request output will be enabled if one of the 4 CLK_REQ inputs is high (Figure 9). However, this can be overridden via the I²C interface which has a register bit that forces the output to be enabled, independent of the CLK_REQ input. The polarity of the output can

be controlled via I²C (CLK_REQ Output Polarity) along with whether the output is configured as push/pull, open drain or open source.

For the open drain case, there needs to be an external resistor that pulls the SCLK_REQ to a high level. This high level may

be greater than the LDO voltage of 1.8V, but not more than the supply voltage (V_{BAT}) of the LMH2190.

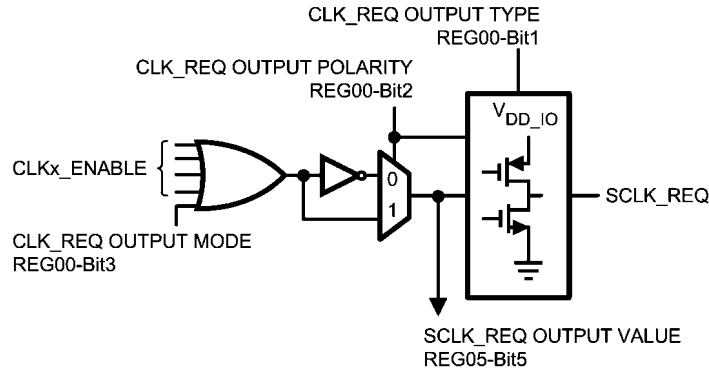

30083814

FIGURE 9. System Clock Request Output

The System Clock Request Output pin can be used to enable or disable an external TCXO to save power consumption. A typical application diagram is shown in *Figure 10*. The LDO powers the TCXO, while the SCLK_REQ enables or disables the TCXO. If the TCXO doesn't have an enable pin, power savings can be realized by switching off the LMH2190's LDO and therewith the TCXO.

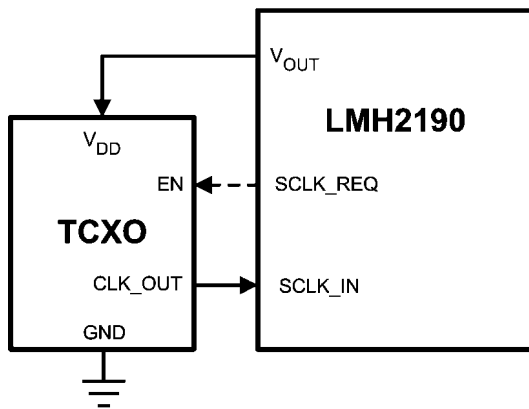

30083812

FIGURE 10. TCXO Powered from LMH2190's LDO

Note that the LMH2190 initializes to its default settings when V_{BAT} is powered-up. As a consequence, the LMH2190 is in its default state until it is configured through I²C. Because of

this configuration the CLK1/2/3/4 outputs may transmit the clock to a peripheral upon startup when it is not requested by the peripheral and before the device is initialized through the I²C port. This may happen for instance when the default settings of the device for SCLK_REQ and CLK_REQ1/2/3/4 polarities do not correspond to what is expected by the TCXO and the peripheral. Care must be taken to prevent any unwanted behavior in the peripheral device until the I²C port correctly configures the device. The setting of the registers is maintained as long as the V_{BAT} voltage is present.

LOW DROPOUT REGULATOR

The linear and low dropout regulator (LDO) is used to regulate the input voltage, V_{BAT} , to generate an accurate 1.8V supply voltage. This allows the LMH2190 to suppress V_{BAT} voltage ripples. A voltage ripple would distort clock edges causing phase noise on the distributed clock signal.

In default mode the LDO is powered-up when one or more Clock Request inputs are high. Therefore the Clock Request Logic needs to be powered continuously such that it can wake-up the LMH2190 and its LDO. The V_{DD_IO} voltage that takes care of supplying the Clock Request Logic can therefore be driven by either the LDO output voltage or the ENABLE signal. Normally the V_{DD_IO} signal is connected to the LDO output, unless the LDO is in a low power shutdown mode. In that case the ENABLE signal will drive V_{DD_IO} (*Figure 11*). As soon as there is a clock request, the built in LDO will power up and takes over the sourcing of V_{DD_IO} from the ENABLE signal.

edge clock pulse. The receiver must pull down the SDA line during the 9th clock pulse, signifying an acknowledge. A receiver which has been addressed must generate an acknowledge after each byte has been received.

After the START condition, the I²C master sends a chip address (Figure 14). This address is seven bits long followed by an eight bit which is a data direction bit (R/W). For the eighth bit, a "0" indicates a WRITE and a "1" indicates a READ. The second byte selects the register to which the data will be written. The third byte contains data to write to the selected register.

Register changes take effect at the SCL rising edge during the last ACK from slave. An example of a WRITE cycle is given in Figure 15. When a READ function is to be accomplished, a WRITE function must precede the READ function, as shown in the Read Cycle waveform (Figure 16).

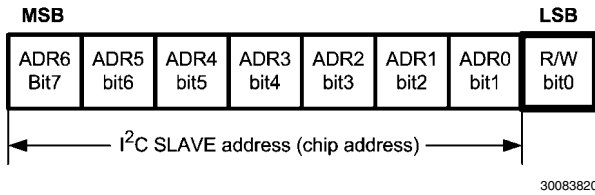

FIGURE 14. I²C Chip Address

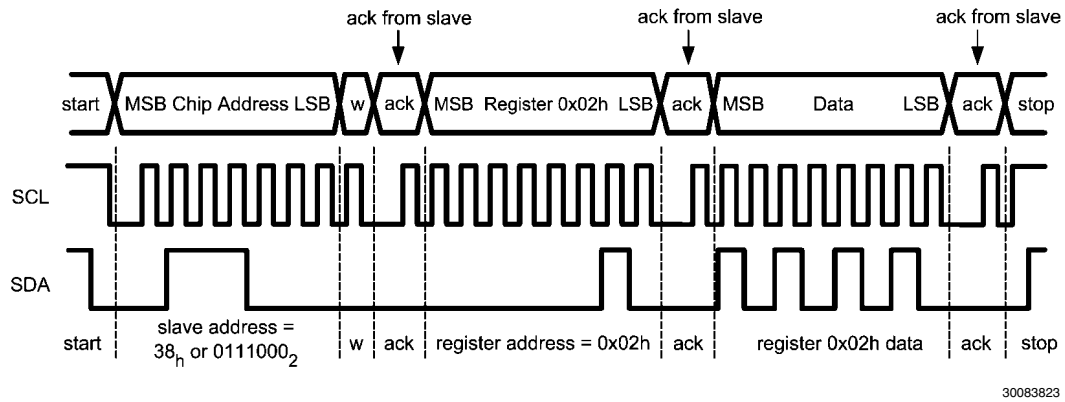

FIGURE 15. Example I²C Write Cycle

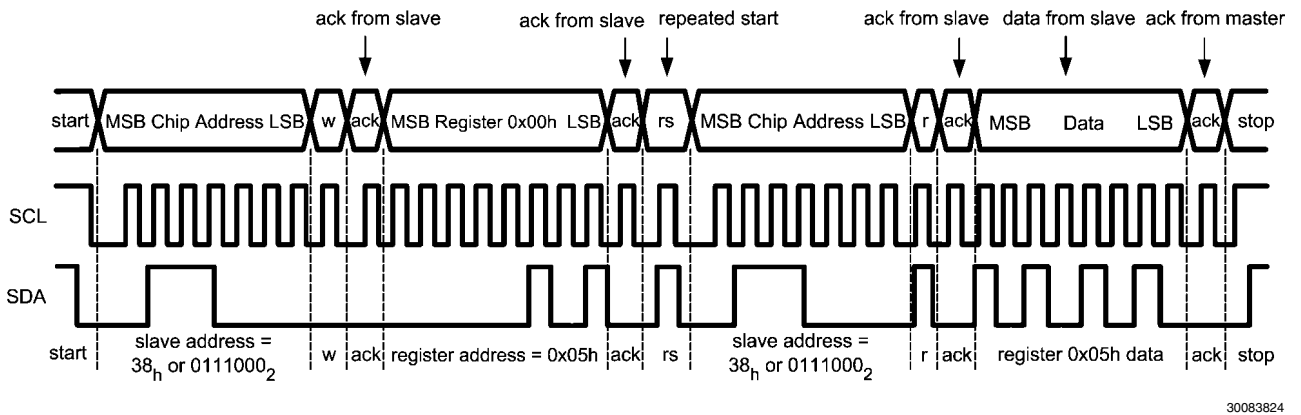

FIGURE 16. Example I²C Read Cycle

I²C Timing

The timing of the SDA and SCL signals is depicted in *Figure 17* and the parameters are given in *Table 1*.

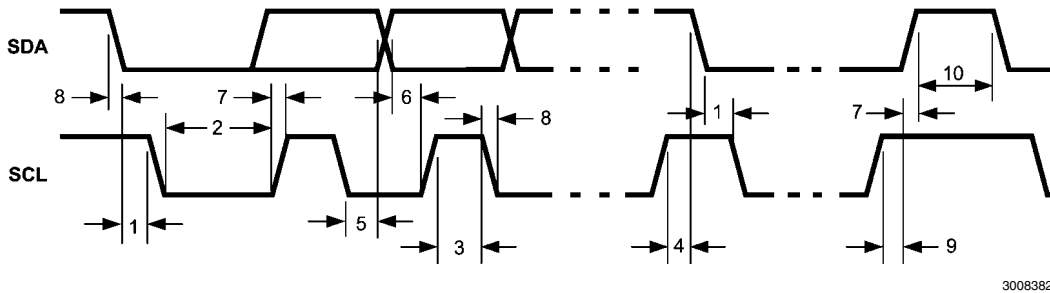

FIGURE 17. I²C Timing Diagram

TABLE 1. I²C Timing

Symbol	Parameter	Limit		Units
		Min	Max	
f_{SCL}	Clock Frequency		400	kHz
1	Hold Time (repeated) START Condition	0.6		μ s
2	Clock Low Time	1.3		ns
3	Clock High Time	600		ns
4	Setup Time for a Repeated START Condition	600		ns
5	Data Hold Time (Output direction, delay generated by LMH2190)	300	900	μ s
5	Data Hold Time (Input direction, delay generated by the Master)	0	900	ns
6	Data Setup Time	100		ns
7	Rise Time of SDA and SCL	$20+0.1 C_b$	300	ns
8	Fall Time of SDA and SCL	$10+0.1 C_b$	300	ns
9	Set-up Time for STOP condition	600		ns
10	Bus Free Time between a STOP and a START Condition	1.3		μ s
C_b	Capacitive Load for Each Bus Line	10	200	pF

I²C Registers

TABLE 2. Configuration Register

Address = 00H, type = R/W, reset value = 44H, 0100_0100, **Bold** face settings are the default configuration.

Field	Bits	Description
Output Mode	[0]	Sets the timing relationship of the clock outputs (<i>Figure 7</i>). 0 - All 4 outputs are skewed from each other 1 - Two pair of outputs where one output of the pair is the inversion of the other and the second pair is skewed from the first pair.
Clock Request Output Type	[1]	Sets whether the output is push-pull or open drain. 0 - Push-Pull Output 1 - Open Drain/Source Output (Open drain with Active low output, Open source with Active high output).
Clock Request Output Polarity	[2]	Sets whether the clock request output is active low or active high. 0 - Active low output 1 - Active high output
Clock Request Output Mode	[3]	Sets how the clock request output operates. 0 - Use clock request inputs 1 - Force the clock request output to be asserted.
Clock Input Type	[4]	Sets whether the input is AC or DC coupled. 0 - AC coupled 1 - DC coupled
LDO Mode	[6-5]	Sets the regulator mode of operation. 00 - OFF 01 - Reserved 10 - Track Clock Requests 11 - Force ON
Reserved	[7]	

TABLE 3. CLK1 Output Register

Address = 01H, type = R/W, reset value = 06H, 0000_0110, **Bold** face settings are the default configuration.

Field	Bits	Description
CLK1 Load	[1-0]	Sets the drive strength of the clock output based on the capacitive load. 00 - 10pF to 15pF 01 - 15pF to 22.5pF 10 - 22.5pF to 33.5pF 11 - 33.5pF to 50pF
CLK_REQ1 Input Polarity	[2]	Sets whether a logic low or high enables the clock output. 0 - Logic low enables the clock output. 1 - Logic high enables the clock output.
CLK_REQ1 Force ON Control	[3]	Selects whether to use a clock request or I ² C logic to enable the output. 0 - Use the clock request pin to control the output. 1 - Force the clock output to be enabled (Force ON).
CLK_REQ1 Force OFF Control	[4]	Selects whether to use a clock request or I ² C logic to disable the output. 0 - Use the clock request pin to control the output. 1 - Force the clock output to be disabled (Force OFF). "Force OFF" overrides "Force ON".
CLK_REQ1 Pull down Resistor	[5]	Selects whether an internal 200 k Ω pull down resistor on the clock request input to GND is present. 0 - No internal pull down resistor is present. 1 - Internal 200 k Ω pull-down resistor is present.
Reserved	[6]	
Reserved	[7]	

TABLE 4. CLK2 Output RegisterAddress = 02H, type = R/W, reset value = 06H, 0000_0110, **Bold** face settings are the default configuration.

Field	Bits	Description
CLK2 Load	[1-0]	Sets the drive strength of the clock output based on the capacitive load. 00 - 10pF to 15pF 01 - 15pF to 22.5pF 10 - 22.5pF to 33.5pF 11 - 33.5pF to 50pF
CLK_REQ2 Input Polarity	[2]	Sets whether a logic low or high enables the clock output. 0 - Logic low enables the clock output. 1 - Logic high enables the clock output.
CLK_REQ2 Force ON Control	[3]	Selects whether to use a clock request or I ² C logic to enable the output. 0 - Use the clock request pin to control the output. 1 - Force the clock output to be enabled (Force ON).
CLK_REQ2 Force OFF Control	[4]	Selects whether to use a clock request or I ² C logic to disable the output. 0 - Use the clock request pin to control the output. 1 - Force the clock output to be disabled (Force OFF). "Force OFF" overrides "Force ON".
CLK_REQ2 Pull down Resistor	[5]	Selects whether an internal 200 k Ω pull down resistor on the clock request input to GND is present. 0 - No internal pull down resistor is present. 1 - Internal 200 k Ω pull-down resistor is present.
Reserved	[6]	
Reserved	[7]	

TABLE 5. CLK3 Output RegisterAddress = 03H, type = R/W, reset value = 06H, 0000_0110, **Bold** face settings are the default configuration.

Field	Bits	Description
CLK3 Load	[1-0]	Sets the drive strength of the clock output based on the capacitive load. 00 - 10pF to 15pF 01 - 15pF to 22.5pF 10 - 22.5pF to 33.5pF 11 - 33.5pF to 50pF
CLK_REQ3 Input Polarity	[2]	Sets whether a logic low or high enables the clock output. 0 - Logic low enables the clock output. 1 - Logic high enables the clock output.
CLK_REQ3 Force ON Control	[3]	Selects whether to use a clock request or I ² C logic to enable the output. 0 - Use the clock request pin to control the output. 1 - Force the clock output to be enabled (Force ON).
CLK_REQ3 Force OFF Control	[4]	Selects whether to use a clock request or I ² C logic to disable the output. 0 - Use the clock request pin to control the output. 1 - Force the clock output to be disabled (Force OFF). "Force OFF" overrides "Force ON".
CLK_REQ3 Pull down Resistor	[5]	Selects whether an internal 200 k Ω pull down resistor on the clock request input to GND is present. 0 - No internal pull down resistor is present. 1 - Internal 200 k Ω pull-down resistor is present.
Reserved	[6]	
Reserved	[7]	

TABLE 6. CLK4 Output RegisterAddress = 04H, type = R/W, reset value = 06H, 0000_0110, **Bold** face settings are the default configuration.

Field	Bits	Description
CLK4 Load	[1-0]	Sets the drive strength of the clock output based on the capacitive load. 00 - 10pF to 15pF 01 - 15pF to 22.5pF 10 - 22.5pF to 33.5pF 11 - 33.5pF to 50pF
CLK_REQ4 Input Polarity	[2]	Sets whether a logic low or high enables the clock output. 0 - Logic low enables the clock output. 1 - Logic high enables the clock output.
CLK_REQ4 Force ON Control	[3]	Selects whether to use a clock request or I ² C logic to enable the output. 0 - Use the clock request pin to control the output. 1 - Force the clock output to be enabled (Force ON).
CLK_REQ4 Force OFF Control	[4]	Selects whether to use a clock request or I ² C logic to disable the output. 0 - Use the clock request pin to control the output. 1 - Force the clock output to be disabled (Force OFF). "Force OFF" overrides "Force ON".
CLK_REQ4 Pull down Resistor	[5]	Selects whether an internal 200 k Ω pull down resistor on the clock request input to GND is present. 0 - No internal pull down resistor is present. 1 - Internal 200 k Ω pull-down resistor is present.
Reserved	[6]	
Reserved	[7]	

TABLE 7. Status Register

Address = 05H, type = R

Field	Bits	Description
Thermal Shutdown (TSD)	[0]	Indicates if a thermal shutdown event has occurred. 0 - Thermal shutdown has not occurred. 1 - Thermal shutdown has occurred
CLK_REQ1 Input Value	[1]	Captures the state of the generated clock request input value. 0 - Generated clock request is low. 1 - Generated clock request is high.
CLK_REQ2 Input Value	[2]	Captures the state of the generated clock request input value. 0 - Generated clock request is low. 1 - Generated clock request is high.
CLK_REQ3 Input Value	[3]	Captures the state of the generated clock request input value. 0 - Generated clock request is low. 1 - Generated clock request is high.
CLK_REQ4 Input Value	[4]	Captures the state of the generated clock request input value. 0 - Generated clock request is low. 1 - Generated clock request is high.
SCLK_REQ Output Value	[5]	Captures the state of the system clock request output value. 0 - System clock request is low. 1 - System clock request is high.
Reserved	[6]	
Reserved	[7]	

LAYOUT RECOMMENDATIONS

As with any other device, careful attention must be paid to the board layout. If the board isn't properly designed, the performance of the device can be less than might be expected. Especially the input clock trace (SCLK_IN) and output traces (CLK1/2/3/4) should be as short as possible to reduce the capacitive load observed by the clock outputs. Also proper decoupling close to the device is necessary. Beside a capac-

itor in the μF range (See [Table 8](#)), a capacitor of 100 nF on V_{BAT} and V_{OUT} is recommended close to device. The equivalent series resistance (ESR) of the capacitors should be sufficiently low. A standard capacitor is usually adequate. Advised values are given in [Table 8](#). An evaluation board is available to ease evaluation and demonstrate a proper board layout.

TABLE 8. Recommended Component Values

Symbol	Parameter	Min	Typ	Max	Units
C_{BAT}	Capacitor on V_{BAT}	0.47	1		μF
C_{OUT}	Capacitor on V_{OUT}	1	2.2		
ESR	Equivalent Series Resistance	5		500	$\text{m}\Omega$
$C_{\text{SCLK_IN}}$	Input AC Coupling Capacitor	330	470	10000	pF

C_{BAT} , C_{OUT} : Low-ESR Surface-Mount Ceramic Capacitors (MLCC's) used in setting electrical characteristics.

Physical Dimensions inches (millimeters) unless otherwise noted

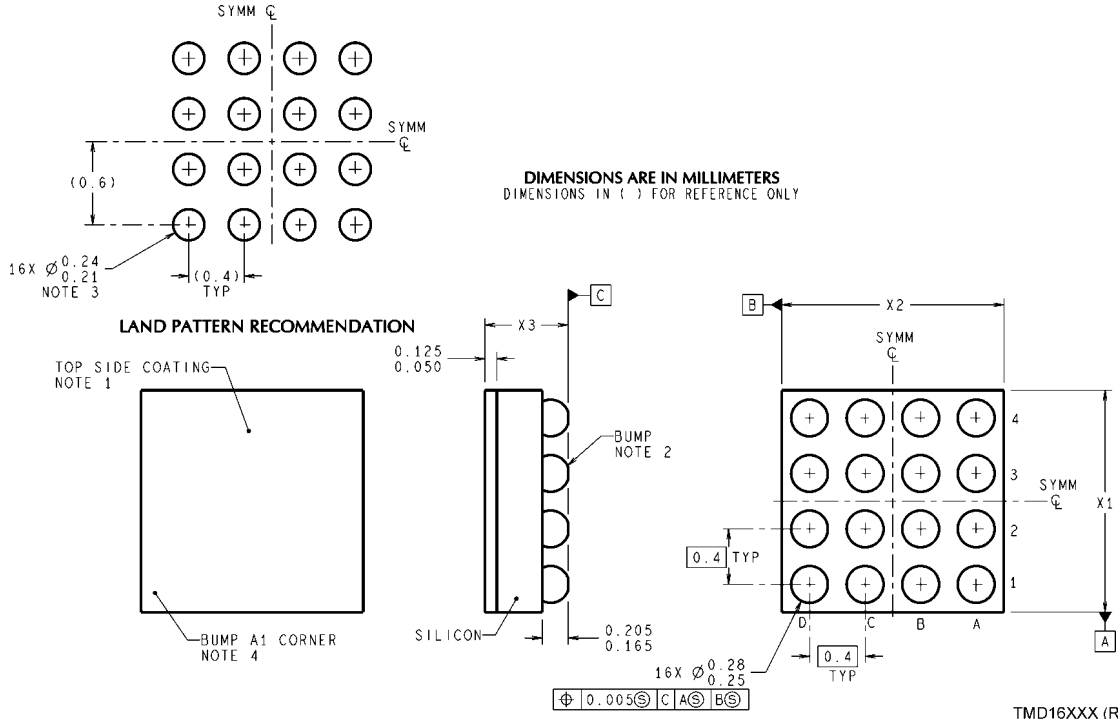

TMD16XXX (Rev A)

16-Bump micro SMD
NS Package Number TMD16AAA
X1 = 1.615 ± 0.030 mm, X2 = 1.615 ± 0.030 mm, X3 = 0.600 ± 0.075 mm

Notes

LMH2190

Notes

For more National Semiconductor product information and proven design tools, visit the following Web sites at:

Products		Design Support	
Amplifiers	www.national.com/amplifiers	WEBENCH® Tools	www.national.com/webench
Audio	www.national.com/audio	App Notes	www.national.com/appnotes
Clock and Timing	www.national.com/timing	Reference Designs	www.national.com/refdesigns
Data Converters	www.national.com/adc	Samples	www.national.com/samples
Interface	www.national.com/interface	Eval Boards	www.national.com/evalboards
LVDS	www.national.com/lvds	Packaging	www.national.com/packaging
Power Management	www.national.com/power	Green Compliance	www.national.com/quality/green
Switching Regulators	www.national.com/switchers	Distributors	www.national.com/contacts
LDOs	www.national.com/ldo	Quality and Reliability	www.national.com/quality
LED Lighting	www.national.com/led	Feedback/Support	www.national.com/feedback
Voltage Reference	www.national.com/vref	Design Made Easy	www.national.com/easy
PowerWise® Solutions	www.national.com/powerwise	Solutions	www.national.com/solutions
Serial Digital Interface (SDI)	www.national.com/sdi	Mil/Aero	www.national.com/milaero
Temperature Sensors	www.national.com/tempensors	SolarMagic™	www.national.com/solarmagic
Wireless (PLL/VCO)	www.national.com/wireless	PowerWise® Design University	www.national.com/training

THE CONTENTS OF THIS DOCUMENT ARE PROVIDED IN CONNECTION WITH NATIONAL SEMICONDUCTOR CORPORATION ("NATIONAL") PRODUCTS. NATIONAL MAKES NO REPRESENTATIONS OR WARRANTIES WITH RESPECT TO THE ACCURACY OR COMPLETENESS OF THE CONTENTS OF THIS PUBLICATION AND RESERVES THE RIGHT TO MAKE CHANGES TO SPECIFICATIONS AND PRODUCT DESCRIPTIONS AT ANY TIME WITHOUT NOTICE. NO LICENSE, WHETHER EXPRESS, IMPLIED, ARISING BY ESTOPPEL OR OTHERWISE, TO ANY INTELLECTUAL PROPERTY RIGHTS IS GRANTED BY THIS DOCUMENT.

TESTING AND OTHER QUALITY CONTROLS ARE USED TO THE EXTENT NATIONAL DEEMS NECESSARY TO SUPPORT NATIONAL'S PRODUCT WARRANTY. EXCEPT WHERE MANDATED BY GOVERNMENT REQUIREMENTS, TESTING OF ALL PARAMETERS OF EACH PRODUCT IS NOT NECESSARILY PERFORMED. NATIONAL ASSUMES NO LIABILITY FOR APPLICATIONS ASSISTANCE OR BUYER PRODUCT DESIGN. BUYERS ARE RESPONSIBLE FOR THEIR PRODUCTS AND APPLICATIONS USING NATIONAL COMPONENTS. PRIOR TO USING OR DISTRIBUTING ANY PRODUCTS THAT INCLUDE NATIONAL COMPONENTS, BUYERS SHOULD PROVIDE ADEQUATE DESIGN, TESTING AND OPERATING SAFEGUARDS.

EXCEPT AS PROVIDED IN NATIONAL'S TERMS AND CONDITIONS OF SALE FOR SUCH PRODUCTS, NATIONAL ASSUMES NO LIABILITY WHATSOEVER, AND NATIONAL DISCLAIMS ANY EXPRESS OR IMPLIED WARRANTY RELATING TO THE SALE AND/OR USE OF NATIONAL PRODUCTS INCLUDING LIABILITY OR WARRANTIES RELATING TO FITNESS FOR A PARTICULAR PURPOSE, MERCHANTABILITY, OR INFRINGEMENT OF ANY PATENT, COPYRIGHT OR OTHER INTELLECTUAL PROPERTY RIGHT.

LIFE SUPPORT POLICY

NATIONAL'S PRODUCTS ARE NOT AUTHORIZED FOR USE AS CRITICAL COMPONENTS IN LIFE SUPPORT DEVICES OR SYSTEMS WITHOUT THE EXPRESS PRIOR WRITTEN APPROVAL OF THE CHIEF EXECUTIVE OFFICER AND GENERAL COUNSEL OF NATIONAL SEMICONDUCTOR CORPORATION. As used herein:

Life support devices or systems are devices which (a) are intended for surgical implant into the body, or (b) support or sustain life and whose failure to perform when properly used in accordance with instructions for use provided in the labeling can be reasonably expected to result in a significant injury to the user. A critical component is any component in a life support device or system whose failure to perform can be reasonably expected to cause the failure of the life support device or system or to affect its safety or effectiveness.

National Semiconductor and the National Semiconductor logo are registered trademarks of National Semiconductor Corporation. All other brand or product names may be trademarks or registered trademarks of their respective holders.

Copyright© 2009 National Semiconductor Corporation

For the most current product information visit us at www.national.com



National Semiconductor Americas Technical Support Center
 Email: support@nsc.com
 Tel: 1-800-272-9959

National Semiconductor Europe Technical Support Center
 Email: europe.support@nsc.com

National Semiconductor Asia Pacific Technical Support Center
 Email: ap.support@nsc.com

National Semiconductor Japan Technical Support Center
 Email: jpn.feedback@nsc.com