

FEATURES

- Provides odd-HIGH parity of 12 inputs
- Extended 100E VEE range of -4.2V to -5.5V
- Output register with Shift/Hold capability
- 900ps max. D to Q, /Q output
- Enable control
- Asynchronous Register Reset
- Differential outputs
- Fully compatible with industry standard 10KH, 100K ECL levels
- Internal 75KΩ input pulldown resistors
- Fully compatible with Motorola MC10E/100E160
- Available in 28-pin PLCC package

DESCRIPTION

The SY10/100E160 are high-speed, 12-bit parity generator/checkers with differential outputs, for use in new, high-performance ECL systems. The output Q takes on a logic HIGH value only when an odd number of inputs are at a logic HIGH. A logic HIGH on the enable input (EN) forces the output Q to a logic LOW.

An additional feature of the E160 is the output register. Two multiplexers and their associated signals control the register input by providing the option of holding present data, loading the new parity data or shifting external data in. To hold the present data, the Hold signal (HOLD) must be at a logic LOW level. If the HOLD signal is at a logic HIGH, the data present at the Q output is passed through the first multiplexer. Taking the Shift signal (SHIFT) to a logic HIGH will shift the data at the S-IN pin into the output register. If the SHIFT signal is at a logic LOW, the output of the first multiplexer is then passed through to the register.

The register itself is clocked on the rising edge of CLK1 or CLK2 (or both). The presence of a logic HIGH on the reset pin (R) forces the register output Y to a logic LOW.

BLOCK DIAGRAM

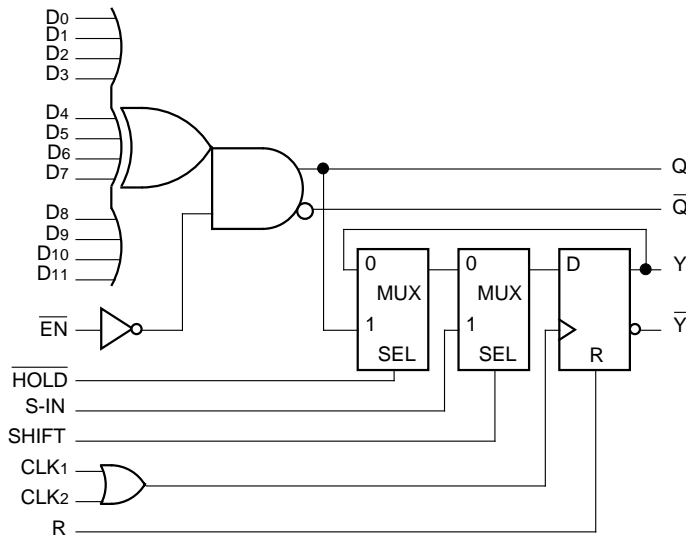

PACKAGE/ORDERING INFORMATION

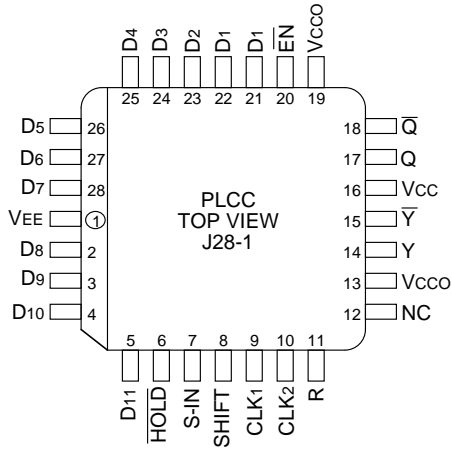

28-Pin PLCC (J28-1)

Ordering Information⁽¹⁾

Part Number	Package Type	Operating Range	Package Marking	Lead Finish
SY10E160JC	J28-1	Commercial	SY10E160JC	Sn-Pb
SY10E160JCTR ⁽²⁾	J28-1	Commercial	SY10E160JC	Sn-Pb
SY100E160JC	J28-1	Commercial	SY100E160JC	Sn-Pb
SY100E160JCTR ⁽²⁾	J28-1	Commercial	SY100E160JC	Sn-Pb
SY10E160JZ ⁽³⁾	J28-1	Commercial	SY10E160JZ with Pb-Free bar-line indicator	Matte-Sn
SY10E160JZTR ^(2, 3)	J28-1	Commercial	SY10E160JZ with Pb-Free bar-line indicator	Matte-Sn
SY100E160JZ ⁽³⁾	J28-1	Commercial	SY100E160JZ with Pb-Free bar-line indicator	Matte-Sn
SY100E160JZTR ^(2, 3)	J28-1	Commercial	SY100E160JZ with Pb-Free bar-line indicator	Matte-Sn

Notes:

1. Contact factory for die availability. Dice are guaranteed at T_A = 25°C, DC Electricals only.
2. Tape and Reel.
3. Pb-Free package is recommended for new designs.

PIN NAMES

Pin	Function
D0–D11	Data Inputs
S-IN	Serial Data Input
EN	Enable, active LOW
HOLD	Hold, active LOW
SHIFT	Shift, active HIGH
CLK1, CLK2	Clock Inputs
R	Reset Input
Q, \bar{Q}	Direct Output
Y, \bar{Y}	Register Output
Vcco	Vcc to Output

TRUTH TABLE

Number of HIGH Inputs	Output Q
Even	LOW
Odd	HIGH

DC ELECTRICAL CHARACTERISTICS

VEE = VEE (Min.) to VEE (Max.); VCC = VCCO = GND

Symbol	Parameter	TA = 0°C			TA = +25°C			TA = +85°C			Unit	Condition
		Min.	Typ.	Max.	Min.	Typ.	Max.	Min.	Typ.	Max.		
IIH	Input HIGH Current	—	—	200	—	—	200	—	—	200	μA	—
	CLK1, CLK2	—	—	300	—	—	300	—	—	300		
	R	—	—	150	—	—	150	—	—	150		
IEE	All Other Inputs	—	—	150	—	—	150	—	—	150	mA	—
	Power Supply Current	—	82	98	—	82	98	—	82	98		
	10E	—	82	98	—	82	98	—	82	98		
	100E	—	82	98	—	82	98	—	94	113		

AC ELECTRICAL CHARACTERISTICSV_{EE} = V_{EE} (Min.) to V_{EE} (Max.); V_{CC} = V_{CC0} = GND

Symbol	Parameter	T _A = 0°C			T _A = +25°C			T _A = +85°C			Unit	Condition
		Min.	Typ.	Max.	Min.	Typ.	Max.	Min.	Typ.	Max.		
t _{PD}	Propagation Delay to Output D to Q	400	650	950	400	650	950	400	650	950	ps	—
	EN to Q	300	550	750	300	550	750	300	550	750		
	CLK to Y	275	500	700	275	500	700	275	500	700		
	R to Y	275	500	725	275	500	725	275	500	725		
t _s	Set-up Time D	1200	900	—	1200	900	—	1200	900	—	ps	—
	HOLD	600	300	—	600	300	—	600	300	—		
	S-IN	350	150	—	350	150	—	350	150	—		
	SHIFT	500	250	—	500	250	—	500	250	—		
t _H	Hold Time D	-400	-900	—	-400	-900	—	-400	-900	—	ps	—
	HOLD	100	-300	—	100	-300	—	100	-300	—		
	S-IN	300	-150	—	300	-150	—	300	-150	—		
	SHIFT	200	-250	—	200	-250	—	200	-250	—		
t _r t _f	Rise/Fall Time 20% to 80%	300	450	650	300	450	650	300	450	650	ps	—

28-PIN PLCC (J28-1)

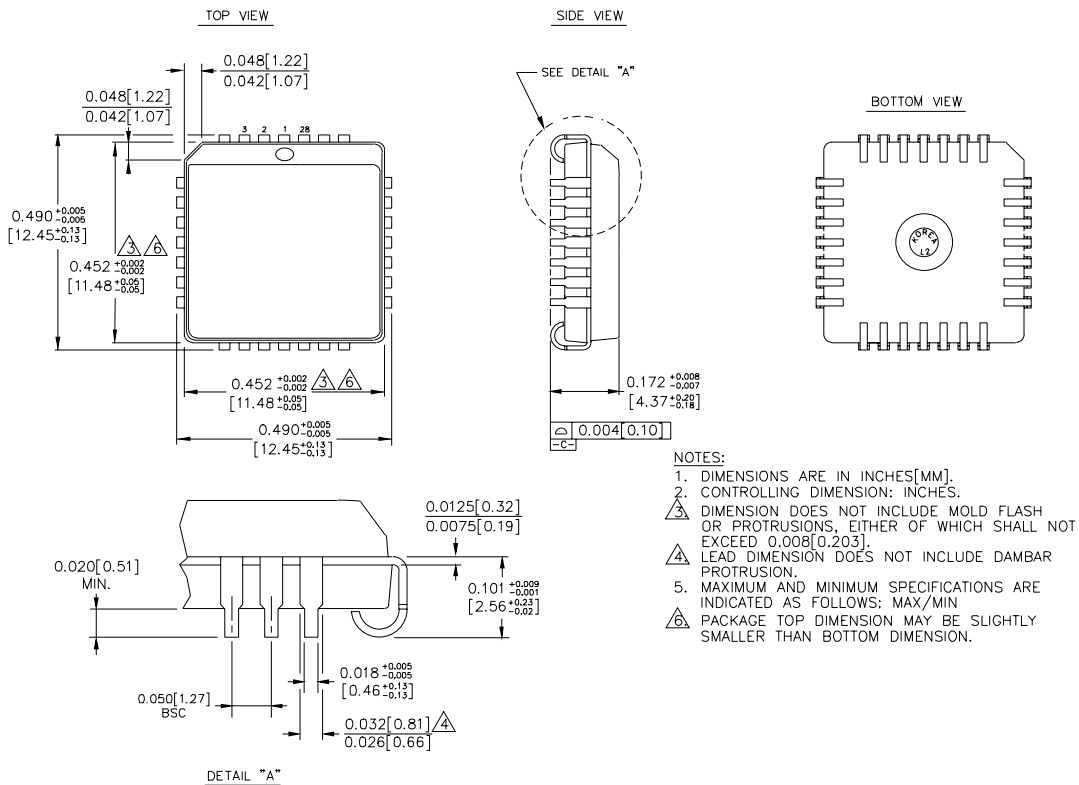

Rev. 03

MICREL, INC. 2180 FORTUNE DRIVE SAN JOSE, CA 95131 USA

TEL + 1 (408) 944-0800 FAX + 1 (408) 474-1000 WEB <http://www.micrel.com>

The information furnished by Micrel in this data sheet is believed to be accurate and reliable. However, no responsibility is assumed by Micrel for its use. Micrel reserves the right to change circuitry and specifications at any time without notification to the customer.

Micrel Products are not designed or authorized for use as components in life support appliances, devices or systems where malfunction of a product can reasonably be expected to result in personal injury. Life support devices or systems are devices or systems that (a) are intended for surgical implant into the body or (b) support or sustain life, and whose failure to perform can be reasonably expected to result in a significant injury to the user. A Purchaser's use or sale of Micrel Products for use in life support appliances, devices or systems is at Purchaser's own risk and Purchaser agrees to fully indemnify Micrel for any damages resulting from such use or sale.

© 2006 Micrel, Incorporated.