

PRELIMINARY SPEC

Features:

- HIGH LUMINANCE OUTPUT.
- DESIGN FOR HIGH CURRENT OPERATION.
- UNIFORM COLOR.
- LOW POWER CONSUMPTION.
- LOW THERMAL RESISTANCE.
- LOW PROFILE.
- PACKAGED IN TUBES FOR USE WITH AUTOMATIC INSERTION EQUIPMENT.
- SOLDERING METHODS: WAVE SOLDERING
- RoHS COMPLIANT.



ATTENTION
OBSERVE PRECAUTIONS
FOR HANDLING
ELECTROSTATIC
DISCHARGE
SENSITIVE
DEVICES

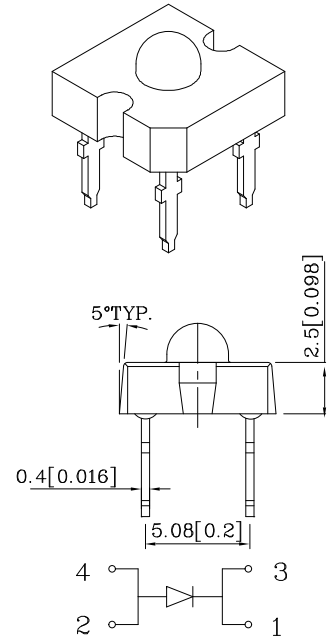
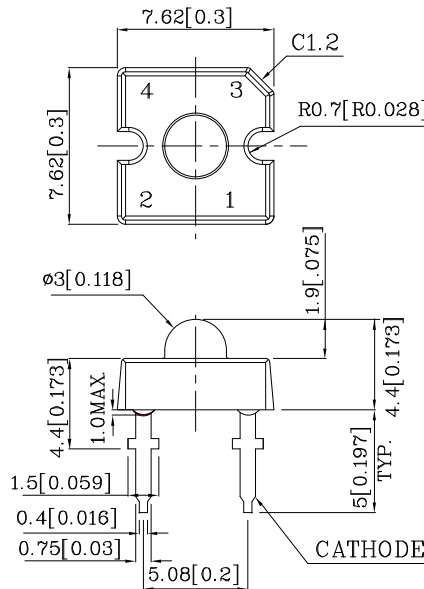

Notes:

1. All dimensions are in millimeters (inches).
2. Tolerance is $\pm 0.25(0.01)$ " unless otherwise noted.
3. Specifications are subject to change without notice.

Benefits:

- *Outstanding Material Efficiency.
- *Electricity savings.
- *Maintenance savings.
- *Reliable and Rugged.

Typical Applications:

- *Automotive Exterior Lighting.
- *Electronic Signs and Signals.
- *Specialty Lighting.

Absolute maximum ratings (TA=25°C)		M2BG (InGaN)	Unit
Reverse Voltage	VR	5	V
Forward Current	IF	50	mA
Power Dissipation	PT	210	mW
Operating Temperature	TA	-40 ~ +85	°C
Storage Temperature	Tstg	-55 ~ +85	
Electrostatic Discharge Threshold (HBM)		1000	V
Lead Solder Temperature [1.5mm(0.06inch)Below Seating Plane.]		260°C For 5 Seconds	

Operating Characteristics (TA=25°C)		M2BG (InGaN)	Unit
Forward Voltage (Typ.) (IF=50mA)	VF	3.5	V
Forward Voltage (Max.) (IF=50mA)	VF	4.2	V
Reverse Current (Max.) (VR=5V)	IR	10	uA
Wavelength of Peak Emission (Typ.) (IF=50mA)	λP	525	nm
Wavelength of Dominant Emission (Typ.) (IF=50mA)	λD	535	nm
Spectral Line Full Width At Half-Maximum (Typ.) (IF=50mA)	$\Delta\lambda$	39	nm
Capacitance (Typ.) (VF=0V, f=1MHz)	C	65	pF
Thermal Resistance (Typ.)	R θ j-pin	130	°C/W

1.No Reflow soldering .

Part Number	Emitting Color	Emitting Material	Lens-color	Luminous Intensity (If=50mA) med		Wavelength nm λ P	Viewing Angle 2 θ 1/2
				Min.	typ.		
SM2BG883W	Green	InGaN	Water Clear	10000	22990	525	40°

1. LUMINOUS INTENSITY IS MEASURED WITH AN INTEGRATING SPHERE AFTER THE DEVICE HAS STABILIZED.
 2. θ 1/2 IS THE ANGLE FROM OPTICAL CENTERLINE WHERE THE LUMINOUS INTENSITY IS 1/2 THE OPTICAL CENTERLINE VALUE.

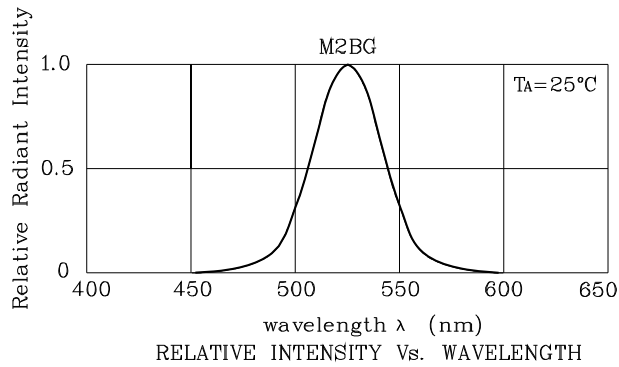

❖ **M2BG**

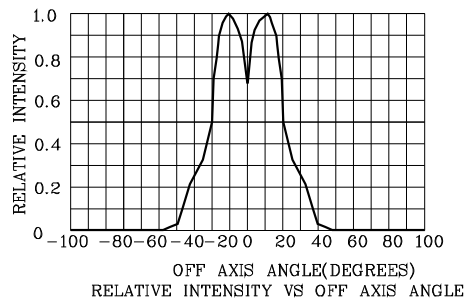
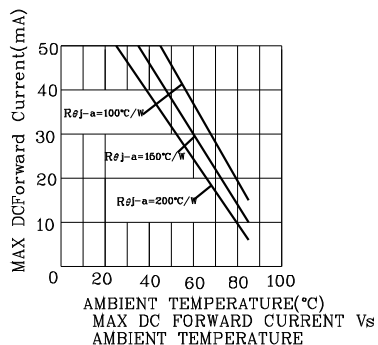
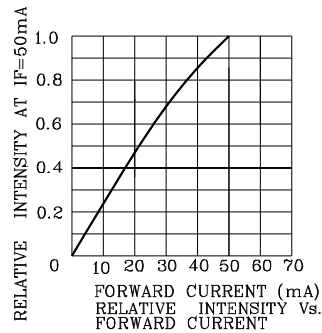
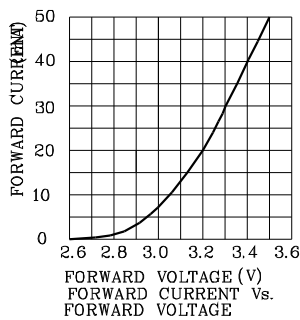

Wave Soldering Profile For Lead-free Through-hole LED.

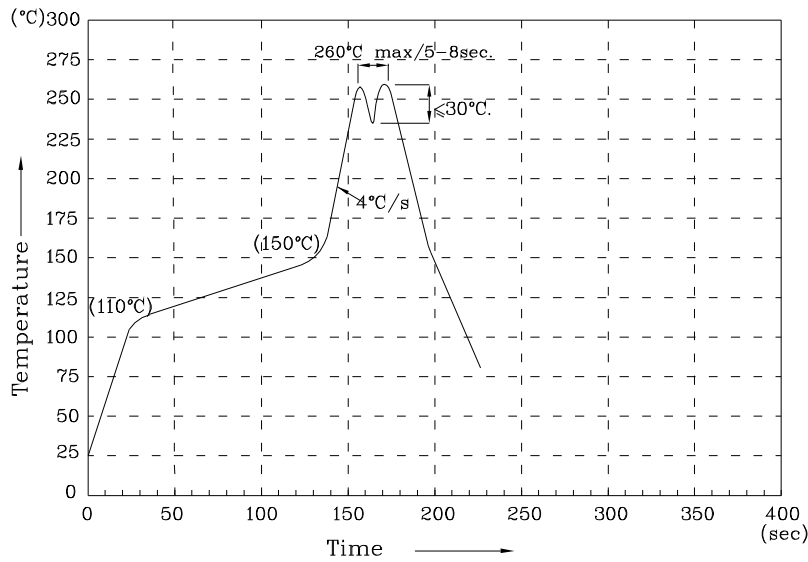

NOTES:

1. Recommend the wave temperature 245°C~260°C. The maximum soldering temperature should be less than 260°C.
2. Do not apply stress on epoxy resins when temperature is over 85 degree°C.
3. The soldering profile apply to the lead free soldering (Sn/Cu/Ag alloy).
4. No more than once.

Remarks:

If special sorting is required (e.g. binning based on forward voltage, luminous intensity / luminous flux or wavelength), the typical accuracy of the sorting process is as follows:

1. Wavelength: +/-1nm
2. Luminous Intensity / Luminous Flux: +/-15%
3. Forward Voltage: +/-0.1V

Note: Accuracy may depend on the sorting parameters.



PACKING & LABEL SPECIFICATIONS

SM2BG883W

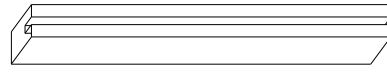
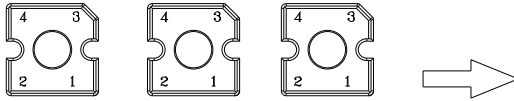

75PCS/IC TUBE

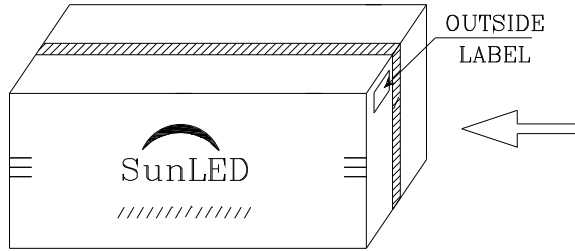

24K/ BOX

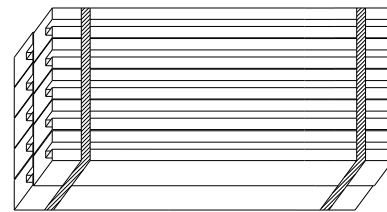

750pcs/10pcs IC TUBE



P/NO : Sxxx883x	
QTY : 750 pcs	CODE: XXX
S/N : XX	
LOT NO:	
 XXXXXXXXXXXXXXXXXXXXXXXX	
RoHS Compliant	