

**Data Sheet****VSC8061/VSC8062****2.5Gb/s 16-Bit  
Multiplexer/Demultiplexer Chipset****Features**

- Serial Data Rate up to 2.5Gb/s
- 16-Bit Wide ECL 100K Compatible Parallel Data Interface
- Differential High-Speed Data Outputs
- Differential or Single-Ended High-Speed Data and Clock Inputs
- On-Chip Phase Detector (VSC8061 Multiplexer)
- Power Dissipation: VSC8061:2.0W(max), VSC8062: 1.7W(max)
- Standard ECL Power Supplies:  $V_{EE} = -5.2V$ ,  $V_{TT} = -2.0V$
- Commercial (0°C to +70°C) or Industrial (-40°C to +85°C) Temperature Range
- Available in 52-Pin Ceramic Leaded Chip Carrier or 52-Pin Plastic Quad Flat Pack Packages

**Functional Description**

The VSC8061 and VSC8062 are high-speed interface devices capable of data rates up to 2.5Gb/s. The devices are fabricated in gallium arsenide using the Vitesse H-GaAs E/D MESFET process to achieve high-speed and low power dissipation. For ease of system design using these products, both devices use industry-standard -5.2V and -2V power supplies, and have ECL-compatible I/O for parallel data interfaces. Typical applications include telecommunication transmission and instrumentation.

**VSC8061 Multiplexer**

The VSC8061 consists of a 16:1 multiplexer circuit, a phase detector, and a timing circuit which generates a divide-by-16 clock from the high-speed clock input. The 16:1 multiplexer accepts 16 parallel single-ended ECL compatible inputs (D0...D15) at data rates up to 156Mb/s and bitwise serializes them into a 2.5Gb/s serial output (DO/DON). The internal timing of the VSC8061 is referenced to the negative going edge of the high-speed clock true input (CLK). This clock is divided by 16 and is provided as an output (CLK16/CLK16N). The setup and hold time of the parallel inputs (D[0:15]) are specified with respect to the falling edge of CLK16, so that CLK16/CLK16N can be used to clock the data source of D[0:15]. The on-chip phase detector monitors the phase relationship between the internally generated divide-by-16 clock and an externally supplied low-speed reference clock input (DCLK/DCLKN). Phase difference between these two clock signals generates an up or down output (U, D) for phase lock applications. The phase detector can be used as part of an external Phase Locked Loop (PLL) to implement a clock multiplication function.

In applications where a 2.5GHz system clock is provided, and the phase detector function is not required, it is recommended to connect one side of the DCLK/DCLKN input to  $V_{TT}$  through a 50Ω resistor. The U and D output can be left open and unused.

**VSC8062 Demultiplexer**

The VSC8062 consists of a 1:16 demultiplexer and timing circuitry which generates a divide-by-16 clock from the high-speed clock input. The demultiplexer accepts a serial data stream input (DI/DIN) at up to 2.5Gb/s and deserializes it into 16 parallel single-ended ECL compatible outputs (D[0:15]) at data rates up to 156 Mb/s. The internal timing of the VSC8062 is referenced to the negative going edge of the high-speed clock true input (CLK). This clock is divided by 16 and provided as an output (CLK16/ CLK16N). The timing parameters of the parallel data outputs (D[0:15]) are specified with respect to the falling edge of CLK16, so that CLK16/CLK16N can be used to clock the destination of D[0:15].

**Figure 1: VSC8061 Block Diagram**

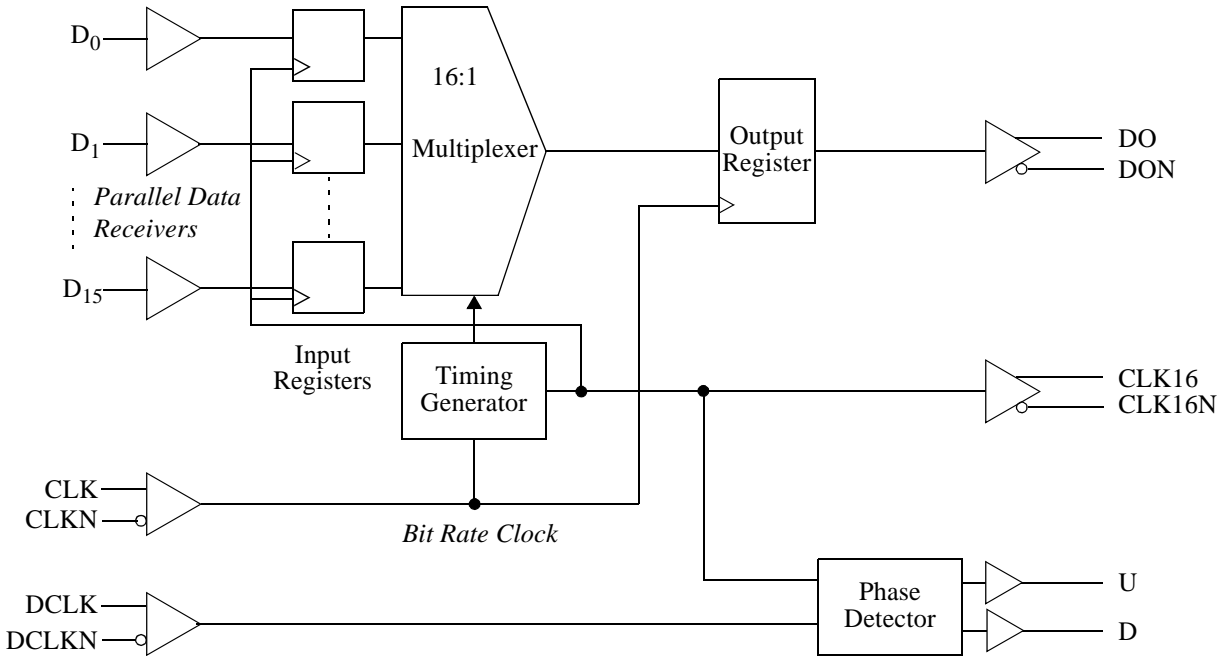

**Figure 2: VSC8062 Block Diagram**

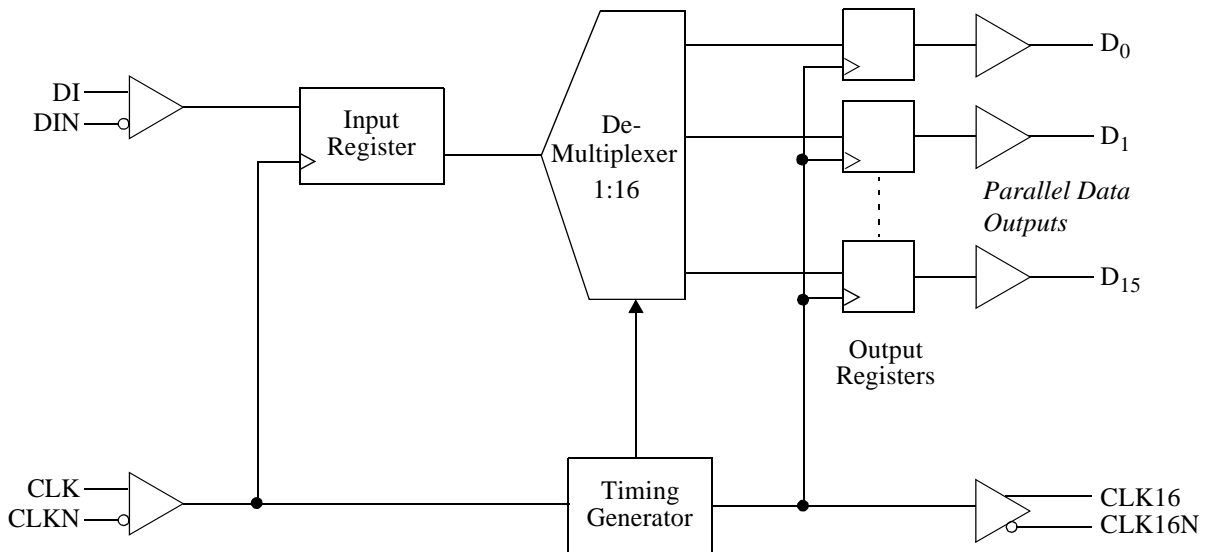

### VSC8061 Multiplexer AC Characteristics (Over recommended operating range)

Figure 3: VSC8061 Multiplexer Waveforms

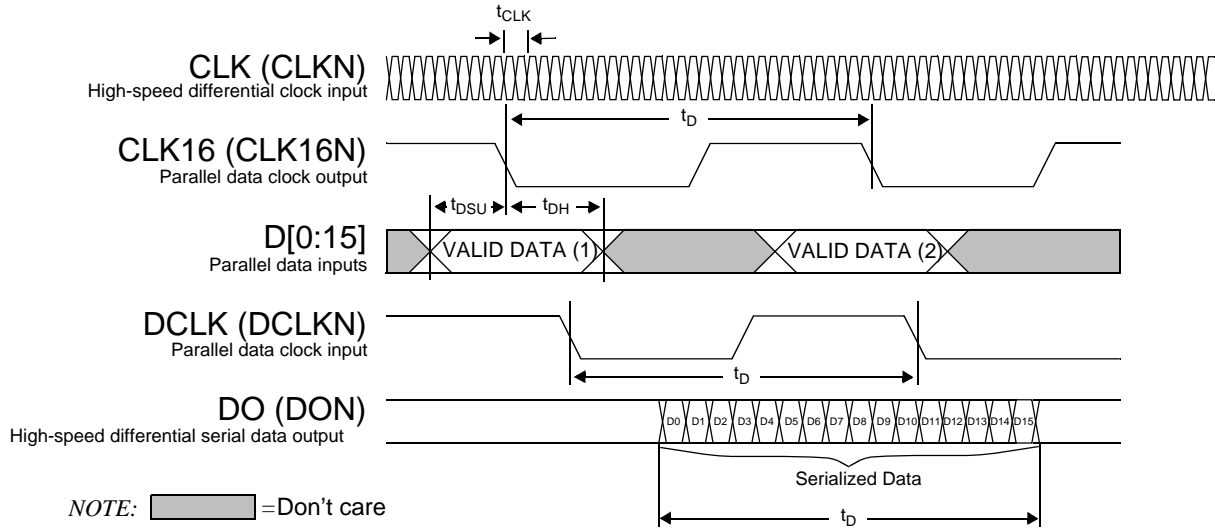

Table 1: VSC8061 AC Characteristics

Parameter	Description	Min	Typ	Max	Units	Conditions
$t_{CLK}$	Clock period <sup>(1)</sup>	400			ps	
$t_D$	CLK16, DCLK period ( $t_{CLK} \times 16$ )	6.4		15.6	ns	
$t_{DSU}$	Parallel data set-up time with respect to CLK16 falling edge	2.0			ns	
$t_{DH}$	Data hold time with respect to CLK16 falling edge	0.5			ns	
$t_{DC}$	CLK16 duty cycle	40		60	%	
$t_R, t_F$	DCLK (DCLKN) rise and fall times			1.5	ns	10% to 90%
$t_R, t_F$	D[0:15] rise and fall times			2.0	ns	10% to 90%
$t_R, t_F$	CLK16 (CLK16N) rise and fall times		0.5	1.0	ns	10% to 90%
$t_R, t_F$	DO (DON) rise and fall times		150	165	ps	20% to 80%

NOTE: (1) Devices are guaranteed to operate to a maximum frequency of 2.5GHz.

**VSC8061 Phase Detector Logic Diagram**

The internal phase detector of the VSC8061 compares the phase difference between the internally generated divide-by-16 clock and the DCLK input. If both inputs (CLK16 and DCLK) to the phase detector are in phase, the U and D outputs will both be low. If the rising edge of CLK16 precedes DCLK, a series of pulses with pulse widths proportional to the phase difference will be present at the U output. Conversely, if DCLK precedes CLK16, then a series of pulses with widths proportional to the phase difference will be present at the D output. The Phase Detector ignores phase differences for falling edges. This circuitry is useful for implementing a Clock Multiplier Unit (CMU) function with the VSC8061. For example, the DCLK can be the system reference clock at the parallel data rate. An external Voltage Controlled Oscillator (VCO) at 16x the frequency of the reference clock can be used as the CLK input for the VSC8061. The phase detector outputs (U and D) can then be used by an external integrator to generate an output that controls the VCO. The generated 16x clock from the VCO will be phase-locked to the reference clock.

**Figure 4: VSC8061 Phase Detector Logic Diagram**

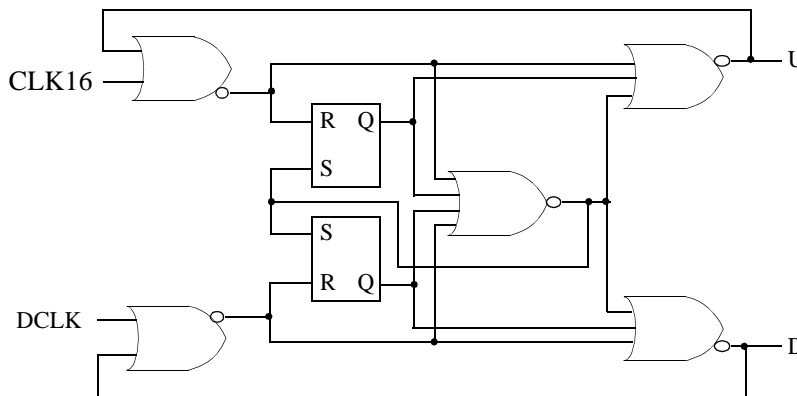

**Figure 5: Phase Detector Input and Output Waveforms**

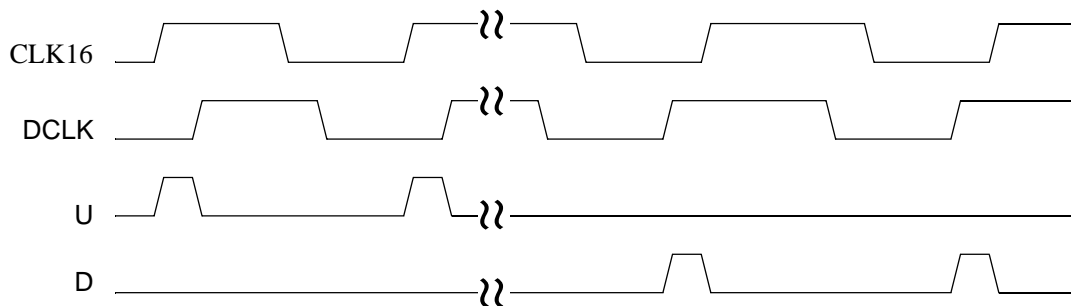

### VSC8062 Demultiplexer AC Characteristics (Over recommended operating range)

Figure 6: VSC8062 Timing Diagram

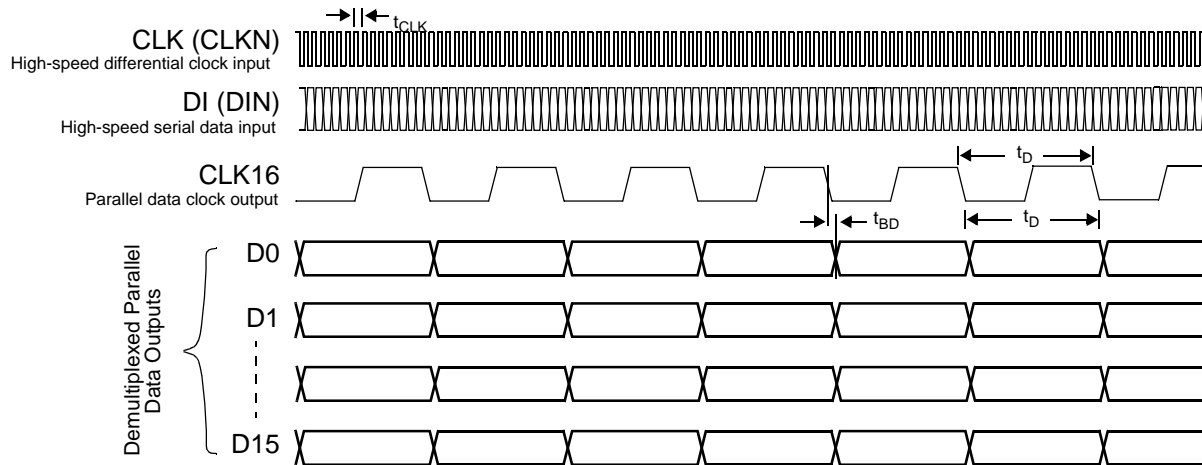

Table 2: VSC8062 AC Characteristics

Parameter	Description	Min	Typ	Max	Units	Conditions
$t_{CLK}$	Clock period <sup>(1)</sup>	400			ps	
$t_D$	BYTE CLK16 period ( $t_{CLK} \times 16$ )	6.4			ns	
$t_{DSU}$	CLK16 falling edge output to valid data	1.0		3.0	ns	
$t_{DH}$	Phase Margin = $\left(1 - \frac{t_{SU} + t_H}{t_{CLK}}\right) \times 360^\circ$ Serial data phase timing margin with respect to high-speed clock <sup>(2)</sup>	180 <sup>(3)</sup>			degrees	

NOTES: (1) If  $t_{CLK}$  changes, all remaining parameters change as indicated by the equations.

(2)  $t_{SU}$  and  $t_H$  are setup and hold times of the serial data input register.

(3) At  $t_{CLK} = 400ps$ .

## DC Characteristics

**Table 3: ECL Inputs and Outputs**
*(Over recommended operating conditions with internal  $V_{REF}$ ,  $V_{CC} = GND$ , output load =  $50\Omega$  to  $-2.0V$ ).*

Parameter	Description	Min	Typ	Max	Units	Conditions
$V_{OH}$	Output HIGH voltage	-1100		-700	mV	$V_{IN} = V_{IH} (max)$ or $V_{IL} (min)$
$V_{OL}$	Output LOW voltage	$V_{TT}$		-1750	mV	$V_{IN} = V_{IH} (max)$ or $V_{IL} (min)$
$V_{IH}$	Input HIGH voltage	-1040		-600	mV	Guaranteed HIGH signal for all inputs
$V_{IL}$	Input LOW voltage	$V_{TT}$		-1600	mV	Guaranteed LOW signal for all inputs
$\Delta V_{ECL\_OUT}$	Output voltage swing	0.850			V	Output load $50\Omega$ to $V_{TT}$
$\Delta V_{ECL\_IN}$	Input voltage swing	0.600	0.800	1.2	V	AC-coupled

*Note: Differential ECL output pins must be terminated identically.*
**Table 4: Power Dissipation**
*(Over recommended operating conditions,  $V_{CC} = GND$ , outputs open circuit)*

Parameter	Description		Min	Typ	Max	Units	Conditions
$I_{EE}$	Power supply current from $V_{EE}$	VSC8061			260	mV	
		VSC8062			220	mV	
$I_{TT}$	Power supply current from $V_{TT}$	VSC8061			260	mV	
		VSC8062			230	mV	
$P_D$	Power dissipation	VSC8061			2.0	W	
		VSC8062			1.7	W	

**Table 5: High-Speed Input and Output Specifications**
*(Over recommended operating conditions,  $V_{CC} = GND$ , output load =  $50\Omega$  to  $-2.0V$ )*

Parameter	Description	Min	Typ	Max	Units	Conditions	
$\Delta V_{HSOUT}$	Output voltage swing	0.7	0.9		V	Output load, $50\Omega$ to $-2.0V$	
$\Delta V_{HSIN}$	Input voltage swing	See Table 6					AC-coupled
$t_R, t_F$	Input voltage rise and fall time (high-speed)		0.2	1.5	ns	Same for all data rates; no worse than sine wave at max speed	

*NOTES: (1) Built-in references generator, the high-speed inputs are designed for AC-coupling.*
*(2) If a high-speed input is driven single-ended, a capacitor should be connected between the unused high-speed or complement input and  $V_{TT}$  (see Figures 7 and 8).*

**Data Sheet**

**VSC8061/VSC8062**

2.5Gb/s 16-Bit  
Multiplexer/Demultiplexer Chipset

**Absolute Maximum Ratings<sup>(1)</sup>**

Power Supply Voltage ( $V_{TT}$ ) .....	-3.0V to 0.5V
Power Supply Voltage ( $V_{EE}$ ) .....	$V_{TT} + 0.7V$ to -7.0V
Input Voltage Applied <sup>(2)</sup> ( $V_{ECLIN}$ ) .....	-2.5V to 0.5V
High-Speed Input Voltage Applied <sup>(2)</sup> ( $V_{HSIN}$ ) .....	$V_{EE}-0.7V$ to $V_{CC}+0.7V$
Output Current, $I_{OUT}$ (DC, output HI) .....	-50mA
Case Temperature Under Bias ( $T_C$ ).....	-55°C to 125°C
Storage Temperature ( $T_{STG}$ ) .....	-65°C to 150°C

NOTES: (1) Caution: Stresses listed under "Absolute Maximum Ratings" may be applied to devices one at a time without causing permanent damage. Functionality at or exceeding the values listed is not implied. Exposure to these values for extended periods may affect device reliability.

(2)  $V_{TT}$  must be applied before the magnitude of any input signal voltage ( $|V_{IN}|$ ,  $|V_{HSIN}|$ ) can be greater than  $|V_{TT} - 0.5V|$ .

**Recommended Operating Conditions**

Power Supply Voltage ( $V_{TT}$ ) .....	-2.0V $\pm$ 5 %
Power Supply Voltage ( $V_{EE}$ ) .....	-5.2V $\pm$ 5 %
Operating Temperature Range <sup>(1)</sup> (T).....	(Commercial) 0°C to +70°C, (Industrial) -40°C to +85°C

NOTE: (1) Lower limit of specification is ambient temperature and upper limit is case temperature.

**ESD Ratings**

For performance considerations, minimum ESD protection is provided for the high-speed input pins. Therefore, proper procedures should be used when handling these products. The VSC8061/8062 are rated to the following ESD voltages based on the human body model:

1. All high-speed input pins are rated at or above 500V.
2. All other pins are rated at or above 2000V.

The above ratings apply to both "F" and "QH" packages.



## Coupling for Inputs

Figure 7: AC-Coupling for DCLK, DCLKN Inputs

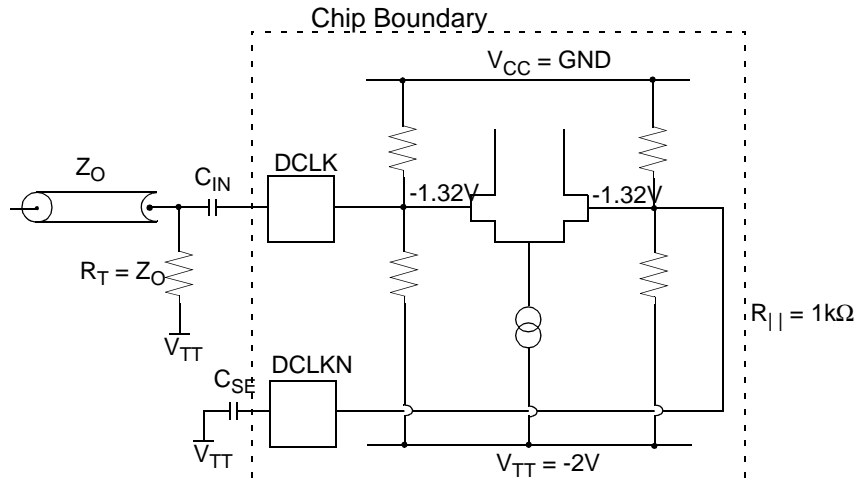

$C_{IN}$  typ = 0.1 $\mu$ F  
 $C_{SE}$  typ = 0.1 $\mu$ F for single-ended applications  
 (Capacitor values are selected for DCLK = 155Mb/s.)

### DCLK, DCLKN Inputs

Internal biasing will position the reference voltage of approximately -1.32V on both the true and complementary inputs. This input can either be DC-coupled or AC-coupled; it can also be driven single-ended or differentially. Figure 7 shows the configuration for a single-ended, AC-coupling operation. In the case of direct coupling and single-ended input, it is recommended that a stable  $V_{REF}$  for ECL levels be used for the complementary input.

### High-Speed Clock and Serial Data Inputs

It is recommended that all high-speed clock and serial data inputs (CLK/CLKN for the VSC8061; DI/DIN and CLK/CLKN for the VSC8062) be AC-coupled. Figure 8 shows the configuration for a single-ended AC-coupling operation.

In most situations, these inputs will have high transition density and little DC offset. However, in cases where this does not hold, direct DC connection is possible. The following is to assist in this application.

All serial data and clock inputs have the same circuit topology, as shown in Figure 8. The reference voltage is created by a resistor divider as shown. If the input signal is driven differentially and DC-coupled to the part, the mid-point of the input signal swing should be centered about this reference voltage and not exceed the maximum allowable amplitude. For single-ended, DC-coupling operations, it is recommended the user provide an external reference voltage which has better temperature and power supply noise rejection than the on-chip resistor divider. The external reference should have a nominal value as indicated in the table and can be connected to either side of the differential gate.



## Data Sheet

# VSC8061/VSC8062

2.5Gb/s 16-Bit  
Multiplexer/Demultiplexer Chipset

**Table 6: High-Speed Clock and Serial Data Inputs**

Product	Input	Reference	Min (p-p)	Max (p-p)
VSC8061	DCLK, DCLKN	-1.32V	600mV	1.2V
VSC8061	CLK, CLKN	-3.5V	600mV	1.2V
VSC8062	DI, DIN	-3.5V	250mV	1.2V
VSC8062	CLK, CLKN	-3.5V	250mV	1.2V

**Figure 8: High-Speed Clock and Serial Data Inputs**

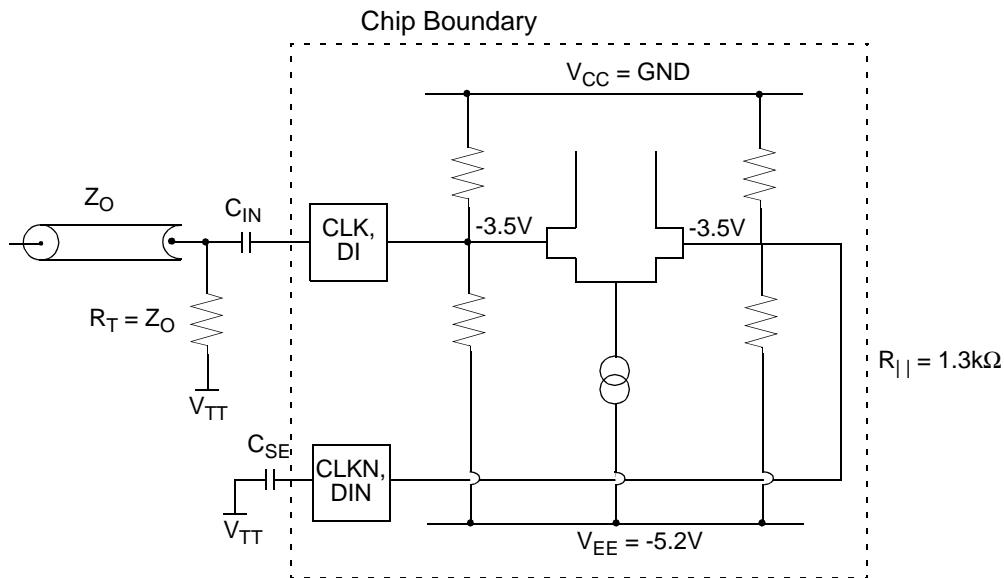

$C_{IN}$  typ = 100pF  
 $C_{SE}$  typ = 100pF for single-ended applications  
 (Capacitor values are selected for DI = 2.5Gb/s.)

### Package Pin Descriptions

Figure 9: VSC8061/8062 F (52-Pin LDCC) Pin Diagrams

Heat Sink Up  
Top View

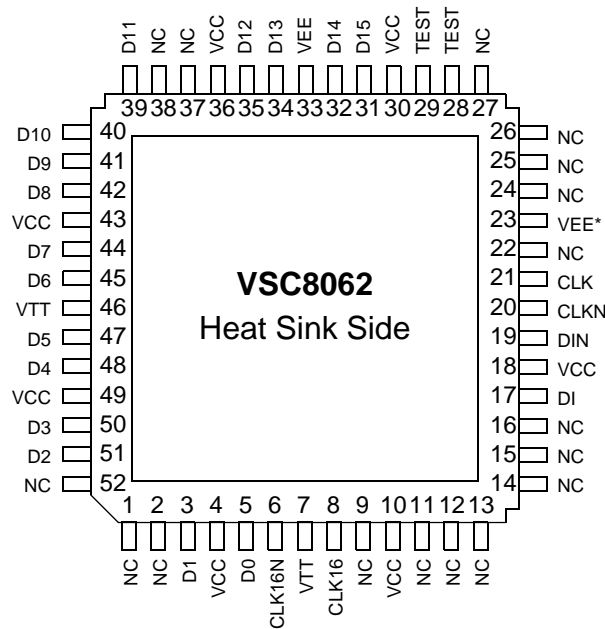
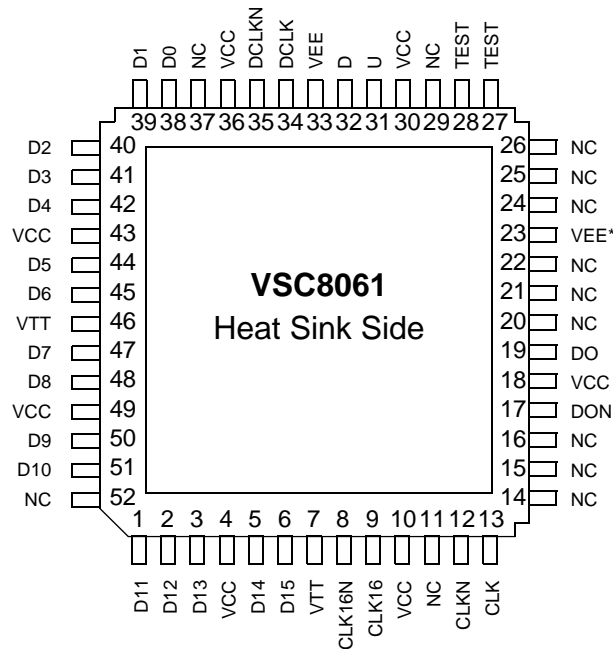

\*Heat sink is electrically connected to pin 23 and should be biased to  $V_{EE}$ .

Figure 10: VSC8061/8062 QH (52-Pin PQFP) Pin Diagrams

Heat Spreader Up  
Top View

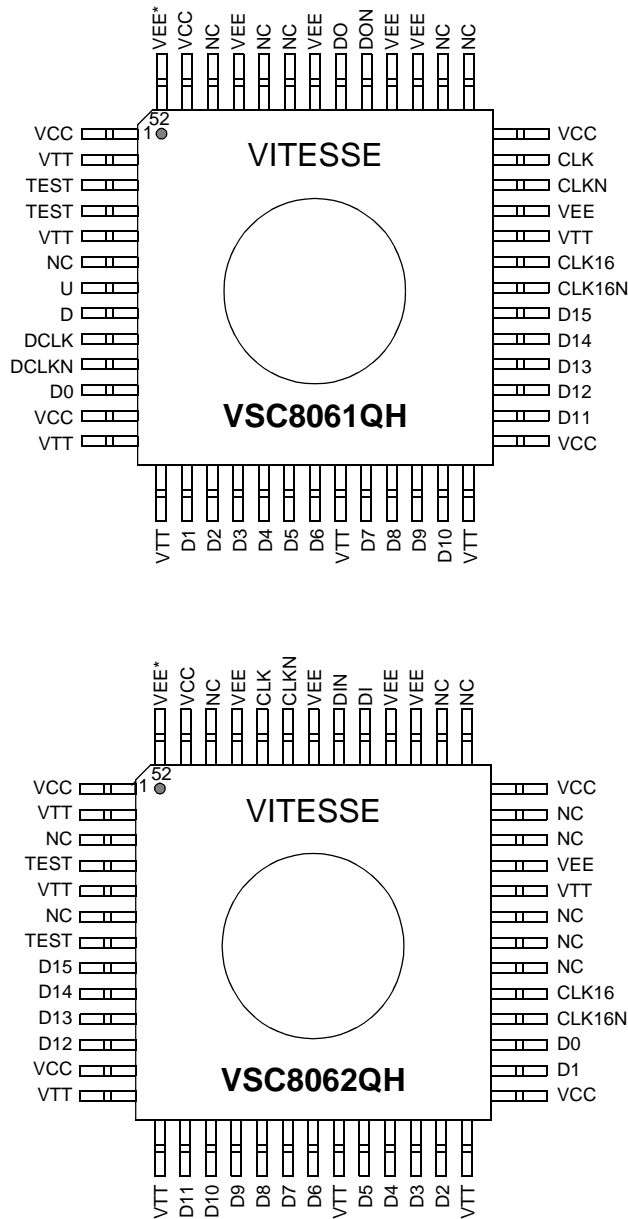

\*Heat spreader is electrically connected to pin 52 and should be biased to  $V_{EE}$ .

**Table 7: VSC8061 Pin Identifications**

<i>Pin Number QH Package</i>	<i>Pin number F Package</i>	<i>Signal Name</i>	<i>I/O</i>	<i>Level</i>	<i>Description</i>
38	13	CLK	I	HS	High-speed clock true <sup>(1)</sup>
37	12	CLKN	I	HS	High-speed clock, complement <sup>(1)</sup>
9	34	DCLK	I	ECL	Data clock true <sup>(1)</sup>
10	35	DCLKN	I	ECL	Data Clock complement <sup>(1)</sup>
34	9	CLK16	O	ECL	Clock divide-by-16, true
33	8	CLK16N	O	ECL	Clock divide-by-16, complement
11, 15-20, 22-25, 28-32	1-3, 5, 6, 8-42, 44, 45, 47, 48, 50, 51	D[0:15]	I	ECL	Parallel data inputs
45	19	DO	O	HS	Serial data output, true
44	17	DON	O	HS	Serial data output, complement
7	31	U	O	ECL	Phase detector output - up frequency
8	32	D	O	ECL	Phase detector output - down frequency
1, 12, 27, 39, 51	4, 10, 18, 30, 36, 43, 49	V <sub>CC</sub>	Pwr		Most positive power supply
2, 5, 13, 14, 21, 26, 35	7,46	V <sub>TT</sub>	Pwr		DCFL negative power supply
36, 42, 43, 46, 49	33	V <sub>EE</sub>	Pwr		SCFL negative power supply
6, 40, 41, 47, 48, 50	11, 14-16, 20-22, 24-26, 29, 37, 52	NC			Do not connect, leave open
3, 4	27, 28	Test			Test inputs. Used in factory for testing, connect to VTT through a resistor
52	23	V <sub>EE</sub>	Pwr		Heat sink bias, connect to V <sub>EE</sub>

NOTE: (1) Can be used single-ended.

# Data Sheet

## VSC8061/VSC8062

2.5Gb/s 16-Bit  
Multiplexer/Demultiplexer Chipset

**Table 8: VSC8062 Pin Identifications**

Pin Number QH Package	Pin Number F Package	Signal Name	I/O	Level	Description
48	21	CLK	I	HS	High-speed clock, true <sup>(1)</sup>
47	20	CLKN	I	HS	High-speed clock, complement <sup>(1)</sup>
44	17	DI	I	HS	Serial data input, true <sup>(1)</sup>
45	19	DIN	I	HS	Serial data input, complement <sup>(1)</sup>
31	8	CLK16	O	ECL	Parallel data clock (high-speed clock divide-by-16), true
30	6	CLK16N	O	ECL	Parallel data clock (high-speed clock divide-by-16), complement
8-11, 15-20, 22-25, 28, 29	3, 5, 31, 32, 34, 35, 39-42, 44, 45, 47, 48, 50, 51	D[0:15]	O	ECL	Parallel data outputs
1, 12, 27, 39, 51	4, 10, 18, 30, 36, 43, 49	V <sub>CC</sub>	Pwr		Most positive power supply
2, 5, 13, 14, 21, 26, 35	7, 46	V <sub>TT</sub>	Pwr		DCFL negative power supply
36, 42, 43, 46, 49	33	V <sub>EE</sub>	Pwr		SCFL negative power supply
3, 6, 32-34, 37, 38, 40, 41, 50	1, 2, 9, 11-16, 22, 24-27, 37, 38, 52	NC			Do not connect, leave open
4, 7	28, 29	Test	Pwr		Test inputs. Used in factory for testing, connect to V <sub>TT</sub> through a resistor
52	23	V <sub>EE</sub> *	Pwr		Heat sink bias, connect to V <sub>EE</sub>

NOTE: (1) Can be used single-ended.

## Package Information

### 52-Pin Ceramic LDCC (F) Package

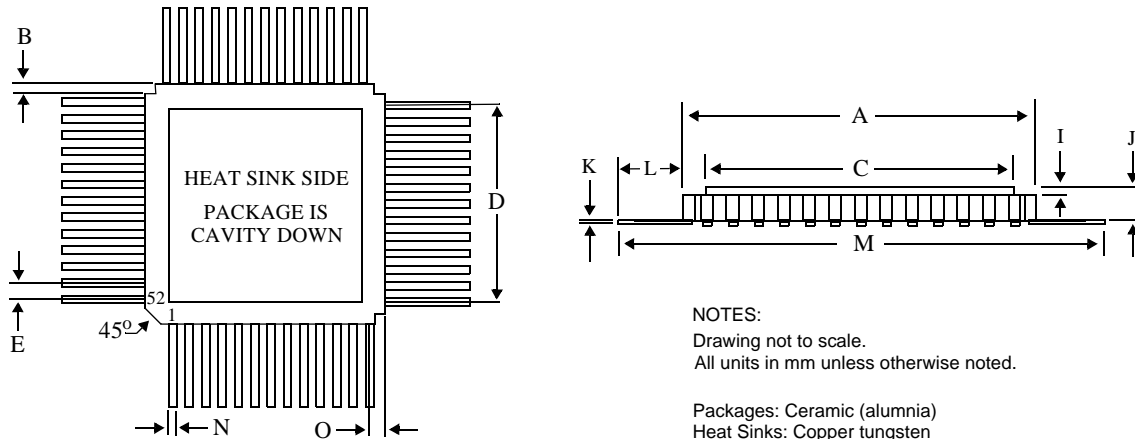

Item	mm (Min/Max)	in (Min/Max)	Item	mm (Min/Max)	in (Min/Max)
A	18.54/19.56	0.730/0.770	I	0.41/0.61	0.016/0.024
B	1.02/1.52	0.040/0.060	J	2.03/2.79	0.080/0.110
C <sup>(1)</sup>	15.49/16.51	0.610/0.650	K <sup>(1)</sup>	0.09/0.24	0.003/0.009
D <sup>(1)</sup>	15.24 TYP	0.600 TYP	L	4.57/5.34	0.180/0.210
E	1.27 TYP	0.050 TYP	M	27.69/30.22	1.090/1.190
			N	0.36/0.56	0.014/0.022
			O	1.75/1.90	0.069/0.075

NOTE: (1) At package body.

## Data Sheet

## VSC8061/VSC8062

2.5Gb/s 16-Bit  
Multiplexer/Demultiplexer Chipset

52 Pin PQFP (QH) Package

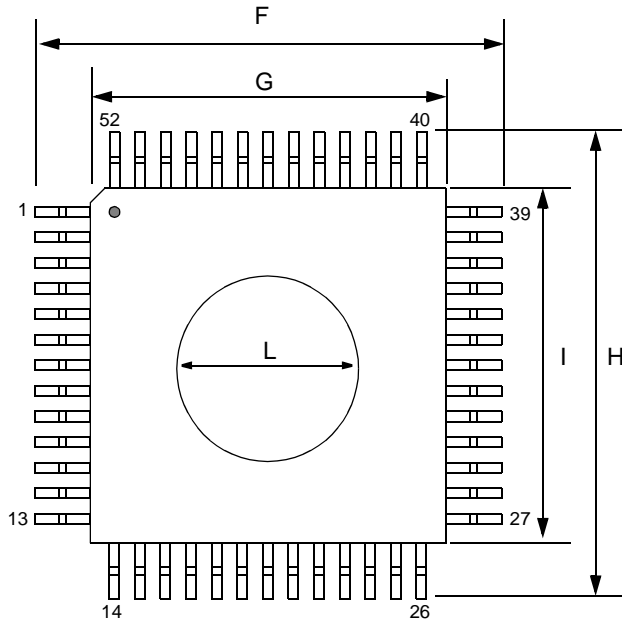

Item	mm	Tol.
A	2.35	MAX
D	2.00	+ .10 / - .05
E	0.35	±.05
F	17.20	±.25
G	14.00	±.10
H	17.20	±.25
I	14.00	±.10
J	0.88	+ .15 / - .10
J1	0.80	+ .15 / - .10
K	1.00	BASIC
L	5.84	±.50 DIA.

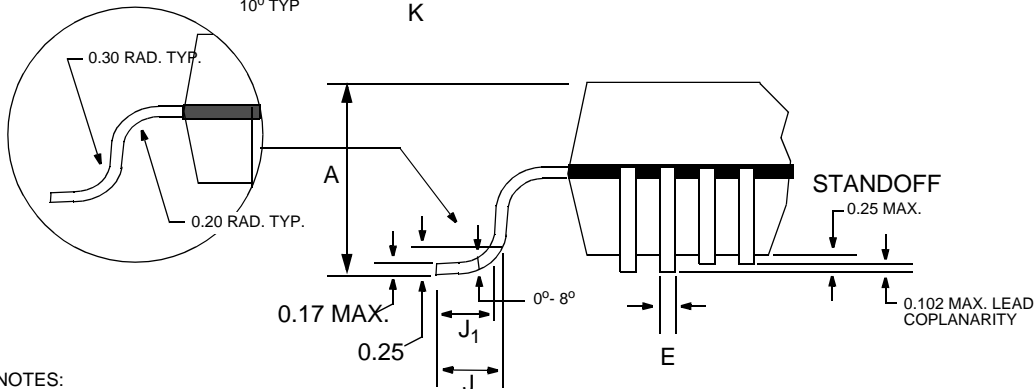
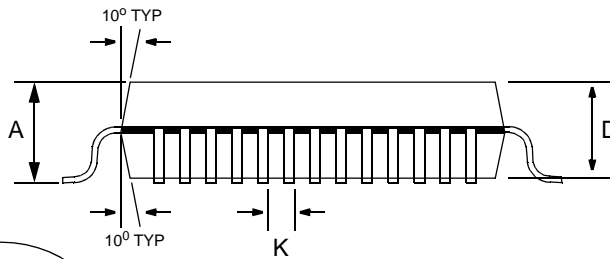

NOTES:  
 Drawing not to scale.  
 Heat spreader up.  
 All units in mm unless otherwise noted.



## Thermal Considerations

The VSC8061 and VSC8062 are available in ceramic LDCC and thermally enhanced plastic quad flat-packs. These packages have been enhanced to improve thermal dissipation through low thermal resistance paths from the die to the exposed surface of the heat spreader. The thermal resistance of the two packages is shown in the following table

**Table 9: Thermal Resistance**

Symbol	Description	F Pack	QH Pack	Units
$\theta_{JC}$	Thermal resistance from junction-to -case.	1.3	2.1	°C/W
$\theta_{CA}$	Thermal resistance from case-to-ambient still air including conduction through the leads.	18.5	30.0	°C/W

### Thermal Resistance with Airflow

Shown in Table 10 is the thermal resistance with airflow. This thermal resistance value reflects all the thermal paths including through the leads in an environment where the leads are exposed. The temperature difference between the ambient airflow temperature and the case temperature should be the worst case power of the device multiplied by the thermal resistance.

**Table 10: Thermal Resistance with Airflow**

Airflow	$\theta_{CA}$ for F Package	$\theta_{CA}$ for QH Package	Units
100 lfpm	15.9	24	°C/W
200 lfpm	14.9	21	°C/W
300 lfpm	14.2	19	°C/W
500 lfpm	13.3	15	°C/W

### Thermal Resistance with Heat Sink

The determination of appropriate heat sink to use is as shown below, using the VSC8061 in QH package as an example.

**Figure 11: VSC8061 in QH Package**

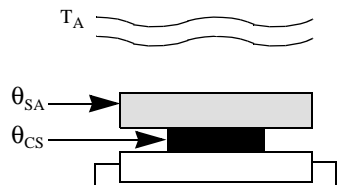

## Data Sheet

# VSC8061/VSC8062

2.5Gb/s 16-Bit  
Multiplexer/Demultiplexer Chipset

The worst-case temperature rise from case to ambient is given by the equation:

$$\Delta T = P_{(MAX)}(\theta_{SA} + \theta_{CS})$$

where:

- $\theta_{SA}$  = Theta sink-to-ambient
- $\theta_{CS}$  = Theta case-to-sink
- $T_{A(MAX)}$  = Air temperature, user supplied (typically +55° C)
- $T_{C(MAX)}$  = Case temperature (+85°C for Industrial range)
- $\Delta T$  =  $T_C - T_A$
- $P_{(MAX)}$  = Power (2.0 W for VSC8061)

$$\therefore P = \frac{\Delta T}{\Sigma \theta} = \frac{T_C - T_A}{\theta_{SA} + \theta_{CS}}$$

$$\theta_{SA} = \frac{\Delta T}{P} - \theta_{CS}$$

If  $T_A = 55^\circ \text{C}$  and  $\theta_{CS}$  (user supplied) is typically  $0.6^\circ \text{C/W}$ ,

$$\theta_{SA} = \frac{(85 - 55)^\circ \text{C}}{2 \text{ W}} - 0.6^\circ \text{C/W}$$

$$\theta_{SA} = 14.4^\circ \text{C/W}$$

Therefore, to maintain the proper case and junction temperature, a heat sink with a  $\theta_{SA}$  of  $14.4^\circ \text{C/W}$  or less must be selected at the appropriate air flow.

NOTE: The heat spreader is tied to  $V_{EE}$  in both the VSC8061 and VSC8062.

**Figure 12: Data Eye From Serial Output of VSC8061 in QH Package (D0/D0N)**

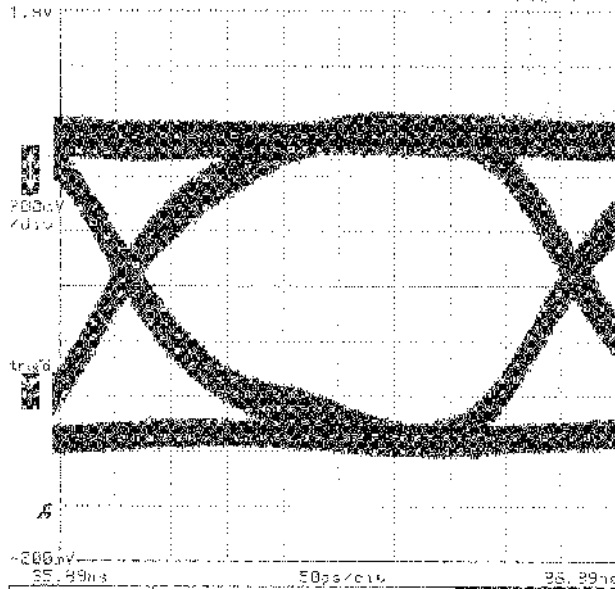

Amplitude: 200 mV/div  
Time Scale: 50 ps/div  
Data Rate: 2.5 Gb/s

**Figure 13: Measurement Setup**

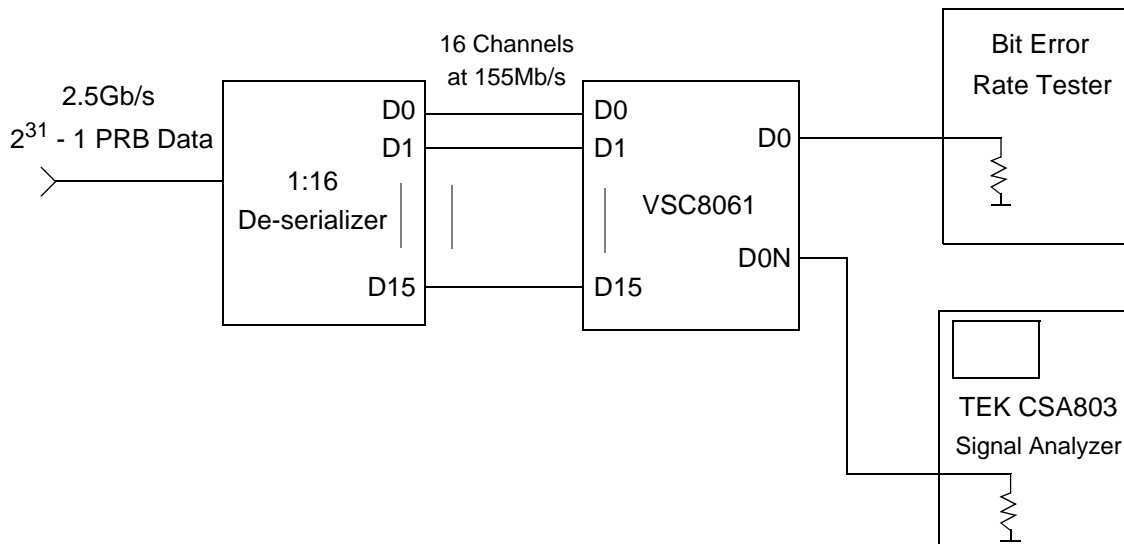

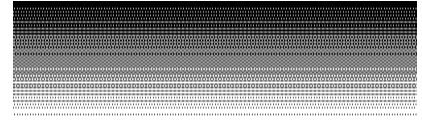
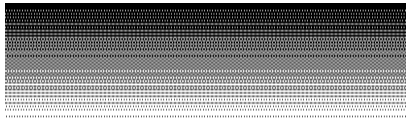

**Data Sheet**

**VSC8061/VSC8062**

2.5Gb/s 16-Bit  
Multiplexer/Demultiplexer Chipset

**Ordering Information**

The order number for this product is formed by a combination of the device number, package type, and the operating temperature range.

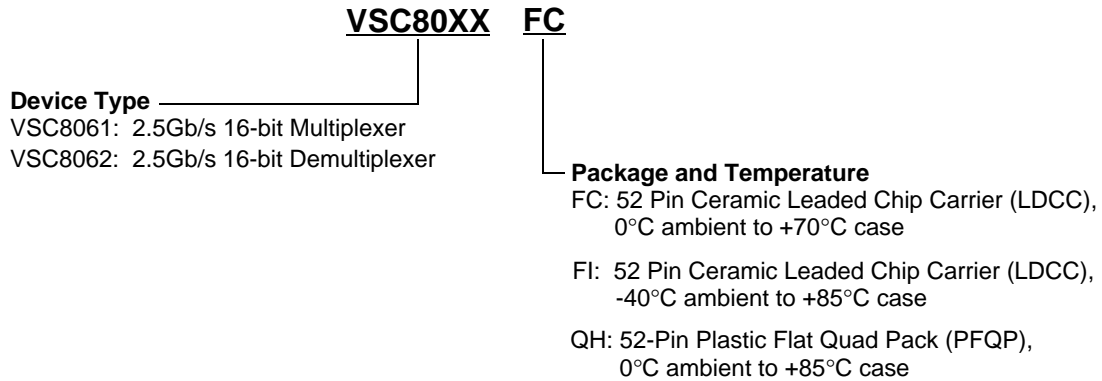

**Notice**

Vitesse Semiconductor Corporation ("Vitesse") provides this document for informational purposes only. All information in this document, including descriptions of features, functions, performance, technical specifications and availability, is subject to change without notice at any time. Nothing contained in this document shall be construed as extending any warranty or promise, express or implied, that any Vitesse product will be available as described or will be suitable for or will accomplish any particular task.

Vitesse products are not intended for use in life support appliances, devices or systems. Use of a Vitesse product in such applications without written consent is prohibited.

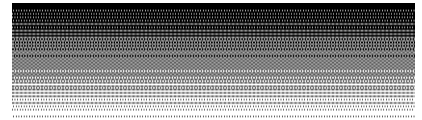

2.5Gb/s 16-Bit  
Multiplexer/Demultiplexer Chipset

**Data Sheet**  
**VSC8061/VSC8062**

