

## Preliminary Data Sheet

### VSC8163

OC-48 16:1 SONET/SDH  
MUX with Clock Generator

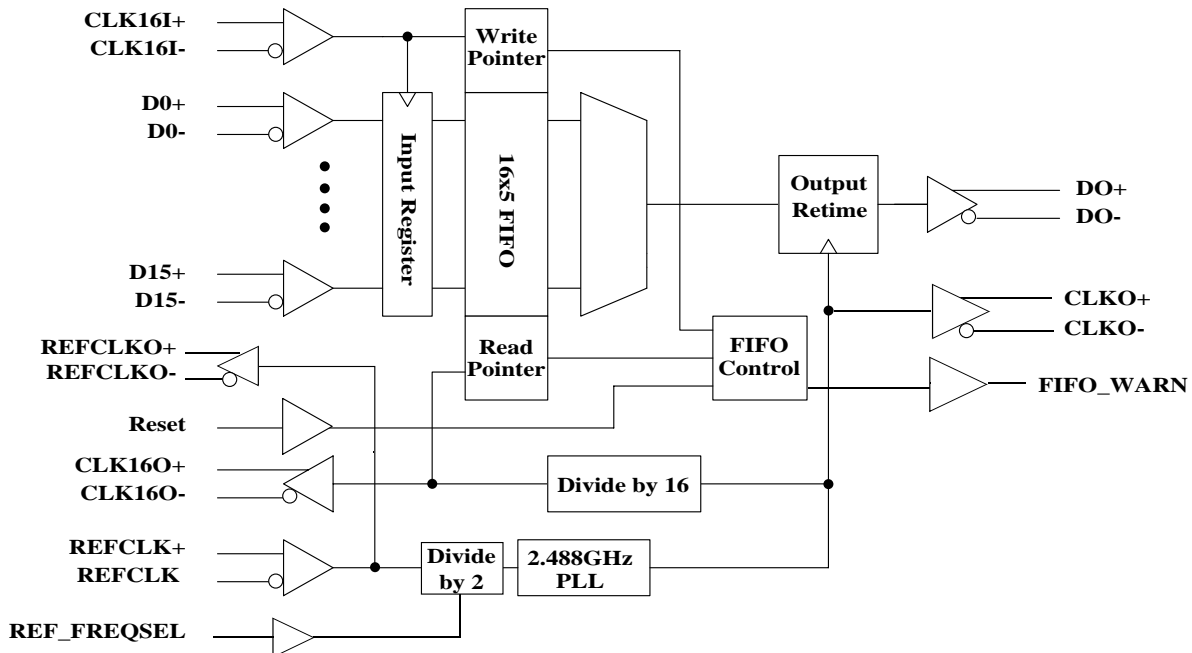
### Features

- 2.488Gb/s 16:1 Multiplexer
- Targeted for SONET OC-48 / SDH STM-16 Applications
- Differential LVPECL Low-Speed Interface
- On-Chip PLL-Based Clock Generator
- 128 Pin, 14x20mm PQFP Package
- Single +3.3V Supply

### General Description

The VSC8163 is a 16:1 multiplexer with integrated clock generator for use in SONET/SDH systems operating at a 2.48832Gb/s data rate. The internal clock generator uses a Phase-Locked Loop (PLL) to multiply either a 77.76MHz or 155.52MHz reference clock in order to provide the 2.48832GHz clock for internal logic and output retiming. The 16-bit parallel interface incorporates an on-board FIFO, eliminating loop timing design issues by providing a flexible parallel timing architecture. The device operates using a +3.3V power supply, and is packaged in a thermally-enhanced plastic package. The thermal performance of the 128PQFP allows the use of the VSC8163 without a heat sink under most thermal conditions.

### VSC8163 Block Diagram



## Functional Description

### Low-Speed Interface

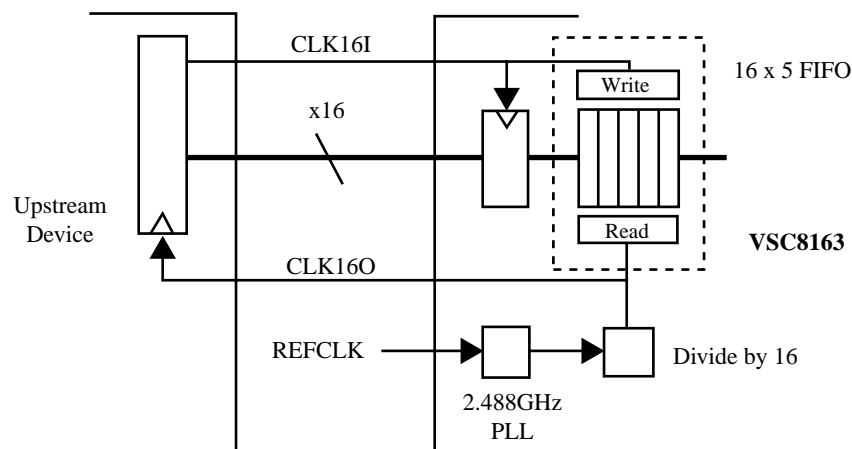
The Upstream Device should use the CLK16O as the timing source for its final output latch (see Figure 1). The Upstream Device should then generate a CLK16I phase aligned with the data. The VSC8163 will latch D[15:0] $\pm$  on the rising edge of CLK16I+. The data must meet setup and hold times with respect to CLK16I (see Table 2). In addition to the CLK16O clock output, there also exists a utility REFCLKO output signal, which is a clock with the same rate as that presented at the REFCLK input.

A FIFO exists within the VSC8163 to eliminate difficult system loop timing issues. Once the PLL has locked to the reference clock, RESET must be held low for a minimum of five CLK16 cycles ( $> 32\text{ns}$ ) to initialize the FIFO, then RESET should be set high and held constant for continuous FIFO operation. For the transparent mode of operation (no FIFO), simply hold RESET at a constant low state (see Figure 2).

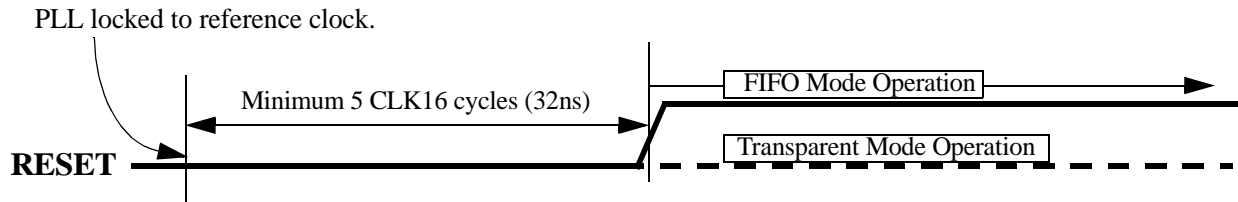
The use of a FIFO permits the system designer to tolerate an arbitrary amount of delay between CLK16O and CLK16I. Once RESET is asserted and the FIFO initialized, the delay between CLK16O and CLK16I can decrease or increase up to one period of the low-speed clock (6.4ns). Should this delay drift exceed one period, the write pointer and the read pointer could point to the same word in the FIFO, resulting in a loss of transmitted data (a FIFO overflow). In the event of a FIFO overflow, an active low FIFO\_WARN signal is asserted (for a minimum of 5 CLK16I cycles) which can be used to initiate a reset signal from an external controller.

The CLK16O $\pm$  output driver is a LVPECL output driver designed to drive a 50 $\Omega$  transmission line. The transmission line can be DC terminated with a split-end termination scheme (see Figure 3), or DC terminated by 50 $\Omega$  to  $V_{CC}-2\text{V}$  on each line (see Figure 4). At any time, the equivalent split-end termination technique can be substituted for the traditional 50 $\Omega$  to  $V_{CC}-2\text{V}$  on each line. AC-coupling can be achieved by a number of methods. Figure 5 illustrates an example AC-coupling method for the occasion when the downstream device provides the bias point for AC-coupling. If the downstream device were to have internal termination, the line-to-line 100 $\Omega$  resistor may not be necessary.

**Figure 1: Low-Speed Systems Interface**

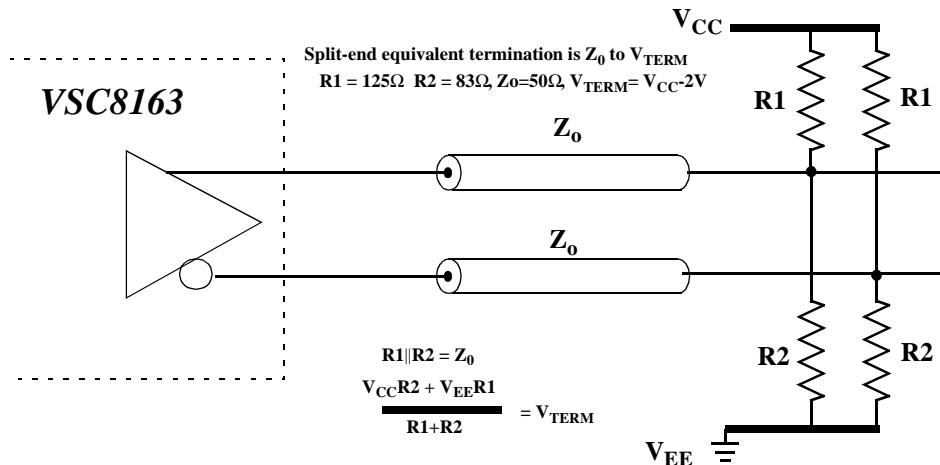


**Figure 2: Enabling FIFO Operation**



Holding RESET “low” for a minimum of five CLK16 cycles, then setting “high” enables FIFO operation. Holding RESET constantly “low” bypasses the FIFO for transparent mode operation.

**Figure 3: Split-End DC Termination of CLK16O+/-, REFCLKO+/-**



**Figure 4: Traditional DC Termination of CLK16O+/-, REFCLKO+/-**

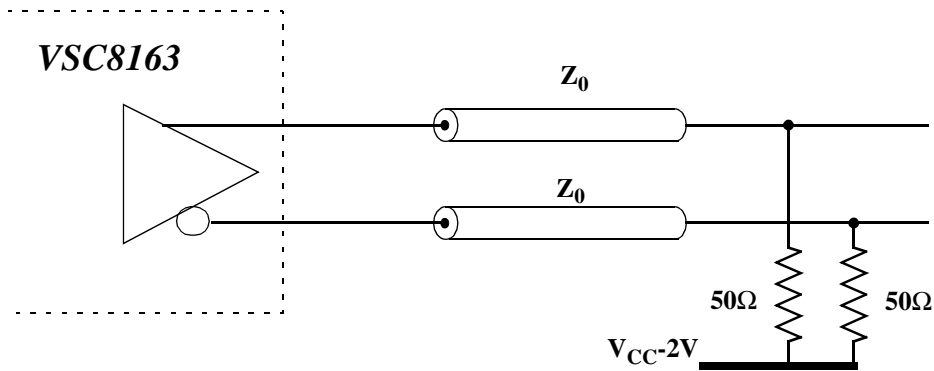
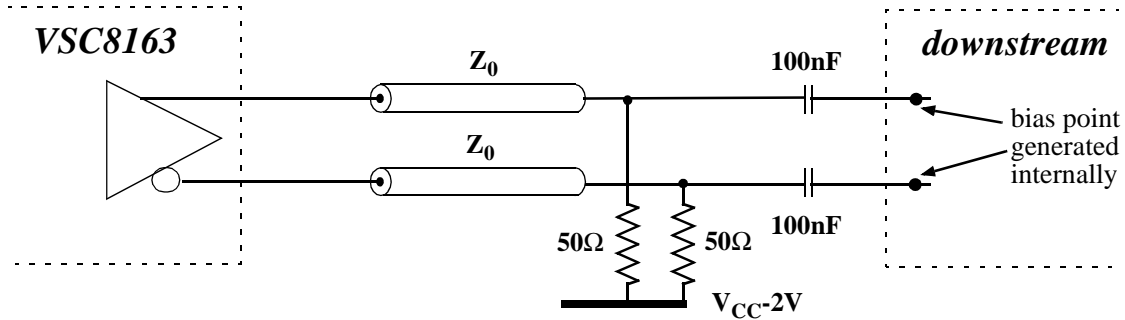


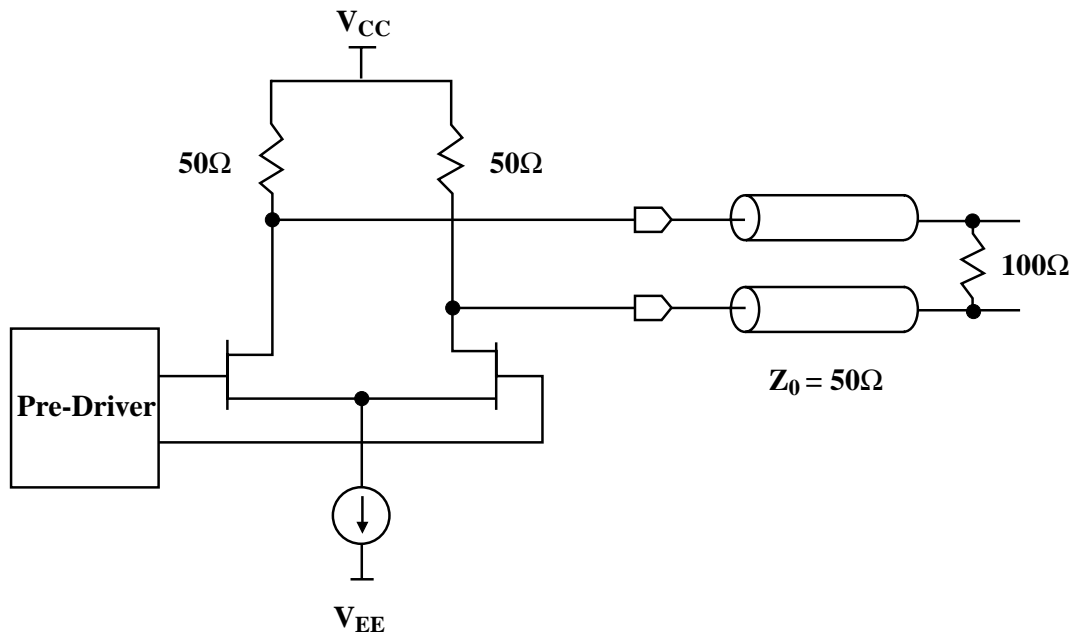
Figure 5: AC Termination of CLK16O+/-, REFCLKO+/-



### High-Speed Data and Clock Output

The high-speed data and clock output drivers consist of a differential pair designed to drive a 50Ω transmission line. The transmission line should be terminated with a 100Ω resistor at the load between true and complement outputs (see Figure 6). Connection to a termination voltage is not required. The output driver is back terminated to 50Ω on-chip, providing a snubbing of any reflections. If used single-ended, the high-speed output driver must still be terminated differentially at the load with a 100Ω resistor between true and complement outputs. The high-speed clock output can be powered down for additional power savings. To power down the high-speed clock, tie the associated pins to  $V_{CC}$  (see Table 3, Package Pin Descriptions, pins 5,6,7).

Figure 6: High-Speed Output Termination



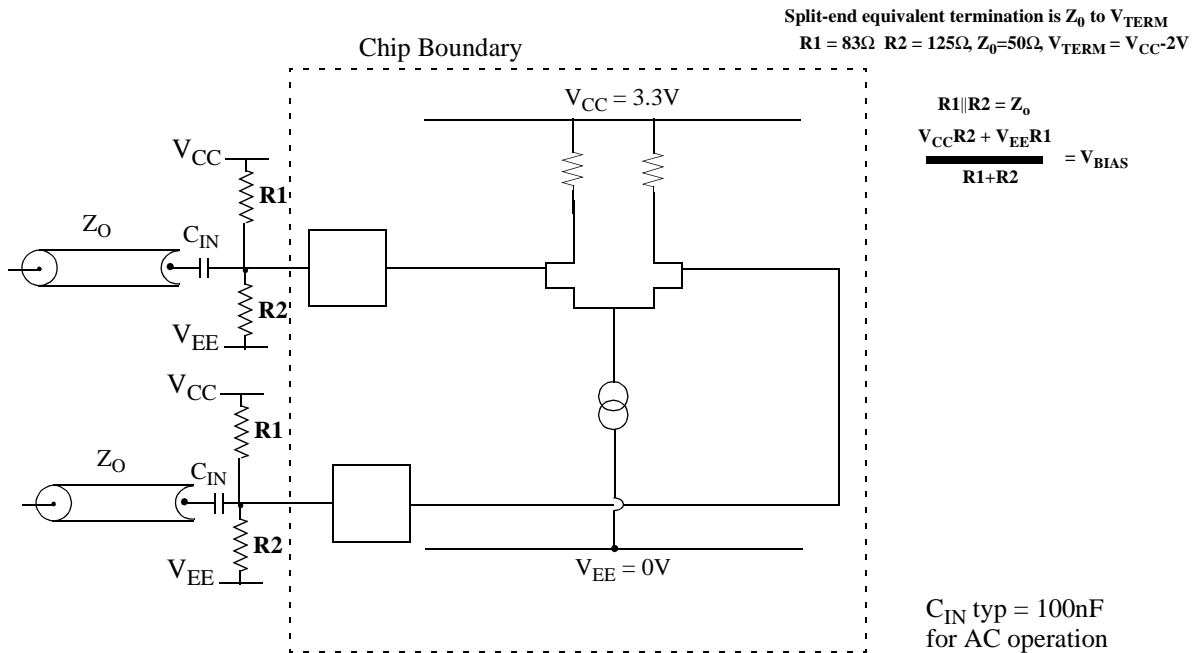
**Clock Generator**

An on-chip PLL generates the 2.48832GHz transmit clock from the externally provided REFCLK input. The on-chip PLL uses a low phase noise reactance-based Voltage Controlled Oscillator (VCO) with an on-chip loop filter. The loop bandwidth of the PLL is within the SONET specified limit of 2MHz.

The customer can select to provide either a 77.76MHz reference (recommended), or the 2x of that reference, 155.52MHz. REF\_FREQSEL is used to select the desired reference frequency. REF\_FREQSEL = "0" designates REFCLK input as 77.76MHz, REF\_FREQSEL = "1" designates REFCLK input as 155.52MHz.

The REFCLK should be of high quality since noise on the REFCLK below the loop band width of the PLL will pass through the PLL and appear as jitter on the output. Preconditioning of the REFCLK signal with a VCXO may be required to avoid passing REFCLK noise with greater than 2ps of RMS jitter to the output. The VSC8163 will output the REFCLK noise in addition to the intrinsic jitter from the VSC8163 itself during such conditions.

**Figure 7: AC Termination of Low-Speed LVPECL REFCLK, D[15:0] Inputs**



**Low-Speed Inputs**

The incoming low-speed data and reference clock input are received by LVPECL inputs D[15:0] and REFCLK. Off-chip termination of these inputs is required. For AC-coupling, a bias voltage suitable for AC-coupling needs to be provided (see Figure 7 for external biasing resistor scheme).

In most situations these inputs will have high transition density and little DC offset. However, in cases where this does not hold, direct DC connection is possible. All serial data inputs have the same circuit topology, as shown in Figure 7. If the input signal is driven differentially and DC-coupled to the part, the mid-point of the

input signal swing should be centered about this common-mode reference voltage ( $V_{\text{CMI}}$ ) and not exceed the maximum allowable amplitude. For single-ended, DC-coupling operations, it is recommended that the user provides an external reference voltage. The external reference should have a nominal value equivalent to the common mode switch point of the DC-coupled signal, and can be connected to either side of the differential gate.

### Power Supplies

This device is specified as a LVPECL device with a single positive 3.3V supply. Should the user desire to use the device in an ECL environment with a negative 3.3V supply, then  $V_{\text{CC}}$  will be ground and  $V_{\text{EE}}$  will be -3.3V. If used with  $V_{\text{EE}}$  tied to -3.3V, the TTL control signals are still referenced to  $V_{\text{EE}}$ .

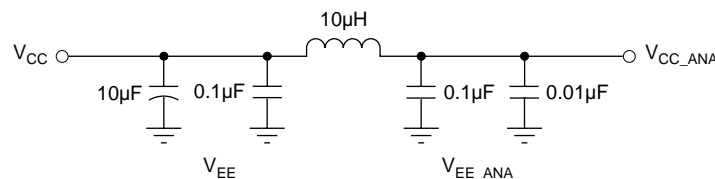
Decoupling of the power supplies is a critical element in maintaining the proper operation of the part. It is recommended that the  $V_{\text{CC}}$  power supply be decoupled using a 0.1 $\mu\text{F}$  and 0.01 $\mu\text{F}$  capacitor placed in parallel on each  $V_{\text{CC}}$  power supply pin as close to the package as possible. If room permits, a 0.001 $\mu\text{F}$  capacitor should also be placed in parallel with the 0.1 $\mu\text{F}$  and 0.01 $\mu\text{F}$  capacitors mentioned above. Recommended capacitors are low inductance ceramic SMT X7R devices. For the 0.1 $\mu\text{F}$  capacitor, a 0603 package should be used. The 0.01 $\mu\text{F}$  and 0.001 $\mu\text{F}$  capacitors can be either 0603 or 0402 packages.

Extra care needs to be taken when decoupling the analog power supply pins ( $V_{\text{CCANA}}$ ). In order to maintain the optimal jitter and loop bandwidth characteristics of the PLL contained in the VSC8163, the analog power supply pins should be filtered from the main power supply with a 10 $\mu\text{H}$  C-L-C pi filter. If preferred, a ferrite bead may be used to provide the isolation. The 0.1 $\mu\text{F}$  and 0.01 $\mu\text{F}$  decoupling capacitors are still required and must be connected to the supply pins between the device and the C-L-C pi filter (or ferrite bead).

For low frequency decoupling, 47 $\mu\text{F}$  tantalum low inductance SMT caps are sprinkled over the board's main +3.3V power supply and placed close to the C-L-C pi filter.

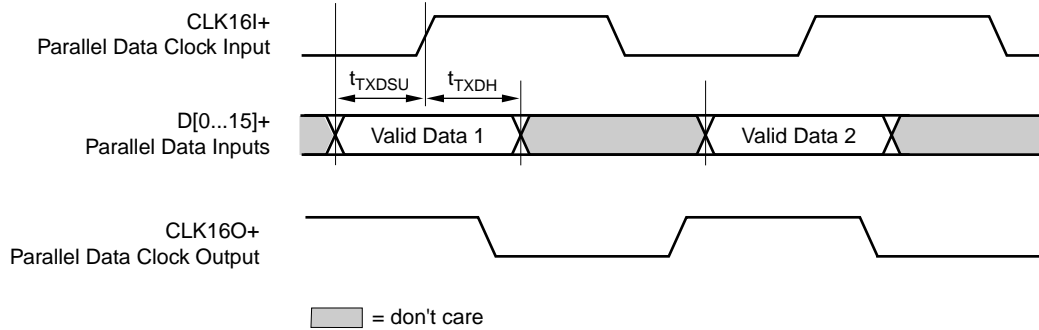
If the device is being used in an ECL environment with a -3.3V supply, then all references to decoupling  $V_{\text{CC}}$  must be changed to  $V_{\text{EE}}$ , and all references to decoupling 3.3V must be changed to -3.3V.

**Figure 8: PLL Power Supply Decoupling Scheme**

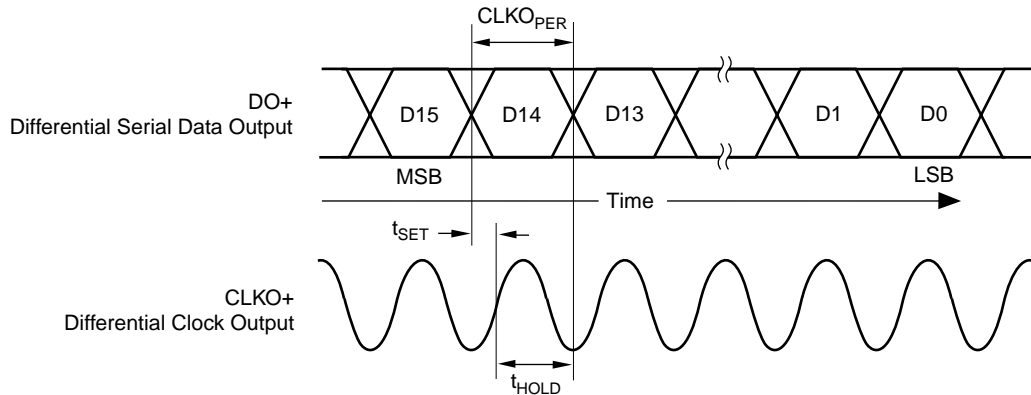


## AC Characteristics

**Figure 9: Parallel Input Data and Clock Timing Waveforms**



**Figure 10: Serial Data and Clock Output Phase Timing Waveforms**



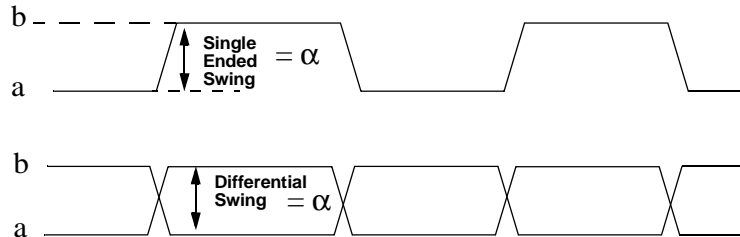
NOTE: Bit 15 (MSB) is received first, Bit 0 (LSB) is received last.

**Table 1: AC Characteristics**

<i>Parameters</i>	<i>Description</i>	<i>Min</i>	<i>Typ</i>	<i>Max</i>	<i>Units</i>	<i>Conditions</i>
$T_{DSU}$	Data setup time to the rising edge of CLK16I+	0.75	—	—	ns	
$T_{DH}$	Data hold time after the rising edge of CLK16+	1.0	—	—	ns	
$T_{DOR}, T_{DOF}$	DO± rise and fall time	—	—	120	ps	20% to 80% into 100Ω load See Figure 6
$t_{CLKR}, t_{CLKF}$	CLK16O± rise and fall times	—	—	250	ps	See Figures 3 and 4
$CLK16O_D$	CLK16O± duty cycle	40	—	60	%	
$CLK16I_D$	CLK16I± duty cycle	30	—	70	%	Assuming 10% distortion of CLKO
$RCK_D$	Reference clock duty cycle	40	—	60	%	
$CLKO_D$	CLKO duty cycle	40	—	60	%	
$CLKO_{PER}$	CLKO period	—	401.9	—	ps	SONET based 77.76MHz or 155.52MHz reference clock
$CLK16O_{PER}$	CLK16O period	—	6.4	—	ns	SONET based 77.76MHz or 155.52MHz reference clock
$t_{SET}$	DO setup time with respect to rising CLKO edge	—	90	—	ps	Inverting CLKO will switch (approx) $t_{SET}$ and $t_{HOLD}$ values.
$t_{HOLD}$	DO hold time with respect to rising CLKO edge	—	310	—	ps	Inverting CLKO will switch (approx) $t_{SET}$ and $t_{HOLD}$ values.
<b><i>Clock Multiplier Performance</i></b>						
$T_{DJ}$	Output data jitter	—	—	4	ps	rms, tested to SONET specification (12kHz to 20MHz) with 2ps rms jitter on REFCLK.
$T_{CJ}$	Output clock jitter	—	—	4	ps	rms, tested to SONET specification (12kHz to 20MHz) with 2ps rms jitter on REFCLK.
Jitter <sub>tol</sub>	Jitter tolerance	—	—	—	—	Exceeds SONET/SDH mask
	Tuning Range	-100		+100	ppm	



**Figure 11: Differential and Single-Ended Input / Output Voltage Measurement**



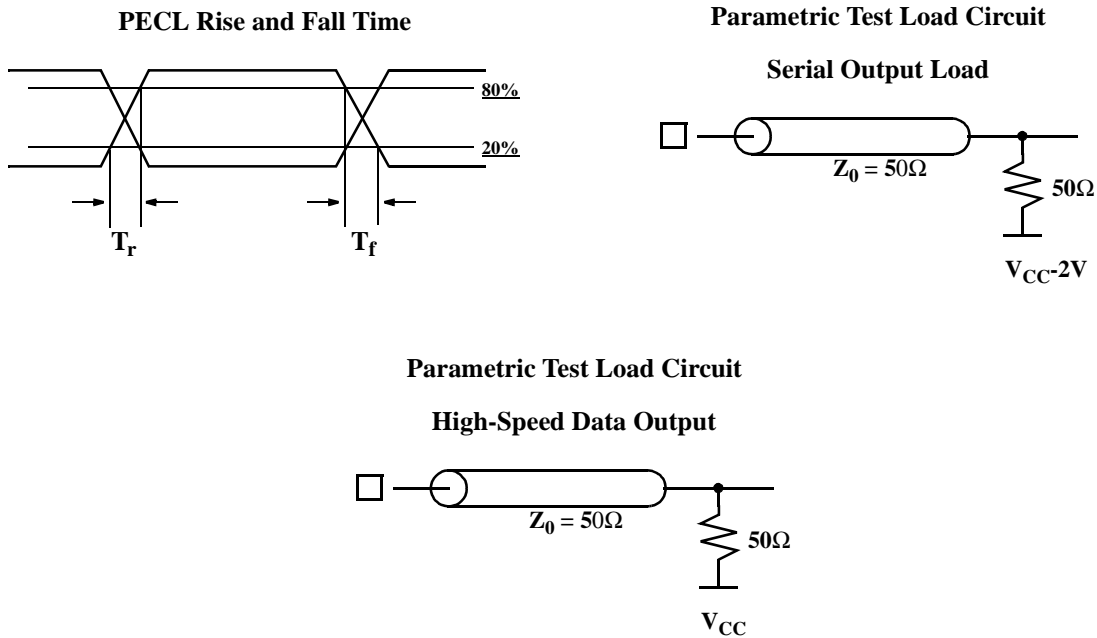
\* Differential swing ( $\alpha$ ) is specified as  $|b - a|$  ( or  $|a - b|$  ), as is the single ended swing.  
 Differential swing is specified as equal in magnitude to single ended swing.

**Table 2: DC Characteristics** (Over recommended operating conditions)

Parameters	Description	Min	Typ	Max	Units	Conditions
$V_{OH(DO)}$	Output HIGH voltage (DO)	$V_{CC} - 0.825$	—	$V_{CC}$	V	See Figure 12
$V_{OL(DO)}$	Output LOW voltage (DO)	$V_{CC} - 1.30$	—	$V_{CC} - 0.50$	V	See Figure 12
$\Delta V_{OD(DO)}$	Data output differential voltage (DO)	550	—	900	mV	100 $\Omega$ termination between $DO_{\pm}$ at load
$\Delta V_{OCLK(CLKO)}$	CLK output differential voltage (CLKO)	500	—	900	mV	100 $\Omega$ termination between $DO_{\pm}$ at load
$V_{CMO}$	Output common-mode voltage	2.10	—	3.00	V	
$R_{DO}$	Back termination impedance	40	—	60	$\Omega$	Guaranteed, not tested
$V_{OH}$	Output HIGH voltage (CLK16O, REFCLKO)	$V_{CC} - 1.020$	—	$V_{CC} - 0.700$	V	See Figure 12
$V_{OL}$	Output LOW voltage (CLK16O, REFCLKO)	$V_{CC} - 2.000$	—	$V_{CC} - 1.620$	V	See Figure 12
$V_{IH}$	Input HIGH voltage (LVPECL)	$V_{CC} - 1.100$	—	$V_{CC} - 0.700$	V	
$V_{IL}$	Input LOW voltage (LVPECL)	$V_{CC} - 2.0$	—	$V_{CC} - 1.540$	V	
$I_{IH}$	Input HIGH current (LVPECL)	—	—	200	$\mu A$	$V_{IN} = V_{IH(max)}$
$I_{IL}$	Input LOW current (LVPECL)	-50	—	—	$\mu A$	$V_{IN} = V_{IL(min)}$
$R_I$	Input resistance (LVPECL)	10k	—	—	$\Omega$	
$\Delta V_I$	Input differential voltage (LVPECL)	200	—	—	mV	
$V_{CMI}$	Input common-mode voltage (LVPECL)	$V_{CC} - 1.5$	—	$V_{CC} - 0.5$	V	
$V_{OH}$	Output HIGH voltage (TTL)	2.4	—	—	V	$I_{OH} = -1.0mA$
$V_{OL}$	Output LOW voltage (TTL)	—	—	0.5	V	$I_{OL} = +1.0mA$
$V_{IH}$	Input HIGH voltage (TTL)	2.0	—	5.5	V	

Parameters	Description	Min	Typ	Max	Units	Conditions
$V_{IL}$	Input LOW voltage (TTL)	0.0	—	0.8	V	
$I_{IH}$	Input HIGH current (TTL)	—	—	500	$\mu\text{A}$	$V_{IN} = 2.4\text{V}$
$I_{IL}$	Input LOW current (TTL)	—	—	-500	$\mu\text{A}$	$V_{IN} = 0.4\text{V}$
$V_{CC}$	Supply voltage	3.14	—	3.47	V	$3.3\text{V} \pm 5\%$
$P_D$	Power dissipation	—	1.2	1.7	W	Outputs open, $V_{CC} = V_{CC} \text{ max}$
$I_{CC}$	Supply current	—	350	490	mA	Outputs open, $V_{CC} = V_{CC} \text{ max}$

Figure 12: Parametric Measurement Information



### **Absolute Maximum Ratings <sup>(1)</sup>**

Power Supply Voltage ( $V_{CC}$ ).....	-0.5V to +3.8V
DC Input Voltage (differential inputs).....	-0.5V to $V_{CC} + 0.5V$
DC Input Voltage (TTL inputs).....	-0.5V to +5.5V
DC Output Voltage (TTL outputs).....	-0.5V to $V_{CC} + 0.5V$
Output Current (TTL outputs).....	+/-50mA
Output Current (differential outputs).....	+/-50mA
Case Temperature Under Bias.....	-55°C to +125°C

### **Recommended Operating Conditions**

Power Supply Voltage, ( $V_{CC}$ ).....	+3.3V±5%
Operating Temperature Range.....	0°C Ambient to +85°C Case Temperature

*NOTE: (1) CAUTION: Stresses listed under "Absolute Maximum Ratings" may be applied to devices one at a time without causing permanent damage. Functionality at or above the values listed is not implied. Exposure to these values for extended periods may affect device reliability.*

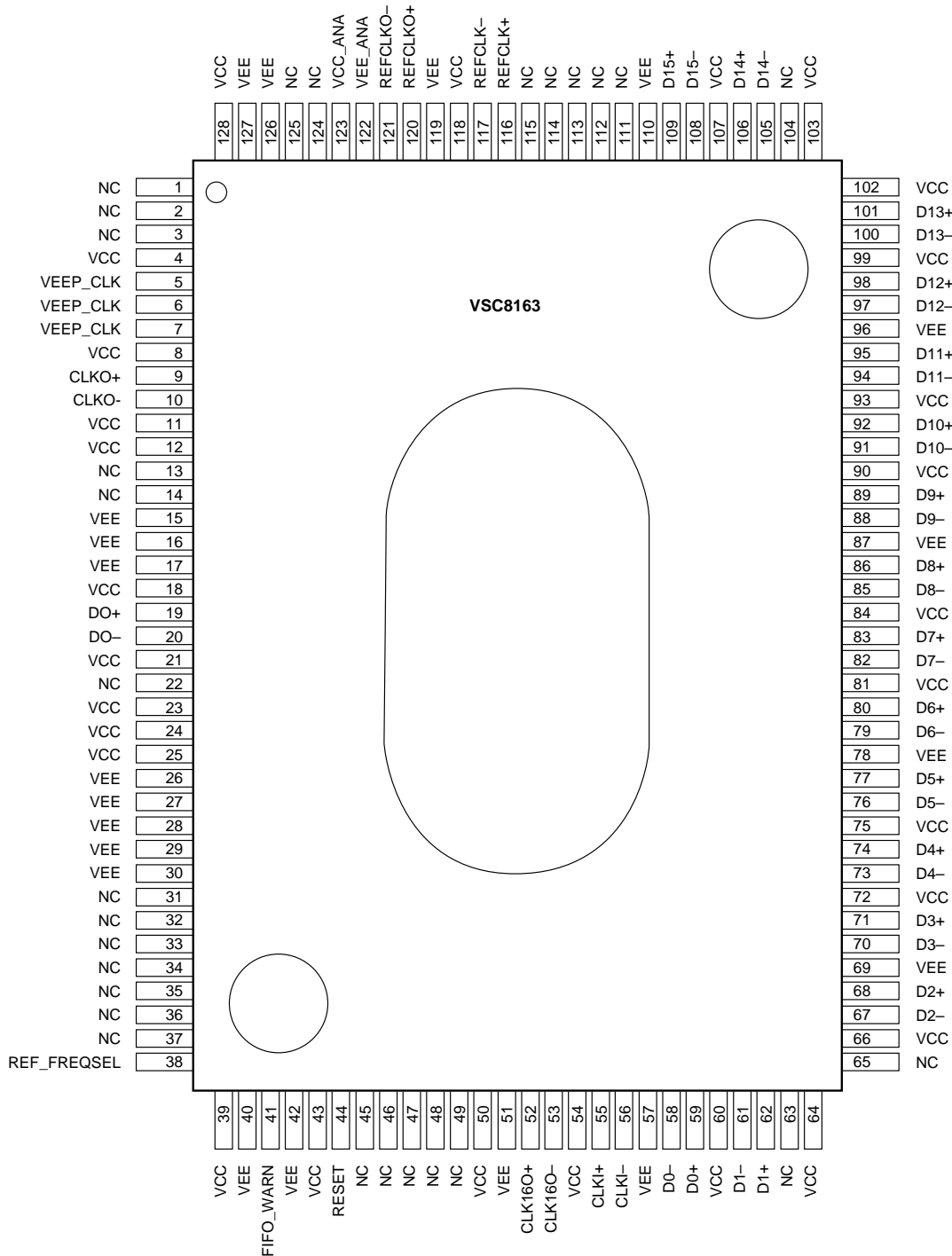
### **ESD Ratings**

Proper ESD procedures should be used when handling this product. The VSC8163 is rated to the following ESD voltages based on the human body model:

1. All pins are rated at or above 1500V.

## Package Pin Descriptions

Figure 13: Pin Diagram—128-Pin PQFP



## Package Pin Descriptions

Table 3: Package Pin Identification

Pin #	Name	I/O	Level	Description
1	NC	—	—	No connect, leave unconnected <sup>(1)</sup>
2	NC	—	—	No connect, leave unconnected <sup>(1)</sup>
3	NC	—	—	No connect, leave unconnected <sup>(1)</sup>
4	VCC	—	+3.3V typ.	Positive power supply
5	VEEP_CLK	—	GND typ.	High-speed clock V <sub>EE</sub> power supply (tie to V <sub>CC</sub> for power down)
6	VEEP_CLK	—	GND typ.	High-speed clock V <sub>EE</sub> power supply (tie to V <sub>CC</sub> for power down)
7	VEEP_CLK	—	GND typ.	High-speed clock V <sub>EE</sub> power supply (tie to V <sub>CC</sub> for power down)
8	VCC	—	+3.3V typ.	Positive power supply
9	CLKO+	O	HS	High-speed clock output, true
10	CLKO-	O	HS	High-speed clock output, complement
11	VCC	—	+3.3V typ.	Positive power supply
12	VCC	—	+3.3V typ.	Positive power supply
13	NC	—	—	No connect, leave unconnected <sup>(1)</sup>
14	NC	—	—	No connect, leave unconnected <sup>(1)</sup>
15	VEE	—	GND typ.	Negative power supply
16	VEE	—	GND typ.	Negative power supply
17	VEE	—	GND typ.	Negative power supply
18	VCC	—	+3.3V typ.	Positive power supply
19	DO+	O	HS	High-speed data output, true
20	DO-	O	HS	High-speed data output, complement
21	VCC	—	+3.3V typ.	Positive power supply
22	NC	—	—	No connect, leave unconnected <sup>(1)</sup>
23	VCC	—	+3.3V typ.	Positive power supply
24	VCC	—	+3.3V typ.	Positive power supply
25	VCC	—	+3.3V typ.	Positive power supply
26	VEE	—	GND typ.	Negative power supply
27	VEE	—	GND typ.	Negative power supply
28	VEE	—	GND typ.	Negative power supply
29	VEE	—	GND typ.	Negative power supply
30	VEE	—	GND typ.	Negative power supply
31	NC	—	—	No connect, leave unconnected <sup>(1)</sup>

Pin #	Name	I/O	Level	Description
32	NC	—	—	No connect, leave unconnected <sup>(1)</sup>
33	NC	—	—	No connect, leave unconnected <sup>(1)</sup>
34	NC	—	—	No connect, leave unconnected <sup>(1)</sup>
35	NC	—	—	No connect, leave unconnected <sup>(1)</sup>
36	NC	—	—	No connect, leave unconnected <sup>(1)</sup>
37	NC	—	—	No connect, leave unconnected <sup>(1)</sup>
38	REF_FREQSEL	I	TTL	Reference clock input select
39	VCC	—	+3.3V typ.	Positive power supply
40	VEE	—	GND typ.	Negative power supply
41	FIFO_WARN	O	TTL	FIFO overflow warning
42	VEE	—	GND typ.	Negative power supply
43	VCC	—	+3.3V typ.	Positive power supply
44	RESET	I	TTL	Reset to align FIFO Write and Read pointers
45	NC	—	—	No connect, leave unconnected <sup>(1)</sup>
46	NC	—	—	No connect, leave unconnected <sup>(1)</sup>
47	NC	—	—	No connect, leave unconnected <sup>(1)</sup>
48	NC	—	—	No connect, leave unconnected <sup>(1)</sup>
49	NC	—	—	No connect, leave unconnected <sup>(1)</sup>
50	VCC	—	+3.3V typ.	Positive power supply
51	VEE	—	GND typ.	Negative power supply
52	CLK160+	O	LVPECL	Low-speed clock output, true. A divide-by-16 version of the 2.48832GHz PLL.
53	CLK160-	O	LVPECL	Low-speed clock output, complement. A divide-by-16 version of the 2.48832GHz PLL.
54	VCC	—	+3.3V typ.	Positive power supply
55	CLKI+	I	LVPECL	Low-speed clock input for latching low-speed data, true
56	CLKI-	I	LVPECL	Low-speed clock input for latching low-speed data, complement
57	VEE	—	GND typ.	Negative power supply
58	D0-	I	LVPECL	Low-speed differential parallel data (MSB)
59	D0+	I	LVPECL	Low-speed differential parallel data (MSB)
60	VCC	—	+3.3V typ.	Positive power supply
61	D1-	I	LVPECL	Low-speed differential parallel data
62	D1+	I	LVPECL	Low-speed differential parallel data
63	NC	—	—	No connect, leave unconnected <sup>(1)</sup>

## Preliminary Data Sheet

### VSC8163

OC-48 16:1 SONET/SDH  
MUX with Clock Generator

Pin #	Name	I/O	Level	Description
64	VCC	—	+3.3V typ.	Positive power supply
65	NC	—	—	No connect, leave unconnected <sup>(1)</sup>
66	VCC	—	+3.3V typ.	Positive power supply
67	D2-	I	LVPECL	Low-speed differential parallel data
68	D2+	I	LVPECL	Low-speed differential parallel data
69	VEE	—	GND typ.	Negative power supply
70	D3-	I	LVPECL	Low-speed differential parallel data
71	D3+	I	LVPECL	Low-speed differential parallel data
72	VCC	—	+3.3V typ.	Positive power supply
73	D4-	I	LVPECL	Low-speed differential parallel data
74	D4+	I	LVPECL	Low-speed differential parallel data
75	VCC	—	+3.3V typ.	Positive power supply
76	D5-	I	LVPECL	Low-speed differential parallel data
77	D5+	I	LVPECL	Low-speed differential parallel data
78	VEE	—	GND typ.	Negative power supply
79	D6-	I	LVPECL	Low-speed differential parallel data
80	D6+	I	LVPECL	Low-speed differential parallel data
81	VCC	—	+3.3V typ.	Positive power supply
82	D7-	I	LVPECL	Low-speed differential parallel data
83	D7+	I	LVPECL	Low-speed differential parallel data
84	VCC	—	+3.3V typ.	Positive power supply
85	D8-	I	LVPECL	Low-speed differential parallel data
86	D8+	I	LVPECL	Low-speed differential parallel data
87	VEE	—	GND typ.	Negative power supply
88	D9-	I	LVPECL	Low-speed differential parallel data
89	D9+	I	LVPECL	Low-speed differential parallel data
90	VCC	—	+3.3V typ.	Positive power supply
91	D10-	I	LVPECL	Low-speed differential parallel data
92	D10+	I	LVPECL	Low-speed differential parallel data
93	VCC	—	+3.3V typ.	Positive power supply
94	D11-	I	LVPECL	Low-speed differential parallel data
95	D11+	I	LVPECL	Low-speed differential parallel data
96	VEE	—	GND typ.	Negative power supply
97	D12-	I	LVPECL	Low-speed differential parallel data

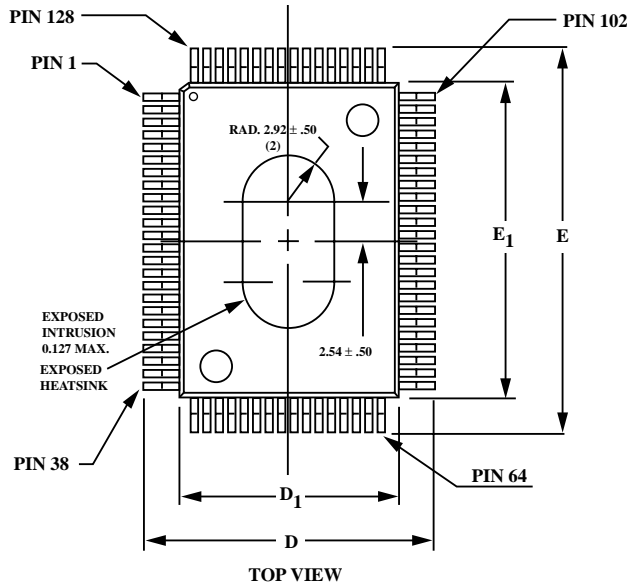
Pin #	Name	I/O	Level	Description
98	D12+	I	LVPECL	Low-speed differential parallel data
99	VCC	—	+3.3V typ.	Positive power supply
100	D13-	I	LVPECL	Low-speed differential parallel data
101	D13+	I	LVPECL	Low-speed differential parallel data
102	VCC	—	+3.3V typ.	Positive power supply
103	VCC	—	+3.3V typ.	Positive power supply
104	NC	—	—	No connect, leave unconnected <sup>(1)</sup>
105	D14-	I	LVPECL	Low-speed differential parallel data
106	D14+	I	LVPECL	Low-speed differential parallel data
107	VCC	—	+3.3V typ.	Positive power supply
108	D15-	I	LVPECL	Low-speed differential parallel data (LSB)
109	D15+	I	LVPECL	Low-speed differential parallel data (LSB)
110	VEE	—	GND typ.	Negative power supply
111	NC	—	—	No connect, leave unconnected <sup>(1)</sup>
112	NC	—	—	No connect, leave unconnected <sup>(1)</sup>
113	NC	—	—	No connect, leave unconnected <sup>(1)</sup>
114	NC	—	—	No connect, leave unconnected <sup>(1)</sup>
115	NC	—	—	No connect, leave unconnected <sup>(1)</sup>
116	REFCLK+	I	LVPECL	Reference clock input, true
117	REFCLK-	I	LVPECL	Reference clock input, complement
118	VCC	—	+3.3V typ.	Positive power supply
119	VEE	—	GND typ.	Negative power supply
120	REFCLKO+	O	LVPECL	Reference clock output, true
121	REFCLKO-	O	LVPECL	Reference clock output, complement
122	VEE_ANA	—	GND typ.	Negative power supply pins for analog parts of CMU
123	VCC_ANA	—	+3.3V typ.	Positive power supply pins for analog parts of CMU
124	NC	—	—	No connect, leave unconnected <sup>(1)</sup>
125	NC	—	—	No connect, leave unconnected <sup>(1)</sup>
126	VEE	—	GND typ.	Negative power supply
127	VEE	—	GND typ.	Negative power supply
128	VCC	—	+3.3V typ.	Positive power supply

NOTE: (1) No connect (NC) pins must be left unconnected, or floating. Connecting any of these pins to either the positive or negative power supply rails may cause improper operation or failure of the device or in extreme cases, cause permanent damage to the device.

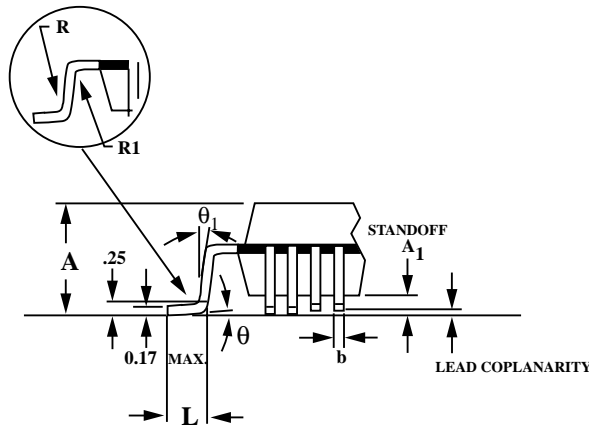
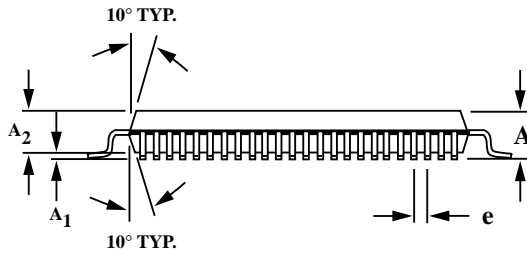


## Package Information

128-Pin PQFP Package Drawing



Key	mm	Tolerance
A	2.35	MAX
A1	0.25	MAX
A2	2.00	+ .10
D	17.20	±.20
D1	14.00	±.10
E	23.20	±.20
E1	20.00	±.10
L	.88	+ .15/- .10
e	.50	BASIC
b	.22	±.05
θ	0°-7°	
R	.30	TYP
R1	.20	TYP



- Notes: 1) Drawing is not to scale  
 2) All dimensions in mm  
 3) Package represented is also used for the 64, 80, & 100 PQFP packages. Pin count drawn does not reflect the 128 Package.

NOTES:

Package #: 101-322-5  
 Issue #: 2

## Thermal Considerations

This package has been enhanced with a copper heat slug to provide a low thermal resistance path from the die to the exposed surface of the heat spreader. The thermal resistance is shown in the following table

**Table 4: Thermal Resistance**

Symbol	Description	°C/W
$\theta_{JC}$	Thermal resistance from junction-to-case.	1.34
$\theta_{CA}$	Thermal resistance from case-to-ambient with no airflow, including conduction through the leads.	25.0

## Thermal Resistance with Airflow

Shown in the Table 5 is the thermal resistance with airflow. This thermal resistance value reflects all the thermal paths including through the leads in an environment where the leads are exposed. The temperature difference between the ambient airflow temperature and the case temperature should be the worst-case power of the device multiplied by the thermal resistance.

**Table 5: Thermal Resistance with Airflow**

Airflow	$\theta_{ca}$ (°C/W)
100 lfm	21
200 lfm	18
400 lfm	16
600 lfm	14.5

## Maximum Ambient Temperature without Heatsink

The worst case ambient temperature without use of a heatsink is given by the equation:

$$T_{A(MAX)} = T_{C(MAX)} - P_{(MAX)} \theta_{CA}$$

where:

- $\theta_{CA}$  Theta case-to-ambient at appropriate airflow
- $T_{A(MAX)}$  Ambient Air temperature
- $T_{C(MAX)}$  Case temperature (85°C for VSC8163)
- $P_{(MAX)}$  Power (1.7W for VSC8163)

## Preliminary Data Sheet

### VSC8163

OC-48 16:1 SONET/SDH  
MUX with Clock Generator

The results of this calculation are listed in Table 6:

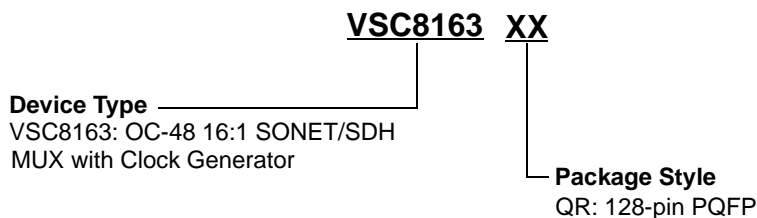
**Table 6: Maximum Ambient Air Temperature without Heatsink**

<i>Airflow</i>	<i>Max Ambient Temp( °C)</i>
None	43
100 lfpm	49
200 lfpm	54
400 lfpm	58
600 lfpm	60

Note that ambient air temperature varies throughout the system based on the positioning and magnitude of heat sources and the direction of air flow.

### Ordering Information

The order number for this product is formed by a combination of the device number, and package type.



### Notice

Vitesse Semiconductor Corporation (“Vitesse”) provides this document for informational purposes only. This document contains pre-production information about Vitesse products in their concept, development and/or testing phase. All information in this document, including descriptions of features, functions, performance, technical specifications and availability, is subject to change without notice at any time. Nothing contained in this document shall be construed as extending any warranty or promise, express or implied, that any Vitesse product will be available as described or will be suitable for or will accomplish any particular task.

Vitesse products are not intended for use in life support appliances, devices or systems. Use of a Vitesse product in such applications without written consent is prohibited.

OC-48 16:1 SONET/SDH  
MUX with Clock Generator

**Preliminary Data Sheet**  
**VSC8163**

