

Preliminary Data Sheet

VSC8169

OC-48 (FEC) 16:1 SONET/SDH
MUX with Clock Generator

Features

- 16:1 Multiplexer Up to 2.7Gb/s
- Targeted for SONET OC-48 / SDH STM-16 Applications
- Differential LVPECL Low-Speed Interface
- On-Chip PLL-Based Clock Generator
- 128-Pin 14x20mm PQFP Package
- Single +3.3V Supply

General Description

The VSC8169 is a 16:1 multiplexer with integrated clock generator for use in SONET/SDH systems operating at a standard 2.48832Gb/s data rate or a forward error correction (FEC) data rate up to 2.7Gb/s. The internal clock generator uses a Phase-Locked Loop (PLL) to multiply either a 77.76MHz (up to 84.38MHz-FEC) or a 155.52MHz (up to 168.75MHz -FEC) reference clock in order to provide the 2.48832GHz (up to 2.7GHz -FEC) clock for internal logic and output retiming. For use with the VSC9210 FEC Encoder/Decoder chipset running at 2.654208Gb/s, a reference clock of 82.944MHz (serial rate divided by 32) should be used. The 16-bit parallel interface incorporates an on-board FIFO eliminating loop timing design issues by providing a flexible parallel timing architecture. The device operates using a 3.3V power supply, and is packaged in a thermally-enhanced plastic package. The thermal performance of the 128-pin PQFP allows the use of the VSC8169 without a heat sink under most thermal conditions.

VSC8169 Block Diagram

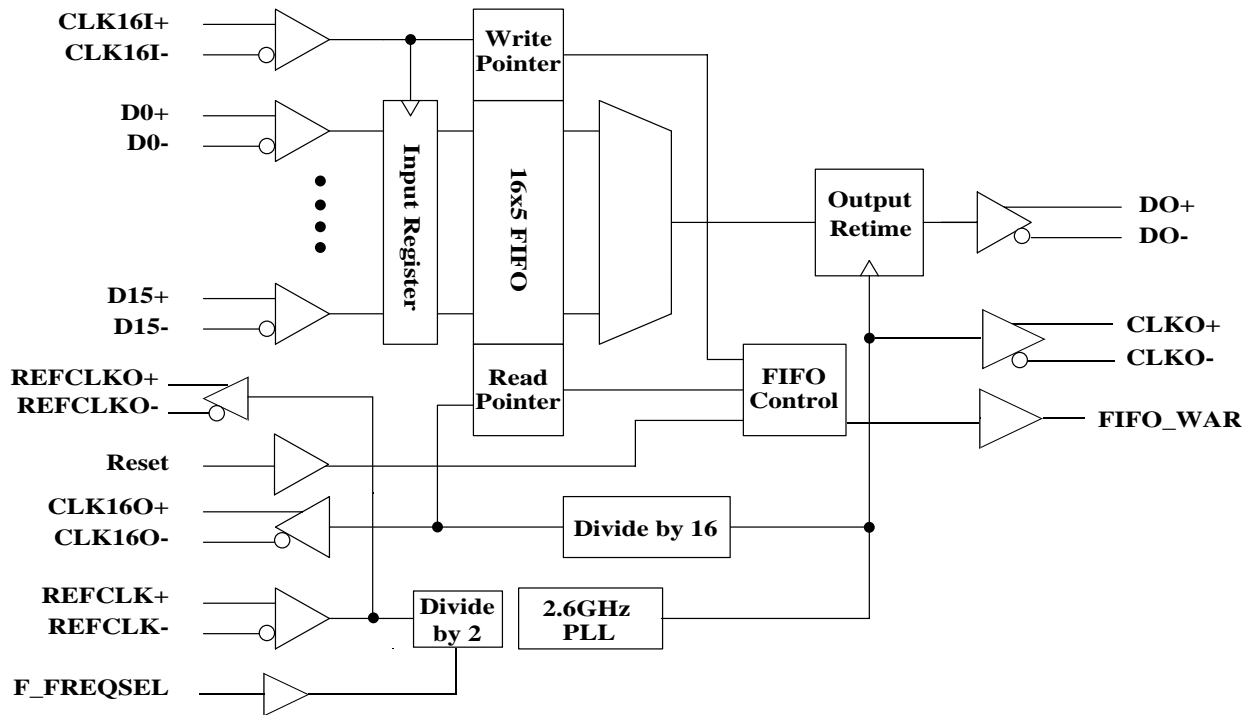

Functional Description

Low-Speed Interface

The Upstream Device should use the CLK16O as the timing source for its final output latch (see Figure 1). The Upstream Device should then generate a CLK16I that is phase aligned with the data. The VSC8169 will latch D[15:0] \pm on the rising edge of CLK16I+. The data must meet setup and hold times with respect to CLK16I (see Table 2). In addition to the CLK16O clock output, there also exists a utility REFCLKO output signal, which is a clock with the same rate as that presented at the REFCLK input.

A FIFO exists within the VSC8169 to eliminate difficult system loop timing issues. Once the PLL has locked to the reference clock, RESET must be held low for a minimum of five CLK16 cycles to initialize the FIFO, then RESET should be set high and held constant for continuous FIFO operation. For the transparent mode of operation (no FIFO), simply hold RESET at a constant low state (see Figure 2).

The use of a FIFO permits the system designer to tolerate an arbitrary amount of delay between CLK16O and CLK16I. Once RESET is asserted and the FIFO initialized, the delay between CLK16O and CLK16I can decrease or increase up to one period of the low-speed clock (6.4ns). Should this delay drift exceed one period, the write pointer and the read pointer could point to the same word in the FIFO, resulting in a loss of transmitted data (a FIFO overflow). In the event of a FIFO overflow, an active low FIFO_WARN signal is asserted (for a minimum of five CLK16I cycles) which can be used to initiate a reset signal from an external controller.

The CLK16O \pm output driver is a LVPECL output driver designed to drive a 50 Ω transmission line. The transmission line can be DC terminated with a split-end termination scheme (see Figure 3), or DC terminated by 50 Ω to V_{CC}-2V on each line (see Figure 4). At any time, the equivalent split-end termination technique can be substituted for the traditional 50 Ω to V_{CC}-2V on each line. AC-coupling can be achieved by a number of methods. Figure 5 illustrates an example AC-coupling method for the occasion when the downstream device provides the bias point for AC-coupling. If the downstream device were to have internal termination, the line to line 100 Ω resistor may not be necessary.

Figure 1: Low-Speed Systems Interface

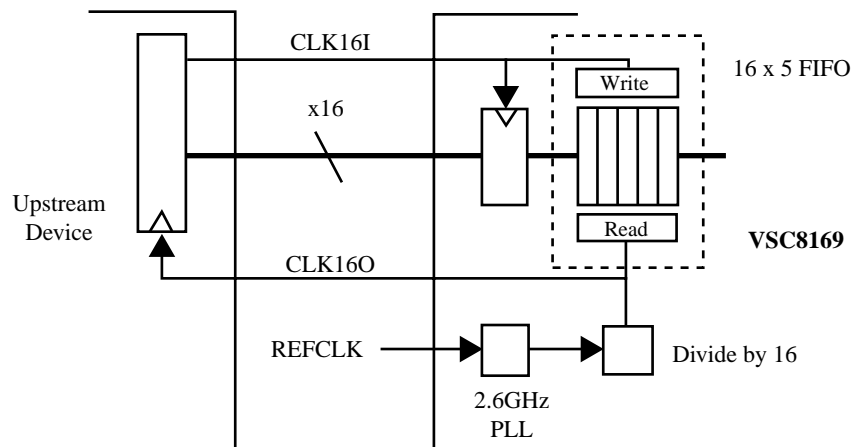
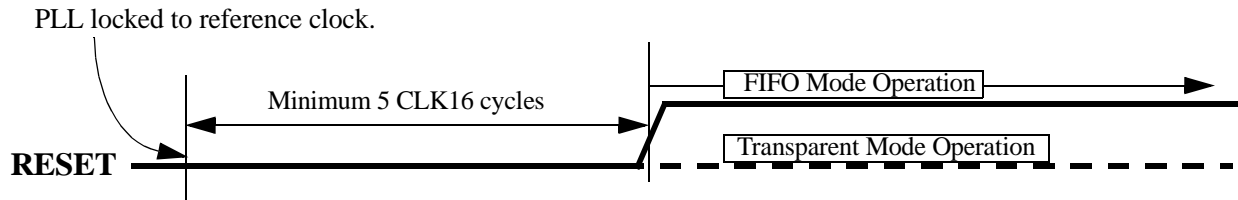

Figure 2: Enabling FIFO Operation



Holding RESET "low" for a minimum of 5 CLK16 cycles, then setting "high" enables FIFO operation.
Holding RESET constantly "low" bypasses the FIFO for transparent mode operation.

Figure 3: Split-End DC Termination of CLK16O+/-, REFCLKO+/-

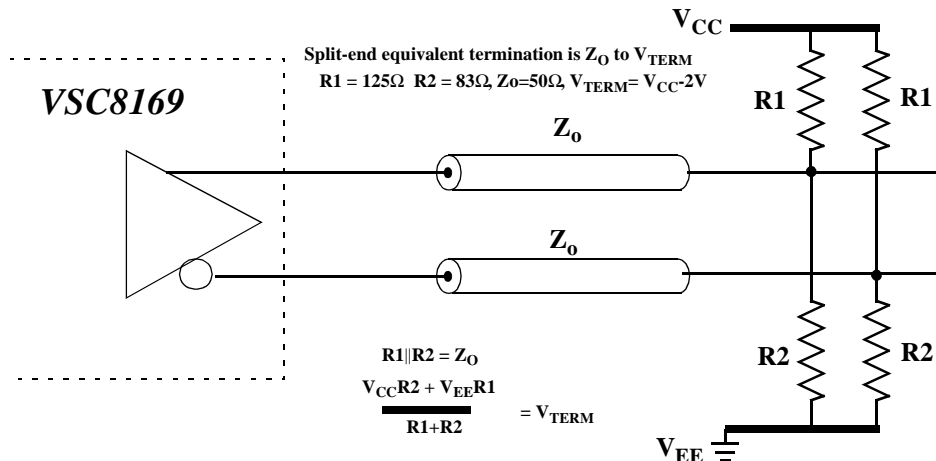

Figure 4: Traditional DC Termination of CLK16O+/-, REFCLKO+/-

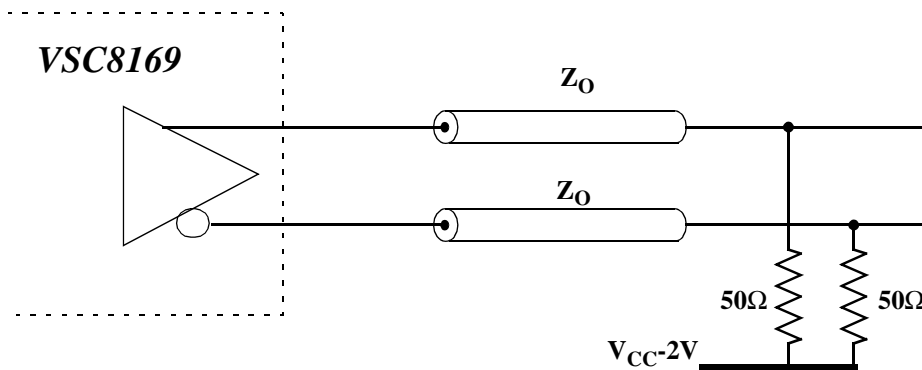
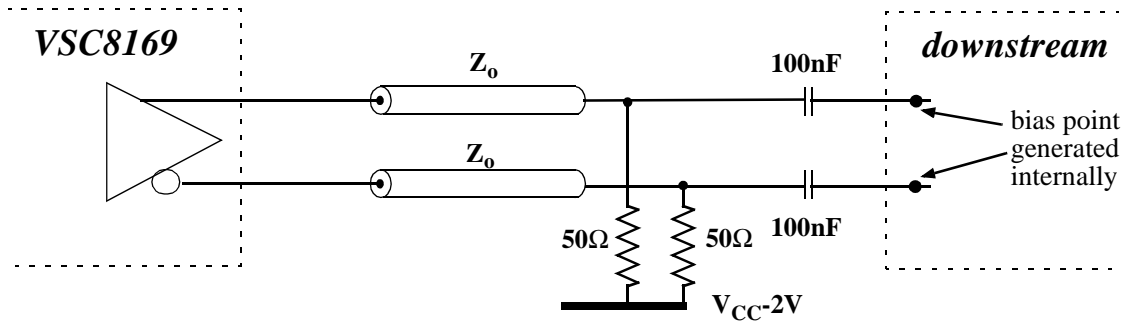

Figure 5: AC Termination of CLK16O+/-, REFCLKO+/-



High-Speed Data and Clock Output

The high-speed data and clock output drivers consist of a differential pair designed to drive a 50Ω transmission line. The transmission line should be terminated with a 100Ω resistor at the load between true and complement outputs (see Figure 6). Connection to a termination voltage is not required. The output driver is back terminated to 50Ω on-chip, providing a snubbing of any reflections. If used single-ended, the high-speed output driver must still be terminated differentially at the load with a 100Ω resistor between true and complement outputs. The high-speed clock output can be powered down for additional power savings. To power down the high-speed clock, tie the associated pins to V_{CC} (see Table 3, *Package Pin Identifications*, pins 5,6,7).

Figure 6: High-Speed Output Termination

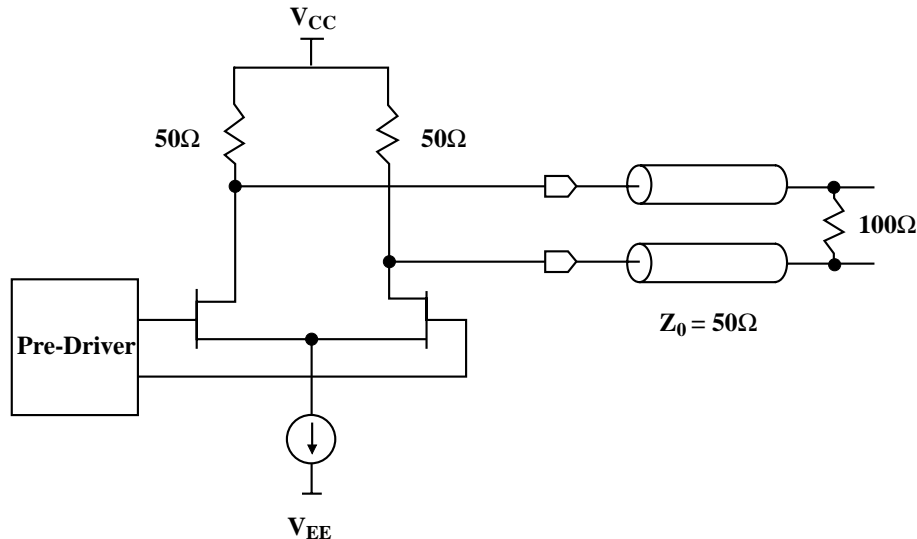

Clock Generator

An on-chip PLL generates the 2.48832GHz (or up to 2.7GHz for FEC) transmit clock from the externally provided REFCLK input. The on-chip PLL uses a low phase noise reactance-based Voltage Controlled Oscillator (VCO) with an on-chip loop filter. The loop bandwidth of the PLL is within the SONET specified limit of 2MHz.

Preliminary Data Sheet

VSC8169

OC-48 (FEC) 16:1 SONET/SDH
MUX with Clock Generator

The customer can select to provide either a 77.76MHz (up to 84.38MHz- FEC) reference (recommended), or the 2x of that reference, 155.52MHz (up to 168.75MHz-FEC). REF_FREQSEL is used to select the desired reference frequency. REF_FREQSEL = "0" designates REFCLK input as 77.76MHz (up to 84.38MHz-FEC), REF_FREQSEL = "1" designates REFCLK input as 155.52MHz (up to 168.75MHz - FEC) . For use with the VSC9210 FEC Encoder/Decoder chipset running at 2.654208Gb/s, REF_FREQSEL = "0" should be selected with the REFCLK input as 82.944MHz (serial rate divided by 32).

The REFCLK should be of high quality since noise on the REFCLK below the loop band width of the PLL will pass through the PLL and appear as jitter on the output. Preconditioning of the REFCLK signal with a VCXO may be required to avoid passing REFCLK noise with greater than 4ps RMS of jitter to the output. The VSC8169 will output the REFCLK noise in addition to the intrinsic jitter from the VSC8169 itself during such conditions.

Low-Speed Inputs

The incoming low-speed data and reference clock input are received by LVPECL inputs D[15:0] and REFCLK. Off-chip termination of these inputs is required. For AC-coupling, a bias voltage suitable for AC-coupling needs to be provided. See Figure 7 for external biasing resistor scheme.

In most situations these inputs will have high transition density and little DC offset. However, in cases where this does not hold, direct DC connection is possible. All serial data inputs have the same circuit topology, as shown in Figure 7. If the input signal is driven differentially and DC-coupled to the part, the mid-point of the input signal swing should be centered about this common mode reference voltage (V_{CM}) and not exceed the maximum allowable amplitude. For single-ended, DC-coupling operations, it is recommended that the user provides an external reference voltage. The external reference should have a nominal value equivalent to the common mode switch point of the DC-coupled signal, and can be connected to either side of the differential gate.

Figure 7: AC Termination of Low-Speed LVPECL REFCLK, D[15:0] Inputs

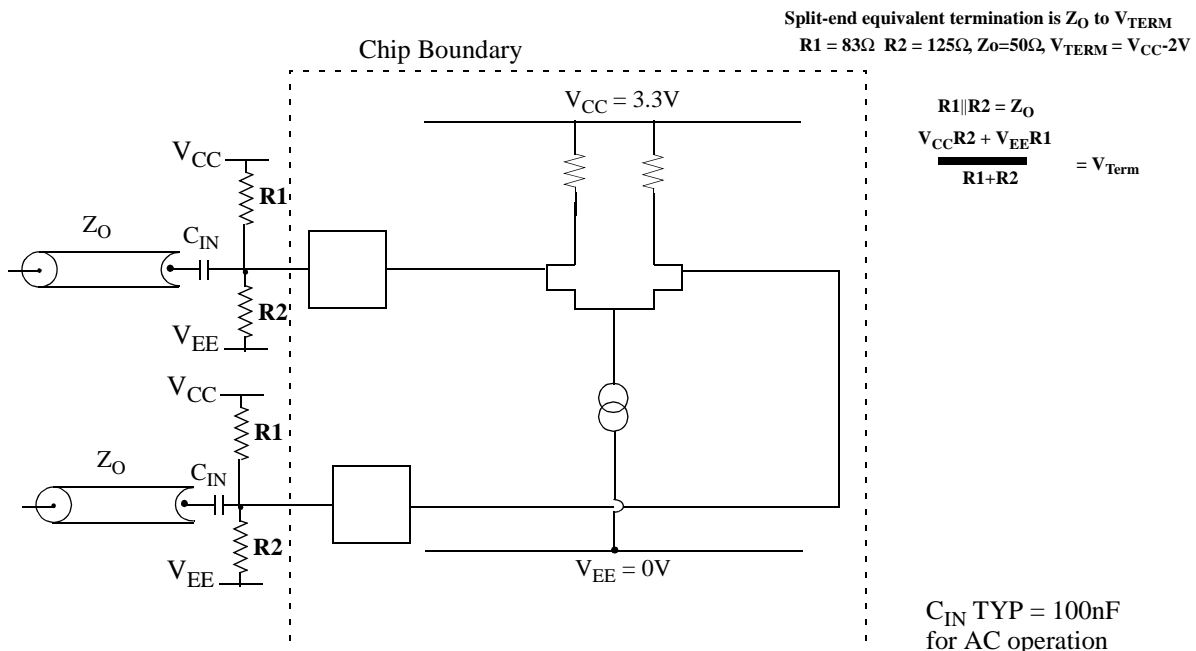

Supplies

The VSC8169 is specified as a LVPECL device with a single positive 3.3V supply. Should the user desire to use the device in an ECL environment with a negative 3.3V supply, then V_{CC} will be ground and V_{EE} will be -3.3V. If used with V_{EE} tied to -3.3V, the TTL control signals are still referenced to V_{EE} .

Decoupling of the power supplies is a critical element in maintaining the proper operation of the part. It is recommended that the V_{CC} power supply be decoupled using a 0.1 μ F and 0.01 μ F capacitor placed in parallel on each V_{CC} power supply pin as close to the package as possible. If room permits, a 0.001 μ F capacitor should also be placed in parallel with the 0.1 μ F and 0.01 μ F capacitors mentioned above. Recommended capacitors are low-inductance ceramic SMT X7R devices. For the 0.1 μ F capacitor, a 0603 package should be used. The 0.01 μ F and 0.001 μ F capacitors can be either 0603 or 0402 packages.

Extra care needs to be taken when decoupling the analog power supply pins (labeled V_{CCANA}). In order to maintain the optimal jitter and loop bandwidth characteristics of the PLL contained in the VSC8169, the analog power supply pins should be filtered from the main power supply with a 10 μ H C-L-C pi filter. If preferred, a ferrite bead may be used to provide the isolation. The 0.1 μ F and 0.01 μ F decoupling capacitors are still required and must be connected to the supply pins between the device and the C-L-C pi filter (or ferrite bead).

For low frequency decoupling, 47 μ F tantalum low inductance SMT caps are sprinkled over the board's main +3.3V power supply and placed close to the C-L-C pi filter.

If the device is being used in an ECL environment with a -3.3V supply, then all references to decoupling V_{CC} must be changed to V_{EE} , and all references to decoupling 3.3V must be changed to -3.3V.

Figure 8: PLL Power Supply Decoupling Scheme

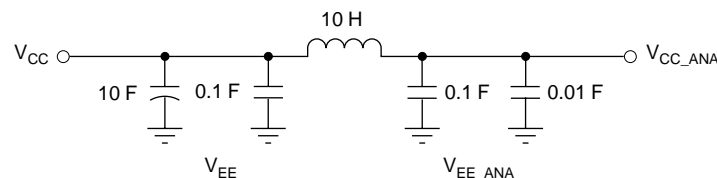

AC Characteristics

Figure 9: Parallel Input Data and Clock Timing Waveform

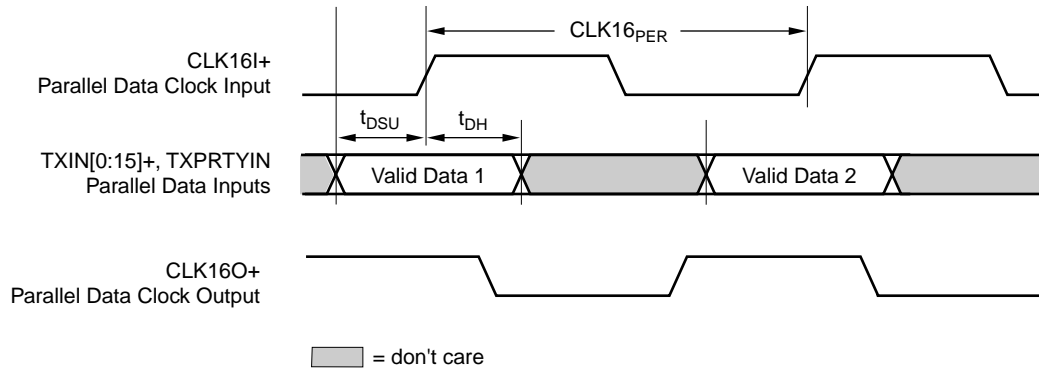
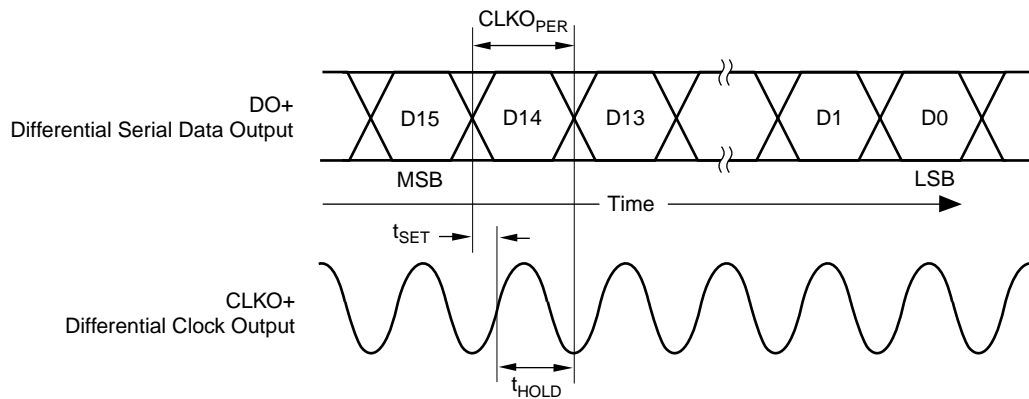

Figure 10: Serial Data and Clock Output Phase Timing Waveform



NOTE: Bit 15 (MSB) is received first, Bit 0 (LSB) is received last.

Table 1: AC Characteristics

Parameters	Description	Min	Typ	Max	Units	Conditions
t_{DSU}	Data setup time to the rising edge of CLK16I+	0.75	—	—	ns	
t_{DH}	Data hold time after the rising edge of CLK16+	1.0	—	—	ns	
t_{DOR}, t_{DOF}	DO \pm rise and fall time	—	—	120	ps	20% to 80% into 100 Ω load See Figure 6
t_{CLKR}, t_{CLKF}	CLK16O \pm rise and fall times	—	—	250	ps	See Figures 3 and 4
CLK16O $_D$	CLK16O \pm duty cycle	40	—	60	%	
CLKI $_D$	CLK16I \pm duty cycle	30	—	70	%	Assuming 10% distortion of CLKO
RCK $_D$	Reference Clock duty cycle	40	—	60	%	
CLKO $_D$	CLKO duty cycle	40	—	60	%	
CLKO $_{PER}$	CLKO period	—	401.9	—	ps	SONET-based 77.76MHz or 155.52MHz reference clock
CLK16O $_{PER}$	CLK16O period	—	6.4	—	ns	SONET-based 77.76MHz or 155.52MHz reference clock
t_{SET}	DO setup time with respect to rising CLKO edge	—	90	—	ps	Inverting CLKO will switch (approx) t_{SET} and t_{HOLD} values.
t_{HOLD}	DO hold time with respect to rising CLKO edge	—	310	—	ps	Inverting CLKO will switch (approx) t_{SET} and t_{HOLD} values.
Clock Multiplier Performance						
T_{DJ}	Output data jitter	—	—	4	ps	rms, tested to SONET specification (12kHz to 20MHz) with 2ps rms jitter on REFCLK.
T_{CJ}	Output clock jitter	—	—	4	ps	rms, tested to SONET specification (12kHz to 20MHz) with 2ps rms jitter on REFCLK.
Jitter $_{tol}$	Jitter tolerance	—	—	—	—	Exceeds SONET/SDH mask
	Tuning Range	-100		+100	ppm	

Figure 11: Differential and Single-Ended Input/Output Voltage Measurement

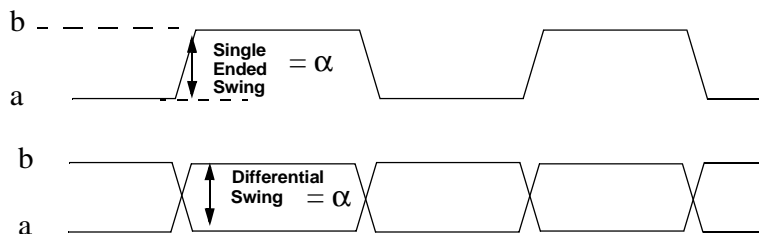

* Differential swing (α) is specified as $|b - a|$ (or $|a - b|$), as is the single-ended swing.
Differential swing is specified as equal in magnitude to single-ended swing.

Preliminary Data Sheet

VSC8169

OC-48 (FEC) 16:1 SONET/SDH
MUX with Clock Generator

Table 2: DC Characteristics (Over recommended operating conditions).

Parameters	Description	Min	Typ	Max	Units	Conditions
V _{OH(DO)}	Output HIGH voltage (DO)	V _{CC} -0.825	—	V _{CC}	V	See Figure 12
V _{OL(DO)}	Output LOW voltage (DO)	V _{CC} -1.30	—	V _{CC} -0.50	V	See Figure 12
ΔV _{OD(DO)}	Data output differential voltage (DO)	550	—	900	mV	100Ω termination between DO± at load
ΔV _{OCLK(CLKO)}	CLK output differential voltage (CLKO)	500	—	900	mV	100Ω termination between DO± at load
V _{CMO}	Output common-mode voltage	2.10	—	3.00	V	
R _{DO}	Back termination impedance	40	—	60	Ω	Guaranteed, but not tested
V _{OH}	Output HIGH voltage (CLK16O, REFCLKO±)	V _{CC} -1.020	—	V _{CC} -0.700	V	See Figure 12
V _{OL}	Output LOW voltage (CLK16O, REFCLKO±)	V _{CC} -2.000	—	V _{CC} -1.620	V	See Figure 12
V _{IH}	Input HIGH voltage (LVPECL)	V _{CC} -1.100	—	V _{CC} -0.700	V	
V _{IL}	Input LOW voltage (LVPECL)	V _{CC} -2.0	—	V _{CC} -1.540	V	
I _{IH}	Input HIGH current (LVPECL)	—	—	200	μA	V _{IN} =V _{IH} (max)
I _{IL}	Input LOW current (LVPECL)	-50	—	—	μA	V _{IN} =V _{IL} (min)
R _I	Input resistance (LVPECL)	10k	—	—	Ω	
ΔV _I	Input differential voltage (LVPECL)	200	—	—	mV	
V _{CMi}	Input common-mode voltage (LVPECL)	V _{CC} -1.5	—	V _{CC} -0.5	V	
V _{OH}	Output HIGH voltage (TTL)	2.4	—	—	V	I _{OH} = -1.0 mA
V _{OL}	Output LOW voltage (TTL)	—	—	0.5	V	I _{OL} = +1.0 mA
V _{IH}	Input HIGH voltage (TTL)	2.0	—	5.5	V	
V _{IL}	Input LOW voltage (TTL)	0.0	—	0.8	V	
I _{IH}	Input HIGH Current (TTL)	—	—	500	μA	V _{IN} = 2.4V
I _{IL}	Input LOW Current (TTL)	—	—	-500	μA	V _{IN} = 0.4V
V _{CC}	Supply voltage	3.14	—	3.47	V	3.3V± 5%
P _D	Power dissipation	—	1.2	1.7	W	Outputs open, V _{CC} = V _{CC} max
I _{CC}	Supply current	—	350	490	mA	Outputs open, V _{CC} = V _{CC} max

Figure 12: Parametric Measurement Information

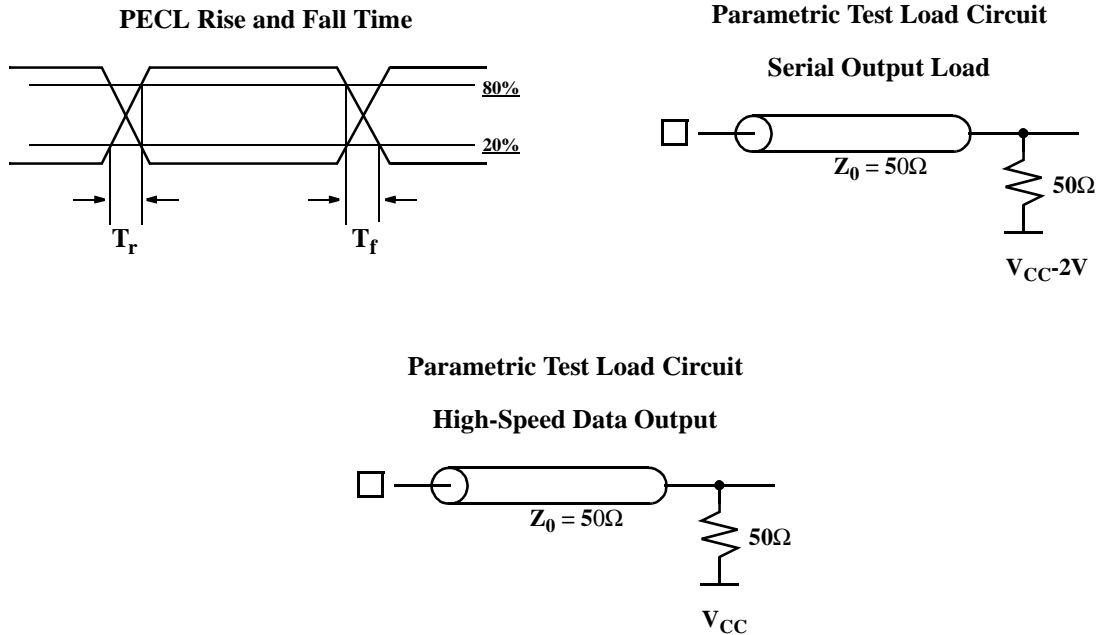

Absolute Maximum Ratings ⁽¹⁾

Power Supply Voltage, (V_{CC}).....	-0.5V to +3.8V
DC Input Voltage (Differential inputs).....	-0.5V to $V_{CC} + 0.5V$
DC Input Voltage (TTL inputs).....	-0.5V to +5.5V
DC Output Voltage (TTL Outputs).....	-0.5V to $V_{CC} + 0.5V$
Output Current (TTL Outputs).....	$\pm 50mA$
Output Current (Differential Outputs).....	$\pm 50mA$
Case Temperature Under Bias.....	$-55^{\circ}C$ to $+125^{\circ}C$

NOTE: (1) CAUTION: Stresses listed under "Absolute Maximum Ratings" may be applied to devices one at a time without causing permanent damage. Functionality at or above the values listed is not implied. Exposure to these values for extended periods may affect device reliability.

Recommended Operating Conditions

Power Supply Voltage, (V_{CC}).....	$+3.3V \pm 5\%$
Operating Temperature Range.....	$0^{\circ}C$ Ambient to $+85^{\circ}C$ Case Temperature

ESD Ratings

Proper ESD procedures should be used when handling this product. The VSC8169 is rated to the following ESD voltages based on the human body model:

1. All pins are rated at or above 1500V.

Package Pin Descriptions

Figure 13: Pin Diagram

Top View—128-Pin PQFP

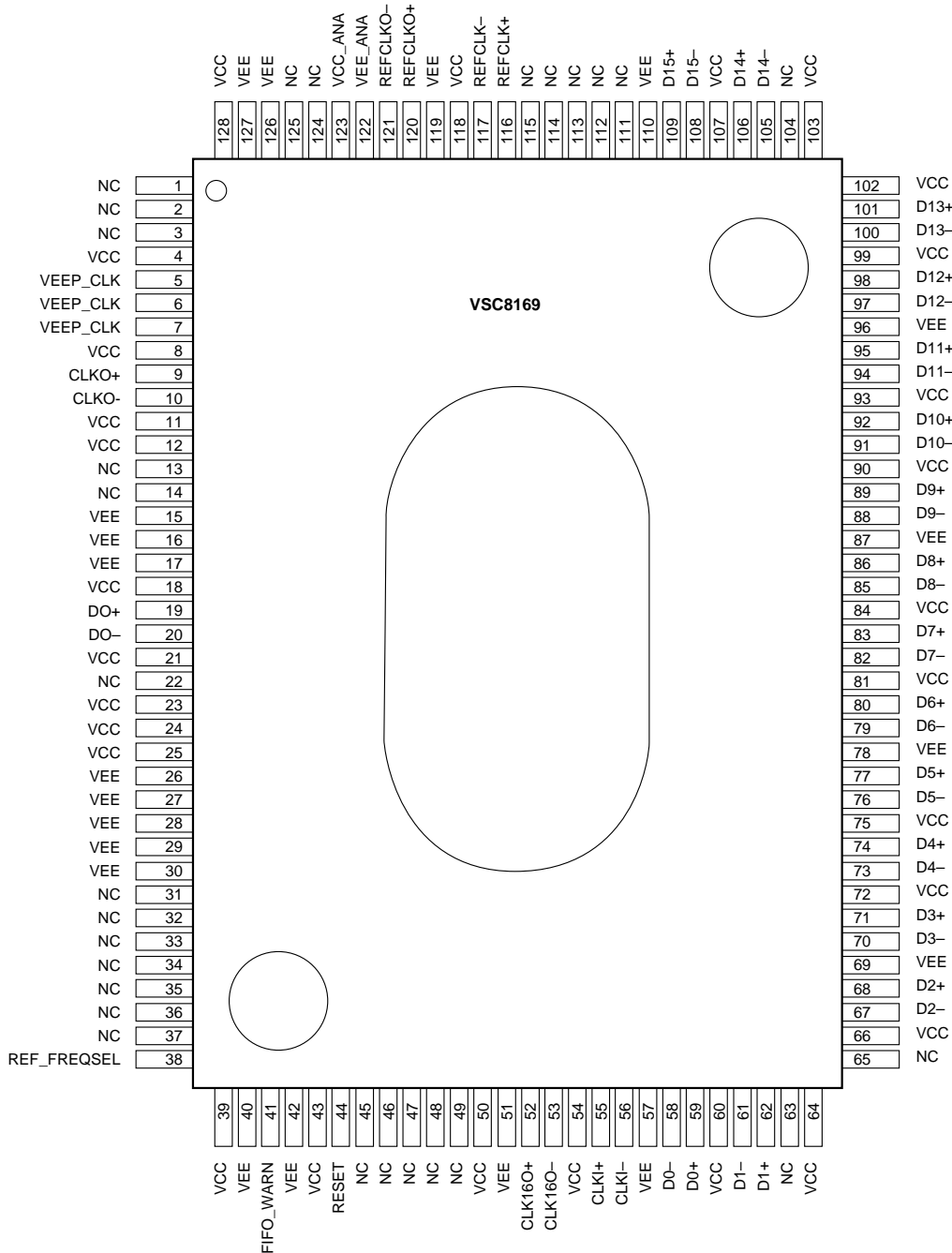

Table 3: Package Pin Identification

Pin #	Name	I/O	Level	Description
1	NC	—	—	No connect, leave unconnected ⁽¹⁾
2	NC	—	—	No connect, leave unconnected ⁽¹⁾
3	NC	—	—	No connect, leave unconnected ⁽¹⁾
4	VCC	—	+3.3V	Positive power supply
5	VEEP_CLK	—	GND	High-speed clock V _{EE} power supply (tie to V _{CC} for power down)
6	VEEP_CLK	—	GND	High-speed clock V _{EE} power supply (tie to V _{CC} for power down)
7	VEEP_CLK	—	GND	High-speed clock V _{EE} power supply (tie to V _{CC} for power down)
8	VCC	—	+3.3V	Positive power supply
9	CLKO+	O	HS	High-speed clock output, true
10	CLKO-	O	HS	High-speed clock output, complement
11	VCC	—	+3.3V	Positive power supply
12	VCC	—	+3.3V	Positive power supply
13	NC	—	—	No connect, leave unconnected ⁽¹⁾
14	NC	—	—	No connect, leave unconnected ⁽¹⁾
15	VEE	—	GND	Negative power supply
16	VEE	—	GND	Negative power supply
17	VEE	—	GND	Negative power supply
18	VCC	—	+3.3V	Positive power supply
19	DO+	O	HS	High-speed data output, true
20	DO-	O	HS	High-speed data output, complement
21	VCC	—	+3.3V	Positive power supply
22	NC	—	—	No connect, leave unconnected ⁽¹⁾
23	VCC	—	+3.3V	Positive power supply
24	VCC	—	+3.3V	Positive power supply
25	VCC	—	+3.3V	Positive power supply
26	VEE	—	GND	Negative power supply
27	VEE	—	GND	Negative power supply
28	VEE	—	GND	Negative power supply
29	VEE	—	GND	Negative power supply
30	VEE	—	GND	Negative power supply
31	NC	—	—	No connect, leave unconnected ⁽¹⁾
32	NC	—	—	No connect, leave unconnected ⁽¹⁾
33	NC	—	—	No connect, leave unconnected ⁽¹⁾
34	NC	—	—	No connect, leave unconnected ⁽¹⁾

Preliminary Data Sheet

VSC8169

OC-48 (FEC) 16:1 SONET/SDH
MUX with Clock Generator

Pin #	Name	I/O	Level	Description
35	NC	—	—	No connect, leave unconnected ⁽¹⁾
36	NC	—	—	No connect, leave unconnected ⁽¹⁾
37	NC	—	—	No connect, leave unconnected ⁽¹⁾
38	REF_FREQSEL	I	TTL	Reference clock input select
39	VCC	—	+3.3V	Positive power supply
40	VEE	—	GND	Negative power supply
41	FIFO_WARN	O	TTL	FIFO overflow warning
42	VEE	—	GND	Negative power supply
43	VCC	—	+3.3V	Positive power supply
44	RESET	I	TTL	Reset to align FIFO Write and Read pointers
45	NC	—	—	No connect, leave unconnected ⁽¹⁾
46	NC	—	—	No connect, leave unconnected ⁽¹⁾
47	NC	—	—	No connect, leave unconnected ⁽¹⁾
48	NC	—	—	No connect, leave unconnected ⁽¹⁾
49	NC	—	—	No connect, leave unconnected ⁽¹⁾
50	VCC	—	+3.3V	Positive power supply
51	VEE	—	GND	Negative power supply
52	CLK16O+	O	LVPECL	Low-speed clock output, true. A divide-by-16 version of the PLL clock.
53	CLK16O-	O	LVPECL	Low-speed clock output, complement. A divide-by-16 version of the PLL clock.
54	VCC	—	+3.3V	Positive power supply
55	CLKI+	I	LVPECL	Low-speed clock input for latching low-speed data, true
56	CLKI-	I	LVPECL	Low-speed clock input for latching low-speed data, complement
57	VEE	—	GND	Negative power supply
58	D0-	I	LVPECL	Low-speed differential parallel data
59	D0+	I	LVPECL	Low-speed differential parallel data
60	VCC	—	+3.3V	Positive power supply
61	D1-	I	LVPECL	Low-speed differential parallel data
62	D1+	I	LVPECL	Low-speed differential parallel data
63	NC	—	—	No connect, leave unconnected ⁽¹⁾
64	VCC	—	+3.3V	Positive power supply
65	NC	—	—	No connect, leave unconnected ⁽¹⁾
66	VCC	—	+3.3V	Positive power supply
67	D2-	I	LVPECL	Low-speed differential parallel data
68	D2+	I	LVPECL	Low-speed differential parallel data

Pin #	Name	I/O	Level	Description
69	VEE	—	GND	Negative power supply
70	D3-	I	LVPECL	Low-speed differential parallel data
71	D3+	I	LVPECL	Low-speed differential parallel data
72	VCC	—	+3.3V	Positive power supply
73	D4-	I	LVPECL	Low-speed differential parallel data
74	D4+	I	LVPECL	Low-speed differential parallel data
75	VCC	—	+3.3V	Positive power supply
76	D5-	I	LVPECL	Low-speed differential parallel data
77	D5+	I	LVPECL	Low-speed differential parallel data
78	VEE	—	GND	Negative power supply
79	D6-	I	LVPECL	Low-speed differential parallel data
80	D6+	I	LVPECL	Low-speed differential parallel data
81	VCC	—	+3.3V	Positive power supply
82	D7-	I	LVPECL	Low-speed differential parallel data
83	D7+	I	LVPECL	Low-speed differential parallel data
84	VCC	—	+3.3V	Positive power supply
85	D8-	I	LVPECL	Low-speed differential parallel data
86	D8+	I	LVPECL	Low-speed differential parallel data
87	VEE	—	GND	Negative power supply
88	D9-	I	LVPECL	Low-speed differential parallel data
89	D9+	I	LVPECL	Low-speed differential parallel data
90	VCC	—	+3.3V	Positive power supply
91	D10-	I	LVPECL	Low-speed differential parallel data
92	D10+	I	LVPECL	Low-speed differential parallel data
93	VCC	—	+3.3V	Positive power supply
94	D11-	I	LVPECL	Low-speed differential parallel data
95	D11+	I	LVPECL	Low-speed differential parallel data
96	VEE	—	GND	Negative power supply
97	D12-	I	LVPECL	Low-speed differential parallel data
98	D12+	I	LVPECL	Low-speed differential parallel data
99	VCC	—	+3.3V	Positive power supply
100	D13-	I	LVPECL	Low-speed differential parallel data
101	D13+	I	LVPECL	Low-speed differential parallel data
102	VCC	—	+3.3V	Positive power supply
103	VCC	—	+3.3V	Positive power supply

Preliminary Data Sheet

VSC8169

OC-48 (FEC) 16:1 SONET/SDH
MUX with Clock Generator

Pin #	Name	I/O	Level	Description
104	NC	—	—	No connect, leave unconnected ⁽¹⁾
105	D14-	I	LVPECL	Low-speed differential parallel data
106	D14+	I	LVPECL	Low-speed differential parallel data
107	VCC	—	+3.3V	Positive power supply
108	D15-	I	LVPECL	Low-speed differential parallel data
109	D15+	I	LVPECL	Low-speed differential parallel data
110	VEE	—	GND	Negative power supply
111	NC	—	—	No connect, leave unconnected ⁽¹⁾
112	NC	—	—	No connect, leave unconnected ⁽¹⁾
113	NC	—	—	No connect, leave unconnected ⁽¹⁾
114	NC	—	—	No connect, leave unconnected ⁽¹⁾
115	NC	—	—	No connect, leave unconnected ⁽¹⁾
116	REFCLK+	I	LVPECL	Reference clock input, true
117	REFCLK-	I	LVPECL	Reference clock input, complement
118	VCC	—	+3.3V	Positive power supply
119	VEE	—	GND	Negative power supply
120	REFCLKO+	O	LVPECL	Reference clock output, true
121	REFCLKO-	O	LVPECL	Reference clock output, complement
122	VEE_ANA	—	GND	Negative power supply pins for analog parts of CMU
123	VCC_ANA	—	+3.3V	Positive power supply pins for analog parts of CMU
124	NC	—	—	No connect, leave unconnected ⁽¹⁾
125	NC	—	—	No connect, leave unconnected ⁽¹⁾
126	VEE	—	GND	Negative power supply
127	VEE	—	GND	Negative power supply
128	VCC	—	+3.3V	Positive power supply

NOTE: (1) No connect (NC) pins must be left unconnected, or floating. Connecting any of these pins to either the positive or negative power supply rails may cause improper operation or failure of the device; or in extreme cases, cause permanent damage to the device.

Package Information

128-Pin PQFP Package Drawing

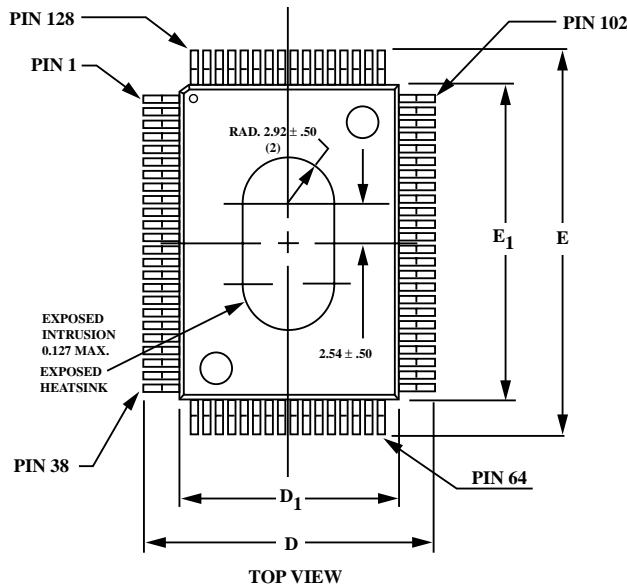

Key	mm	Tolerance
A	2.35	MAX
A1	0.25	MAX
A2	2.00	+ .10
D	17.20	±.20
D1	14.00	±.10
E	23.20	±.20
E1	20.00	±.10
L	.88	+ .15/- .10
e	.50	BASIC
b	.22	±.05
θ	0°-7°	
R	.30	TYP
R1	.20	TYP

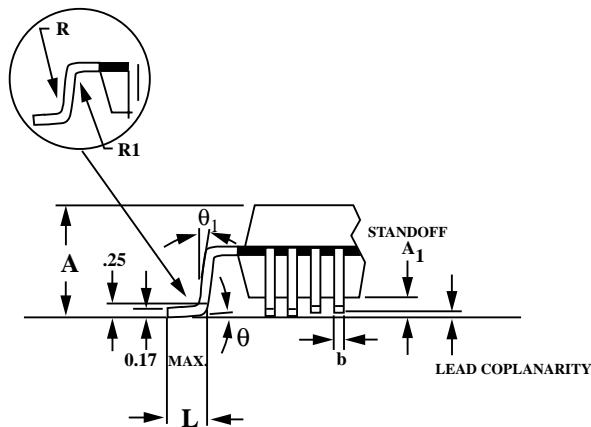
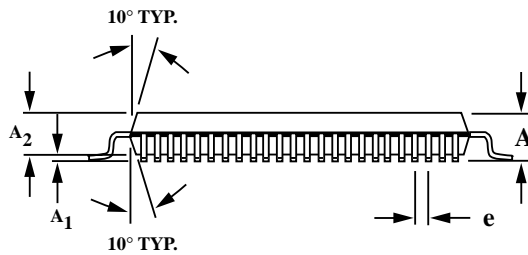

- Notes: 1) Drawing is not to scale
2) All dimensions in mm
3) Package represented is also used for the 64, 80, & 100 PQFP packages. Pin count drawn does not reflect the 128 Package.

NOTES:

Package #: 101-322-5
Issue #: 2

Thermal Considerations

This package has been enhanced with a copper heat slug to provide a low thermal resistance path from the die to the exposed surface of the heat spreader. The thermal resistance is shown in the Table 4.

Table 4: Thermal Resistance

Symbol	Description	°C/W
θ_{JC}	Thermal resistance from junction-to-case.	1.34
θ_{CA}	Thermal resistance from case-to-ambient with no airflow, including conduction through the leads.	25.0

Thermal Resistance with Airflow

Shown in the Table 5 is the thermal resistance with airflow. This thermal resistance value reflects all the thermal paths including through the leads in an environment where the leads are exposed. The temperature difference between the ambient airflow temperature and the case temperature should be the worst case power of the device multiplied by the thermal resistance.

Table 5: Thermal Resistance with Airflow

Airflow	θ_{ca} (°C/W)
100 lfpm	21
200 lfpm	18
400 lfpm	16
600 lfpm	14.5

Maximum Ambient Temperature without Heatsink

The worst-case ambient temperature without use of a heatsink is given by the equation:

$$T_{A(MAX)} = T_{C(MAX)} - P_{(MAX)} \theta_{CA}$$

where:

- θ_{CA} Theta case-to-ambient at appropriate airflow
- $T_{A(MAX)}$ Ambient air temperature
- $T_{C(MAX)}$ Case temperature (85°C for VSC8169)
- $P_{(MAX)}$ Power (1.7 W for VSC8169)

The results of this calculation are listed below:

Table 6: Maximum Ambient Air Temperature without Heatsink

<i>Airflow</i>	<i>Max Ambient Temperature (°C)</i>
None	43
100 lfpm	49
200 lfpm	54
400 lfpm	58
600 lfpm	60

Note that ambient air temperature varies throughout the system based on the positioning and magnitude of heat sources and the direction of air flow.

Ordering Information

The order number for this product is formed by a combination of the device number, and package type.

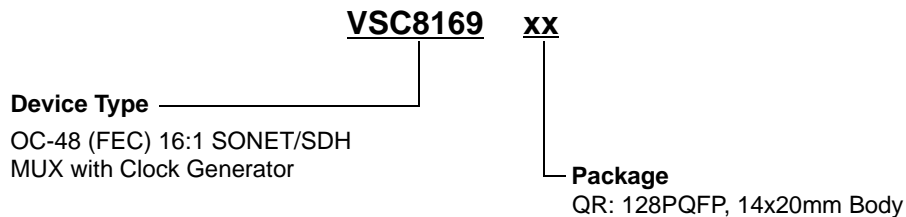

Notice

Vitesse Semiconductor Corporation (“Vitesse”) provides this document for informational purposes only. This document contains pre-production information about Vitesse products in their concept, development and/or testing phase. All information in this document, including descriptions of features, functions, performance, technical specifications and availability, is subject to change without notice at any time. Nothing contained in this document shall be construed as extending any warranty or promise, express or implied, that any Vitesse product will be available as described or will be suitable for or will accomplish any particular task.

Vitesse products are not intended for use in life support appliances, devices or systems. Use of a Vitesse product in such applications without written consent is prohibited.