

HPI - 6FFR4

The HPI - 6FFR4 is a high - output, high - speed silicon PIN photodiode mounted in a sidelooking package. The photodiode is small size, low profile and easy mounting.

FEATURES

- High - output power
- High - speed response
- Wide angular response
- Low - cost
- Sidelooking plastic package

APPLICATIONS

- Remote control sensors
- Optical switches
- Photocoupler

DIMENSIONS

(Unit : mm)

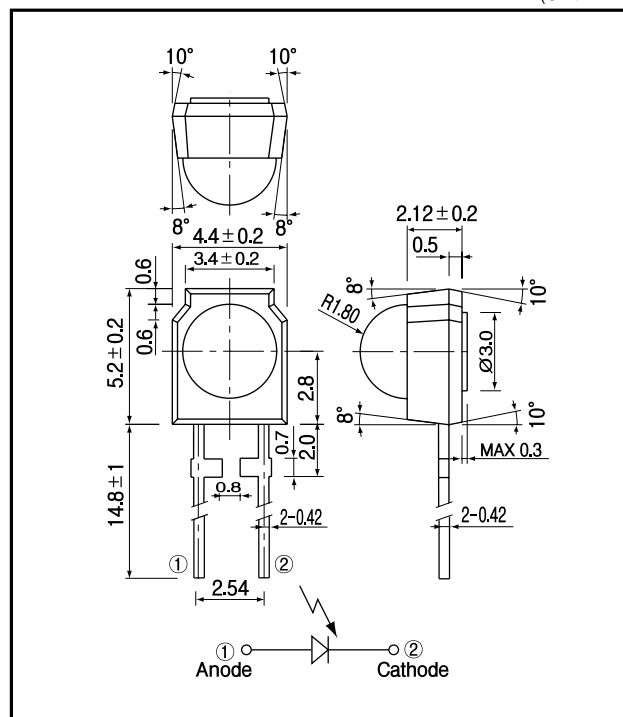

MAXIMUM RATINGS

(Ta=25)

Item	Symbol	Rating	Unit
Reverse voltage	V_R	35	V
Operating temp.	Topr.	- 30 + 70	
Storage temp.	Tstg.	- 40 + 80	
Soldering temp.*1	Tsol.	260	

*1.For MAX.5 seconds at the position of 2 mm from the package

ELECTRO-OPTICAL CHARACTERISTICS

(Ta=25)

Item	Symbol	Conditions	Min.	Typ.	Max.	Unit.
Open circuit voltage	V_{oc}	$E_v = 1,000lx^2$		0.38		V
Short circuit current	I_{sc}			20		μA
Curve factor	C.F.	$V_R = 10V$			10	nA
Dark current	I_d		0.55			-
Capacitance	C_t	$V = 0V, f = 1MHz$		16		pF
Temperature coefficient of V_{oc}	t			- 2.2		mV/
Temperature coefficient of I_{sc}	t			0.18		%/
Spectral sensitivity				880 1050		nm
Peak wavelength	p			1,000		nm
Half angle				± 35		deg

*2.Color temp.=2856K standard Tungsten lamp

PIN Photodiode

HPI - 6FFR4

Light current Vs. Forward voltage

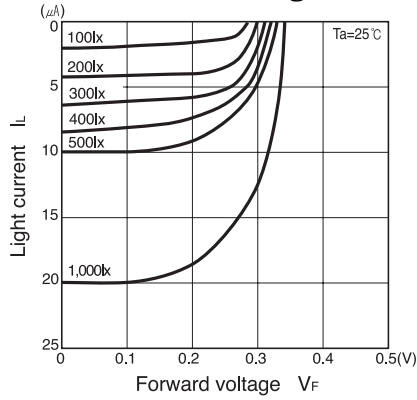

Short circuit current Vs. Illuminance

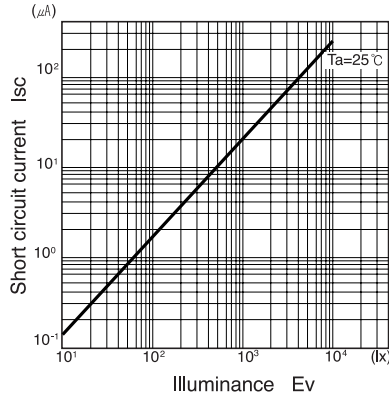

Dark current Vs. Ambient temperature

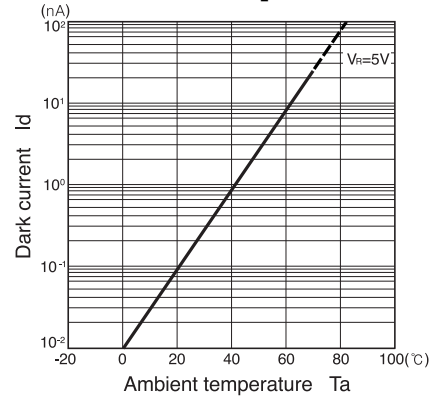

Relative sensitivity Vs. Wavelength

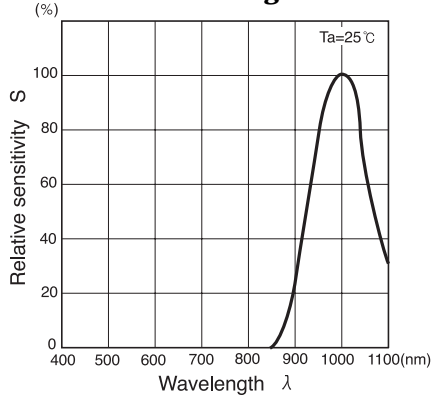

Dark current Vs. Reverse voltage

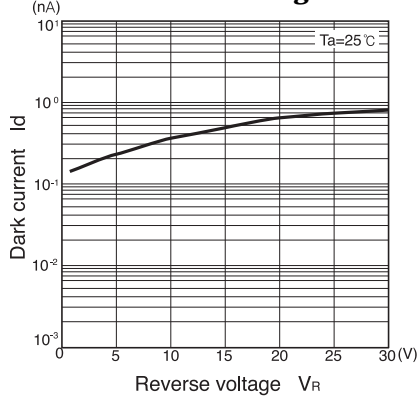

Radiant Pattern

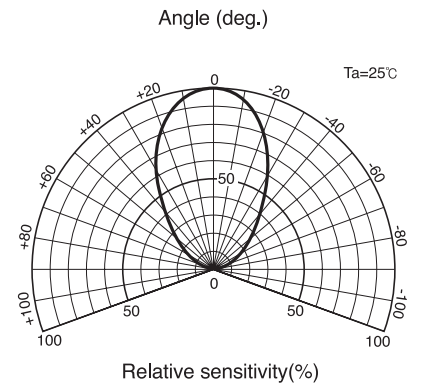

Capacitance between terminals Vs. Reverse voltage

